



CATALOGO 48-2020

www.trem.net



I PREZZI ALL'INTERNO SONO CONSIGLIATI AL PUBBLICO IVA ESCLUSA



Una vita di lavoro e successi navigando verso i 50 anni ...

Proprio cinquant'anni fa, Franco Marzaduri decise di fondare Trecciatura Emiliana srl (TR.EM. srl), dedicandosi alla produzione di corda elastica, inizialmente per coprire le ruote posteriori delle biciclette da donna, un articolo tanto inusuale quanto storico, successivamente per fermare i bagagli sul tetto delle auto.

Tuttavia, tutti sappiamo che le mode cambiano e la tecnologia si deve adeguare ai nuovi tempi, così TR.EM. iniziò a produrre corda per vela, traino sci e articoli per la sicurezza in mare, espandendo successivamente la produzione allo stampaggio plastica (doccette, sportelli, luci di navigazione, ecc...), lavorazione legno (scalette e passerelle), lavorazione alluminio e acciaio (mezzi marinai, pagaie, porta zattera, supporti motore, ecc...).

Grazie a questo spirito imprenditoriale, la storica Azienda di Osteria Grande è riuscita ad esportare i propri prodotti in tutto il mondo; non sarà difficile trovarsi a bordo di un traghetto nella baia di Sydney, piuttosto che su di un catamarano ai Caraibi, con un mezzo marinaio TR.EM. in mano!

TR.EM. è la mia vita. La mia famiglia. La mia storia. Una storia fatta di sogni, di duro lavoro, una storia di sacrifici e di sfide, una storia di gioie e di orgoglio. Con la certezza di passare almeno altri 50 anni in mare con voi, desidero ringraziare calorosamente tutti i nostri clienti, vecchi e nuovi, per la fiducia dimostrata in tutti questi anni.

Franco Marzaduri
President

A life of work and success

50 years ago I decided to found Trecciatura Emiliana srl (TR.EM. Srl) focusing on the production of shock cords used to cover the rear wheels of women's bicycles. That article was very unusual but now it belongs to the history of our Company. Later shock cords have been used to lock luggage on car roofs.

However everybody knows that habits change and that technology needs to be adapted to the new times, so TR.EM. started to produce sailing rope, ski rope and safety items for boating, expanding the production range with the plastic molding (showers, hatches, navigation lights), woodworking (ladders and gangways), aluminium and stainless steel working (boat hooks, oars, liferaft frames, motor brackets).

Thanks to this entrepreneurial spirit, in these 50 years our Company has managed to export its products all over the world; I think it will not be difficult to find a boat hook made by TR.EM. when sailing on a ferry through Sydney Bay or on board a Caribbean catamaran!

TR.EM. is my life. My family. My story. A story of dreams, of hard work, a story of sacrifice and challenges, a story of happiness and pride. So I would also like to thank our employees as well as our customers for the trust shown over the years and I look forward to spending another 50 years at sea with you all.



50 ANNI DI STORIA YEARS OF HISTORY



TR.EM., LE TAPPE DELLO SVILUPPO

1968 - Il 9 febbraio nasce la società TR.EM. che, in un garage di Ozzano Emilia, inizia a produrre reti elastiche salvagonna per le ruote posteriori delle biciclette da donna. In dotazione, due macchine trecciatrici e due dipendenti.

1970 - La produzione si diversifica con i ganci elastici per portapacchi e, di seguito, con le corde per il settore nautico. L'azienda comincia anche a lavorare con l'estero.

1975 - TR.EM. cresce e vengono affittati alcuni locali a Osteria Grande.

1982 - Nasce il primo insediamento al civico 5 di via Friuli a Osteria Grande. Viene realizzato uno stabilimento di 12.000 mq con i reparti falegnameria, corderia, officina meccanica e un magazzino spedizioni di 3.000 mq.

1989 - Alla sede viene aggiunto un capannone di 3.000 mq per lo stampaggio a iniezione di materie plastiche e la realizzazione degli stampi con relativo progetto.

1992 - In via Abruzzo viene realizzato il capannone di 3.000 mq dedicato alla gestione delle materie prime.

2007 - Viene costruito un ulteriore magazzino di circa 2.000 mq in via Abruzzo per la gestione delle materie plastiche.

2018 - Oggi l'azienda si estende su circa 20.000 mq, 8.000 dei quali riservati a magazzino. TR.EM. ha un'ottantina di dipendenti, un catalogo con oltre 10.000 articoli, circa 3.000 clienti in Italia e all'estero. L'export copre la metà del fatturato che, nel 2018, si è attestato intorno ai 12 milioni di euro.

TR.EM., THE DEVELOPMENT STAGES

1968 - TR.EM. Company was born on February 9th in a garage in Ozzano Emilia, producing elastic nets for the rear wheels of women's bicycles. At that time the company consisted of two braiding machines and two employees.

1970 - The production range grows with elastic hooks for luggage racks, followed by ropes for marine sector. TR.EM. also begins to operate on the foreign markets.

1975 - TR.EM. grows further and some premises are rented in Osteria Grande.

1982 - The first settlement was born at number 5 of via Friuli in Osteria Grande. A 12,000 sqm factory is built with the carpentry, rope, mechanical workshop departments, and a 3,000 sqm shipping warehouse.

1989 - A 3,000 sqm square meter warehouse is added to the site for injection molding of plastic materials and the production of the molds with relative project.

1992 - In via Abruzzo a 3,000 sqm warehouse dedicated to the management of raw materials is built.

2007 - A further warehouse of about 2,000 sqm is built in via Abruzzo for the management of plastic materials.

2018 - Today the company covers approximately 20,000 sqm, 8,000 of which are dedicated to the warehouse. TR.EM. has about 80 employees, a catalog with over 10,000 items, around 3,000 customers in Italy and abroad. Exports cover half of the turnover which, in 2018, amounted to around 12 million euros.



Franco Marzaduri con i figli Davide e Massimiliano e la moglie Lorena durante i festeggiamenti per la grande festa del Cinquantenario.



Franco Marzaduri with his sons Davide & Massimiliano and his wife Lorena during the big party celebrating the 50th of TR.EM.



Il complesso esteso su una superficie complessiva di 23.000 mq.
TR.EM Company plant with a total surface of some 23,000 sqm.

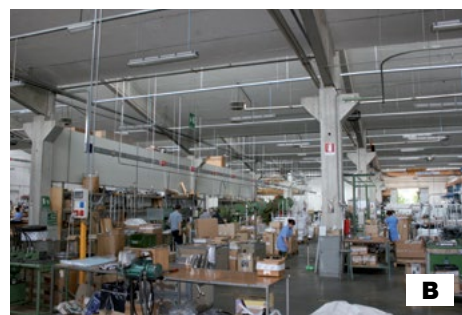

1 1982

Nel 1982 nasce il primo insediamento al civico di via Friuli 5. Si tratta di uno stabilimento di 12.000 mq al cui interno sorgono: la corderia (A), l'officina (B), la falegnameria (D) e il magazzino (C) con oltre 10.000 articoli, gestiti con i più elevati mezzi tecnologici. In 1982 a new plant of 12,000 sqm is founded. Here there are: the rope production plant (A), the workshop (B), the carpentry (D) and a large warehouse for the storage of more than 10,000 articles.

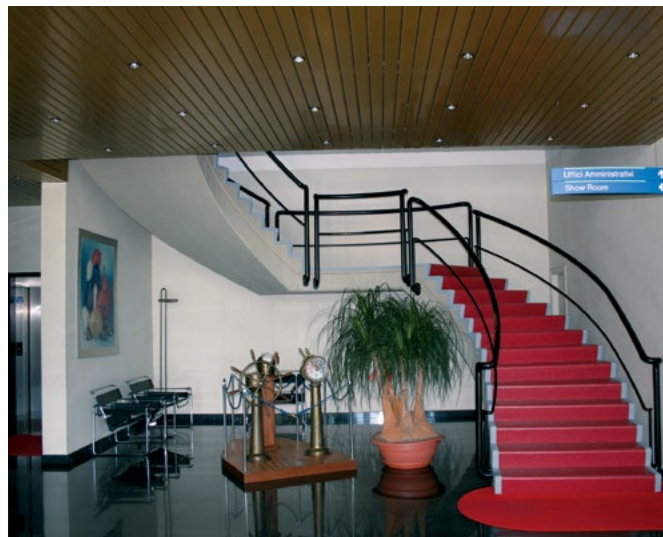

2 1985

Nel 1985 nascono gli uffici e il magazzino spedizioni di 3.000 mq.
In 1985 the headquarters and the warehouse of 3.000 sqm are founded.

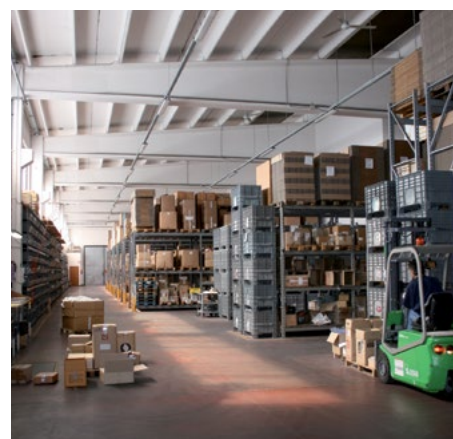
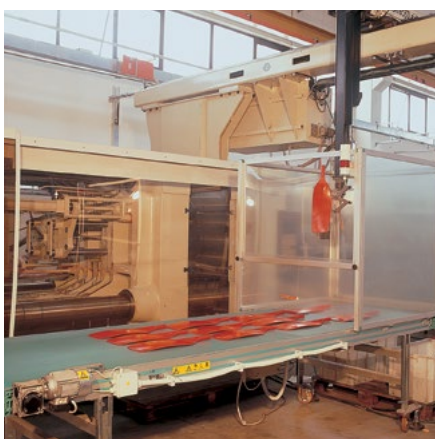

3 1989

Nel 1989 nasce lo stabilimento di 3.000 mq per lo stampaggio a iniezione delle materie plastiche e la realizzazione degli stampi e relativo progetto.
In 1989 the plastic injection workshop of 3.000 sqm is founded.

4 1992

Nel 1992 nasce in via Abruzzo lo stabilimento di 3.000 mq per la gestione delle materie plastiche e la componistica.
In 1992 the new components warehouse of 3,000 sqm is founded.



5 2007

Nel 2007 viene realizzato un ulteriore magazzino di 2.000 mq in via Abruzzo.
In 2007 a new plant of 2,000 sqm is founded.

VISIT OUR B2B AREA

CREATE A CUSTOMER ACCOUNT
CHECK AVAILABILITY & QUANTITY OF ITEMS
CHECK YOUR COMMERCIAL CONDITION
PLACE YOUR ORDER
TRACK YOUR ORDER STATUS
TRACK YOUR PAYMENT PROCESS

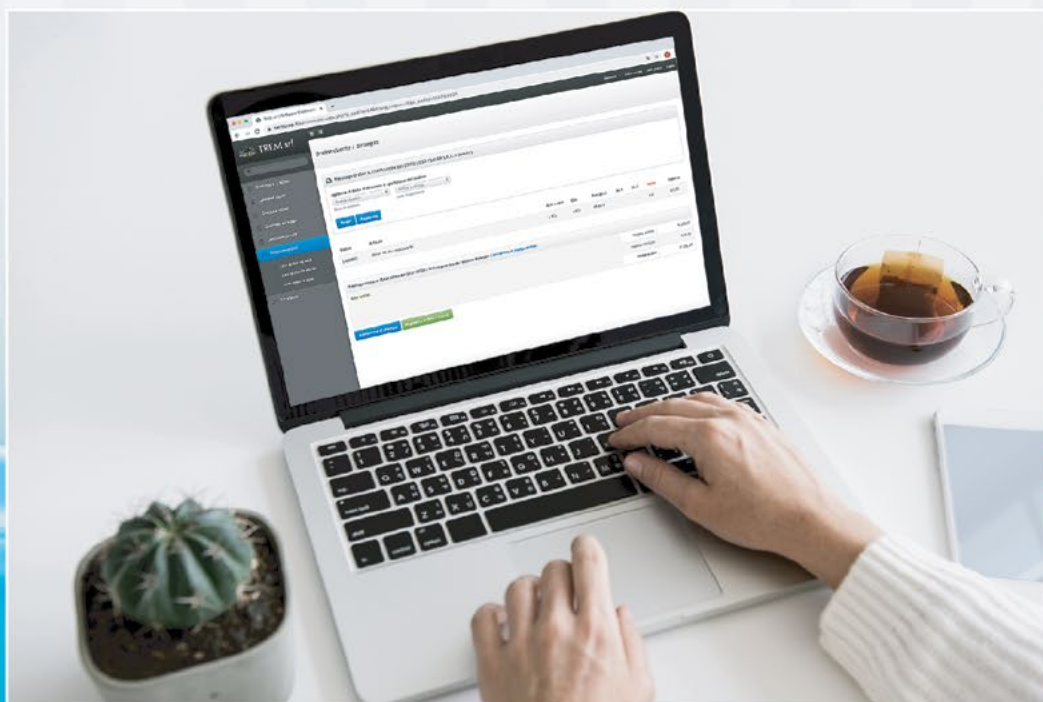

WWW.TREM.NET





LET'S STAY IN TOUCH
& FOLLOW US ON SOCIAL MEDIA!



@TremItaly
#tremitaly

CONTACT US!



+39 340 2747740



export@trem.net



commerciale@trem.net



www.trem.net

| | | |
|---------------|---|--|
| 01 16-23 | Cima da vela Sailing rope | |
| 02 24-29 | Cima da ormeggio Mooring rope | |
| 03 30-36 | Trecce multiuso e corde elastiche Multipurpose rope | |
| 04 37-44 | Ganci e accessori cime Hooks & Accessories | |
| 05 45-64 | Accessori ormeggio e ancoraggio Mooring & Anchorage | |
| 06 65-95 | Ferramenta nautica Marine Hardware | |
| 07 96-123 | Sicurezza Safety | |
| 08 124-129 | Bandiere e linee di galleggiamento Flags & Adhesive tapes | |
| 09 130-133 | Accessori per battelli pneumatici Accessories for rubber boats | |
| 10 134-142 | Parabordi e accessori Boat fenders & Accessories | |
| 11 143-162 | Luci di navigazione Navigation lights | |
| 12 163-171 | Fari Spotlights | |
| 13 173-195 | Luci interno ed esterno Indoor & Outdoor lighting | |
| 14 197-274 | Materiale elettrico Electrical equipment | |
| 15 275-286 | Indicatori e strumenti di livello Engine instruments | |
| 16 287-311 | Strumenti di guida Steering | |
| 17 312-321 | Casseri e poltroncine Quarter decks & pilote seats | |
| 18 322-333 | Sportelli, molle a gas e oscuranti Hatches, gas springs & curtains | |

| | | |
|---|--|----------------------|
|  | Teli e capottine Bimini tops & boat covers | 19 334-351 |
|  | Carrelli, argani e alaggio Trolleys & winches | 20 353-365 |
|  | Contenitori, reti e sacche Pockets, bags & elastic nets | 21 366-378 |
|  | Ventilatori e prese d'aria Ventilation | 22 379-383 |
|  | Pulizia e manutenzione a bordo Washing & boat maintenance | 23 384-405 |
|  | Accessori acqua Water accessories | 24 406-453 |
|  | Accessori carburante e motore Fuel tanks & engine accessories | 25 455-512 |
|  | Supporti motore e prolunghe Motor brackets & extension handles | 26 514-520 |
|  | Mezzi marinai e remi Boat hooks & oars | 27 521-529 |
|  | Scale, passerelle e gruette Boarding ladders, gangways & davits | 28 530-550 |
|  | Cucina e lavelli Melamine crockery & sinks | 29 552-570 |
|  | Accessori vela Sailing accessories | 30 571-577 |
|  | Accessori canoa e sci nautico Water sports & canoe | 31 578-579 |
|  | Tavoli e poltroncine Tables & seats | 32 580-587 |
|  | Cuscini e abbigliamento Cushions & boat clothing | 33 588-589 |
|  | Articoli da regalo e gadget Gifts & gadgets | 34 590-594 |
|  | Blisters ed espositori Blisters & displays | 35 595-599 |

| A | |
|--|----------------------|
| Accendisigari x pannello | 240 - 244 |
| Accessori per poltroncine | 320 |
| Accessori pulizia TBRITE | 384/391 |
| Accessori quadri elettrici | 219 |
| Accessori acqua | 406/453 |
| Accessori canoa sci nautico | 578/579 |
| Accessori carburante e vano motore | 455/512 |
| Accessori carrelli | 362/365 |
| Accessori doccette e rubinetti | 413 |
| Accessori dotazioni | 120 |
| Accessori elettrici vari | 274 |
| Accessori gas | 561/563 |
| Accessori gommoni | 399 |
| Accessori musoni | 56 - 57 |
| Accessori ormeggio | 54 - 60 |
| Accessori ormeggio e ancoraggio | 45/64 |
| Accessori per argani | 360 |
| Accessori per capottine tendalini | 338/340 |
| Accessori per cucina | 566 |
| Accessori per impiombare | 38-39 |
| Accessori per strumenti di livello | 277 |
| Accessori per T-TOP | 335 |
| Accessori poltroncine di guida | 312 -313 -318/321 |
| Accessori pompe elettriche | 432 |
| Accessori pulpiti | 70/78 |
| Accessori remi e mezzi marinai | 527/529 |
| Accessori ricambi passerelle | 532/536 |
| Accessori sci nautico | 579 |
| Accessori sportelli | 326 |
| Accessori teli covy line | 350 - 351 |
| Accessori tender e battelli | 133 |
| Accessori vela | 571/577 |
| Accessori viteria | 93/95 |
| Accessori wc | 442 - 443 |
| Additivi antialga - diesel -benzina | 396 |
| Adesivi , nastri e tessuti per riparazioni | 399/401 |
| Adesivi bandiere e linea galleggiamento | 124/129 |
| Adesivi con 25 utenze per interruttori a bascula | 254 |
| Adesivi per riparazioni | 400 |
| Adesivi per riparazioni e antisdrucchiolo | 401 |
| Adesivi sigillanti SIKA | 398 |
| Adesivo per interruttore a bascula | 244 - 254 |
| Aeratore da appoggio | 379 |
| Aghi e punteruolo | 39 - 571 |
| Altoparlanti | 270/273 |
| Amaca portaoggetti | 590 |
| Amperometro | 220 - 221 |
| Amperometro GAUGE LINE | 278/280 |
| Amperometro X- LINE | 281/285 |
| Amplificatore bluetooth | 273 |
| Ancore | 47/49 |
| Ancore galleggianti | 47 |
| Anelle -anellini in acciaio inox | 38 |
| Anello traino sci nautico | 579 |
| Anello lancia sagole | 43 |

| Anemometri | 304 |
|---|------------------|
| anodi | 480/509 |
| Antenna a baffo | 270 |
| Antenne tv vhf e radio | 306/308 |
| Antifurti | 519 |
| Antifurto x carrello | 363 |
| Antiruggine e vernici per motori | 404 |
| Antisdrucchiolo | 401 |
| Antitopo | 43 |
| Antivegetative HEMPEL | 402/404 |
| Appendiabiti, chiusure, ferma paglioli | 82/87 |
| Argani elettrici | 361 |
| Argani manuali | 360 |
| Arrotolatore per cavi | 239 |
| Arrotolatore per cinghia | 60 |
| Arrotolatore salvavita per spiaggia | 99 |
| Articoli da regalo e oggettistica | 590 |
| Asta traino sci nautico | 579 |
| Aste bandiera | 128 - 129 |
| Aste fanali | 144 /149 |
| Aste fanali 360° | 152/155 |
| Astine segnavento | 575 |
| Attacchi e ricambi molle | 330 |
| Attrezzo per impiombature mod.per manicotti circolari | 74 |
| Autoclave per pannello | 246 |
| Autoclavi Flojet | 425 - 429 |
| Autoclavi, pompe di sentina, giranti | 424 - 425 |
| Avvisatori acustici e campane | 113 |
| Avvisatori acustici e trombe | 268/269 |
| Avvolgitori e tubi | 392 |
| B | |
| Bandelle segnavento | 575 |
| Bandiere e codici adesivi | 124 -126 |
| Bandierina segnavento | 575 |
| Bandierine da regata | 124 |
| Bansigo | 104 |
| Barbecue | 555 |
| Barometri Orologi igrometri | 123 |
| Barra posteriore con luci | 365 |
| BARRE DI CONNESSIONE BLUE SEA SYSTEM | 206 - 207 |
| Barre prolunga di guida | 519 |
| Base girevole per poltroncine | 321 |
| Basette bitte | 62/64 |
| Basi e tubi gambe tavoli | 586 -587 |
| Basi per antenne | 309 |
| Basi per asta portabandiera | 73 - 128 -169 |
| Basi poltroncine di guida fisse | 319 |
| Basi poltroncine di guida telescopiche | 319 |
| Basi pulpiti e accessori | 56 - 70/73 |
| Batiscopio | 123 |
| Batterie e cassette porta batterie | 223/225 |
| Bauetto portaoggetti | 326 |
| Beccucci per gonfiatori | 132 |
| Bicchieri e posate | 566 |
| Bici Pieghevoli e accessori | 594 |

| Bilancino | 536 |
|--|-----------|
| Binocoli | 121 |
| Bitte | 60/64 |
| Bobina avvolgicima per battagliola (priva di cima) | 96 |
| Bobinette treccina poliestere alta tenacità | 31 |
| Boe da regata | 577 |
| Boe e gavittelli | 142 |
| Boette-Supporti- lampadine | 109 |
| Boiler | 452 |
| Bombolette per avvisatori acustici | 113 |
| Borchie | 41 |
| Borsa vuota adatta a contenere la dotazione obbligatoria | 114-115 |
| Borse per giubbotti | 101 |
| Bottoni occhioli e tornichetti | 350 - 351 |
| Bozzellame | 573 |
| Braccio per ecoscandaglio | 311 |
| Bussole | 300/303 |
| Busta contenitore per tendalino | 340 |
| Buste porta documenti impermeabili | 377 |
| C | |
| Calza copri winch | 347 |
| Calza coprielica | 348 |
| Calza copriparabordi | 138 - 139 |
| Calza proteggi parabordi | 138 |
| Campane di bordo | 113 |
| Candele | 479 |
| Candelieri - corrimano | 73 |
| Canestri carburante | 455 - 456 |
| Capicorda | 38 - 227 |
| Capottine tendalini in alluminio e inox | 334/337 |
| Cappucci per interruttori | 251 |
| Caraffa Graduata Per Miscela | 459 |
| Carica batterie | 223 - 233 |
| Caricatore USB 12/24 volt | 241 |
| Carrelli alaggio | 356 |
| Carrelli portamotore | 518 |
| Carrelli portatutto KANGURO PLUS | 357 |
| Carrello porta canoa | 357 |
| Carrucola svolgicatenata o svolgicima per battagliola | 56 |
| Carta igienica biodegradabile | 393 |
| Carteggio nautico | 122 |
| Cartucce - Filtri | 468-477 |
| Casse stereo | 271 |
| Casseri - gavoni - poltroncine -basi | 312/321 |
| Cassetta Atrezzi | 93 |
| Cassetta portabatteria e vaschette p/ batteria | 223/225 |
| Cassette di pronto soccorso | 111 |
| Catadiottri | 365 |
| Catena | 58 |
| Cavalletti portamotore | 518 |
| Cavi batterie a accessori | 227 |
| Cavi di alimentazione da banchina | 234/236 |
| Cavi flessibili per telecomando- kit telecomando | 291 |
| Cavi per timoneria | 292 -295 |

| | |
|--|-----------|
| Cavi Telecomando | 291 - 296 |
| Cavo di sicurezza per motori fuoribordo | 517 |
| Cavo in acciaio | 74 |
| Cavo ingresso USB/AUX | 272 |
| Cavo prolunga rimorchio | 365 |
| Centralina Di Ricambio Per Passerelle Elettriche 12v-24v | 537 |
| Centralina elettronica per tergilistrelli | 267 |
| Cerniere | 79/81 |
| Cesoia | 43 |
| Cestelli portaparabordi | 140 - 141 |
| Cestino-Trolley doppio uso | 594 |
| Chiave di sicurezza motore con laccio/ moschettone | 479 |
| Chiave gambetti | 66 |
| Chiusure, fermapaglioli, appendiabiti, maniglie | 82/87 |
| Ciabatta SCHUKO 3PRESE+USB MT. 1,5 | 238 |
| Cima con piombo | 17 - 29 |
| Cima da ancora | 28/29 |
| Cima da ormeggio | 24/29 |
| Cima per parabordi | 30 |
| Cime da lancio e cime di sicurezza | 99 |
| Cime da lancio e cime di sicurezza | 96-99-100 |
| Cime da vela | 17/23 |
| Cime galleggianti | 96 |
| Cinghia puntapedi per Imbarcazioni | 36 |
| Cinghia in velcro multiuso | 44 |
| Cinghie di carico | 36 |
| Cinghietti salvaocchi | 590 |
| Cinture di sicurezza e cinghie sicurezza | 105/108 |
| Clips portaremi-collari-scalmi | 529 |
| Codice di navigazione GRAN PAVESE | 124 |
| Codici adesivi | 126 |
| Collare di ricambio per remi | 527 |
| Colle e sigillanti | 398 |
| Coltelli | 591 |
| Coltelli nautici | 591 |
| Compassi in acciaio inox e molle a gas | 329/331 |
| Compressori gonfiatori accessori | 130/133 |
| Coni e palloni di segnalazione | 119 |
| Coni turafalle di emergenza | 112 |
| Connettore | 285 |
| Contagiri GAUGE LINE | 278/280 |
| Contagiri X-LINE | 281/285 |
| Contametri e telaio contametri | 43 |
| Contentore con uscita acqua | 406-412 |
| Contentore per salvagente ferro cavallo | 98 |
| Contentori - tasche - reti - sacche | 366/378 |
| Contentori box doccette | 412 |
| Contentori completi doccette e rubinetti | 406/413 |
| Contentori per cime da lancio | 99-100 |
| Contentori pieghevoli | 372 |
| Contentori porta oggetti | 370 |
| Contentori portacellari-ipad-iphone-palmari-macchina fotografica | 366 - 377 |
| Contentori portaoggetti | 367 |
| Copri piede impermeabile | 348 |
| Copricrocette | 572 |

| | |
|--|----------------|
| Copridraglie | 571 |
| Coprimorsetti | 198 |
| Coprisfera ad incastro | 363 |
| Coprisfiati e sfiati | 449-464 |
| Copristereo | 271 |
| Corde per traino sci nautico | 578 |
| Corde elastiche | 34 - 35 |
| Corde traino sci | 578 |
| Cordone ombelicale per cinture di sicurezza | 106 - 107 |
| Corni da nebbia | 112 |
| Corrimano - candelieri | 73 -77-78 |
| Cubia | 56 |
| Cucina e lavelli | 552/570 |
| Cucine a gas | 558-559 |
| Cucine fornelli e piani cottura ENO | 556/560 |
| Cuffie lavaggio motore | 392 |
| Cuffie passacavi timoneria | 449 |
| Culle portazattere complete di cinghie | 116 |
| Cuneo di sicurezza | 365 |
| Cuscini | 317 - 588 -589 |
| Cuscini e schienali per poltroncine | 318 |
| Cuscini salvagente | 588 - 589 |
| D | |
| Dadi in acciaio inox | 95 |
| Detergenti lucidanti protettivi | 394/395 |
| Deumidificatori e assorbenti | 395 |
| Deviatori e staccabatteria | 228/231 |
| Deviatori staccabatteria | 200/202 |
| Deviatori-staccabatteria | 224 - 228 -229 |
| Diluente Hempel | 403 |
| Disgiuntori termici unipolari | 255 |
| Dispositivo antitopo | 43 |
| Distanziali | 549-548 |
| Doccette e contenitori docce e acqua | 406/413 |
| Dotazioni di sicurezza | 115 |
| Drizze e scotte | 17/23 |
| Duck tape | 400 |
| E | |
| Ecoscandagli e Plotter | 310 - 311 |
| Elastici e serravele | 35 |
| Elettroaspiratori | 383 |
| Elettrodomestici vari | 565 |
| Elettropompa | 428-429 |
| Eliografi | 119 |
| EPIRB | 305 |
| Espositore a colonna vuoto per self-service (viteria,fanali,blister) | 595-596 |
| Espositore da banco TLED vuoto | 596 |
| Espositore da tavolo completo di 24 bobine di treccia | 31 |
| Espositore da terra ACQUA/COVY | 598 |
| Espositore da terra LUCI VIA vuoto | 597 |
| Espositore lampadine | 596 |
| Espositore luci sub cablato | 597 |
| Espositore per cime | 595 |
| Espositore rotoli di antisdruciolio | 401 |

| | |
|--|-----------------|
| Espositore TBRITE(pulizia) | 596 |
| Espositore teli covy line- covy Lux | 598 - 599 |
| Espositori | 595/599 |
| Estintori | 112 |
| F | |
| False maglie di giunzione | 58 |
| Fanale di via | 156/162 |
| Fanali al Led Conformi | 161 |
| Fanali di poppa round LED | 161 - 185 |
| Fanali per carrelli | 364 |
| Faretti a led "Aurora" | 174 |
| Fari e prioriettori | 163/171 |
| Fascette | 452 |
| Ferma paglioli ,appendiabiti, chiusure, | 82/87 |
| Fermapentole | 555 |
| Fermapiatti e oggetti | 566 |
| Fermaporte | 82/86 |
| Ferramenta nautica | 65/95 |
| Ferro di cavallo ARES arancio completo di supporto e boetta Vega | 97 |
| Fibbie e passanti per cinghie | 37 |
| Filo per vele | 32 |
| Filtri acqua | 468/478 |
| Filtri benzina e cartucce motori | 468-470 |
| Filtri docce e pompe | 433 |
| Fischietto | 113 |
| Flaps | 311 |
| Fornelli cucine ENO | 556-559 |
| Fornelli e piani cotturaCAN | 552/555 |
| Fornelli portatili | 564 |
| Frattazzo | 385-387 |
| Frigoriferi portatili | 565 |
| Frontalini Stereo | 270 |
| Fun tube | 578 |
| Fuochi di segnalazione | 110 |
| Fusibili | 208/214 |
| Fusibili e portafusibili | 261/263 |
| G | |
| Galleggianti e olive | 142 |
| Galleggianti sonde | 286 |
| Galletti inox | 95 |
| Gambe tavoli e tavoli | 584/587 |
| Gambetti e mezzi anelli | 66 |
| Ganci d'accosto e ormeggio | 385-387-526-527 |
| Ganci e borchie-anelli | 38/42 |
| ganci ed accessori cime | 37/44 |
| Ganci fissa parabordi | 134 |
| Ganci per teli barca | 42 |
| Ganci -piastrine-cerniere per scalette | 547 |
| Ganci-clips-agganci- Fissaggio cime | 44 |
| Gancio d'accosto di ricambio in nylon | 527 |
| Gancio fermacatena o fermacima per battagliola | 56 |
| Gancio pelican in acciaio inox Aisi 316 | 75 |
| Gancio per rimorchio | 363 |
| Gancio traino | 362 |
| Garrocci | 573 |
| Gavitelli | 142 |

| | |
|---|----------------|
| Gavoni e casseri | 317 |
| Gelcoat Filler LOCTITE | 397 |
| Ghiacciaie portavivande | 565 |
| Giochi d'acqua gonfiabili | 578 |
| Giranti | 435/439 |
| Girelle | 59 |
| Giubbotti di salvataggio | 101/103 |
| Giunti salpancore | 59 |
| Glassfibre Filler LOCTITE | 397 |
| Golfari ed anelli | 67 |
| Gonfiabili da traino | 578 |
| Gonfiatori compressori accessori | 130/133 |
| Gonfiatori compressori-pompe a mano | 130/133 |
| Gradini per scale e distanziali | 546-548 |
| Gradino albero | 572 |
| Gran Pavese | 124 |
| Griglie d'aerazione | 380-381 |
| Grilli | 65 - 66 |
| Gruette | 550 |
| Guadino da pesca | 387 |
| Guardapalmo in cuoio | 571 |
| Guida sfilabile per supporto motore | 517 |
| I | |
| Igrometri Orologi barometri | 123 |
| Imbragatura POWER LIFT | 550 |
| Imbuto per travaso carburante | 456-459 |
| Impugnatura per remi e mezzi marinai | 527 |
| Inclinometri | 576 |
| Indicatori di livello GAUGE LINE | 278/280 |
| Indicatori di livello X- LINE | 281/285 |
| Indicatori e strumenti di livello | 276/286 |
| Indicatori galleggianti per serbatoi Big Joe | 455 |
| Innesti carburante | 462 - 463 |
| Innesti rapidi acqua | 413 |
| Interruttori montaggio su batteria | 255 |
| Interruttori Spine prese CBE | 258/260 |
| Interruttori a bascula | 256 |
| Interruttori a bascula e cornici | 254 |
| Interruttori Carlingswitch | 255 |
| Interruttori- deviatori-cornici CBE | 253-258/260 |
| Interruttori e portafusibili | 250-254 |
| Interruttori e pulsanti | 251 - 252 |
| Interruttori e pulsanti | 252 -253 - 254 |
| Interruttori e pulsanti | 253/257 |
| Interruttori magneto idraulici | 213 - 215 |
| Interruttori magneto idraulici | 256 |
| Interruttori magnetotermici | 253 |
| Interruttori pompe | 432-433 |
| Interruttori-spie-deviatori-adattatori-pannelli-prese-scritte BLUE SEA SYSTEM | 246/255 |
| Inverter | 232 - 233 |
| Involucro per salvagente anulare | 98 |
| K | |
| Kit acqua con espositore | 598 |
| kit anello recupero ancore | 47 |
| kit anodi in alluminio | 510/512 |
| Kit conv. 24V base al piano | 442 |

| | |
|---|--------------|
| Kit COVY con espositore | 598 |
| Kit dotazioni sicurezza | 114 - 115 |
| Kit innesti per serbatoi | 422-423 |
| Kit luci led fiss. Magnetico | 365 |
| Kit luci led TLED con espositore | 596 |
| Kit luci posteriori fiss. Magnetico | 364 |
| Kit luci sub AQUALINE con espositore | 163 - 597 |
| Kit mix COVY con espositore | 599 |
| Kit pulizia | 384-385-392 |
| kit segnali di soccorso navigazione | 110 |
| Kit sicurezza mod. POLARIS | 98 |
| L | |
| Lampade portatili | 168 |
| Lampadine | 193/195 |
| Lampadine al led | 193 - 194 |
| Lavatrice | 565 |
| Lavelli e pilette | 421 |
| Led calpestabili | 188 |
| Lettere e numeri adesivi | 127 |
| Linee di galleggiamento | 126 |
| Liquido WC | 393 |
| Lucchetti e antifurti ABUS-cavi | 520 |
| Lucchetto blocca gancio | 362 |
| Luce cortesia | 184/186 |
| Luci da esterno al led | 187 - 191 |
| Luci da esterno alogene | 161 - 191 |
| Luci da interno al led | 178/191 |
| Luci da interno alogene | 189/191 |
| Luci di coperta e fari | 168 |
| Luci di cortesia a led "Aurora" | 175 |
| Luci di navigazione | 144/162 |
| Luci di navigazione al led omologate | 156/162 |
| Luci di navigazione omologate CONFESIONE CANTIERI | 156/159 |
| Luci interno ed esterno | 174/195 |
| Luci subacque | 163/166 |
| Luci via 360°led 12-24V | 160 - 597 |
| M | |
| Macchina caffè 12 v. | 274 |
| Maceratore wc | 443 |
| Magnetotermici CC | 212 - 214 |
| Maniche a vento | 333 |
| Manicotti alluminio-rame | 76 |
| Maniglia leva-drappe | 60 |
| Maniglie in alluminio-inox-plastica | 73-77-78-546 |
| Maniglie per Winch | 576 |
| Maniglie usi vari | 576 |
| Maniglioni tientibene | 78 |
| Marmitta di Scarico | 460 |
| Materiale elettrico | 198/274 |
| Megafono | 268 |
| Melamina e stoviglie | 566/570 |
| Mezzi marinai - remi - raffi | 521/529 |
| Millepiedi | 35 |
| Miscelatori e rubinetti | 414/420 |
| Mix doccia | 413 |
| Molle a gas | 329/331 |

| | |
|--|----------------|
| Molle ormeggio | 50 - 51 |
| Morsetti | 76 |
| Morsettiere - porta terminali-barre di connessione | 203 -226 - 227 |
| Morsettiere porta terminali | 263 |
| Moschettoni regolamentare per sci nautico | 579 |
| Moschettoni | 68 - 69 |
| Musoni | 52 /56 |
| N | |
| Nastri in nylon per argani manuali | 360 |
| Nastro adesivo per linee di galleggiamento | 126 |
| Nastro riflettente omologato (adesivo) | 96 |
| Nicchia Carburante Galaxy | 465 |
| Nicchie portaoggetti | 328 - 329 |
| Nodi per cavi | 198 |
| Numeri e lettere adesivi | 127 |
| O | |
| Oblò | 332 |
| Occhio ad anello passante in acciaio inox | 67 |
| Oli e lubrificanti | 396 |
| Olio idraulico | 297 |
| Olive Clips per fissaggio corda elastica | 40 |
| Olive e galleggianti | 142 |
| Ombrinali | 448 |
| Ombrinali di scarico | 447 /449 |
| Orecchietta Copri Sfiato | 449 |
| Orologi barometri igrometri | 123 |
| P | |
| Pagaie e remi | 521/523 |
| Pale e impugnature per remi e mezzi marinai | 527 |
| Palline segnalazione cima | 576 |
| Palloni e coni di segnalazione | 119 |
| Pannelli con commutatori a camme CA-AC | 217 |
| Pannelli di comando a interruttori | ???? |
| Pannelli elettrici | 244/248 |
| Pannelli staccabatteria serie 360 | 199 |
| Pannello carichi sporgenti | 363 |
| Pannello di comando a 12V. per pompe di sentina | 433 |
| Panno in PVA e guanto per pulizia | 389 |
| Parabordi ed accessori | 134/142 |
| Parabordi gonfiabili | 134 |
| Parabordi Majoni | 135/141 |
| Parabordi TR.EM | 134 |
| Parabordi TREM | 134 |
| Passacavi | 203 |
| Passacavi | 60 |
| Passacavi cubie | 54 |
| Passanti per Cinghia | 37 |
| Passascotte | 573 |
| Passerelle elettriche | 535 |
| Passerelle fisse e pieghevoli | 530/537 |
| Passi uomo | 332 |
| Pasta Per Pulire Metalli Inox Ottone e Allu | 394 |
| Pennelli - spatole -rulli | 405 |
| Phon | 274 |

| | |
|--|-------------|
| Piani cottura | 556/560 |
| Piani tavolo | 586 |
| Piano cottura e fornelli CAN | 552/555 |
| Piastra bitte | 62/64 |
| Piastre Regolabili per fissaggio porta-motore | 514 |
| Piastre stabilizzatori | 311 |
| Piatti-vassoi-ciotole-tazzine- stoviglie in melamina | 568-570 |
| Pilette per lavelli | 421 |
| Pinza per fissaggio anellini | 38 |
| Pinza tagliacavi- pinza impiombatrice | 74 |
| Plafoniere | 176 - 191 |
| Plancette | 545 |
| Plancette complete di scaletta | 545 |
| Plotter e Ecoscandagli | 310 - 311 |
| Poltroncine di guida | 312/316 |
| Poltroncine di guida complete di base telescopica | 316 |
| Poltroncine e sgabelli | 580/583 |
| Poltrone di guida imbottite | 312/315 |
| Pompa lavelli | 428-430 |
| Pompa a girante uso esterno | 425 |
| Pompa idraulica trim | 311 |
| Pompe a mano | 431 |
| Pompe acqua manuali | 130/133 |
| Pompe elettriche a immersione per sentina | 426/430 |
| Pompe olio e imbuti per travaso | 458-459 |
| Pompe per vasche pesci e ittiche | 428 |
| Pompette carburante | 460 - 461 |
| Ponticelli | 76 |
| Porta carta igienica coperchio impermeabile | 393 |
| porta doccetta con tubo | 408 |
| Porta surf- Kayak | 549 |
| Portabandiera | 128-129 |
| Portabicchieri portaborraccia e supporti | 370 - 371 |
| Portacanne | 88/92 |
| Portachiavi | 592- 593 |
| Portafusibili | 207/211 |
| Portafusibili e fusibili | 261/263 |
| Portafusibili e Interruttori | 250-254 |
| Portagomma per serbatoi | 446-453-451 |
| Portamaniglie winch | 369 |
| Portancore e maniglie winch | 369 |
| Portaoggetti | 372 |
| Portaparabordi e morsetti | 140 - 141 |
| Portasacchetti rifiuti | 393 |
| Portascalmi e scalmi | 528 |
| Portascalmi in Delrin avorio | 528 |
| Portazattere | 116 - 117 |
| Portelli d'ispezione | 322/325 |
| Portello per barche motore/vela | 332 |
| Posacenere | 590 |
| Posate bicchieri | 569 |
| Prese accendisigari | 240 - 244 |

| | |
|--|----------------|
| Prese d'aria | 380 - 381 |
| Prese e interruttori- deviatori-cornici CBE | 253-258/260 |
| Prese e spine - passacavi- adattatori- prolunghes cavo | 234/243 |
| Prese e spine Ratio | 234 |
| Prese e spine T POWER | 235 |
| Prese Spine interruttori CBE | 258/260 |
| Prese USB | 243 - 244 |
| Prese, spine e cavi di alimentazione ELECTRA | 235 |
| Prigionieri per bitte | 62 |
| Primer e fondi Hempel | 403 |
| Prodotti pulizia TBRITE | 388-390 |
| profili di protezione cime | 44 |
| Proiettori e ricambi | 167/171 |
| Proiettori impermeabili | 167 - 171 |
| Prolunga barra timone | 574 |
| Prolunga Per Imbuto | 459 |
| Prolunga timone e snodi in acciaio | 574 |
| Prolunghe accelerazione | 519 |
| Proteggi Crocette | 572 |
| Proteggi parabordo | 138 |
| Proteggi tenditori arridatoi | 572 |
| Protettivo Incolore Per Legno Teak E Doussiè | 395 |
| Protezioni per vela | 572 |
| Protezioni pontili in pvc bianco gonfiabile | 139 |
| Pulizia manutenzione riparazioni a bordo | 384/405 |
| Pulizia WC | 393 |
| Pulpiti di poppa in acciaio inox Aisi 316 | 73 |
| Pulpiti e maniglie | 73 - 77/78 |
| Pulsanti e interruttori a bascula | 252 -253 - 254 |
| Pulsanti per interruttori Carling Contura CC-DC | 216 |
| Pulsantiera per telecomando passerelle | 394 |
| Punteruolo in acciaio inox per impiombature | 38 |
| Q | |
| Quadri elettrici | 217 - 218 |
| R | |
| Raccordi | 451 |
| Radio audio video JENSEN e accessori | 270/272 |
| Radiocomandi per verricelli | 45 |
| Raffi | 526 |
| Redance nylon-inox | 38 |
| Remi e pagaie | 521/523 |
| Resine epossidiche Hempel | 403 |
| Reti cuccette e salvacadute | 368 |
| Reti e teli per battagliole | 369 |
| Reti portaoggetti | 366/368 |
| Ricambi accessori scalette e plancette | 546/548 |
| Ricambi e accessori per timonerie idrauliche | 290 |
| Ricambi molle ed attacchi | 330 |
| Ricambi per pannelli elettrici | 250 -254 |
| Riflettori radar e attacco a basetta | 118 - 119 |
| Riparazione vele | 571 |
| Riserva Di Galleggiamento Per Canoe -Kayak - Optimist | 577 |
| Rivetti in acciaio inox - alluminio | 95 |

| | |
|--|-----------------|
| Rolè automatici | 204 |
| Roll bar | 549 |
| Rubinetti e miscelatori | 414/420 |
| Rubinetti gas | 561/563 |
| Rulli - barre - supporti- morsetti -di ricambio per carrelli | 358 |
| Rulli alaggio | 353 |
| Rulli di ricambio per musoni | 56 - 57 |
| Ruote - carrelli - rulli - argani alaggio | 353/365 |
| Ruote e ruotini di ricambio | 359 |
| Ruote alaggio | 354 - 355 |
| Ruote timone in acciaio inox | 287/288 |
| S | |
| Sacca contenitore per salvagente | 98 |
| Sacca per passerella | 537 |
| Sacca porta cavi | 238 |
| Sacca porta motore ausiliario | 347 |
| Sacca portabici | 594 |
| Sacca Pronto Soccorso tabella D | 111 |
| Sacche - zaini- tasche | 374/378 |
| Sacche e zaini stagni SHARK | 374/376 |
| Sacche porta cima | 378 |
| Saldatore | 274 |
| Salpancore e verricelli elettrici e accessori | 45 - 46 |
| Salvagenti anulari e salvagenti ferro-cavallo | 96/99 |
| Sassole - coni otturafalle | 112 |
| Scaldabagni | 452 |
| Scale passerelle plancette gruettes rollbar | 530/550 |
| Scale di salvataggio Emergency | 120 |
| Scalette | 538/544 |
| Scalmi e portascalmi | 528 - 529 |
| Scandaglio a mano | 311 |
| Scarichi a mare sfiati-boccole | 447 /449 |
| Scotte e drizze | 17/23 |
| Scudi proteggi prua | 46 |
| Secchi | 390 |
| Sedile di ricambio per WC e ricambi WC | 442-443 |
| Sedile e Schienale Di Ricambio Per Poltroncine | 583 |
| Segnacatena | 58 |
| Segnavento | 575 |
| Sensori gas | 381 |
| Sensori di livello | 286 |
| Serbatoi | 422-423-445-457 |
| Serbatoi acqua-raccordi-bocchettoni-tappi-portagomma | 422-445-453 |
| Serbatoi acque chiare | 422 - 423 |
| Serbatoi acque nere | 445 |
| Serbatoi carburante | 455 -457 |
| Serbatoi espansione | 434 |
| Serie Fanali Led Omologati | 149 - 150 |
| Serie Fanali Mini Star Easy Led Omologati | 167 |
| Serravele | 35 |
| Sfera x gancio traino | 362 |
| Sfiati e coprisfiati | 464 |

| | |
|---|-----------------|
| Sfiati e scarichi a mare-boccole | 446-447-448-464 |
| Sgabello e poltroncine | 580/583 |
| Sicurezza | 96/123 |
| Sifoni e scarichi | 460 |
| Sigillanti e colle | 398 |
| Simboli adesivi utenze elettriche | 251 |
| Sistema di recupero uomo a mare mod. ARIETE LIGHT Conf. | 99 |
| Sistemi Audio video "JENSEN" | 272 |
| Slitta per poltroncina | 320/321 |
| Snodi | 546 |
| Soffietto pr gancio rimorchio | 363 |
| Solenoid BLUE SEA SYSTEM | 199 - 204 |
| Sonda di Pitot per speedometro | 282 |
| Spatole-pennelli-rulli | 405 |
| Spazzolino wc | 393 |
| Spazzolone - spazzole -manico per pulizia | 384-388 |
| Specchietto di segnalazione eliografo | 119 |
| Specchio Retrovisore per sci nautico fissaggio Universale | 579 |
| Speedometro GAUGE LINE | 278/280 |
| Speedometro X-LINE | 281/285 |
| Spie Luminose | 216 |
| Spie Luminose | 253 |
| Spine e prese | 234/243 |
| Spine e prese - passacavi- adattatori-prolunghe cavo | 234/236 |
| Spine e prese Ratio | 234 |
| Spine prese e interruttori CBE | 258/260 |
| Sportelli - oblò - molle a gas - oscuranti | 322/333 |
| Sportelli e bauletti vari | 326 |
| Spugna | 388 |
| Stabilizzatori / Sostentatori Hydrofo Fin | 311 |
| Staccabateria e deviatori | 228/231 |
| Stacchi automatici di sicurezza | 479 |
| ST-Blade portafosibili | 205 |
| Stecche vela | 572 |
| Stereo e altoparlanti BOSS marine | 270/273 |
| Stick | 574 |
| Stoviglie in melamina | 566/570 |
| Strozzacime | 573 |
| Strumenti di guida | 287/311 |
| Strumenti di livello | 276/285 |
| Strumenti di livello ECO LINE | 276/277 |
| Strumenti di livello GAUGE LINE | 278/280 |
| Strumenti di livello X-LINE | 281/285 |
| Strumenti digitali CC-DC | 220/221 |
| Stucchi Hempel | 403 |
| Succhiarola in ottone per sentina | 448 |
| Super PUMP con tubo | 459 |
| Supporti a parete TV | 274 |
| Supporti e attacchi passerelle | 536 |
| Supporti e basi per corrimano e tientibene | 70/72 |
| Supporti motore | 515/517 |
| Supporti motore e prolunghe accelerazione | 514/520 |
| Supporti per anulari, salvagenti, cime e ferri cavallo | 100 |

| | |
|---|-------------|
| Supporti per molle a gas | 330 |
| Supporti per poltroncine | 319 |
| Supporti piedi tavolo | 586-587 |
| Supporti Sedili | 319 |
| Supporto per ruotino | 362 |
| Supporto tv | 274 |
| T | |
| Taniche benzina | 456 |
| Taniche carburante portatili | 455-456 |
| Taniche carburante portatili SCEPTER e accessori | 456 |
| Tappi | 73-422-450 |
| Tappi a espansione e ombrinali | 450 |
| Tappi imbarco | 465/467 |
| Tappi in plastica | 548 |
| Tappi ispezione | 327 |
| Tasche - zaini - sacche | 374/378 |
| Tasche laterali e nicchie | 328 - 329 |
| Tasche portaoggetti | 367 |
| Tasche -serrature-maniglie-tappi per sportelli | 323 - 326 |
| Tavolette poppiera e proteggi poppa | 514 |
| Tavolette porta motore | 515 |
| Tavoli ABS completi di gamba | 585 |
| Tavoli e poltroncine | 580/587 |
| Tavoli in laminato | 584-585-586 |
| Tavoli in teak | 584 |
| Telaio da banco completo di contimetri per misurazione corde e trecce | 43 |
| Telaio porta zattere | 117 |
| Telecomandi bileva e monoleva | 290 |
| Telecomando per argani elettrici | 360 |
| Telecomando per passerella elettrica | 537 |
| Teleruttori e solenoidi | 199 |
| Teleruttori e solenoidi | 199 - 204 |
| Teli copri barca Covy Line | 345 |
| Teli copri console e copri motore CovyLine | 346 |
| Teli copri poltroncine | 320 |
| Teli copribarca COVY LUX | 345 |
| Teli copriconsole COVY LUX | 346 |
| Teli coprirelca | 348 |
| Teli coprimotore COVY LUX | 343 - 344 |
| Teli copriwinch COVY LUX | 347 |
| Teli e capottine | 334/351 |
| Teli rafia Covy Line | 349 |
| Telo tendalini | 340 |
| Teloni in rafia | 349 |
| Tendalini | 334/337 |
| Tendalini inox | 334 |
| Tendalini parasole per l'applicazione sulle imbarcazioni a vela | 334 |
| Tender ed accessori x battelli pneumatici | 130/133 |
| Tendine oscuranti | 333 |
| Tenditori e accessori pulpiti | 73 - 74 |
| Tergicristalli e accessori | 264/267 |
| Terminali fermacorda | 39 |
| Terminali per cavi d'acciaio | 75 |
| Terminali per Stecche vela | 572 |

| | |
|---|-----------|
| Tessuto riparazioni e collanti per gommoni | 399/401 |
| Tessuto sostitutivo per tendalini | 340 |
| Timonerie e accessori | 292/299 |
| Timonerie idrauliche | 297 |
| Timonerie Meccaniche | 292 -299 |
| Torce luminose | 170 |
| Trasmissioni flessibili per telecomando | 291 |
| Travaso olio e carburante | 458 - 459 |
| Treccia avviamento motori | 30 |
| Treccia fucili subacquei | 30 |
| Treccia galleggiante | 33 |
| Treccia multiusi e corde elastiche | 23-30/36 |
| Treccia per traino sci nautico | 33 |
| Triangoli sci nautico | 579 |
| Trombe e Avvisatori acustici | 268/269 |
| T-TOP | 335 |
| Tubazioni - pompette carburante | 460 - 461 |
| Tubi acqua | 453 |
| Tubi aspirazione | 383 |
| Tubi flessibili raccordati per timonerie idrauliche | 290/297 |
| Tubo e basi gambe tavoli | 586 -587 |
| Tubo in PVC retinato | 391 |
| Tubo per doccette | 410 |
| Tubo pistola e attacco per lavaggio ponti | 392 |
| V | |
| Valvole di connessione | 462 |
| Valvole e raccorderia-portagomma | 446 |
| Vasca di scarico doccette | 429 |
| Ventilatori - griglie - prese d'aria | 379/383 |
| Ventilatori e aspiratori solari | 379-382 |
| Vernici HEMPEL | 402-403 |
| Vernici e antiruggine per motori | 404 |
| Verricelli - salpaancore e accessori | 45 - 46 |
| VHF fissi - portatili | 305 |
| Viteria | 94 - 95 |
| Volanti | 287 - 288 |
| Voltmetro | 220 - 221 |
| Voltmetro GAUGE LINE | 278/280 |
| Voltmetro X- LINE | 281/285 |
| W | |
| Wc elettrici | 440 |
| Wc manuali | 441 |
| Z | |
| Zaini - sacche -tasche | 374/378 |
| Zattere e apparecchi galleggianti | 116 |
| Zatterino vuoto per giubbetti | 101 |
| Zerbini | 590 |

IL FUTURO È ELETTRICO

THE FUTURE IS
ELECTRIC



**Scegli le passerelle
a movimentazione elettrica**

**Choose your
servo-assisted gangway**

(pag. 535)



- + ECONOMICA
INEXPENSIVE
- + PULITA
CLEAN
- + ECOLOGICA
ECOLOGICAL
- + LEGGERA
LIGHT
- + FACILE DA INSTALLARE
EASY INSTALLATION
- + ELEGANTE
STYLISH
- + MODERNA
MODERN

Olympic ropes

01

DA 50 ANNI

DNA, TECNOLOGIA, CONTROLLO

La produzione di corde elastiche è l'attività da cui si è sviluppata l'attuale realtà imprenditoriale della TR.EM. e che ha lasciato una traccia indelebile nel DNA e nel nome: Trecciatura Emiliana.

Ancora oggi la produzione di corde elastiche, cime, drizze e scotte di qualsiasi diametro, lunghezza, colore e materiale, riveste un'importanza centrale nell'attività aziendale e viene effettuata in un moderno reparto in cui trecciatrici, bobinatrici e rocchettatrici lavorano tutto il giorno sotto l'attento controllo di esperti operatori.

Il personale specializzato, avvalendosi della migliore tecnologia disponibile sul mercato, controlla costantemente che la materia prima e il prodotto finito rispondano ai requisiti previsti dal sistema qualità e dalla normativa di riferimento.



SINCE 50 YEARS

DNA, TECHNOLOGY, CONTROL

The production of elastic ropes is the business from which TREM developed its current entrepreneurial and left an indelible mark in its DNA and name: Trecciatura Emiliana.

Also today the production of elasticropes, lines, halyards and sheets for sailing, with any diameter, length, color and material is the most important aim for company's business.

The production it self is performed in a modern department, in which braiding machines winding machines and spool winders operate the whole day, carefully controlled by expert operators.

Specialised personnel use the best available technology on the market to check constantly that the raw materials and finished products comply with the requirements of the quality system and reference Standards.

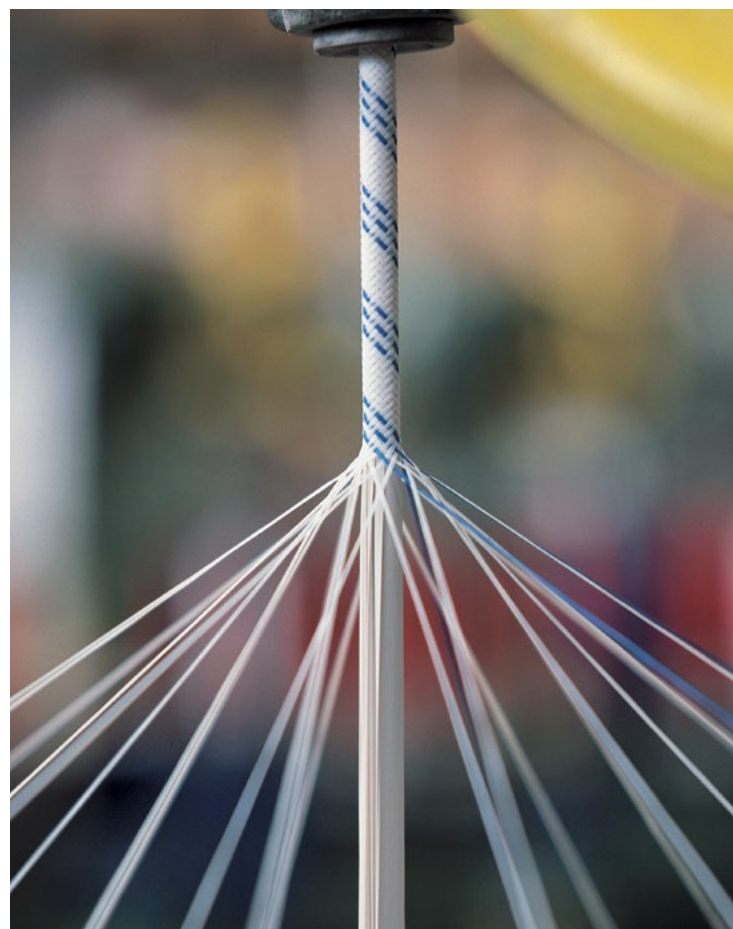
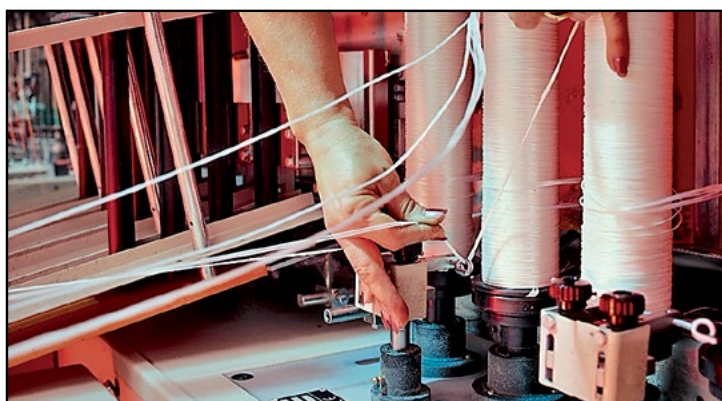

Olympic ropes

01



CARATTERISTICHE TECNICHE DEI FILATI USATI A GARANZIA DELLA QUALITÀ PER LE CIME TR.EM. | RAW

| made by  | Polietilene ad alto modulo PEH | Poliamide PA | Poliestere PES | Polipropilene PP stabilizzato | Polietilene PE |
|---|--------------------------------|--------------------------|---------------------------|-------------------------------|-----------------------|
| Marchi registrati - Registered trademarks | Dyneema - Spectra | Nylon - Perlon - Enkalon | Diolen - Trevira - Dacron | Hostalen - Arova | Lupolen - Vestalen |
| Peso specifico - Specific weight gr/cm3 | 0,96 | 1,14 | 1,38 - 1,41 | 0,91 | 0,96 |
| Allungamento % alla rottura - Breaking stretch | 2-4% | 16-27% | 10-16% | 14-24% | 15-30% |
| Carico di rottura - Breaking load CN/tex | 280/380 | 70/80 | 70/84 | 50/74 | 45 |
| Resistenza al nodo comparato alla resistenza normale - Knot resistance | 35-50% | 60-65% | 55-60% | 55-65% | 50-60% |
| Resistenza all'abrasione a secco - Abrasion resistance (dry) | buona - good | molto buona very good | buona - good | soddisfacente satisfactory | buona - good |
| Resistenza all'abrasione umida - Abrasion resistance (wet) | molto buona very good | buona - good | molto buona very good | buona - good | molto buona very good |
| Assorbimento d'acqua - Water absorption | 0% | 1-7% | 0,5-2% | 0% | 0% |
| Punto di fusione - Melting point | 155°C | 215-250°C | 260°C | 170°C | 150°C |
| Temperatura di lavaggio - Washing temp. | 30°C | 50-60°C | 80-90°C | 30°C | 30°C |
| Resistenza dopo due anni di esposizione alle intemperie - Resistance after 2 years | 90% | 70% | 90% | 90% | 90% |
| Resistenza agli UV - UV resistance | molto buona very good | buona - good | molto buona very good | buona - good | buona - good |

DRIZZA DA REGATA IN DYNEEMA «NORFOLK» | «NORFOLK» DYNEEMA HALYARD

NORFOLK  made by 

Ideale per:

drizze e scotte, a basso stiramento, terzaroli

Particolarità:

scalzabile, facile da impiombare, alta resistenza all'allungamento <1%

Anima:

16 fusi in Dyneema SK75

Calza:

16 fusi (Ø 4) 24 (Ø 6 - 8 - 10) in poliestere, alta tenacità

Confezione:

in bobine

Suitable for:

halyard & sheets, low stretch, reefs

Features:

high tear resistance, low stretch <1%, outstanding, exceptional resistance

Core:





16 plait in Dyneema SK75

Cover:

16 plait (Ø 4) 24 (Ø 6 - 8 - 10) in Polyester, high tenacity

Packing:

reels

| Articolo - Item | €/mt. | €/  | Articolo - Item | €/mt. | €/  | Articolo - Item | €/mt. | €/  | Ø mm. |  mt. | ↑ kg. | ↓ kg. |
|-----------------|-------|--|-----------------|-------|--|-----------------|-------|--|-------|---|-------|--------|
| F 86 06 091 | | | F 86 06 090 | | | F 86 06 092 | | | 6 | 200 | 1600 | 5,480 |
| F 86 08 091 | | | - | | | - | | | 8 | 150 | 2600 | 6,825 |
| F 86 10 091 | | | - | | | - | | | 10 | 150 | 2800 | 10,125 |



CIMA DA VELA | SAILING ROPE

Olympic ropes

01

DRIZZA DA REGATA IN DYNEEMA «AUCKLAND» | «AUCKLAND» DYNEEMA HALYARD

AUCKLAND Dyneema SK75 made by 

Ideale per:

drizze da regata, scotte a basso stiramento, terzaroli

Particolarità:

scalzabile, facile da impiombare, basso allungamento <1%

Anima:

16 fusi in Dyneema

Calza:

24 fusi (Ø 6) 32 (Ø 8 - 10 - 12) in poliestere, alta tenacità

Confezione:

in bobine

Suitable for:

Cruise halyard, low stretch sheets, reefs

Features:

high tear resistance, low stretch <1%, outstanding, exceptional resistance

Core:

16 plait in Dyneema SK75

Cover:

24 plait (Ø 6) 32 (Ø 8 - 10 - 12) in Polyester, high tenacity

Packing:

reels

| Articolo - Item | €/mt. | €/🌀 | Articolo - Item | €/mt. | €/🌀 | Articolo - Item | €/mt. | €/🌀 | Ø mm. | 🌀 mt. | ↑ kg. |
|-----------------|-------|-----|-----------------|-------|-----|-----------------|-------|-----|-------|-------|-------|
| F 94 06 080 | | | F 94 06 075 | | | F 94 06 082 | | | 6 | 200 | 1400 |
| F 94 08 080 | | | F 94 08 075 | | | F 94 08 082 | | | 8 | 150 | 2200 |
| F 94 10 080 | | | F 94 10 075 | | | F 94 10 082 | | | 10 | 150 | 4000 |
| F 94 12 080 | | | F 94 12 075 | | | F 94 12 082 | | | 12 | 100 | 5900 |
| F 94 14 080 | | | F 94 14 075 | | | F 94 14 082 | | | 14 | 100 | 8000 |



CIMA SENZA CALZA IN DYNEEMA «HOBART» | «HOBART» DYNEEMA HALYARD WITHOUT COVER

HOBART Dyneema SK75 made by 

Ideale per:

drizze e trapezi

Particolarità:

non scivola, basso allungamento <1%, flessibile

Anima:

12 fusi in Dyneema

Calza:

priva di calza esterna

Confezione:

in bobine

Suitable for:

Halyard and trapeze

Features:

strong abrasion and low breaking load resistance <1%

Core:

12 plait in Dyneema

Cover:

no cover

Packing:

reels

| Articolo - Item | €/mt. | €/🌀 | Articolo - Item | €/mt. | €/🌀 | Articolo - Item | €/mt. | €/🌀 | Ø mm. | 🌀 mt. | ↑ kg. |
|-----------------|-------|-----|-----------------|-------|-----|-----------------|-------|-----|-------|-------|-------|
| F 62 04 080 | | | F 62 04 075 | | | F 62 04 082 | | | 4 | 200 | 1780 |
| F 62 05 080 | | | F 62 05 075 | | | F 62 05 082 | | | 5 | 200 | 2500 |
| F 62 06 080 | | | F 62 06 075 | | | F 62 06 082 | | | 6 | 200 | 3830 |
| F 62 08 080 | | | F 62 08 075 | | | F 62 08 082 | | | 8 | 150 | 6180 |
| F 62 10 080 | | | F 62 10 075 | | | F 62 10 082 | | | 10 | 150 | 8700 |



CIMA DA VELA | SAILING ROPE

Olympic ropes

01

DRIZZA DA CROCIERA «CRUISE» | «CRUISE» HALYARD

CRUISE POLYESTER HT

Ideale per:
drizze da crociera per manovre correnti

Particolarità:
buona resistenza all'allungamento <3%, facile da annodare

Anima:
16 fusi in poliestere alta tenacità

Calza:
24 fusi (Ø 5 - 6) 32 (Ø 8 - 10 - 12) in poliestere, alta tenacità

Confezione:
in bobine

Suitable for:
halyard for running rigging

Features:
high tear resistance, low stretch <3%, outstanding, exceptional resistance

Core:
16 plait in high tenacity Polyester

Cover:
24 plait (Ø 5 - 6) 32 (Ø 8 - 10 - 12) in Polyester, high tenacity

Packing:
reels

| Articolo - Item | €/mt. | €/🌀 | Articolo - Item | €/mt. | €/🌀 | Articolo - Item | €/mt. | €/🌀 | Ø mm. | 🌀 mt. | ↑ kg. | 📦 kg. |
|-----------------|-------|-----|-----------------|-------|-----|-----------------|-------|-----|-------|-------|-------|--------|
| F 50 05 000 | | | F 51 05 000 | | | F 52 05 000 | | | 5 | 200 | 550 | 4,260 |
| F 50 06 000 | | | F 51 06 000 | | | F 52 06 000 | | | 6 | 200 | 750 | 6,100 |
| F 50 08 000 | | | F 51 08 000 | | | F 52 08 000 | | | 8 | 150 | 1450 | 7,275 |
| F 50 10 000 | | | F 51 10 000 | | | F 52 10 000 | | | 10 | 150 | 2250 | 11,475 |
| F 50 12 000 | | | F 51 12 000 | | | F 52 12 000 | | | 12 | 100 | 2800 | 10,580 |



DRIZZA E SCOTTA DA CROCIERA «MILLENNIUM» | «MILLENNIUM» HALYARD & SHEETS

MILLENNIUM POLYESTER MT

Ideale per:
drizze da crociera e scotta generica per manovre correnti

Particolarità:
buona resistenza all'allungamento <5%

Anima:
16 fusi in poliestere alta tenacità

Calza:
16 fusi (Ø 6 - 8) 24 fusi (Ø 10 - 12 - 14) in poliestere, media tenacità

Confezione:
in bobine

Suitable for:
halyard and sheets for running rigging

Features:
high tear resistance <5%

Core:
16 plait in high tenacity Polyester

Cover:
16 plait (Ø 6 - 8) 24 (Ø 10 - 12 - 14) in Polyester, medium tenacity

Packing:
reels

| Articolo - Item | €/mt. | €/🌀 | Articolo - Item | €/mt. | €/🌀 | Ø mm. | 🌀 mt. | ↑ kg. | 📦 kg. |
|-----------------|-------|-----|-----------------|-------|-----|-------|-------|-------|--------|
| T 30 06 071 | | | T 30 06 075 | | | 6 | 200 | 700 | 4,800 |
| T 30 08 071 | | | T 30 08 075 | | | 8 | 150 | 1400 | 7,500 |
| T 30 10 071 | | | T 30 10 075 | | | 10 | 150 | 2000 | 11,625 |
| T 30 12 071 | | | T 30 12 075 | | | 12 | 100 | 2700 | 10,500 |
| T 30 14 071 | | | T 30 14 075 | | | 14 | 100 | 3400 | 15,000 |



CIMA DA VELA | SAILING ROPE

Olympic ropes

01

SCOTTA DA CROCIERA «SAN DIEGO» | «SAN DIEGO» SHEETS

SAN DIEGO POLYESTER HT MAT

Ideale per:

ideale per scotte, genoa e tutte le cime di regolazione

Particolarità:

superficie ad alto attrito, eccellente tenuta all'abrasione

Anima:

16 fusi in poliestere alta tenacità

Calza:

16 fusi (Ø 6 - 8 -10) 24 (Ø 12) in poliestere peloso (Matt)

Confezione:

in bobine

Suitable for:

genoa and spinnaker sheets and for adjustment ropes

Features:

high tear, very low stretch, very high wear resistance, surface with high friction degree

Core:







16 plait in high tenacity Polyester

Cover:

16 plait (Ø 6 - 8 -10) 24 (Ø 12) in Polyester Mat

Packing:

reels

| Articolo - Item | €/mt. | €  | Articolo - Item | €/mt. | €  | Articolo - Item | €/mt. | €  | Ø mm. |  mt. |  kg. |  kg. |
|-----------------|-------|---|-----------------|-------|---|-----------------|-------|---|-------|---|---|---|
| F 89 06 000 | | | F 90 06 000 | | | F 91 06 000 | | | 6 | 200 | 450 | 4,560 |
| F 89 08 000 | | | F 90 08 000 | | | F 91 08 000 | | | 8 | 150 | 1000 | 6,330 |
| F 89 10 000 | | | F 90 10 000 | | | F 91 10 000 | | | 10 | 150 | 1550 | 8,850 |
| F 89 12 000 | | | F 90 12 000 | | | - | | | 12 | 100 | 2100 | 9,250 |



SCOTTA PER PICCOLE IMBARCAZIONI «CAPE TOWN» | CAPE TOWN» SHEET FOR SMALL LEISURE BOATS

CAPE TOWN POLYESTER HT

Ideale per:

scotte, vang: carico alto/basso, ideale per piccole imbarcazioni

Particolarità:

scorrimento veloce, maneggevole, flessibile

Anima:

16 fusi in poliestere alta tenacità

Calza:

16 fusi (Ø 3 - 4) 24 (Ø 5) 32 (Ø 8) in poliestere, alta tenacità

Confezione:

in bobine

Suitable for:

adjusting of spinnaker sheets, vang, down haul, high-low charge, for leisure boating

Features:

handy and flexible

Core:





16 plait in high tenacity Polyester

Cover:

16 plait (Ø 3 - 4) 24 (Ø 5) 32 (Ø 8) in Polyester, high tenacity

Packing:

reels

| Articolo - Item | €/mt. | €  | Ø mm. |  mt. |  kg. |  kg. |
|-----------------|-------|---|-------|---|---|---|
| F 53 05 082 | | | 5 | 200 | 700 | 4,260 |
| F 53 08 082 | | | 8 | 150 | 1400 | 7,350 |



CIMA DA VELA | SAILING ROPE



Olympic ropes

01

SCOTTA DA CROCIERA «SYDNEY» | «SYDNEY» SHEET

SYDNEY POLYESTER HT

Ideale per:
scotta Cruising per randa e genoa
Particolarità:
maneggevole e a basso allungamento

Anima:
16 fusi in poliestere alta tenacità

Calza:
16 fusi (Ø 6 - 8 - 10) 24 (Ø 12 - 14) in poliestere, alta tenacità

Confezione:
in bobine

Suitable for:
Halyard for genoa and main sail

Features:
high tear resistance, very low stretch, handy

Core:
16 plait in high tenacity Polyester

Cover:
16 plait (Ø 6 - 8 - 10) 24 (Ø 12 - 14) in Polyester, high tenacity

Packing:
reels

| Articolo - Item | €/mt. | €/🌀 | Articolo - Item | €/mt. | €/🌀 | Articolo - Item | €/mt. | €/🌀 | Ø mm. | 🌀 mt. | ↓ kg. | 📦 kg. |
|-----------------|-------|-----|-----------------|-------|-----|-----------------|-------|-----|-------|-------|-------|--------|
| F 78 06 000 | | | F 81 06 000 | | | F 80 06 000 | | | 6 | 200 | 700 | 5,400 |
| F 78 08 000 | | | F 81 08 000 | | | F 80 08 000 | | | 8 | 150 | 1.400 | 7,500 |
| F 78 10 000 | | | F 81 10 000 | | | F 80 10 000 | | | 10 | 150 | 2.000 | 11,400 |
| F 78 12 000 | | | F 81 12 000 | | | F 80 12 000 | | | 12 | 100 | 2.700 | 10,820 |
| F 78 14 000 | | | F 81 14 000 | | | F 80 14 000 | | | 14 | 100 | 3.400 | 15,100 |

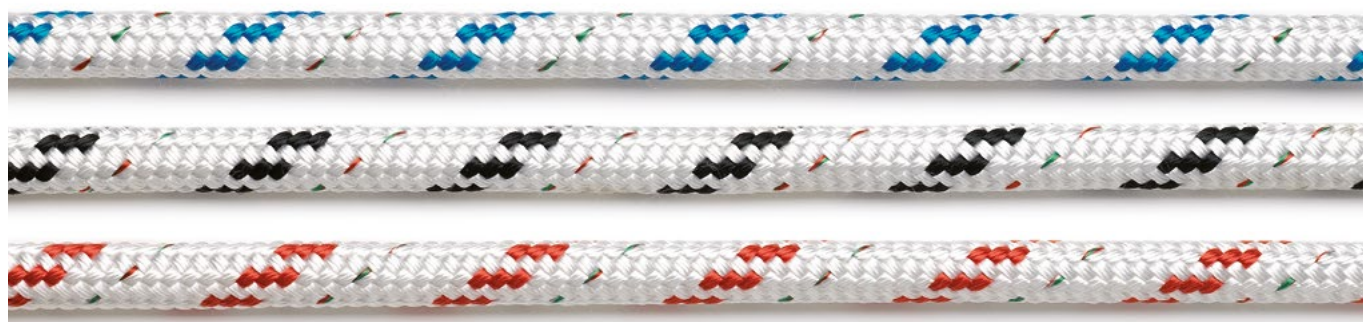

SCOTTA DA CROCIERA «SAIL» | «SAIL» SHEET

SAIL POLYESTER MT

Ideale per:
scotta Cruising per randa e genoa
Particolarità:
maneggevole e a basso allungamento

Anima:
16 fusi in poliestere alta tenacità

Calza:
16 fusi (Ø 5 - 6 - 8 - 10 - 12) 24 (Ø 14) in poliestere, media tenacità

Confezione:
in bobine

Suitable for:
Halyard for genoa and main sail

Features:
high tear resistance, low stretch, handy

Core:
16 plait in high tenacity Polyester

Cover:
16 plait (Ø 5 - 6 - 8 - 10 - 12) 24 (Ø 14) in Polyester, medium tenacity

Packing:
reels

| Articolo - Item | €/mt. | €/🌀 | Articolo - Item | €/mt. | €/🌀 | Articolo - Item | €/mt. | €/🌀 | Ø mm. | 🌀 mt. | ↓ kg. | 📦 kg. |
|-----------------|-------|-----|-----------------|-------|-----|-----------------|-------|-----|-------|-------|-------|--------|
| T 37 05 000 | | | T 36 05 000 | | | T 33 05 000 | | | 5 | 200 | 400 | 3,600 |
| T 37 06 000 | | | T 36 06 000 | | | T 33 06 000 | | | 6 | 200 | 600 | 4,920 |
| T 37 08 000 | | | T 36 08 000 | | | T 33 08 000 | | | 8 | 150 | 1200 | 7,140 |
| T 37 10 000 | | | T 36 10 000 | | | T 33 10 000 | | | 10 | 150 | 1600 | 11,550 |
| T 37 12 000 | | | T 36 12 000 | | | T 33 12 000 | | | 12 | 100 | 2000 | 10,200 |
| T 37 14 000 | | | T 36 14 000 | | | T 33 14 000 | | | 14 | 100 | 2600 | 15,000 |

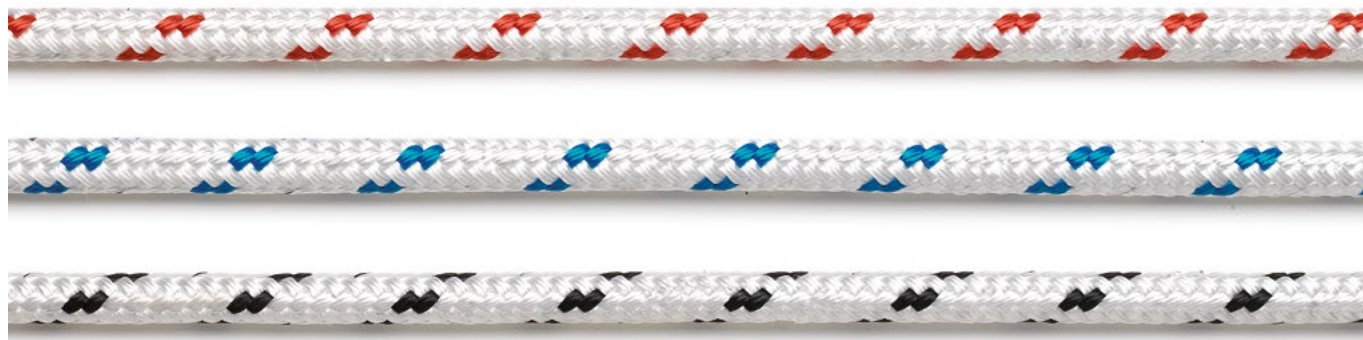

CIMA DA VELA | SAILING ROPE

Olympic ropes

01

SCOTTA DA CARICO ALTO/BASSO «PERTH» | «PERTH» GENOA SHEETS & HARD WORK ON WINCHES

PERTH POLYESTER HT madeby

Ideale per:

scotte, carico alto/basso

Particolarità:

buona resistenza all'allungamento, facilmente impiombabile

Anima:

16 fusi (Ø 6) 32 fusi (Ø 8 - 10) in poliestere alta tenacità

Calza:

24 fusi (Ø 6) 32 fusi (Ø 8 - 10) in poliestere, alta tenacità

Confezione:

in bobine

Suitable for:

halyard, high-low charge

Features:

high tear resistance, very low stretch

Core:

16 plait (Ø 6) 32 plait (Ø 8 - 10) in high tenacity Polyester

Cover:

24 plait (Ø 6) 32 (Ø 8 - 10) in Polyester, high tenacity

Packing:

reels

| Articolo - Item | €/mt. | €/🌀 | Articolo - Item | €/mt. | €/🌀 | Articolo - Item | €/mt. | €/🌀 | Ø mm. | 🌀 mt. | ⬆️ kg. | 📦 kg. |
|-----------------|-------|-----|-----------------|-------|-----|-----------------|-------|-----|-------|-------|--------|-------|
| F 69 06 082 | - | - | - | - | - | F 69 06 075 | - | - | 6 | 200 | 800 | 5,100 |
| - | - | - | F 69 08 077 | - | - | - | - | - | 8 | 150 | 1200 | 7,200 |



SCOTTA MULTISUO «TAMPA» | «TAMPA» MULTIPURPOSE SHEETS

TAMPA POLYESTER madeby

Ideale per:

multisuo

Particolarità:

maneggevole e a basso allungamento

Anima:

16 fusi in poliestere media tenacità

Calza:

16 fusi (Ø 3 - 4 - 5 - 6 - 8 - 10 - 12) in poliestere, alta tenacità

Confezione:

in bobine

Suitable for:

multipurpose

Features:

high tear resistance, very low stretch, handy

Core:

16 plait in medium tenacity Polyester

Cover:

16 plait (Ø 3 - 4 - 5 - 6 - 8 - 10 - 12) in Polyester, high tenacity

Packing:

reels

| Articolo - Item | €/mt. | €/🌀 | Articolo - Item | €/mt. | €/🌀 | Articolo - Item | €/mt. | €/🌀 | Ø mm. | 🌀 mt. | ⬆️ kg. | 📦 kg. |
|-----------------|-------|-----|-----------------|-------|-----|-----------------|-------|-----|-------|-------|--------|--------|
| T 10 03 074 | - | - | T 10 03 075 | - | - | - | - | - | 3 | 200 | 300 | 0,760 |
| T 10 04 074 | - | - | T 10 04 075 | - | - | T 10 04 080 | - | - | 4 | 200 | 380 | 1,840 |
| T 10 05 074 | - | - | T 10 05 075 | - | - | T 10 05 080 | - | - | 5 | 200 | 550 | 4,000 |
| T 10 06 074 | - | - | T 10 06 075 | - | - | T 10 06 080 | - | - | 6 | 200 | 750 | 4,920 |
| T 10 08 074 | - | - | T 10 08 075 | - | - | T 10 08 080 | - | - | 8 | 150 | 1200 | 7,170 |
| T 10 10 074 | - | - | T 10 10 075 | - | - | - | - | - | 10 | 150 | 1600 | 11,550 |
| T 10 12 074 | - | - | T 10 12 075 | - | - | - | - | - | 12 | 100 | 2000 | 10,200 |



CIMA DA VELA | SAILING ROPE

Olympic ropes

01

SCOTTA MULTISUO «KAT COLOR» | «KAT COLOR» MULTIPURPOSE SHEETS

KAT COLOR POLYESTER HT

Ideale per:
scotte generiche, avvolgi fiocchi
Particolarità:
molto maneggevole e morbida
Anima:
16 fusi in poliestere alta tenacità
Calza:
32 fusi
Confezione:
in bobine

Suitable for:
sheets and drum
Features:
very soft and handy
Core:
16 plait in high tenacity Polyester
Cover:
32 plait
Packing:
reels

| Articolo - Item | €/mt. | €/🌀 | Ø mm. | 🌀 mt. | ↓ kg. | 📦 kg. |
|-----------------|-------|-----|-------|-------|-------|-------|
| F 56 08 000 | | | 8 | 150 | 1300 | 6,975 |



TRECCIA PER PALAMITI E USI VARI «DURBAN» | «DURBAN» MULTIPURPOSE BRAIDED ROPE

DURBAN NYLON

Treccia in nylon colore bianco

Nylon braided rope white colour

Massima resistenza, minimo allungamento.

High resistance, very low stretch.

| Articolo - Item | €/mt. | €/🌀 | Ø mm. | ↓ kg. | 🌀 mt. | 📦 kg. |
|-----------------|-------|-----|-------|-------|-------|--------|
| T 38 15 000 | | | 1,5 | 65 | 500 | 0,700 |
| T 38 02 000 | | | 2 | 95 | 500 | 1,000 |
| T 38 25 000 | | | 2,5 | 180 | 500 | 1,900 |
| T 38 03 000 | | | 3 | 210 | 200 | 0,900 |
| T 38 04 000 | | | 4 | 350 | 200 | 1,900 |
| T 38 05 000 | | | 5 | 560 | 200 | 3,300 |
| T 38 06 000 | | | 6 | 800 | 200 | 4,700 |
| T 38 08 000 | | | 8 | 1300 | 150 | 8,300 |
| T 38 10 000 | | | 10 | 2100 | 150 | 11,109 |



CIMA DA VELA | SAILING ROPE

CIMA DA ORMEGGIO IN MATASSE | MOORING ROPE IN SPOOLS

POLYESTER made by **Cima di ormeggio ritorta
3 capi in poliestere colore
bianco con occhio**Speciale per ormeggio provvista ad una
estremità di cappio di 20 cm.**Polyester 3-strand spliced
rope white colour with eye**Mooring line with a spliced loop
diameter 20 cm.

| Articolo - Item | €/pc. | Ø mm. | mt. | kg. | kg. |
|-----------------|-------|-------|-----|-----|-------|
| T 50 08 008 | | 8 | 8 | 500 | 0,410 |
| T 50 10 011 | | 10 | 10 | 800 | 0,760 |

**POLYESTER** made by **Cima di ormeggio ritorta 3
capi in poliestere colore nero
non impiombata****Polyester 3-strand mooring
rope black colour not spliced**

| Articolo - Item | €/pc. | Ø mm. | mt. | kg. | kg. |
|-----------------|-------|-------|-----|------|-------|
| T 52 20 010 | | 20 | 10 | 3100 | 2,450 |
| T 52 20 012 | | 20 | 12 | 3100 | 2,600 |
| T 52 20 016 | | 20 | 16 | 3100 | 3,000 |

**POLYAMIDE****Cima di ormeggio doppia
treccia in Polyamide colore
nero con occhiello****PA braided mooring rope
black colour with spliced eye**

| Articolo - Item | €/pc. | Ø mm. | Length mt. | kg. |
|-----------------|-------|-------|------------|-------|
| T 42 10 006 | | 10 | 6 | 0,700 |
| T 42 12 006 | | 12 | 8 | 1,000 |

**NEW**

POLYESTER HT madeby 

Cima di ormeggio impiombata ad alta tenacità

In poliestere alta tenacità, a 3 capi.
Completa di randace inox e impiombatura fatta a mano.

Spliced mooring rope high tenacity

High tenacity 3-strand polyester mooring line.
With stainless steel thimble and hand-made splicing.

| Articolo - Item | €/pc. | kg. | Articolo - Item | €/pc. | Articolo - Item | €/pc. | Ø mm. | Length mt. | kg. | kg. |
|-----------------|-------|------|-----------------|-------|-----------------|-------|-------|------------|------|-------|
| T 50 12 209 | | 2000 | T 51 12 209 | | T 52 12 209 | | 12 | 9 | 1600 | 0,800 |
| T 50 14 212 | | 2700 | T 51 14 212 | | T 52 14 212 | | 14 | 12 | 2150 | 1,500 |
| T 50 16 212 | | 3600 | T 51 16 212 | | T 52 16 212 | | 16 | 12 | 3000 | 1,800 |
| - | | - | - | | T 52 20 212 | | 18 | 12 | 4200 | 3,2 |



MOOR LINE POLYESTER HT madeby 

Cima di ormeggio impiombata ad alta tenacità doppia treccia

In doppia treccia poliestere alta tenacità.
Completa di randace inox e impiombatura fatta a mano.

Double braided spliced mooring rope high tenacity

High tenacity double braided polyester mooring line.
With stainless steel thimble and hand-made splicing.

| Articolo - Item | €/pc. | Articolo - Item | €/pc. | Ø mm. | Length mt. | kg. | kg. |
|-----------------|-------|-----------------|-------|-------|------------|------|-------|
| F 46 12 207 | | F 47 12 207 | | 12 | 7 | 2600 | 0,800 |
| F 46 14 209 | | F 47 14 209 | | 14 | 9 | 3400 | 1,500 |
| F 46 16 211 | | F 47 16 211 | | 16 | 11 | 5000 | 2,000 |
| F 46 18 212 | | F 47 18 212 | | 18 | 12 | 5500 | 3,000 |
| F 46 20 213 | | F 47 20 213 | | 20 | 12 | 6500 | 3,200 |



MOOR LINE POLYESTER HT madeby 

Cima di ormeggio ad alta tenacità con occhio

In doppia treccia poliestere alta tenacità.
Con occhio impiombato a mano.

Spliced braided rope high tenacity with eye

High tenacity polyester double braided mooring line.
With hand-made spliced eye.

| Articolo - Item | €/pc. | Articolo - Item | €/pc. | Articolo - Item | €/pc. | Ø mm. | Length mt. | kg. | Anello-Ring Ø cm. |
|-----------------|-------|-----------------|-------|-----------------|-------|-------|------------|------|-------------------|
| F 45 12 007 | | F 47 12 007 | | F 46 12 007 | | 12 | 7 | 2600 | 20 |
| F 45 14 009 | | F 47 14 009 | | - | | 14 | 9 | 3400 | 20 |
| F 45 16 011 | | F 47 16 011 | | F 46 16 011 | | 16 | 11 | 5000 | 20 |
| F 45 18 012 | | F 47 18 012 | | F 46 18 012 | | 18 | 12 | 5500 | 20 |
| F 45 20 013 | | F 47 20 013 | | F 46 20 013 | | 20 | 13 | 6500 | 20 |

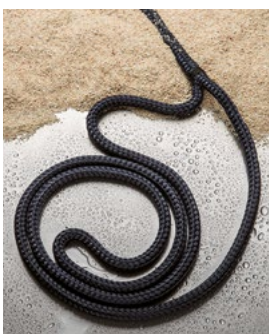

MOOR LINE POLYESTER HT madeby 

Doppia treccia colore nero «Moor Line»

Treccia in poliestere confezionata in bobina.

«Moor Line» double braided rope black colour

Polyester rope packed in reels.

| Articolo - Item | €/mt. | €/🌀 | Ø mm. | ↓ kg. | 🌀 mt. | 📦 kg. |
|-----------------|-------|-----|-------|-------|-------|--------|
| F 46 10 000 | | | 10 | 1.800 | 150 | 9,600 |
| F 46 12 000 | | | 12 | 2.600 | 100 | 9,350 |
| F 46 14 000 | | | 14 | 3.400 | 100 | 11,200 |
| F 46 16 000 | | | 16 | 4.200 | 100 | 14,600 |
| F 46 18 000 | | | 18 | 5.000 | 100 | 16,600 |
| F 46 20 000 | | | 20 | 6.500 | 100 | - |
| F 46 22 000 | | | 22 | 7.000 | 100 | - |
| F 46 24 000 | | | 24 | 7.900 | 100 | - |
| F 46 26 000 | | | 26 | 9.000 | 100 | - |



MOOR LINE POLYESTER HT madeby 

Doppia treccia colore blu Navy «Moor Line»

Treccia in poliestere confezionata in bobina.

«Moor Line» double braided rope Navy colour

Polyester rope packed in reels.

| Articolo - Item | €/mt. | €/🌀 | Ø mm. | ↓ kg. | 🌀 mt. | 📦 kg. |
|-----------------|-------|-----|-------|-------|-------|--------|
| F 47 10 000 | | | 10 | 1.800 | 150 | 9,600 |
| F 47 12 000 | | | 12 | 2.600 | 100 | 9,350 |
| F 47 14 000 | | | 14 | 3.400 | 100 | 11,200 |
| F 47 16 000 | | | 16 | 4.200 | 100 | 14,600 |
| F 47 18 000 | | | 18 | 5.000 | 100 | 16,600 |
| F 47 20 000 | | | 20 | 6.500 | 100 | - |
| F 47 22 000 | | | 22 | 7.000 | 100 | - |
| F 47 24 000 | | | 24 | 7.900 | 100 | - |
| F 47 26 000 | | | 26 | 9.000 | 100 | - |



CIMA DA ORMEGGIO RITORTA 3 CAPI 3-STRAND MOORING ROPE

POLIPROPYLENE madeby 

Cima in polipropilene ritorta 3 capi colore canapa

Resistente ai raggi del sole e con buona resistenza alla rottura.

3-strand Polypropylene hemp-type rope

UV resistant, good breaking load.

| Articolo - Item | €/mt. | €/🌀 | Ø mm. | ↓ kg. | 🌀 mt. | 📦 kg. |
|-----------------|-------|-----|-------|-------|-------|--------|
| T 51 12 078 | | | 12 | 1.200 | 100 | 11,000 |
| T 51 14 078 | | | 14 | 1.500 | 100 | 15,000 |
| T 51 16 078 | | | 16 | 2.200 | 100 | 18,000 |



CIMA DA ORMEGGIO 8 CAPI 8-STRAND MOORING ROPE

POLYESTER HT madeby 

Cima da ormeggio in poliestere trecciata a 8 capi «Square Line»

Non galleggiante.

Mooring rope in polyester 8 strand «Square Line»

Not floating.

| Articolo - Item | €/mt. | €/🌀 | Ø mm. | ↓ kg. | 🌀 mt. | 📦 kg. |
|-----------------|-------|-----|-------|-------|-------|----------|
| T 49 12 075 | | | 12 | 2.000 | 100 | * 10,800 |
| T 49 14 075 | | | 14 | 2.500 | 100 | * 11,200 |
| T 49 16 075 | | | 16 | 3.000 | 100 | * 14,600 |
| T 49 18 075 | | | 18 | 3.900 | 100 | * 16,600 |
| T 49 20 075 | | | 20 | 4.600 | 100 | * 25,000 |
| T 49 22 075 | | | 22 | 5.000 | 100 | * 31,000 |
| T 49 24 075 | | | 24 | 5.600 | 80 | * 38,000 |



POLYESTER HT madeby 

Cima in poliestere alta tenacità 3-strand high tenacity
ritorta 3 capi bianca Polyester white rope

Non galleggiante.

Not floating.

| Articolo - Item | €/mt. | €/kg | Ø mm. | kg. | mt. | kg. |
|-----------------|-------|------|-------|-------|-----|--------|
| T 50 06 000 | | | 6 | 500 | 200 | 7,600 |
| T 50 08 000 | | | 8 | 900 | 200 | 13,400 |
| T 50 10 000 | | | 10 | 1300 | 200 | 16,490 |
| T 50 12 000 | | | 12 | 1900 | 200 | 22,000 |
| T 50 14 000 | | | 14 | 2600 | 100 | 15,000 |
| T 50 16 000 | | | 16 | 3300 | 100 | 18,500 |
| T 50 18 000 | | | 18 | 4300 | 100 | 22,000 |
| T 50 20 000 | | | 20 | 5200 | 100 | 27,000 |
| T 50 22 000 | | | 22 | 5600 | 100 | 33,000 |
| T 50 24 000 | | | 24 | 6500 | 100 | 37,000 |
| T 50 26 000 | | | 26 | 7700 | 100 | 45,000 |
| T 50 28 000 | | | 28 | 8600 | 100 | 50,000 |
| T 50 30 000 | | | 30 | 9200 | 100 | 60,000 |
| T 50 32 000 | | | 32 | 10000 | 100 | 68,000 |



POLYESTER HT madeby 

Cima in poliestere alta tenacità 3-strand high tenacity
ritorta 3 capi nera Polyester black rope

Non galleggiante.

Not floating.

| Articolo - Item | €/mt. | €/kg | Ø mm. | kg. | mt. | kg. |
|-----------------|-------|------|-------|-------|-----|--------|
| T 52 08 000 | | | 8 | 900 | 200 | 13,400 |
| T 52 10 000 | | | 10 | 1300 | 200 | 16,490 |
| T 52 12 000 | | | 12 | 1900 | 200 | 22,000 |
| T 52 14 000 | | | 14 | 2600 | 100 | 15,000 |
| T 52 16 000 | | | 16 | 3300 | 100 | 18,500 |
| T 52 18 000 | | | 18 | 4300 | 100 | 22,000 |
| T 52 20 000 | | | 20 | 5200 | 100 | 27,000 |
| T 52 22 000 | | | 22 | 5600 | 100 | 33,000 |
| T 52 24 000 | | | 24 | 6500 | 100 | 37,000 |
| T 52 26 000 | | | 26 | 7700 | 100 | 45,000 |
| T 52 28 000 | | | 28 | 8600 | 100 | 50,000 |
| T 52 30 000 | | | 30 | 9200 | 100 | 60,000 |
| T 52 32 000 | | | 32 | 10000 | 100 | 68,000 |



POLYESTER HT madeby 

Cima in poliestere alta tenacità 3-strand high tenacity
ritorta 3 capi grigia Polyester grey rope

Non galleggiante.

Not floating.

| Articolo - Item | €/mt. | €/kg | Ø mm. | kg. | mt. | kg. |
|------------------------|-------|------|-------|------|-----|--------|
| T 51 10 000 | | | 10 | 1000 | 200 | 16,490 |
| T 51 12 000 | | | 12 | 1660 | 200 | 22,000 |
| T 51 14 000 | | | 14 | 2280 | 100 | 15,000 |
| T 51 16 000 | | | 16 | 2890 | 100 | 18,500 |
| T 51 18 000 | | | 18 | 3760 | 100 | 22,000 |
| T 51 20 000 | | | 20 | 4200 | 100 | 27,000 |
| T 51 22 000 NEW | | | 22 | 5000 | 100 | 33,000 |
| T 51 24 000 | | | 24 | 6000 | 100 | 37,000 |



POLYESTER HT madeby 

Cima in poliestere alta tenacità 3-strand high tenacity
ritorta 3 capi blu Polyester blue rope

Non galleggiante.

Not floating.

| Articolo - Item | €/mt. | €/kg | Ø mm. | kg. | mt. | kg. |
|-----------------|-------|------|-------|------|-----|--------|
| T 51 06 075 | | | 6 | 440 | 200 | 16,490 |
| T 51 08 075 | | | 8 | 780 | 200 | 22,000 |
| T 51 10 075 | | | 10 | 1140 | 200 | 15,000 |
| T 51 12 075 | | | 12 | 1660 | 200 | 18,500 |
| T 51 14 075 | | | 14 | 2280 | 100 | 22,000 |
| T 51 16 075 | | | 16 | 2890 | 100 | 27,000 |
| T 51 18 075 | | | 18 | 3760 | 100 | 22,000 |
| T 51 20 075 | | | 20 | 4200 | 100 | 27,000 |
| T 51 22 075 | | | 22 | 4700 | 100 | 33,000 |
| T 51 24 075 | | | 24 | 5500 | 100 | 37,000 |
| T 51 26 075 | | | 26 | 6740 | 100 | 45,000 |
| T 51 28 075 | | | 28 | 7000 | 100 | 50,000 |



VISITA IL NOSTRO
NUOVO WEBSITE



WWW.TREM.NET





POLYESTER MT madeby 

Cima «Regolamentare» per ancora trecciata in poliestere

Braided anchor line in polyester

| Articolo - Item | €/pc. | Ø mm. | mt. | kg. |
|-----------------|-------|-------|-----|-------|
| T 87 08 030 | | 8 | 30 | 0,780 |
| T 87 10 030 | | 10 | 30 | 1,350 |
| T 87 10 050 | | 10 | 50 | 2,150 |



POLYESTER HT madeby 

Cima «Regolamentare» per ancora trecciata in poliestere alta tenacità con redance impiombata

Braided anchor line in polyester High tenacity with spliced plastic thimble

| Articolo - Item | €/pc. | Ø mm. | mt. | kg. |
|-----------------|-------|-------|-----|-------|
| T 01 06 030 | | 6 | 30 | 0,770 |
| T 01 08 030 | | 8 | 30 | 1,200 |
| T 01 10 030 | | 10 | 30 | 1,430 |



POLYESTER HT madeby 

Cima per ancora in poliestere alta tenacità impiombata senza redance

Anchor line in polyester High tenacity without thimble

| Articolo - Item | €/pc. | Ø mm. | mt. | kg. |
|-----------------|-------|-------|-----|-------|
| T 47 08 030 | | 8 | 30 | 1,300 |



POLYESTER HT madeby 

Cima per ancora in poliestere alta tenacità senza impiombatura

Anchor line in polyester High tenacity not spliced

| Articolo - Item | €/pc. | Ø mm. | mt. | kg. |
|-----------------|-------|-------|-----|-------|
| T 48 08 030 | | 8 | 30 | 1,300 |
| T 48 10 030 | | 10 | 30 | 1,500 |



POLYESTER HT madeby 

Cima per ancora in poliestere alta tenacità completa di catena e di grillo zincato

Anchor line in polyester High tenacity complete with chain and galvanised shackle

Set completo per l'ancoraggio.

Mooring equipment.

| Articolo - Item | €/pc. | Ø mm. | mt. | Catena-Chain mt. | kg. |
|-----------------|-------|-------|-----|------------------|-------|
| T 01 08 031 | | 8 | 30 | 1,50 | 1,300 |
| T 01 10 031 | | 10 | 30 | 2,00 | 1,500 |



POLYESTER made by 

Cima per ancora trecciata in poliestere

Double braided polyester rope for anchor

Confezione in bobine.
Vendita a bobine.

Packing on reels.
Sales on reel.

| Articolo - Item | €/mt. | Articolo - Item | €/mt. | Ø mm. | kg. | mt. | kg. |
|-----------------|-------|-----------------|-------|-------|-----|-----|--------|
| T 09 05 180 R | | T 09 05 001 R | | 5 | 100 | 500 | 7,600 |
| T 09 06 180 R | | T 09 06 001 R | | 6 | 120 | 400 | 8,900 |
| T 09 08 180 R | | T 09 08 001 R | | 8 | 200 | 400 | 15,150 |
| T 09 10 180 R | | T 09 10 001 R | | 10 | 260 | 200 | 11,000 |
| T 09 12 180 R | | T 09 12 001 R | | 12 | 340 | 200 | 15,600 |
| T 09 14 180 R | | T 09 14 001 R | | 14 | 400 | 200 | 22,000 |
| T 09 16 180 R | | T 09 16 001 R | | 16 | 460 | 170 | 24,200 |



SAIPAM POLYESTER made by 

Cima per ancora trecciata in poliestere colore bianco filo segnale blu

Double braided polyester rope for anchor white colour blue tracer thread

Fabbricata in multifilamenti di poliestere 16 e 24 fusi.
Buona resistenza. Non galleggiante.
Confezione in bobine.

Polyester multifilament braided line 16 & 24 fuses.
Not floating.
Packing on reels.

| Articolo - Item | €/mt. | €/mt. | Ø mm. | kg. | mt. | kg. |
|-----------------|-------|-------|-------|------|-----|--------|
| T 10 04 010 | | | 4 | 350 | 200 | 1,860 |
| T 10 06 010 | | | 6 | 600 | 200 | 4,900 |
| T 10 08 010 | | | 8 | 900 | 150 | 7,050 |
| T 10 10 010 | | | 10 | 1500 | 150 | 11,550 |



CIMA CON PIOMBO | ROPE WITH LEAD CORE

POLYESTER

Cima recupero corpi morti in poliestere con anima in piombo

Polyester rope with lead core

Realizzata in calza di poliestere, con anima interna in polipropilene più rosario in piombo.
Confezione in bobine.

Polyester sheath, inner core made of polypropylene and a soul of lead.
Packing on reels.

| Articolo - Item | €/mt. | €/mt. | Ø mm. | Colore Colour | mt. | kg. |
|-----------------|-------|-------|-------|---------------|-----|--------|
| T 57 08 074 | | | 8 | | 100 | 10,600 |



CIMA PER PARABORDI | FENDER ROPES

POLYESTER

made by 

Treccia piattina in poliestere per fissaggio parabordi

Studiata appositamente per il fissaggio dei parabordi. Fabbricata senza anime e facile da impiombare.

Polyester flat line for fenders

Manufactured without core, easy splicing.



| Articolo - Item | €/mt. | €/🌀 | Articolo - Item | €/mt. | €/🌀 | Articolo - Item | €/mt. | €/🌀 | Articolo - Item | €/mt. | €/🌀 | Ø mm. | Piattina mm. | 🌀 mt. |
|-----------------|-------|-----|-----------------|-------|-----|-----------------|-------|-----|-----------------|-------|-----|-------|--------------|-------|
| - | - | - | - | - | - | T 16 18 075 | - | - | T 16 18 080 | - | - | 10 | 3,3x18 | 200 |
| T 16 20 062 | - | - | T 16 20 074 | - | - | T 16 20 075 | - | - | T 16 20 080 | - | - | 14 | 4,5x20 | 200 |



POLYESTER

made by 

Cima in poliestere alta tenacità per fissaggio parabordi con occhiello

Doppia treccia poliestere con occhio impiombato a mano.

High tenacity polyester spliced eye fender line

Double braided polyester line with hand-made spliced eye.



| Articolo - Item | Articolo - Item | Articolo - Item | €/pc. | Ø mm. | 🌀 mt. | 📦 kg. |
|------------------------|------------------------|------------------------|-------|-------|-------|-------|
| T 86 06 174 NEW | T 86 06 175 NEW | T 86 06 180 NEW | - | 6 | 1,5 | 0,08 |
| T 86 08 174 | T 86 08 175 | T 86 08 180 | - | 8 | 1,5 | 0,10 |
| T 86 10 274 | T 86 10 275 | T 86 10 280 | - | 10 | 2 | 0,20 |
| T 86 12 274 | T 86 12 275 | T 86 12 280 | - | 12 | 2,5 | 0,25 |

TRECCIA AVVIAMENTO MOTORI
ROPE TO START OUTBOARD MOTOR

NYLON

made by 

Treccia per avviamento motori fuoribordo in nylon bianco «Trem Starter»

Special spare rope to start outboard motor in white nylon «Trem Starter»

| Articolo - Item | €/mt. | €/🌀 | Ø mm. | 🌀 mt. | 📦 kg. | 📦 kg. |
|-----------------|-------|-----|-------|-------|-------|-------|
| T 04 03 000 | - | - | 3,5 | 100 | 350 | 0,900 |
| T 04 04 000 | - | - | 4 | 100 | 450 | 1,150 |
| T 04 05 000 | - | - | 5 | 100 | 550 | 1,800 |

TRECCIA FUCILI SUBACQUEI
ROPE FOR SUBMARINE GUNS

POLIPROPILENE

made by 

Treccia di ricambio per fucili subacquei in polipropilene nero

Spare rope for submarine guns in black polypropylene

| Articolo - Item | €/mt. | €/🌀 | Ø mm. | 🌀 mt. | 📦 kg. |
|-----------------|-------|-----|-------|-------|-------|
| T 06 15 000 | - | - | 1,5 | 400 | 0,480 |
| T 06 02 000 | - | - | 2 | 400 | 0,720 |
| T 06 25 000 | - | - | 2,5 | 400 | 1,400 |
| T 06 03 000 | - | - | 3 | 200 | 0,800 |
| T 06 04 000 | - | - | 4 | 200 | 1,300 |



POLYESTER HT made by  *Olimpic*

Bobinette di treccina in poliestere alta tenacità con filo segnale «Ibiza» **Braided rope high tenacity polyester packaging in «self-service» reels**

Ideale per mille usi.

Multipurpose use.

| Articolo - Item | Articolo - Item | Articolo - Item | Articolo - Item | €/mt. | Ø mm. | mt. |
|-----------------|-----------------|-----------------|-----------------|-------|-------|-----|
| T 76 25 022 | - | T 78 25 022 | T 82 25 022 | | 2,5 | 22 |
| T 76 03 020 | T 75 03 020 | T 78 03 020 | - | | 3 | 20 |
| T 76 04 013 | T 75 04 013 | - | T 82 04 013 | | 4 | 13 |



POLYESTER HT made by  *Olimpic*

Treccina in poliestere con filo segnale «Ibiza» **«Ibiza Multicolor» polyester braided rope**

In bobine da 200 mt.

Reels 200 mt.

| Articolo - Item | Articolo - Item | Articolo - Item | Articolo - Item | €/mt. | €/mt. | Ø mm. | mt. |
|-----------------|-----------------|-----------------|-----------------|-------|-------|-------|-----|
| T 76 03 000 | T 75 03 000 | T 78 03 000 | T 82 03 000 | | | 3 | 200 |
| T 76 04 000 | T 75 04 000 | T 78 04 000 | T 82 04 000 | | | 4 | 200 |



POLYESTER HT made by  *Olimpic*

Espositore da tavolo completo di 24 bobine assortite in diametri e colori **Bank rack complete with 24 reels in assorted colours and diameters**

| Articolo - Item | €/pc. | Modello - Model |
|-----------------|-------|--------------------|
| T 75 00 000 | | «Ibiza Multicolor» |

Espositore completo di 24 bobine - Rack complete with 24 reels



POLYESTER HT made by  *Olimpic*

Bobinette di treccina in poliestere alta tenacità monocolore **Braided rope high tenacity polyester packaging in «self-service» reels**

Ideale per mille usi.

Multipurpose use.

| Articolo - Item | Articolo - Item | Articolo - Item | Articolo - Item | Articolo - Item | €/mt. | €/mt. | Ø mm. | mt. |
|-----------------|-----------------|-----------------|-----------------|-----------------|-------|-------|-------|-----|
| T 38 02 030 | - | T 95 02 030 | T 94 02 030 | - | | | 2 | 30 |
| T 38 03 020 | T 96 03 020 | T 95 03 020 | T 94 03 020 | T 97 03 020 | | | 3 | 20 |



POLYESTER HT made by  *Olimpic*

Treccina in poliestere monocolore «Ibiza Color» **«Ibiza Multicolor» polyester braided rope**

In bobine da 200 mt.

Packing in reels of 200 mt.

| Articolo - Item | Articolo - Item | Articolo - Item | Articolo - Item | Articolo - Item | €/mt. | €/mt. | Ø mm. | mt. |
|-----------------|-----------------|-----------------|-----------------|-----------------|-------|-------|-------|-----|
| T 38 02 200 | T 94 02 000 | T 95 02 000 | T 96 02 000 | T 97 02 000 | | | 2 | 200 |
| T 38 03 200 | T 94 03 000 | T 95 03 000 | T 96 03 000 | T 97 03 000 | | | 3 | 200 |



POLYESTER HT made by  *Olimpic*

Espositore da tavolo completo di 24 bobine assortite in diametri e colori **Bank rack complete with 24 reels in assorted colours and diameters**

| Articolo - Item | €/pc. | Modello - Model |
|-----------------|-------|-----------------|
| T 15 00 000 | | «Ibiza Color» |

Espositore completo di 24 bobine - Rack complete with 24 reels





POLYESTER made by

Filo per cucire vele e impiombature

Sewing thread for sail and splicing

100% Poliestere.

100% Polyester.

| Articolo - Item | €/mt. | mt. | Articolo - Item | Articolo - Item | €/mt. | Ø mm. | mt. |
|-----------------|-------|-----|-----------------|-----------------|-------|-------|-----|
| F 23 05 100 | | 100 | - | - | | 0,5 | - |
| F 23 01 050 | | 50 | F 23 80 100 | F 23 75 100 | | 1,0 | 100 |
| F 23 15 035 | | 35 | - | - | | 1,5 | - |

POLIPROPYLENE made by

Doppia treccia in polipropilene stabilizzato «Special Trem»

«Special Trem» double braided rope made of stabilized polypropylene



| Articolo - Item | €/mt. | €/mt. | Articolo - Item | Articolo - Item | Articolo - Item | Articolo - Item | €/mt. | €/mt. | Ø mm. | kg. | mt. |
|-----------------|-------|-------|-----------------|-----------------|-----------------|-----------------|-------|-------|-------|------|-----|
| T 10 04 000 | - | | - | - | T 26 04 000 | - | | | 4 | 150 | 200 |
| T 10 05 000 | | | T 27 05 000 | - | - | - | | | 5 | 200 | 200 |
| T 10 06 000 | | | T 27 06 000 | T 25 06 000 | T 26 06 000 | T 17 06 000 | | | 6 | 350 | 200 |
| T 10 08 000 | | | T 27 08 000 | T 25 08 000 | T 26 08 000 | T 17 08 000 | | | 8 | 500 | 150 |
| T 10 10 000 | | | T 27 10 000 | T 25 10 000 | T 26 10 000 | T 17 10 000 | | | 10 | 850 | 150 |
| T 10 12 000 | | | - | T 25 12 000 | T 26 12 000 | T 17 12 000 | | | 12 | 1100 | 100 |

NYLON made by

Treccia in nylon colore bianco trecciata ad aghi

White colour nylon rope needle braiding



| Articolo - Item | €/mt. | €/mt. | Ø mm. | mt. | kg. | kg. |
|-----------------|-------|-------|-------|-----|-----|-------|
| T 69 04 000 | | | 4 | 400 | 130 | 2,880 |
| T 69 05 000 | | | 5 | 400 | 290 | 5,000 |

POLYESTER made by

Treccia in poliestere colore bianco in confezione «Self-service»

White colour polyester rope Self-service packing



| Articolo - Item | €/mt. | Ø mm. | mt. | kg. |
|-----------------|-------|-------|-----|-------|
| T 39 02 050 | | 2 | 50 | 0,110 |
| T 39 03 050 | | 3 | 50 | 0,275 |
| T 39 04 040 | | 4 | 40 | 0,368 |
| T 39 05 030 | | 5 | 30 | 0,600 |



POLIPROPYLENE made by

Treccia in polipropilene bianco confezione «self-service»

White polypropylene braided rope Self-service packing





| Articolo - Item | €/mt. | Ø mm. | mt. | kg. |
|-----------------|-------|-------|-----|-------|
| T 10 04 020 | | 4 | 20 | 0,119 |



LEVILENE made by 

Treccia galleggiante «Trem Giava» senza anima per traino sci Floating water ski braided line w/out core

Monofilo fluorescente Ø 7,5 mm. trecciato 16 fusi. Fluorescent monofil Ø 7,5 mm. 16-plait.

| Articolo - Item | €/mt. | €/m | Colore Colour | Ø mm. | mt. | kg. | kg. |
|-----------------|-------|-----|---|-------|-----|------|-----|
| T 60 75 000 | | |  | 200 | 270 | 3,15 | |
| T 61 75 000 | | |  | 200 | 270 | 3,15 | |
| T 62 75 000 | | |  | 200 | 270 | 3,15 | |



LEVILENE made by 

Treccia galleggiante «Trem Fox» senza anima Floating braided rope «Trem Fox» w/out core

Monofilo bianco-blu-Rosso trecciato 16 fusi. White-Blue-Red monofil Ø 7,5 mm. 16-plait.

| Articolo - Item | €/mt. | €/m | Ø mm. | mt. | kg. | kg. |
|-----------------|-------|-----|-------|-----|-----|------|
| T 23 08 010 | | | 8 | 200 | 300 | 4,20 |



LEVILENE made by 

Treccia galleggiante «Trem Palau» senza anima «Trem Palau» floating braided rope w/out core

Monofilo giallo con filo segnale Rosso trecciato 16 fusi. Yellow monofil red threads 16-plait.

| Articolo - Item | €/mt. | €/m | Ø mm. | mt. | kg. | kg. |
|-----------------|-------|-----|-------|-----|-----|------|
| T 19 06 000 | | | 6 | 200 | 180 | 2,20 |
| T 19 08 000 | | | 8 | 200 | 300 | 4,10 |



LEVILENE made by 

Treccia galleggiante senza anima Floating knitted rope w/out core

Monofilo arancio trecciato ad aghi. Fabbricata in monofilo. Ideale per cime da lancio. Orange colour monofil. Suitable as throwing line.

| Articolo - Item | €/mt. | €/m | Ø mm. | mt. | kg. | kg. |
|-----------------|-------|-----|-------|-----|-----|------|
| T 90 04 000 | | | 4 | 400 | 40 | 2,00 |
| T 90 06 000 | | | 6 | 400 | 90 | 4,15 |



LEVILENE made by 

Treccia galleggiante «Trem Fria» senza anima «Trem Fria» floating braided rope w/out core

Monofilo arancio trecciato 16 fusi. Corda trecciata senza anima indicata per impiombature. Orange colour monofil. 16-plait. Suitable for splicing.

| Articolo - Item | €/mt. | €/m | Ø mm. | mt. | kg. | kg. |
|-----------------|-------|-----|-------|-----|-----|------|
| T 11 06 000 | | | 6 | 200 | 200 | 2,15 |
| T 11 08 000 | | | 8 | 200 | 400 | 4,05 |
| T 11 10 000 | | | 10 | 200 | 450 | 6,25 |
| T 11 12 000 | | | 12 | 100 | 600 | 4,35 |
| T 11 14 000 | | | 14 | 100 | 700 | 5,25 |
| T 11 08 300 | | | 8 | 300 | 400 | 6,05 |



LEVILENE made by 

Treccia galleggiante «Trem Azores» senza anima «Trem Azores» floating braided rope w/out core

Monofilo bianco trecciato 16 fusi. Corda trecciata senza anima indicata per impiombature. White colour monofil. 16-plait. Suitable for splicing.

| Articolo - Item | €/mt. | €/m | Ø mm. | mt. | kg. | kg. |
|-----------------|-------|-----|-------|-----|-----|------|
| T 24 10 000 | | | 10 | 150 | 450 | 4,65 |
| T 24 16 000 | | | 16 | 100 | 800 | 7,00 |



LEVILENE made by 

Treccia galleggiante «Trem Cook» senza anima «Trem Cook» floating braided rope w/out core

Monofilo nero trecciato 16 fusi. Per tientibene dei canotti pneumatici. Black colour monofil. 16-plait. For hand-rail of inflatable boats.

| Articolo - Item | €/mt. | €/m | Ø mm. | mt. | kg. | kg. |
|-----------------|-------|-----|-------|-----|-----|------|
| T 22 12 000 | | | 12 | 100 | 600 | 4,15 |
| T 22 14 000 | | | 14 | 100 | 700 | 5,00 |
| T 22 16 000 | | | 16 | 100 | 800 | 7,00 |



LEVILENE made by 

Treccia galleggiante «Haiti» senza anima «Haiti» floating braided rope w/out core

Monofilo grigio trecciato 16 fusi. Per tientibene dei canotti pneumatici. Grey colour monofil. 16-plait. For hand-rail of inflatable boats.

| Articolo - Item | €/mt. | €/m | Ø mm. | mt. | kg. | kg. |
|-----------------|-------|-----|-------|-----|-----|------|
| T 29 12 000 | | | 12 | 100 | 600 | 4,45 |
| T 29 14 000 | | | 14 | 100 | 700 | 5,40 |



LEVILENE made by 

Treccia galleggiante «Trem Haiti» senza anima «Trem Haiti» floating braided rope

Monofilo trecciato 16 fusi. Monofil. 16-plait.

| Articolo - Item | €/mt. | €/m | Ø mm. | mt. | kg. | kg. |
|-----------------|-------|-----|-------|-----|-----|------|
| T 24 12 075 | | | 12 | 100 | 600 | 4,45 |
| T 24 14 075 | | | 14 | 100 | 700 | 5,40 |



POLYESTER HT made by 

Corda elastica colore bianco filo segnale blu navy «Marina» bobine da 100 mt.

«Marina» special shock cord white colour Navy blue threads reels of 100 mt.

Corda elastica composta all'interno di lattice di gomma e ricoperta all'esterno di multifilamenti di poliestere.

Rubber core covered with polyester multifilament.

| Articolo - Item | €/mt. | €/  | Ø mm. | mt. | kg. |
|-----------------|-------|--|-------|-----|-------|
| C 10 03 000 | | | 3 | 100 | 0,800 |
| C 10 04 000 | | | 4 | 100 | 1,000 |
| C 10 05 000 | | | 5 | 100 | 2,000 |
| C 10 06 000 | | | 6 | 100 | 2,700 |
| C 10 08 000 | | | 8 | 100 | 4,600 |
| C 10 10 000 | | | 10 | 100 | 7,300 |



POLYESTER HT made by 

Corda elastica colore bianco filo segnale blu navy «Marina» bobine da 50 mt.

«Marina» special shock cord white colour Navy blue threads reels of 50 mt.

Corda elastica composta all'interno di lattice di gomma e ricoperta all'esterno di multifilamenti di poliestere.

Rubber core covered with polyester multifilament.

| Articolo - Item | €/mt. | €/  | Ø mm. | mt. | kg. |
|-----------------|-------|--|-------|-----|-------|
| C 10 04 050 | | | 4 | 50 | 0,500 |
| C 10 05 050 | | | 5 | 50 | 1,000 |
| C 10 06 050 | | | 6 | 50 | 1,350 |
| C 10 08 050 | | | 8 | 50 | 2,300 |
| C 10 10 050 | | | 10 | 50 | 3,650 |
| C 10 12 050 | | | 12 | 50 | 5,000 |
| C 10 14 050 | | | 14 | 50 | 7,000 |



POLYESTER HT made by 

Corda elastica bianca

White shock cord

| Articolo - Item | €/mt. | €/  | Ø mm. | mt. | kg. |
|-----------------|-------|--|-------|-----|-------|
| C 10 04 000 W | | | 4 | 100 | 0,500 |
| C 10 05 000 W | | | 5 | 100 | 1,000 |
| C 10 06 000 W | | | 6 | 100 | 1,350 |
| C 10 08 000 W | | | 8 | 100 | 2,300 |



POLYESTER HT made by 

Corda elastica bianca confezione «Self-service» da 20 m.

Shock cord white colour «Self-service» packing 20 m.

| Articolo - Item | €/mt. | Colore-Colour | Ø mm. | mt. | kg. |
|-----------------|-------|----------------------|-------|-----|-------|
| C 21 03 020 | | <input type="text"/> | 3 | 20 | 0,160 |



POLYESTER HT made by 

Corda elastica «Color»

«Color» shock cord

Corda elastica composta all'interno di lattice di gomma e ricoperta all'esterno di multifilamenti di poliestere.

Rubber core covered with polyester multifilament.

| Articolo - Item | Articolo - Item | Articolo - Item | €/mt. | €/  | Ø mm. | mt. | kg. |
|-----------------|-----------------|-----------------|-------|--|-------|-----|-------|
| C 77 05 000 | C 78 05 000 | C 75 05 000 | | | 5 | 100 | 2,000 |
| C 77 06 000 | C 78 06 000 | C 75 06 000 | | | 6 | 100 | 3,000 |

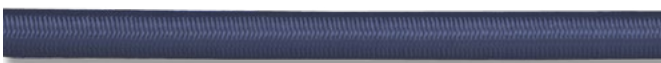

POLYESTER HT made by 

Corda elastica nera

Black shock cord

Corda elastica composta all'interno di lattice di gomma e ricoperta all'esterno di multifilamenti di poliestere.

Rubber core covered with polyester multifilament.

| Articolo - Item | €/mt. | €/  | Ø mm. | mt. | kg. |
|-----------------|-------|--|-------|-----|-------|
| C 80 03 000 | | | 3 | 100 | 0,800 |
| C 80 04 000 | | | 4 | 100 | 1,000 |
| C 80 05 000 | | | 5 | 100 | 2,000 |
| C 80 06 000 | | | 6 | 100 | 3,000 |
| C 80 08 000 | | | 8 | 100 | 4,500 |



Elastici Millepiedi per vele mod. «Regata»

Con cavigliotti in nylon e ganci inox muniti di arresto.

Elastic millipede set for mast «Regata»

Supplied with nylon toggles and steel hooks with stops.

| Articolo - Item | €/pc. | Ø mm. | Length cm. | kg. |
|-----------------|-------|-------|------------|-------|
| C 05 08 200 | | 8 | 200 | 0,260 |
| C 05 08 300 | | 8 | 300 | 0,325 |
| C 05 10 300 | | 10 | 300 | 0,410 |



Elastici serravele con palline bicolore mod. «Extra»

Elastic sail fasteners with plastic balls

| Articolo - Item | €/ box 4 pc. | Ø mm. | Length cm. | kg. |
|-----------------|--------------|-------|------------|-------|
| C 03 04 030 | | 4 | 30 | 0,080 |
| C 03 04 040 | | 4 | 40 | 0,100 |
| C 03 04 050 | | 4 | 50 | 0,120 |
| C 03 04 060 | | 4 | 60 | 0,140 |



Elastici serravele e fermaremi elastici «Standard»

Elastic sail fasteners with nylon hooks

| Articolo - Item | €/ box 4 pc. | Colore Colour | Ø mm. | Length cm. | kg. |
|-----------------|--------------|---------------|-------|------------|-------|
| C 04 04 020 | | | 4 | 20 | 0,090 |
| C 04 04 035 | | | 4 | 35 | 0,120 |
| C 04 04 055 | | | 4 | 55 | 0,150 |
| C 04 80 028 | | | 4 | 28 | 0,110 |



Elastici serravele regolabili con chiusura «Olive-Clip»

Adjustable elastic «Olive-Clip» sail fasteners

| Articolo - Item | €/ box 4 pc. | Ø mm. | Length cm. | kg. |
|-----------------|--------------|-------|------------|-------|
| C 07 05 055 | | 5 | 55 | 0,070 |
| C 07 06 075 | | 6 | 75 | 0,170 |
| C 07 08 080 | | 8 | 80 | 0,220 |

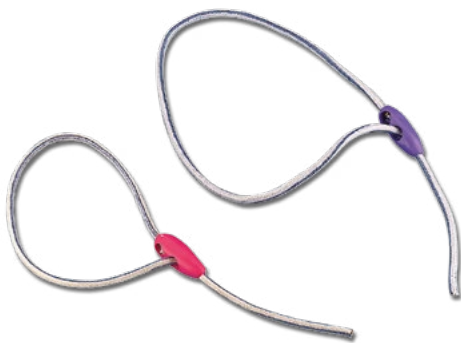

Elastici con ganci in nylon

Elastic cords with nylon hooks

| Articolo - Item | €/ box 4 pc. | Ø mm. | Length cm. | kg. |
|-----------------|--------------|-------|------------|-------|
| C 00 04 020 | | 4 | 20 | 0,040 |
| C 00 04 030 | | 4 | 30 | 0,060 |
| C 00 06 030 | | 6 | 30 | 0,080 |
| C 00 08 050 | | 8 | 50 | 0,210 |
| C 00 10 100 | | 10 | 100 | 0,500 |

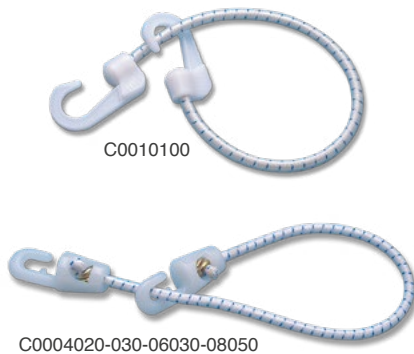

Elastici serravele con cavigliotti in nylon

Elastic sail fasteners with nylon toggles

| Articolo - Item | €/ box 4 pc. | Colore Colour | Ø mm. | Length cm. | kg. |
|-----------------|--------------|---------------|-------|------------|------|
| C 02 06 035 | | | 6 | 35 | 0,08 |
| C 02 06 055 | | | 6 | 55 | 0,10 |



Elastici milleusi colori assortiti provvisti di ganci in nylon

Elastic rubber straps with nylon hooks assorted colors

| Articolo - Item | €/ box 10 pc. | Ø mm. | Length cm. | kg. |
|-----------------|---------------|-------|------------|-------|
| A 31 08 060 | | 8 | 60 | 0,130 |
| A 31 08 100 | | 8 | 100 | 0,150 |

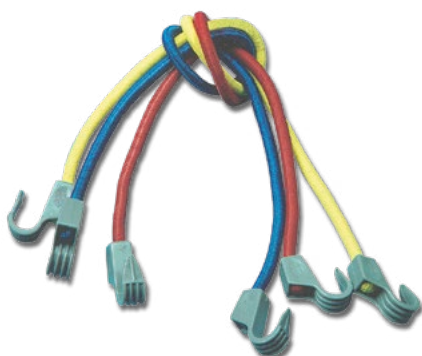

Elastici con ganci inox

Shock-cords with s.s. hooks

| Articolo - Item | €/ box 4 pc. | Ø mm. | Length cm. | kg. |
|-----------------|--------------|-------|------------|-------|
| C 06 06 030 | | 6 | 30 | 0,120 |
| C 06 08 050 | | 8 | 50 | 0,300 |
| C 06 08 075 | | 8 | 75 | 0,400 |
| C 06 10 060 | | 10 | 60 | 0,450 |
| C 06 10 075 | | 10 | 75 | 0,500 |
| C 06 10 100 | | 10 | 100 | 0,600 |
| C 06 10 150 | | 10 | 150 | 0,800 |



Espositore corda elastica e ganci milleusi

Small shop display for elastic cord and hooks

| Articolo - Item | €/pc. |
|-----------------|-------|
| C 11 00 000 | |

Completo di Complete with:

| Articolo - Item | Quantità - Qty | Ø mm. |
|-----------------|----------------|-------|
| C 10 04 000 | 100 mt. | 4 |
| C 10 06 000 | 100 mt. | 6 |
| C 10 08 000 | 100 mt. | 8 |
| C 10 10 050 | 50 mt. | 10 |

Assortiti 100 ganci - hooks
 C 25 06 010 50 utility clips 6
 C 25 08 012 50 utility clips 8
 C 25 05 015 50 fissaggio olive clips 4-5
 Altezza-Height 75 cm. - Larghezza-Width 25 cm. - Peso-Weight 15 Kg.



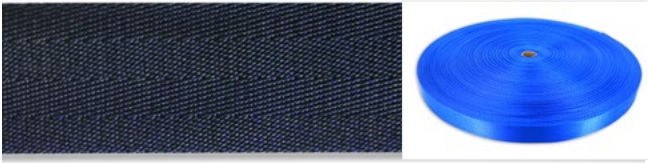

POLIPROPYLENE

Cinghie Blue

Cinghie in Polipropilene Blue per uso nautico. Vendute a rotolo.

Blue belts

Polipropylene belts for boating. Roll packing.

| Articolo - Item | €/mt. | €/m ² | H mm. | Length mt. | kg. |
|-----------------|-------|------------------|-------|------------|-------|
| N 05 30 075 | | | 30 | 100 | 3,350 |
| N 05 50 075 | | | 50 | 100 | 5,500 |

madeby

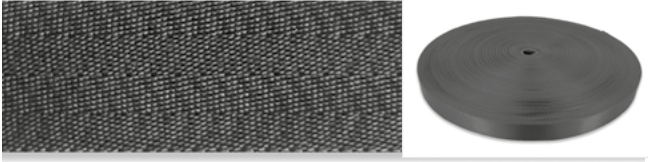

POLIPROPYLENE

Cinghie Nere

Cinghie in Polipropilene Nero per uso nautico. Vendute a rotolo.

Black belts

Polipropylene belts for boating. Roll packing.

| Articolo - Item | €/mt. | €/m ² | H mm. | Length mt. | kg. |
|-----------------|-------|------------------|-------|------------|-------|
| N 05 30 080 | | | 30 | 100 | 3,100 |

madeby



POLIPROPYLENE

Cinghie Bianche

Cinghie in Polipropilene Bianco per uso nautico. Vendute a rotolo.

White belts

Polipropylene belts for boating. Roll packing.

| Articolo - Item | €/mt. | €/m ² | H mm. | Length mt. | kg. |
|-----------------|-------|------------------|-------|------------|-------|
| N 05 30 074 | | | 30 | 100 | 3,150 |
| N 05 40 074 | | | 40 | 100 | 3,150 |
| N 05 50 074 | | | 50 | 100 | 3,950 |

madeby

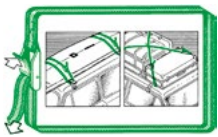

Cinghia in Poliestere Blue con fibbia in Zama

Blue polyester belt with Zama buckle

| Articolo - Item | €/m ² | Colore | H mm. | Length cm. | kg. | kg. |
|-----------------|------------------|--------|-------|------------|-----|-------|
| C 31 25 150 | | | 25 | 150 | 300 | 0,150 |
| C 31 25 250 | | | 25 | 250 | 300 | 0,160 |
| C 31 25 400 | | | 25 | 400 | 300 | 0,210 |

1 madeby



Cinghia regolabile in poliestere Arancio munita di fibbia autobloccante e di ganci terminali in acciaio zincato

Orange adjustable polyester belt with self-blocking buckle with end hooks in galvanised steel

| Articolo - Item | €/m ² | Colore | H mm. | Length cm. Adjustable | kg. | kg. |
|-----------------|------------------|--------|-------|-----------------------|-----|-------|
| C 15 25 300 | | | 25 | 60/300 | 500 | 0,450 |
| C 15 25 450 | | | 25 | 60/450 | 500 | 0,480 |
| C 15 25 600 | | | 25 | 60/600 | 500 | 0,530 |

1 madeby



AISI 316

Cinghia regolabile in Poliestere Blue munita di fibbia autobloccante e di ganci terminali in acciaio inox Aisi 316

Blue Polyester adjustable belt with selfblocking buckle with stainless steel Aisi 316 end hooks

| Articolo - Item | €/m ² | Colore | H mm. | Length cm. Adjustable | kg. | kg. |
|-----------------|------------------|--------|-------|-----------------------|-----|-------|
| C 15 32 600 | | | 25 | 60/600 | 900 | 0,510 |

1 madeby



Elastico per fissaggio serie «Super»

Indicato per carichi voluminosi, pesanti e per fissare imbarcazioni sulle auto.

«Super» shock cords

Suitable for bulky and heavy loads and to fasten boats on cars.

| Articolo - Item | €/pc. | Ø mm. | Length cm. | kg. |
|-----------------|-------|-------|------------|-------|
| C 14 14 150 | | 14 | 150 | 0,370 |
| C 14 14 250 | | 14 | 250 | 0,460 |

1 madeby

FIBBIE E PASSANTI | BUCKLES
AISI 316
Passante inox per cinghia
Stainless steel belt loop

| Articolo - Item | €/pc. | Per cinghia larghezza For belt width mm. | kg. |
|-----------------|-------|---|-------|
| C 17 40 032 | | 40 | 0,180 |
| C 17 50 032 | | 50 | 0,180 |



Passante in ottone per cinghia
Brass belt loop

| Articolo - Item | €/pc. | Per cinghia larghezza For belt width mm. | kg. |
|-----------------|-------|---|-------|
| C 17 50 034 | | 50 | 0,020 |



**Fibbia di chiusura
a flap per cinghia**
Webbing buckle

| Articolo - Item | €/pc. | €/Box 10pc | Per cinghia larghezza For belt width mm. | kg. |
|-----------------|-------|------------|---|-------|
| C 90 08 330 | | | 30 | 0,180 |
| C 90 08 340 | | | 40 | 0,400 |
| C 90 08 350 | | | 50 | 0,480 |

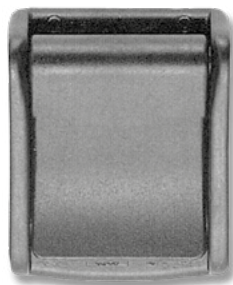

**Doppia fibbia di chiusura a
pulsanti laterali**
Double webbing buckle

| Articolo - Item | €/pc. | €/Box 10 pc | Per cinghia larghezza For belt width mm. | kg. |
|-----------------|-------|-------------|---|-------|
| C 90 17 025 | | | 25 | 0,130 |
| C 90 17 030 | | | 30 | 0,140 |
| C 90 17 040 | | | 40 | 0,180 |



**Triangoli e anelli
in acciaio inox**
**Stainless steel triangular and
rings**

| Articolo - Item | €/pc. | Filo-Wire Ø mm. | mm. | kg. |
|-----------------|-------|-----------------|---------|-------|
| C 17 08 045 | | 8 | 50 x 60 | 0,950 |



**Fibbia di chiusura regolabile
in acciaio inox**
**Stainless steel adjustable
buckle for belt**

| Articolo - Item | €/pc. | Per cinghia larghezza For belt width mm. | kg. |
|-----------------|-------|---|-------|
| C 17 40 080 | | 40 | 0,300 |



NYLON

Redance in nylon

Confezione in sacchetto.

Nylon thimbles

Packing in bag.

| Articolo - Item | €/pc. | €/Box | Ø mm. | pz.-pcs. | kg. |
|-----------------|-------|-------|-------|----------|-------|
| M 11 05 000 | | | 5 | 10 | 0,020 |
| M 11 06 000 | | | 6 | 10 | 0,030 |
| M 11 08 000 | | | 8 | 10 | 0,050 |
| M 11 10 000 | | | 10 | 10 | 0,050 |
| M 11 12 000 | | | 12 | 10 | 0,090 |
| M 11 14 000 | | | 14 | 10 | 0,150 |
| M 11 16 000 | | | 16 | 10 | 0,210 |
| M 11 19 000 | | | 19 | 10 | 0,310 |
| M 11 20 000 | | | 20 | 10 | 0,450 |
| M 11 24 000 | | | 24 | 10 | 0,750 |



AISI 316

Redance in acciaio inox

Confezione in sacchetto.

Stainless steel thimbles

Packing in bag.

| Articolo - Item | €/pc. | €/Box | Ø mm. | pz.-pcs. | kg. |
|------------------------|-------|-------|-------|----------|-------|
| M 10 02 000 | | | 2 | 10 | 0,015 |
| M 10 03 000 | | | 3 | 10 | 0,025 |
| M 10 04 000 | | | 4 | 10 | 0,040 |
| M 10 05 000 | | | 5 | 10 | 0,060 |
| M 10 06 000 | | | 6 | 10 | 0,080 |
| M 10 08 000 | | | 8 | 10 | 0,150 |
| M 10 10 000 | | | 10 | 10 | 0,230 |
| M 10 12 000 | | | 12 | 10 | 0,420 |
| M 10 14 000 | | | 14 | 10 | 0,560 |
| M 10 16 000 | | | 16 | 10 | 1,200 |
| M 10 18 000 | | | 18 | 4 | 0,540 |
| M 10 20 000 | | | 20 | 4 | 0,590 |
| M 10 22 000 NEW | | | 22 | 4 | 0,700 |
| M 10 24 000 NEW | | | 24 | 4 | 0,920 |



AISI 316

Redance inox «Super Strong»

Stainless steel thimbles «Super Strong»

| Articolo - Item | €/pc. | Ø mm. | kg. |
|-----------------|-------|-------|-------|
| M 10 26 000 | | 26 | 0,600 |
| M 10 28 000 | | 28 | 0,760 |
| M 10 30 000 | | 30 | 0,950 |



AISI 316

Anelle in acciaio inox

Indispensabili per fissare la corda elastica all'estremità dei ganci.

Stainless steel clamp rings

For shock cord fastening.

| Articolo - Item | €/pc. | €/Box | Per corda elastica Ø mm. For shock cord Ø mm. | kg. |
|-----------------|-------|-------|--|-------|
| C 09 04 002 | | | 4 | 0,200 |
| C 09 06 003 | | | 6 | 0,300 |
| C 09 08 005 | | | 8 | 0,500 |
| C 09 10 006 | | | 10 | 0,800 |



Pinza per fissaggio anellini

Indicata per chiudere gli anellini in ottone o in acciaio sulla corda elastica.

Crimping tool

Suitable for crimp clamps to shock cord.

| Articolo - Item | €/pc. | kg. |
|-----------------|-------|-------|
| C 08 00 240 | | 0,250 |



Capicorda termorestringenti «Fast End» per cime e trecce

Capicorda termorestringenti per trecce. Capicorda da 4 cm.

Terminal «Fast End» for braided and strand ropes

Available for Ø 6,5 to max. 12,5 mm. and from Ø 10 to max. 19 mm.

| Articolo - Item | €/ La confezione 6 pz. €/Packing of 6 pcs. | Ø mm. | kg. |
|-----------------|---|-------------------------|-------|
| L 54 12 004 | | da min. 6,5 a max. 12,5 | 0,060 |
| L 54 19 004 | | da min. 10 a max. 19 | 0,120 |

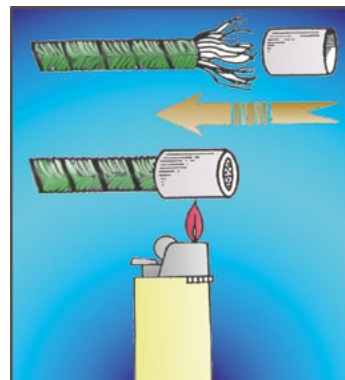

Punteruolo in acciaio inox per impiombature

Fabbricato in acciaio inox, provvisto di manico di legno.

Stainless steel puncher for splicing

Made of stainless steel with wooden handle.

| Articolo - Item | €/pc. | Modello - Model | Length cm. | kg. |
|-----------------|-------|-----------------|------------|-------|
| F 00 00 018 | | Medio - Medium | 18 | 0,040 |
| F 00 00 027 | | Grande - Large | 27 | 0,140 |



AISI 316

Kit aghi in acciaio per impiombare

Stainless steel needles for splicing

| Articolo - Item | €/Kit | Descrizione - Description | kg. |
|-----------------|-------|--|-------|
| F 01 32 175 | | Kit composto da 4 aghi 2-20 mm. Kit with 4 needles 2-20 mm. | 0,200 |



Aghi per reti

Fabbricati in nylon elasticizzato di colore arancio.

Needles for fishing net

Made of orange nylon.

| Articolo - Item | €/pc. | €/Box | mm. | pcs. | kg. |
|-----------------|-------|-------|------------|------|-------|
| F 01 00 150 | | | 6 x 150 | 20 | 0,400 |
| F 01 00 175 | | | 8 x 175 | 20 | 0,500 |
| F 01 00 210 | | | 12 x 210 | 20 | 0,600 |
| F 01 00 229 | | | 15,5 x 230 | 20 | 0,700 |

made by



Kit per impiombare con serraggio a vite di semplice e veloce utilizzo

Riutilizzabile. Completa di chiave di serraggio.

Splicing kit with screw fastening system

Complete with fastening key. Reusable.

| Articolo - Item | Confezione da 2 pz. Packing of 2 pcs. | Ø cima rope mm. | kg. |
|-----------------|---------------------------------------|-----------------|-------|
| N 33 04 079 | | 4 | 0,110 |



GANCI E BORCHIE | HOOKS & GROMMETS

Terminali fermacorda a molla

Realizzati in nylon.

Spring terminal caps

Made in nylon.

| Articolo - Item | €/pc. | €/Box | Colore Colour | Foro Hole Ø mm. | pcs. | kg. |
|-----------------|-------|-------|---------------|-----------------|------|-------|
| C 90 08 338 | | | | 8 | 10 | 0,030 |



Terminali di fissaggio per copri barche

Fabbricati in nylon ad alta resistenza.

«Utility clip» fastening

Made in high resistance nylon.

| Articolo - Item | €/pc. | €/Box | Ø mm. | pcs. | kg. |
|-----------------|-------|-------|-------|------|-------|
| C 25 06 010 | | | 6 | 50 | 0,150 |
| C 25 08 012 | | | 8 | 50 | 0,160 |

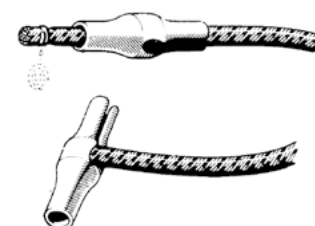

GANCI E BORCHIE | HOOKS & GROMMETS

Gancio in nylon per tubo ø 20mm e 25mm indicato per corda elastica Ø 8 mm.

Nylon hook for pipe ø 20mm and 25mm suitable for Ø 8 mm. elastic rope

| Articolo - Item | €/pc. | €/Box | per tubo - for hose Ø mm. | Colore Colour | pcs. | kg. |
|-----------------|-------|-------|------------------------------|------------------|------|-------|
| C 26 20 008 | | | 20 | ■ | 10 | 0,050 |
| C 26 25 008 | | | 25 | ■ | 10 | 0,060 |
| C 13 20 008 | | | 20 | □ | 10 | 0,050 |
| C 13 25 008 | | | 25 | □ | 10 | 0,060 |

madeby 



Ganci in acciaio inox

Stainless steel hooks

Adatti per l'applicazione all'estremità delle corde elastiche.

For application on shock cords.

| Articolo - Item | €/pc. | €/Box | per corda elastica for shock cord Ø mm. | pcs. | kg. |
|-----------------|-------|-------|---|------|-------|
| C 09 06 018 | | | 6 | 10 | 0,200 |
| C 09 08 024 | | | 8 | 10 | 0,250 |
| C 09 10 032 | | | 10 | 10 | 0,340 |

madeby 



Ganci in nylon «Pratic»

Nylon hooks «Pratic»

| Articolo - Item | €/pc. | €/Box | Ø mm. | pcs. | kg. |
|-----------------|-------|-------|-------|------|-------|
| C 13 06 011 | | | 8 | 20 | 0,200 |

madeby 



Gancio a montaggio automatico Self-tailing hook

| Articolo - Item | € Sacchetto da 6 pz. | per corda elastica for shock cord Ø mm. | Colore Colour | kg. |
|-----------------|----------------------|---|------------------|-------|
| C 28 06 080 | | 6 | ■ | 0,024 |

madeby 



Gancio a moschettone a montaggio automatico indicato per corda elastica ø 6 e 8 mm.

Self-tailing snap hook for shock cord ø 6 and 8 mm.

Fabbricato in nylon di colore nero e bianco. Gancio fissabile a scatto con un efficace sistema autobloccante.

Made of black and white nylon.

| Articolo - Item | €/pc. | €/Box | per corda elastica for shock cord Ø mm. | Colore Colour | pcs. | kg. |
|-----------------|-------|-------|---|------------------|------|-------|
| C 28 05 080 | | | 5-6 | ■ | 50 | 0,180 |
| C 26 08 019 | | | 8 | ■ | 50 | 0,715 |
| C 28 05 074 | | | 5-6 | □ | 50 | 0,180 |
| C 26 08 074 | | | 8 | □ | 50 | 0,715 |

madeby 



Terminali autobloccanti mod. «Olive Clips» per fissaggio corda elastica

«Olive Clips» for shock cord fastening

Fabbricati in nylon ad alta resistenza.

Made of high resistance nylon.

| Articolo - Item | €/pc. | €/Box | per corda elastica for shock cord Ø mm. | Colore Colour | pcs. | kg. |
|-----------------|-------|-------|---|------------------|------|-------|
| C 25 05 015 | | | 5 | ■ | 50 | 0,280 |
| C 25 06 015 | | | 6 | ■ | 50 | 0,280 |
| C 25 08 015 | | | 8 | ■ | 50 | 0,330 |

madeby 



Ganci speciali in nylon

Per applicazioni industriali.
Montaggio tramite nodo.

Special nylon hooks

Knot fitting.

| Articolo - Item | €/pc. | €/Box | Articolo - Item | €/pc. | €/Box | Foro - Hole Ø mm. | pcs. |
|-----------------|-------|-------|-----------------|-------|-------|----------------------|------|
| C 13 04 000 | | | C 26 04 000 | | | 4 | 10 |
| C 13 06 000 | | | C 26 06 000 | | | 6 | 10 |
| C 13 08 000 | | | C 26 08 000 | | | 8 | 10 |
| C 13 10 000 | | | - | | | 10 | 10 |

madeby 



Ganci in nylon

Montaggio tramite nodo.

Nylon hooks

Knot fitting.

| Articolo - Item | Articolo - Item | €/pc. | €/Box | Foro - Hole Ø mm. | pcs. | kg. |
|-----------------|-----------------|-------|-------|----------------------|------|-------|
| C 13 04 015 | C 26 04 015 | | | 5 | 50 | 0,650 |

madeby 



Gancio in nylon

Montaggio tramite nodo.

Nylon hook

Knot fitting.

| Articolo - Item | €/pc. | €/Box | Foro - Hole Ø mm. | pcs. | kg. |
|-----------------|-------|-------|----------------------|------|-------|
| C 13 04 013 | | | 5 | 50 | 0,650 |

madeby 



Gancio in nylon a moschettone

Montaggio tramite nodo.

Nylon hook

Knot fitting.

| Articolo - Item | €/pc. | €/Box | Foro - Hole Ø mm. | pcs. | kg. |
|-----------------|-------|-------|----------------------|------|-------|
| C 13 08 012 | | | 8 | 10 | 0,130 |
| C 13 10 014 | | | 10 | 10 | 0,150 |

madeby 





Borchie a montaggio rapido in confezione «Self-service»

Fabbricate in plastica.

Plastic grommet «Self-service» packing

Made of plastic.

| Articolo - Item | €/ cartella da 12 pz. €/Box of 12 pcs. | Foro - Hole Ø mm. | Colore Colour | kg. |
|-----------------|---|----------------------|---|-------|
| A 22 14 000 | | 15 |  | 0,200 |
| A 22 16 000 | | 15 |  | 0,200 |
| A 22 17 000 | | 15 |  | 0,200 |

madeby 





Borchie a montaggio rapido

Fabbricate in plastica.

Plastic grommet

Made of plastic.

| Articolo - Item | €/pc. | €/Box | Foro - Hole Ø mm. | Ø est. mm. | Asola-Eyelet Ø mm. | Colore Colour | H mm. | kg. |
|-----------------|-------|-------|----------------------|------------|-----------------------|---|----------|-------|
| A 22 14 020 | | | 15 | 35 | 20 |  | 0,7 | 0,750 |
| A 22 16 020 | | | 15 | 35 | 20 |  | 0,7 | 0,750 |
| A 22 17 020 | | | 15 | 35 | 20 |  | 0,7 | 0,750 |

madeby 



Gancio a S S hook

| Articolo - Item | €/pc. | €/box | Ø mm. | kg. |
|-----------------|-------|-------|-------|-------|
| H 10 08 000 | | | 8 | 0,420 |



Anelle a D D ring

| Articolo - Item | €/pc. | €/box | L mm. | kg. |
|-----------------|-------|-------|-------|-------|
| H 12 35 000 | | | 35 | 0,330 |

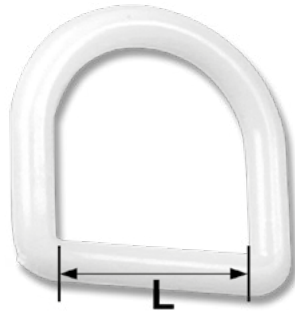

Gancio doppio e contropiastra Double hook with plate

| Articolo - Item | €/pc. | €/box | Mod. | H mm. | X mm. | kg. |
|-----------------|-------|-------|------|-------|-------|-------|
| H 10 32 065 | | | A | 66 | 22 | 0,740 |
| H 10 32 030 | | | B | 34 | 22 | 0,065 |

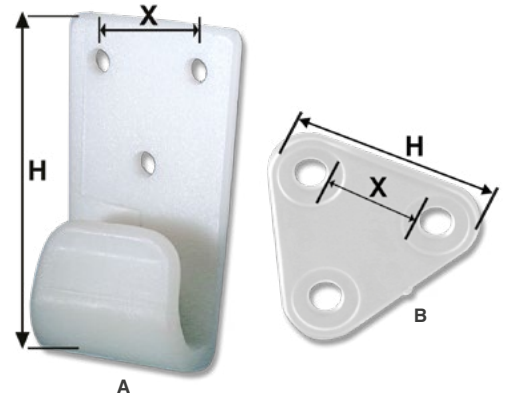

Gancio grande Hook

| Articolo - Item | €/pc. | €/box | H mm. | X mm. | kg. |
|-----------------|-------|-------|-------|-------|-------|
| H 10 08 237 | | | 55 | 30 | 0,720 |

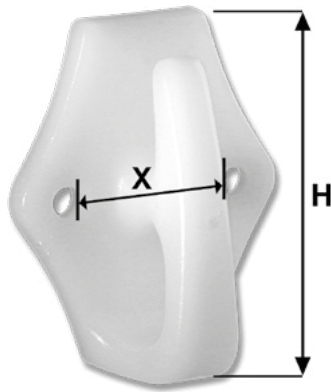

Ganci in nylon Nylon hooks

Fissaggio mediante viti.
Colore nero.

Fitting by screws.
Black colour.

| Articolo - Item | €/pc. | €/box | L mm. | X mm. | kg. |
|-----------------|-------|-------|-------|-------|-------|
| A 21 00 020 | | | 39 | 29 | 0,240 |



Gancetto per telo copribarche

Realizzato in nylon.

Hooks for boats cover application

Made of nylon.

| Articolo - Item | €/pc. | €/box | Foro corda Rope hole Ø mm. | mm. | kg. |
|-----------------|-------|-------|-------------------------------|-------|-------|
| O 11 06 040 | | | 8 | 38x40 | 0,440 |

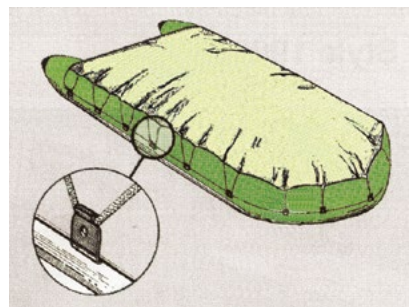

CONTAMETRI | ROPE COUNTER

Contametri manuale

Rope counter

| Articolo - Item | €/pc. | Adatto per - Adapt for | kg. |
|-----------------|-------|------------------------------------|-------|
| F 01 00 024 | | Corde fino a 24mm- Up to 24mm rope | 0,550 |



Telaio da banco completo di contametri per misurazione corde e trecce da Ø 3 a Ø 24mm.

Countmeter for ropes measurement from Ø 3 up to Ø 24mm.

Attrezzo adatto per la misurazione di corde munito di levetta per l'azzeramento.

Suitable for measuring of rope length. Including zero setting system.

| Articolo - Item | €/pc. | Modello - Model | kg. |
|-----------------|-------|---------------------|-------|
| F 01 00 060 | | Completo - Complete | 1,050 |

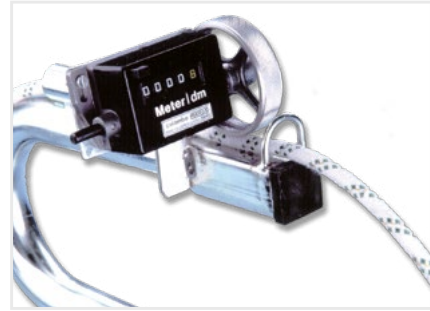

CESOIE | ROPE CUTTER

Cesoia speciale taglia corda elettrica con lama

Electric rope cutter with high quality blade

120V./230V.
Modello originale tedesco.

120V./230V.
Made in Germany.

| Articolo - Item | €/pc. | Confezione - Packing | kg. |
|-----------------|-------|-------------------------------------|-------|
| F 02 00 110 | | Cesoia con lama - Cutter with blade | 1,100 |
| F 03 00 011 | | Lama di ricambio - Spare blade | 0,110 |



SPARE PARTS



Cesoia taglia cime modello economico

Rope cutter with blade

60W. 120V./230V.

60W. 120V./230V.

| Articolo - Item | €/pc. | Confezione - Packing | W. | kg. |
|-----------------|-------|-------------------------------------|----|-------|
| F 02 79 803 | | Cesoia con lama - Cutter with blade | 60 | 1,100 |
| F 03 79 102 | | Lama di ricambio - Spare blade | - | 0,030 |



SPARE PARTS



DISPOSITIVO ANTIRATTO | ANTI-RAT DEVICE

Dispositivo anti-ratto per evitare la presenza di topi a bordo

Anti-rat device

Fabbricato in plastica trasparente resistente ai raggi UV.

Made of UV resistant plastic. Application on mooring rope.

| Articolo - Item | €/pc. | Ø mm. | Foro - Hole Ø mm. | kg. |
|-----------------|-------|-------|-------------------|-------|
| N 35 10 180 | | 180 | 10 ÷ 20 | 0,400 |

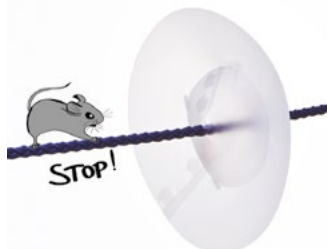



N5360100



N5354030

Clips speciale portacime in nylon

Munita di viti per l'applicazione anche lungo i candelieri o su pareti in genere.

Special nylon line holders

Provided with stainless steel screws.

| Articolo - Item | €/pc. | Attacco - Fitting | kg. |
|-----------------|-------|----------------------------------|-------|
| N 53 60 100 | | A parete - Wall fitting | 0,150 |
| N 53 54 030 | | Montaggio pulpito - Pipe fitting | 0,120 |



Gancio porta cima in nylon e porta anulare fissaggio tubo

Munito di corda elastica per il fissaggio e di morsetto con viti.

Line, ringbuoy or horseshoe nylon holder pipe fitting

Complete with shock cord and clamp with screws.

| Articolo - Item | €/pc. | Modello - Model | kg. |
|-----------------|-------|------------------------|-------|
| N 53 45 080 | | Universale - Universal | 0,150 |



T-Tape cinghia in velcro multiuso

Pratico ed altamente resistente. Ottimo per fissare cime vele ed altri oggetti in barca. Realizzato in poliestere.

T-Tape multifunctional tape

Practical and highly resistant. Suitable to fix ropes, liferings, electric cables or other things. Manufactured in polyester.

| Articolo - Item | €/pair | mm. | kg. |
|-----------------|--------|----------------------------|-------|
| N 33 40 050 | | 500 (Length) x 40 (Width) | 0,040 |
| N 33 40 100 | | 1000 (Length) x 40 (Width) | 0,065 |



PROFILI DI PROTEZIONE | RUBBING STRAKE PROFILES

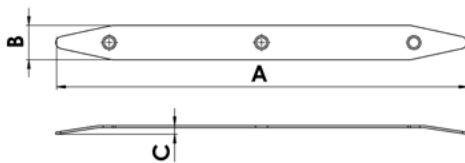

Profili di protezione contro lo sfregamento delle cime di ormeggio

Rubbing strake profiles, mirror polished

| Articolo - Item | €/pc. | A mm. | B mm. | C mm. | kg. |
|-----------------|-------|-------|-------|-------|-------|
| N 35 19 203 | | 203 | 19 | 6 | 0,045 |
| N 35 19 304 | | 304 | 19 | 6 | 0,070 |
| N 35 19 457 | | 457 | 19 | 6 | 0,090 |
| N 35 25 304 | | 304 | 25,4 | 6 | 0,090 |
| N 35 25 457 | | 457 | 25,4 | 6 | 0,130 |



VERRICELLI SALPANCORA | WINDLASSES

AIISI 316

Verricello ITALWINCH Smart

Carcassa in acciaio inox Aisi 316 lucidato.
Può utilizzare catena o cima-catena.
Sensore contometri integrato. Motore stagno IP67.
Consigliato per barche fino a 10 mt.

| Articolo - Item Alto campana + Barbotin | Articolo - Item Basso senza campana | Motore-Engine €/pc. | V | | Consumo medio A | Barbotin catena mm. | Ø cima mm. | Capacità di tiro max kg. | Carico di lavoro kg. | Velocità di recupero | |
|---|---|------------------------|----|-----|--------------------|---------------------------|---------------|--------------------------------|-------------------------|-------------------------|---------|
| | | | V | W | | | | | | m/min | kg. |
| N 68 12 507 | N 68 12 506 | | 12 | 500 | 60 | 6 | 12 | 270 | 90 | 23 | 8,5/9,5 |
| - | N 68 12 706 | | 12 | 700 | 90 | 6 | 12 | 300 | 100 | 25 | 8,5/9,5 |
| - | N 68 12 708 | | 12 | 700 | 90 | 8 | 12 | 300 | 100 | 25 | 8,5/9,5 |

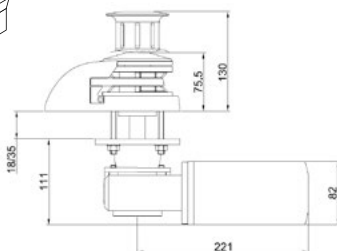

Windlass ITALWINCH Smart

Aisi316 vertical windlass.
Suitable for rope or rope/chain.
Comes with built-in chain counter sensor. IP67 engine.
Recommended for boats up to 10 m.



Control Box MZ ELECTRONIC Contattori/Invertitori

Gruppi di potenza per comando verricelli salpANCORA con motori a 3 o 4 fili o magneti permanenti. Totalmente stagni (IP56).
Abbinabili a tutti i comandi a piede a mano o portatili.

| Articolo - Item | €/pc. | V | Per motori da W max | Per motori con n. poli | Length mm. | Corrispondenza | | |
|-----------------|-------|-----------|------------------------|---------------------------|---------------|-------------------|----------|---------------|
| | | | | | | LEWMAR | QUICK | MZ ELECTRONIC |
| L 06 12 130 | 12 | 1000/1500 | | 2/4 | 148x60x95 | 68000320 | T6415-12 | MZ2130/H |
| L 06 24 250 | 24 | 1500/3000 | | 2/4 | 148x70x120 | - | T6415-24 | MZIC20134 |
| L 06 15 012 | 12 | 1000/1500 | | 3 | 148x60x95 | 68000937/68000318 | T6315-12 | MZ2150/C |
| L 06 24 130 | 24 | 500/1400 | | 3 | 148x60x95 | 68000938/68000319 | T6315-24 | MZ2150/D |
| L 06 20 012 | 12 | 1700/2300 | | 3 | 130x70x120 | 68000318 | T6315-12 | MZ2150PA/C |
| L 06 24 180 | 24 | 1500/2300 | | 3 | 148x60x95 | 68000319 | T6315-24 | MZ2150PA/D |



Control Box MZ ELECTRONIC Contactors/Inverters

Control devices for 3 or 4 wires and permanent magnet DC motors. IP56.
Can be used with all models of foot/hand controls.



Pulsantiera a 2 pulsanti

Create per l'applicazione in corrente continua ed a tenuta stagna.

| Articolo - Item | €/pc. | mm. | kg. |
|-----------------|-------|---------------------|-------|
| L 06 02 145 | | L 50 x P 22 x H 145 | 0,700 |



Hand held remote control unit

Built for direct current applications and perfectly watertight.

Comandi a piede

Pulsante a perfetta tenuta stagna.
Portata massima: 4 A.
Base in acciaio inox.

Electric foot switch

Perfectly watertight control for relays or other loads. Perfect watertight execution. Max loading: 4 A. Stainless steel base.

| Articolo - Item | €/pc. | Mod. | Colore Colour | Tipo - Type | Coperchio Cover | kg. |
|-----------------|-------|-----------|------------------|-------------------------------------|---------------------|-------|
| L 06 01 210 | | F0SWI 210 | ■ | Comando discesa Foot switch down | Plastica Plastic | 0,190 |
| L 06 01 220 | | F0SWI 220 | ■ | Comando salita Foot switch up | Plastica Plastic | 0,190 |



Salpa ancora Aisi 316

Completo di salpancora e maniglia.

Heavy duty windlass Aisi 316

Complete with handle.

| Articolo - Item | N 35 11 012 | N 35 11 524 | N 35 11 512 |
|--|--|--------------------|--|
| Modello - Model | Con campana-W/drum | Con campana-W/drum | Con campana-W/drum |
| Materiale cassa esterna - Deck material | Aisi 316 | Aisi 316 | Aisi 316 |
| Materiale barbotin e campana - Drum & Gipsy material | Aisi 316 | Aisi 316 | Aisi 316 |
| Potenza motore - Electric Motor (W) | 1000 | 1500 | 1500 |
| Tensione - Motor supply voltage (V) | 12 | 24 | 12 |
| Assorbimento - Current absorbtion (A) | 55 | 65 | 115 |
| Carico di lavoro - Lift load (kg) | 250 | 485 | 485 |
| Tiro istantaneo massimo - Pull max (kg) | 750 | 1200 | 1200 |
| Velocità di recupero - Line speed (m/min) | 40 | 40 | 40 |
| Catena supportata - Chain | Cima catena - Chain rope (Din766 HT G4) Ø 7mm (Din766 HT G4) Ø 8mm | | Cima catena - Chain rope (Din766 HT G4) Ø 8 mm. e 10 mm. |
| Cima supportata - Rope | Ø 12 - 14 mm. | | |
| Peso - Weight kg | 20 | 22 | 22 |
| €/pc. | | | |

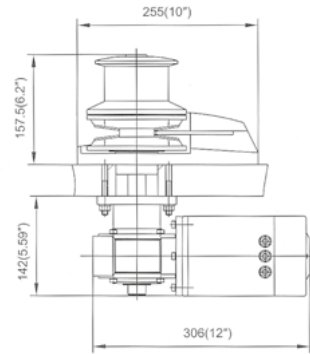
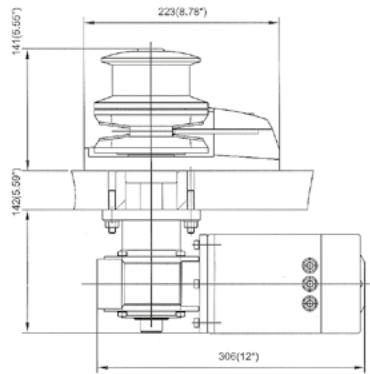

SCUDI PROTEGGI PRUA | BOWSHIELDS

AISI 316

Proteggi prua

Realizzati in acciaio inox. Modellabili manualmente.

Bowshields

Manufactured in stainless steel. To be shaped by hand.

| Articolo - Item | €/pc. | Mod. | A mm. | B mm. | Spessore - Depth mm. | kg. |
|-----------------|-------|------|-------|-------|----------------------|------|
| N 35 03 000 | | 1 | 265 | 345 | 1,5 | 0,70 |
| N 35 03 010 | | 2 | 350 | 345 | 1,5 | 0,95 |
| N 35 03 011 | | 3 | 320 | 277 | 1,5 | 0,70 |



made by

N3503000

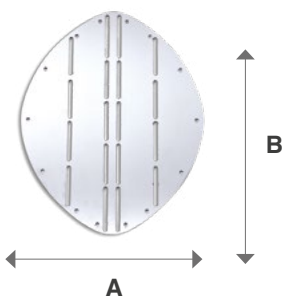

N3503010

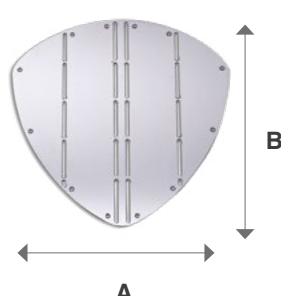

N3503011

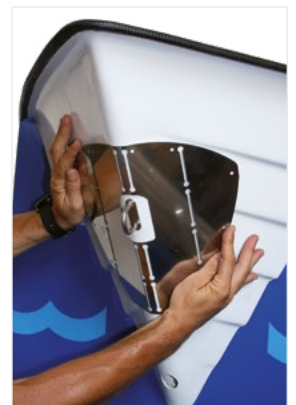
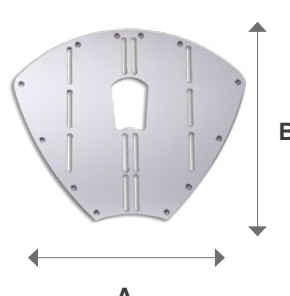

ACCESSORI ANCORE | ANCHORS ACCESSORY

Kit anello per recupero ancore | Anchor Retriever System

Legare la corda da un lato al parabordo e dall'altro al moschettone. Fissare quindi il moschettone all'anello. Abbassare il galleggiante e trainare l'ancora ad una velocità di 6-8 nodi. Il galleggiante fa scendere la cima d'ancora fino all'ancora, liberandola dal fondo e riportandola in superficie.

Fasten the line to the fender from one side and to the snap hook from the other side. Fix the snap hook to the anchor ring. Lower the ball overboard and run past the anchor at 6-8 knots. The ball moves down the line to the anchor, pulling it free and floating it to the surface.

| Articolo - Item | €/kit. | Mod. | pcs. | kg. |
|-----------------|--------|--|-------|-------|
| N 06 07 090 | | Anello + Moschettone + Cima Ring + Snap hook + Line | 1 kit | 0,350 |

made by 

SUGGESTED ITEM

Art. P1835048

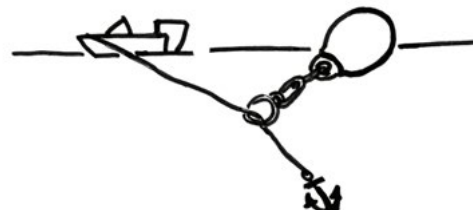
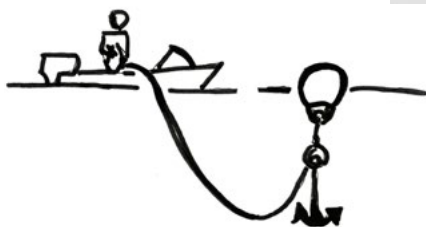

ANCORE | ANCHORS ACCESSORY

Ancore galleggianti «UNIVERSALE»

Fabbricate in tela di Pvc spalmato. Modello pieghevole.

Drag anchors «UNIVERSALE»

Made of very strong nylon cloth. Supplied with nylon rope.

| Articolo - Item | €/pc. | Bocca-Opening Ø mm. | Per imbarcazioni fino a For boats up to mt. | kg. |
|-----------------|-------|------------------------|--|-------|
| N 13 50 000 | | 500 | 7 | 1,400 |
| N 13 60 000 | | 600 | 8 | 1,500 |
| N 13 70 000 | | 700 | 9 | 1,600 |
| N 13 80 000 | | 800 | 10 | 1,750 |

made by 



SQUIDDY

Ancora galleggiante «SQUIDDY»

Modello professionale fabbricato in tessuto Rip-Stop in nylon a trama larga spalmato in Pvc doppio gold.

Bandelle di traino e rinforzo delle bocche in nastro nylon.

Drag anchor «SQUIDDY»

Professional model made in Rip-stop nylon fabric with a loose weave coated PVC double gold.

Tow straps and reinforcement of the mouth with nylon tape.

| Articolo - Item | €/pc. | Width mm. | Length mm. | Consigliata per barche mt. Suitable for boats mt. | kg. |
|-----------------|-------|-----------|------------|--|-------|
| N 13 06 053 | | 500 | 530 | 6 | 0,180 |
| N 13 08 070 | | 700 | 700 | 8 | 0,460 |
| N 13 10 110 | | 1070 | 1000 | 10 | 0,490 |
| N 13 13 140 | | 1350 | 1300 | 12 | 0,720 |

made by 

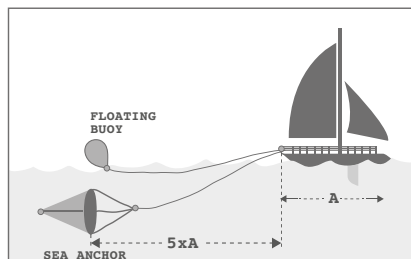

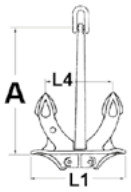

Ancora «Hall» classica

Fabbricata in acciaio zincato a caldo, robusta per tutti i fondali. Braccio snodato a forte angolazione.

«Hall» Anchor

Made of hot galvanised steel.

| Articolo - Item | €/pc. | A mm. | L1 mm. | L4 mm. | kg. |
|-----------------|-------|-------|--------|--------|-------|
| N 11 00 003 | | 290 | 160 | 140 | 2,70 |
| N 11 00 004 | | 320 | 180 | 170 | 4,20 |
| N 11 00 006 | | 350 | 210 | 210 | 6,20 |
| N 11 00 008 | | 380 | 230 | 230 | 8,80 |
| N 11 00 010 | | 400 | 240 | 240 | 10,50 |



Ancora tipo «Fishing»

Fabbricata in acciaio zincato a caldo.

«Fishing» Anchor

Made of hot galvanised steel.

| Articolo - Item | €/pc. | Misure - Size mm. | kg. |
|-----------------|-------|-------------------|------|
| N 37 08 962 | | 4 Pronds - 8 mm. | 1,20 |
| N 37 10 963 | | 4 Pronds - 12 mm. | 3,20 |

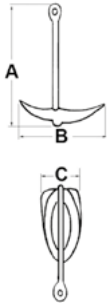

SENZA GRILLO
W/OUT SHACKLE

CON GRILLO
WITH SHACKLE

Ancora ad ombrello

Versione in acciaio fuso e zincato a caldo. Contrappeso sul fusto per un migliore bilanciamento dell'ancora (Sistema SAV norvegese)

Grapple anchor

Made of hot galvanised steel. Provided with counterbalance.

| Articolo - Item Senza grillo Without shackle | €/pc. | Articolo - Item Con grillo With shackle | €/pc. | A mm. | B mm. | C mm. | kg. |
|--|-------|---|-------|-------|-------|-------|-------|
| N 10 30 015 | | N 10 20 015 | | 310 | 265 | 75 | 1,50 |
| N 10 30 023 | | N 10 20 023 | | 360 | 315 | 85 | 2,50 |
| N 10 30 031 | - | | | 420 | 365 | 100 | 3,20 |
| N 10 30 040 | | N 10 20 035 | | 470 | 380 | 110 | 4,00 |
| N 10 30 061 | | N 10 20 055 | | 565 | 440 | 130 | 6,00 |
| - | | N 10 20 075 | | 575 | 490 | 140 | 8,00 |
| - | | N 10 20 100 | | 610 | 595 | 130 | 10,00 |

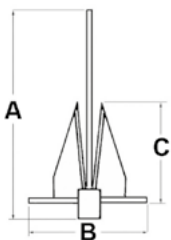

Ancora tipo «Danforth»

Fabbricata in acciaio zincato a caldo.

«Danforth» Anchor

Made of hot galvanised steel.

| Articolo - Item | €/pc. | A mm. | B mm. | C mm. | kg. |
|-----------------|-------|-------|-------|-------|-------|
| N 12 00 004 | | 505 | 425 | 295 | 4,00 |
| N 12 00 006 | | 610 | 450 | 335 | 6,00 |
| N 12 00 008 | | 670 | 460 | 380 | 8,00 |
| N 12 00 010 | | 705 | 520 | 420 | 10,00 |
| N 12 00 012 | | 800 | 600 | 550 | 12,00 |

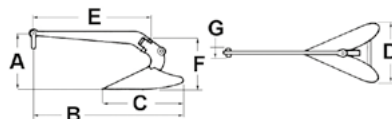
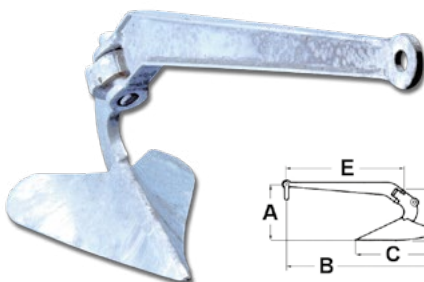

Ancora tipo «CQR»

Fabbricata in acciaio ad alta resistenza, zincata a fuoco a forte spessore. Offre ottime prestazioni su tutti i tipi di fondale.

«CQR» Anchor

Made of hot galvanised steel high resistance. It offers excellent performance on any kind of sea bed.

| Articolo - Item | €/pc. | A mm. | B mm. | C mm. | D mm. | E mm. | F mm. | G mm. | kg. |
|-----------------|-------|-------|-------|-------|-------|-------|-------|-------|-------|
| N 37 20 000 | | 400 | 1050 | 490 | 360 | 800 | 345 | 80 | 22,00 |



Ancora «Hand»

«Hand» Anchor

Fabbricata in acciaio fuso zincato a caldo.
Ad interrimento progressivo.

Made of hot galvanised steel.

| Articolo - Item | €/pc. | A mm. | B mm. | C mm. | kg. |
|-----------------|-------|-------|-------|-------|-------|
| N 37 00 045 | | 273 | 469 | 310 | 5,00 |
| N 37 00 085 | | 298 | 531 | 360 | 7,50 |
| N 37 00 110 | | 320 | 583 | 380 | 10,00 |
| N 37 00 150 | | 335 | 655 | 405 | 15,00 |
| N 37 00 200 | | 395 | 701 | 470 | 21,00 |
| N 37 00 300 | | 410 | 800 | 560 | 32,00 |

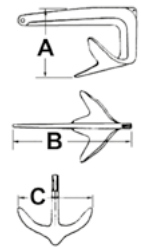

AISI 316

Ancora «Hand Inox»

«Hand Inox» Anchor

| Articolo - Item | €/pc. | A mm. | B mm. | C mm. | kg. |
|-----------------|-------|-------|-------|-------|-------|
| N 37 32 050 | | 240 | 470 | 320 | 5,00 |
| N 37 32 075 | | 270 | 540 | 360 | 7,50 |
| N 37 32 100 | | 310 | 590 | 385 | 11,00 |
| N 37 32 150 | | 335 | 645 | 450 | 15,00 |
| N 37 32 200 | | 355 | 660 | 475 | 20,00 |
| N 37 32 300 | | 410 | 815 | 560 | 30,00 |

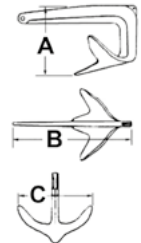

Ancora in acciaio zincato

Anchor in galvanised steel

Eccezionale tenuta con qualsiasi fondale (alghie incluse).
Grande capacità di aumentare la presa all'aumentare del vento.

High grip on any type of seabed.
Consistent and reliable in performance, this anchor increases grip with increasing wind.

| Articolo - Item | €/pc. | A mm. | B mm. | C mm. | D mm. | E mm. | Recommended chain mm. | For boats up to mt. | kg. |
|-----------------|-------|-------|-------|-------|-------|-------|-----------------------|---------------------|-------|
| N 37 24 004 | | 514 | 228 | 8 | 387 | 210 | 6-7 | 7 | 4,00 |
| N 37 24 006 | | 595 | 263 | 10 | 450 | 241 | 6-7 | 9 | 6,00 |
| N 37 33 100 | | 695 | 308 | 12 | 526 | 283 | 8 | 11 | 10,00 |
| N 37 24 016 | | 812 | 360 | 12 | 614 | 334 | 8 | 13 | 16,00 |
| N 37 33 200 | | 877 | 389 | 16 | 663 | 361 | 10 | 15,5 | 20,00 |
| N 37 24 032 | | 1026 | 455 | 20 | 774 | 417 | 10 | 18,5 | 32,00 |
| N 37 24 040 | | 1099 | 489 | 20 | 835 | 446 | 10 | 20 | 40,00 |

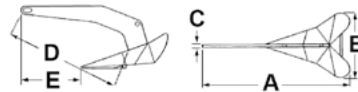

AISI 316

Ancora in acciaio inox

Anchor in stainless steel

Ultra resistente, ad elevato potere di tenuta.

Heavy duty anchor, high holding power.

| Articolo - Item | €/pc. | A mm. | B mm. | C mm. | D mm. | E mm. | Recommended chain mm. | For boats up to mt. | kg. |
|-----------------|-------|-------|-------|-------|-------|-------|-----------------------|---------------------|-------|
| N 37 50 010 | | 695 | 308 | 12 | 526 | 283 | 8 | 11 | 10,00 |
| N 37 50 016 | | 812 | 360 | 12 | 614 | 334 | 8 | 13 | 16,00 |
| N 37 50 020 | | 877 | 389 | 16 | 663 | 361 | 10 | 15,5 | 20,00 |

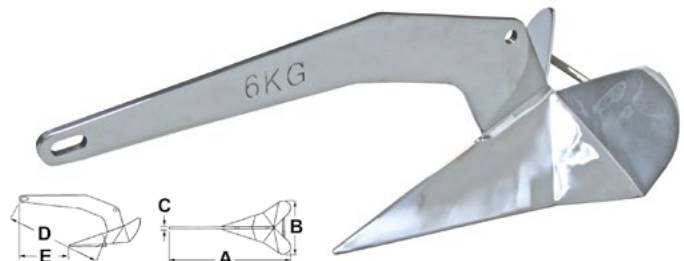

Ancora mod. «Rhino»

«Rhino» Anchor

Fabbricata in acciaio stampato e zincata a caldo.
Confezione in sacchi.

Made of hot galvanised drop-forged steel.
Packing in bags.

| Articolo - Item | €/pc. | A mm. | B mm. | C mm. | D mm. | E mm. | kg. |
|-----------------|-------|-------|-------|-------|-------|-------|------|
| N 37 33 050 | | 550 | 200 | 8 | 350 | 200 | 5,0 |
| N 37 33 075 | | 650 | 270 | 10 | 500 | 250 | 7,5 |
| N 37 33 150 | | 800 | 350 | 16 | 650 | 350 | 15,0 |

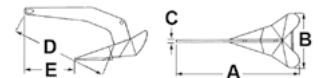

Ancora triangolare con arco

Triangle plate anchor

Fabbricata in acciaio stampato.

Made of hot galvanised steel.

| Articolo - Item | €/pc. | pcs. | kg. |
|-----------------|-------|------|-------|
| N 37 10 075 | | 1 | 7,50 |
| N 37 10 090 | | 1 | 9,00 |
| N 37 10 110 | | 1 | 11,00 |
| N 37 10 140 | | 1 | 14,00 |
| N 37 10 160 | | 1 | 16,00 |
| N 37 10 200 | | 1 | 20,00 |





Ammortizzatore d'ormeggio «UNIMER» ad avvolgimento

«UNIMER» mooring compensator

Fabbricato in gomma EPDM resistente al salino.

Made of salt-resistant EPDM rubber.



| Articolo - Item | €/pc. | Length mm. | Per cima - For rope Ø mm. | kg. |
|-----------------|-------|------------|---------------------------|-------|
| N 35 14 002 | | 416 | 12-14 | 0,448 |
| N 35 18 003 | | 520 | 14-18 | 0,710 |
| N 35 22 004 | | 600 | 20-24 | 1,365 |



Ammortizzatore d'ormeggio «UNIMER» U-Cleat con blocco automatico della cima

«UNIMER» U-Cleat mooring compensator with rope self-locking system

Fabbricato in gomma EPDM resistente al salino.

Made of salt-resistant EPDM rubber.



| Articolo - Item | €/pc. | Length mm. | Per cima - For rope Ø mm. | kg. |
|-----------------|-------|------------|---------------------------|-------|
| N 35 12 412 | | 416 | 12-16 | 0,448 |

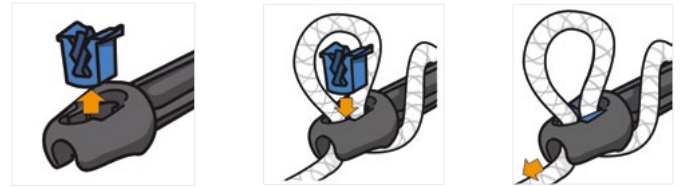

Ammortizzatore in gomma per ormeggio

Rubber mooring compensator

Fabbricato in gomma nera resistente ai raggi UV.

Made of black UV-resistant rubber.



| Articolo - Item | €/pc. | Length mm. | Per cima - For rope Ø mm. | kg. |
|-----------------|-------|------------|---------------------------|------|
| N 35 09 221 | | 420 | 10-12 | 1800 |
| N 35 09 222 | | 480 | 14-16 | 2200 |
| N 35 13 020 | | 600 | 18-20 | 3000 |



Ammortizzatore in Epdm per ormeggio

Epdm shock absorber

Ammortizzatore con estremità passacima e funzione ammortizzante garantita da 6 passanti.

Mooring compensators in Epdm rubber with high tensile strenght.



| Articolo - Item | €/pc. | Length mm. | pcs. | kg. |
|-----------------|-------|------------|------|-------|
| N 35 00 210 | | 210 | 1 | 0,290 |
| N 35 00 260 | | 260 | 1 | 0,360 |
| N 35 00 321 | | 320 | 1 | 0,670 |



Ammortizzatore accosto in rada

Shock absorber for mooring

Ideale per ormeggiare più barche accostate. Da installare con una cima di sicurezza.

Suitable for mooring of more boats together. To install with a safety line.

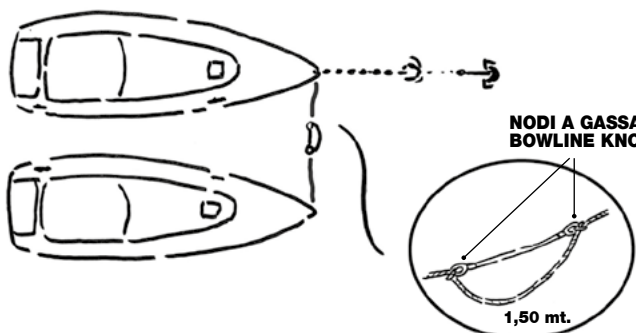

| Articolo - Item | €/pc. | Length mm. | Ø mm. | Ideale per barche Suitable for boats | kg. |
|-----------------|-------|------------|-------|--------------------------------------|-------|
| N 35 14 100 | | 1000 | 14 | <60 piedi-feet | 0,150 |



Molla per ormeggio

Le nostre molle garantiscono nel tempo le capacità ammortizzanti.
Versione in **acciaio speciale ad alta resistenza e zincato**.
Versione in **acciaio inox lucidato, ad alta resistenza**.

Shock absorber

Available high resistance galvanised steel or stainless steel.

| Articolo - Item | €/pc. | Versione - Version | Ø mm. | Length mm. | Carico max compress. Max load | Per scafi fino a mt. For boats up to mt. | Per scafi max kg. For boats max kg. | kg. |
|-----------------|-------|----------------------------------|-------|------------|-------------------------------|--|-------------------------------------|-------|
| N 35 06 033 | | Acciaio zincato-Galvanised steel | 53 | 270 | 140 | 6 | 1000 | 0,500 |
| N 35 07 033 | | Acciaio zincato-Galvanised steel | 66 | 320 | 200 | 7 | 2000 | 0,900 |
| N 35 07 350 | | Acciaio zincato-Galvanised steel | 80 | 440 | 350 | 8 | 4000 | 1,500 |
| N 35 14 250 | | Acciaio zincato-Galvanised steel | 90 | 440 | 500 | 9 | 5000 | 2,700 |
| N 35 05 027 | | Acciaio inox-Stainles steel | 50 | 270 | 95 | 5 | 1000 | 0,400 |
| N 35 07 040 | | Acciaio inox-Stainles steel | 70 | 320 | 200 | 7 | 2000 | 1,000 |
| N 35 07 036 | | Acciaio inox-Stainles steel | 85 | 420 | 250 | 9 | 3500 | 1,700 |
| N 35 11 037 | | Acciaio inox-Stainles steel | 90 | 420 | 300 | 11 | 7000 | 2,400 |
| N 35 06 034 | | Acciaio inox-Stainles steel | 55 | 320 | 110 | 6 | 1400 | 0,600 |



ACCIAIO ZINCATO GALVANISED STEEL



ACCIAIO INOX STAINLES STEEL

Molla per ormeggio in acciaio inox lucidato

Modello ad alta resistenza, **completo di piattelli anticigolio**.
Tiranti con bulloni in acciaio inox.

Shock absorber made of polished stainless steel

High resistant model, complete with inner plates for reducing of squeaking.
Tie rods with stainless steel bolts.

| Articolo - Item | €/pc. | Ø esterno mm. outer Ø mm. | Length mm. | Ø filo mm. | Per barche fino a mt. For boats up to mt. | kg. |
|-----------------|-------|---------------------------|------------|------------|---|-------|
| N 35 05 058 | | 57 | 300 | 5 | 7 | 0,600 |
| N 35 08 031 | | 60 | 360 | 6 | 7 | 0,790 |
| N 35 10 040 | | 70 | 400 | 7 | 9 | 1,430 |
| N 35 12 046 | | 85 | 470 | 9 | 11 | 2,330 |
| N 35 14 047 | | 90 | 470 | 11 | 13/14 | 3,310 |

N.B.: Da installare con una catenella di sicurezza - To be installed with a safety chain

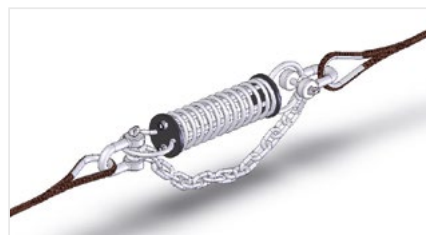

Molla per ormeggio

Shock absorber

| Articolo - Item | N 35 07 074 | N 35 08 076 | N 35 10 080 | N 35 12 090 | N 35 15 094 |
|-------------------------|-------------|-------------|-------------|-------------|-------------|
| Metri barca | 7 - 9 | 8 - 11 | 10 - 16 | 16 - 25 | 25 - 35 |
| Ø filo molla mm. | 7 | 8 | 10 | 12 | 15 |
| Ø molla mm. | 74 | 76 | 80 | 90 | 94 |
| Forza ammortizzante kg. | 200 | 250 | 470 | 750 | 1450 |
| Inserti molla flex | - | 1 | 2 - 4 | 2 - 4 | 4 |
| Carico di rottura kg. | 3000 | 4000 | 10000 | 20000 | 35000 |
| Peso - Weight (Kg.) | 1,500 | 2,500 | 3,200 | 3,500 | 4,500 |

€/pc.



N3507074



N3508076



N3510080-N3512090



N3515094

AISI 316

Musone di prua piccolo

Small bow roller

Realizzato in acciaio inox Aisi 316.

Made of Aisi 316 stainless steel.

| Articolo - Item | €/pc. | A mm. | B mm. | C mm. | L mm. | Rullo - Roller | kg. |
|-----------------|-------|-------|-------|-------|-------|----------------|-------|
| M 35 60 165 | | 155 | 101 | 70 | 50 | N3510111 | 0,430 |



SPARE PARTS

Pag. 57

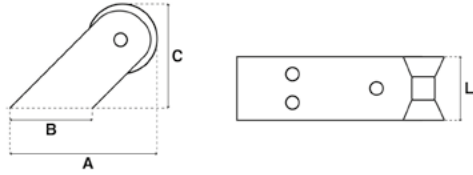

AISI 316

Musone di prua medio

Medium bow roller

Realizzato in acciaio inox Aisi 316.

Made of Aisi 316 stainless steel.

| Articolo - Item | €/pc. | A mm. | B mm. | C mm. | L mm. | Rullo - Roller | kg. |
|-----------------|-------|-------|-------|-------|-------|----------------|-------|
| N 35 10 223 | | 220 | 180 | 70 | 50 | N3510119 | 0,720 |



SPARE PARTS

Pag. 57

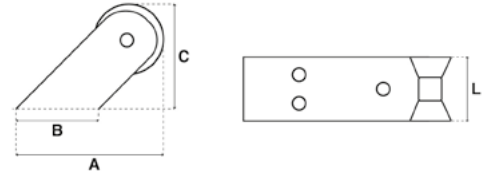

AISI 316

Musone di prua lungo

Long bow roller

Realizzato in acciaio inox Aisi 316.

Made of Aisi 316 stainless steel.

| Articolo - Item | €/pc. | A mm. | B mm. | C mm. | L mm. | D mm. | Rullo - Roller | kg. |
|-----------------|-------|-------|-------|-------|-------|-------|----------------|-------|
| N 35 10 228 | | 230 | 140 | 83 | 40 | 45 | N3510117 | 0,720 |
| N 35 10 279 | | 280 | 170 | 60 | 40 | 50 | N3510117 | 0,810 |



SPARE PARTS

Pag. 57

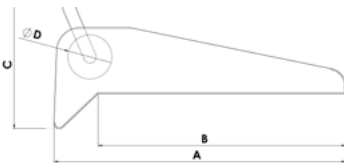

AISI 316

Musone di prua largo

Wide bow roller

Realizzato in acciaio inox Aisi 316.

Made of Aisi 316 stainless steel.

| Articolo - Item | €/pc. | A mm. | B mm. | C mm. | L mm. | D mm. | Rullo - Roller | kg. |
|-----------------|-------|-------|-------|-------|-------|-------|----------------|-------|
| N 35 10 390 | | 390 | 290 | 80 | 45 | 50 | N3101175 | 1,070 |
| N 35 10 458 | | 455 | 325 | 110 | 75 | 100 | N3510123 | 3,530 |



SPARE PARTS

Pag. 57

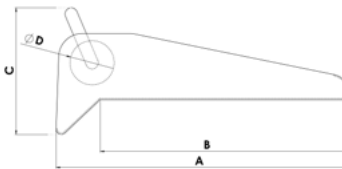

AISI 316

Musone di prua extra-large

Long bow roller

Realizzato in acciaio inox Aisi 316.

Made of Aisi 316 stainless steel.

| Articolo - Item | €/pc. | A mm. | B mm. | C mm. | L mm. | D mm. | Rullo - Roller | kg. |
|-----------------|-------|-------|-------|-------|-------|-------|----------------|-------|
| N 35 10 505 | | 500 | 370 | 80 | 60 | 110 | N3510121 | 2,900 |
| N 35 10 590 | | 590 | 460 | 85 | 85 | 130 | N3510115 | 2,810 |



SPARE PARTS

Pag. 57

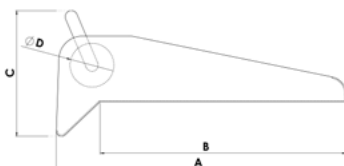

AISI 316

Musone di prua con blocca ancora

Bow roller with anchor lock

Realizzato in acciaio inox.

Made of stainless steel.

| Articolo - Item | €/pc. | A mm. | B mm. | C mm. | L mm. | Rullo - Roller | kg. |
|-----------------|-------|-------|-------|-------|-------|----------------|-------|
| N 35 90 240 | | 275 | 180 | 80 | 60 | N3501087 | 1,600 |



SPARE PARTS

Pag. 57

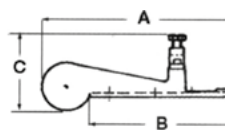
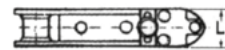

AISI 316

Musone di prua fisso

Realizzato in acciaio inox lucidato completo di puleggia in nylon.

Steady bow roller

Made of polished stainless steel. With nylon pulley.

| Articolo - Item | €/pc. | A mm. | B mm. | C mm. | L mm. | Rullo - Roller | kg. |
|-----------------|-------|-------|-------|-------|-------|----------------|-------|
| N 35 01 523 | 242 | 147 | 78 | 67 | | N3501087 | 1,800 |
| N 35 01 524 | 326 | 222 | 85 | 65 | | N3501087 | 2,300 |



SPARE PARTS

Pag. 57

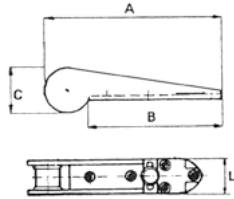

AISI 316

Musone di prua indicato per ancore tipo «Bruce» e «Rhino»

Fabbricato in acciaio inox lucidato. Completo di puleggia flottante in nylon.

Bow roller suitable for anchors «Bruce» and «Rhino»

Manufactured in polished stainless steel. With nylon pulley.

| Articolo - Item | €/pc. | A mm. | B mm. | C mm. | L mm. | Rullo - Roller | kg. |
|-----------------|-------|-------|-------|-------|-------|----------------|-------|
| N 35 01 540 | 373 | 250 | 187 | 63 | | N3501082 | 6,000 |
| N 35 50 221 | 542 | 380 | 250 | 85 | | N3501082 | 8,700 |



SPARE PARTS

Pag. 57

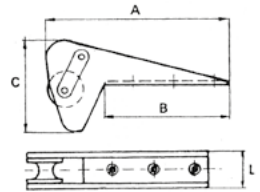

AISI 316

Musone di prua a ribalta

Fabbricato in acciaio inox lucidato. Completo di puleggia flottante in nylon.

Folding bow roller

Manufactured in polished stainless steel. With nylon pulley.

| Articolo - Item | €/pc. | A mm. | B mm. | C mm. | L mm. | Per ancore Anchors max kg. | Rullo Roller | kg. |
|-----------------|-------|-------|-------|-------|-------|----------------------------|----------------------|-------|
| N 35 01 542 | 390 | 300 | 190 | 80 | | 10 | N3501083 N3501084 | 4,000 |



SPARE PARTS

Pag. 57

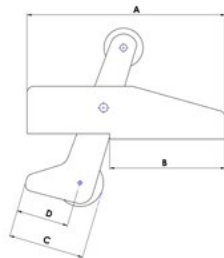

AISI 316

Musone di prua indicato per ancore in acciaio inox Aisi 316

Fabbricato in acciaio inox Aisi 316.

Bow roller in Aisi 316 stainless steel

Manufactured in Aisi 316 stainless steel.

| Articolo - Item | €/pc. | A mm. | B mm. | C mm. | L mm. | Per ancore Anchors max kg. | Rullo Roller | kg. |
|-----------------|-------|-------|-------|-------|-------|----------------------------|----------------------|-------|
| N 35 06 070 | 330 | 185 | 75 | 50 | | 5-8 | N3586125 N3561125 | 1,640 |
| N 35 70 320 | 400 | 230 | 100 | 80 | | 10-12 | N3501083 N3501084 | 7,000 |



SPARE PARTS

Pag. 57

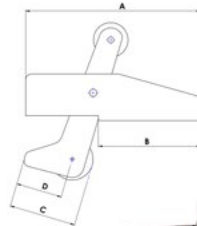
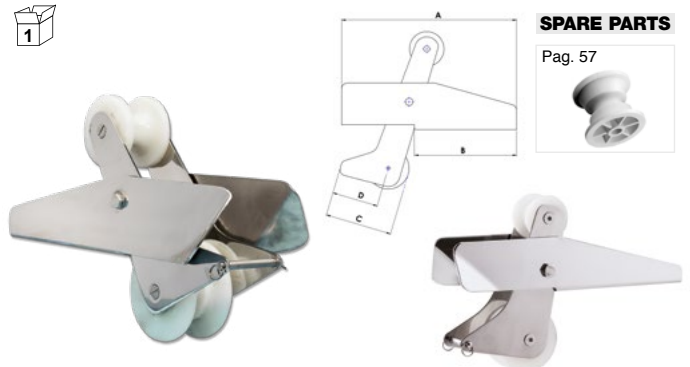

AISI 316

Musone di prua

Realizzato in acciaio inox Aisi 316 microfuso.

Bow roller

Made of casted Aisi 316 stainless steel.

| Articolo - Item | €/pc. | Mod. | A mm. | B mm. | C mm. | L mm. | Rullo Roller | kg. |
|-----------------|-------|------|-------|-------|-------|-------|--------------|-------|
| N 35 20 155 | | A | 205 | 105 | 160 | 75 | N3541084 | 2,400 |
| N 35 34 160 | | B | 340 | 242 | 160 | 75 | N3541084 | 3,200 |



N3520155



N3534160

SPARE PARTS

Pag. 57

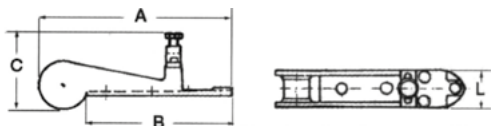

AISI 316

Musone di prua

Realizzato in acciaio inox Aisi 316.

Bow roller

Made of Aisi 316 stainless steel.

| Articolo - Item | €/pc. | A mm. | B mm. | C mm. | L mm. | Per ancore Anchors max kg. | Rullo Roller | kg. |
|-----------------|-------|-------|-------|-------|-------|----------------------------|--------------|-------|
| N 35 10 510 | 300 | 155 | 80 | 75 | | 10 | | 1,330 |
| N 35 20 511 | 400 | 250 | 80 | 75 | | 15 | | 1,700 |
| N 35 25 512 | 500 | 360 | 80 | 75 | | 20 | | 2,300 |

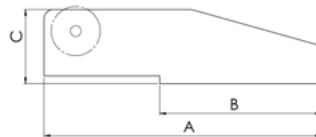

N3510510



N3520511



N3525512

AISI 316

Musone di prua

Realizzato in acciaio inox Aisi 316 microfuso.

Bow roller

Made of casted Aisi 316 stainless steel.

| Articolo - Item | €/pc. | A mm. | B mm. | C mm. | L mm. | Rullo - Roller | kg. |
|-----------------|-------|-------|-------|-------|-------|----------------|-------|
| N 35 52 155 | | 165 | 90 | 75 | 60 | N3510111 | 0,650 |

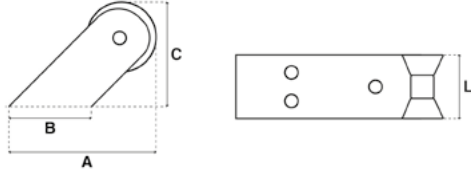

SPARE PARTS

Pag. 57



AISI 316

Dispositivo di ormeggio e ritenuta ancora

Realizzato in acciaio inox Aisi 316.

Mooring device with anchor chain lock

Made of Aisi 316 stainless steel.

| Articolo - Item | €/pc. | Catena-Chain Ø mm. | kg. |
|-----------------|-------|--------------------|-------|
| N 35 08 603 | | 6-8 | 0,320 |



AISI 316

Musone di prua autobloccante Self-locking bow roller

Realizzato in acciaio inox Aisi 316.

Made of Aisi 316 stainless steel.

| Articolo - Item | €/pc. | A mm. | B mm. | C mm. | L mm. | D mm. | Rullo - Roller | kg. |
|-----------------|-------|-------|-------|-------|-------|-------|----------------|-------|
| N 35 64 242 | 416 | 230 | 120 | 80 | 80 | | N3560113 | 3,500 |

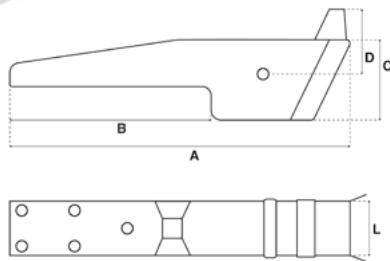
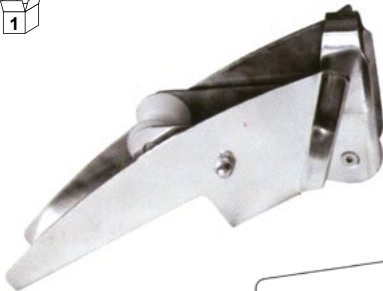

SPARE PARTS

Pag. 57



AISI 316

Passacavo di prua

Realizzato in acciaio inox Aisi 316 microfuso.

Bow fairlead

Made of casted Aisi 316 stainless steel.

| Articolo - Item | €/pc. | Length mm. | mm. | kg. |
|-----------------|-------|------------|---------|-------|
| N 35 14 209 | | 130 | 90 x 90 | 1,090 |



AISI 316

Musone di prua per piattaforma

Realizzato in acciaio inox Aisi 304.

Platform bow roller

Made of Aisi 304 stainless steel.

| Articolo - Item | €/pc. | A mm. | B mm. | C mm. | L mm. | Ø mm. | Rullo - Roller | kg. |
|-----------------|-------|-------|-------|-------|-------|-------|----------------|-------|
| N 35 75 150 | | 150 | 75 | - | - | - | - | 0,950 |
| N 35 60 004 | | 185 | 75 | 160 | 85 | 75 | N3510115 | 0,950 |
| N 35 60 005 | | 150 | 75 | 155 | 45 | 60 | N3510117 | 0,600 |

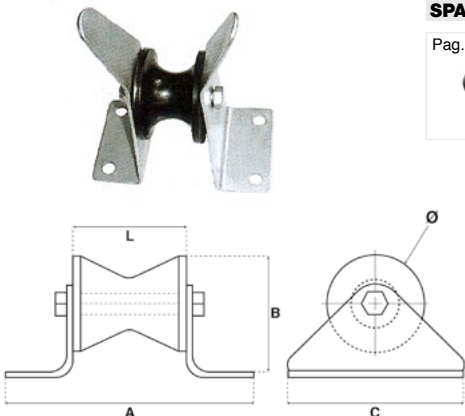

SPARE PARTS

Pag. 57



AISI 316

Passacavo di poppa a rulli

Realizzato in acciaio inox Aisi 304.

Stern fairlead anchor roller

Made of Aisi 304 stainless steel.

| Articolo - Item | €/pc. | mm. | Per cime For lines Ø mm. | Rullo Roller | kg. |
|-----------------|-------|--------|--------------------------|--------------|-------|
| N 39 22 160 | | 160x87 | 22 | N3510131 | 0,630 |



SPARE PARTS

Pag. 57



AISI 316

Musone di prua

Realizzato in acciaio fuso Aisi 316.
Con puleggia in nylon.

Bow roller

Made of casted Aisi 316 stainless steel.
With nylon pulley.

| Articolo - Item | €/pc. | A mm. | B mm. | C mm. | L mm. | D mm. | Per ancore Anchors max kg. | Rullo Roller | kg. |
|-----------------|-------|-------|-------|-------|-------|-------|----------------------------|--------------|-------|
| N 35 10 403 | | 670 | 340 | 200 | 65 | 160 | 8 | N3510129 | 13,30 |
| N 35 25 404 | | 670 | 340 | 200 | 65 | 210 | 20 | - | 13,60 |



SPARE PARTS

Pag. 57

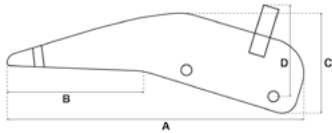
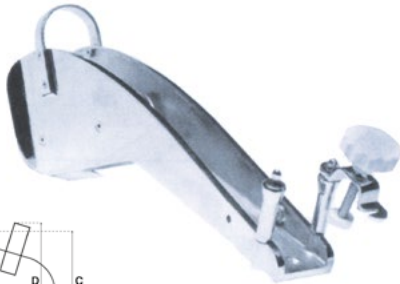

AISI 316

Musone adatto ad ancore tipo aratro «Bruce» - «CQR»

Fabbricato in acciaio inox.

Bow roller for anchors type «Bruce» - «CQR»

Manufactured in stainless steel.

| Articolo - Item | €/pc. | A mm. | B mm. | C mm. | Spessore Depth mm. | Ancora Anchor Kg. | Rullo Roller | kg. |
|-----------------|-------|-------|-------|-------|--------------------|-------------------|----------------------|-------|
| N 35 10 330 | | 330 | 70 | 180 | 4 | 10 | N3501526 | 3,000 |
| N 35 15 400 | | 400 | 70 | 195 | 4 | 15 | N3501526 | 4,500 |
| N 35 20 495 | | 495 | 70 | 150 | 3 | 20 | N3501527 N3501528 | 6,500 |



SPARE PARTS

Pag. 57

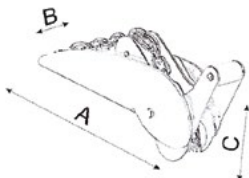

AISI 316

Musone autobloccante per ancore tipo «Bruce»

Fabbricato in acciaio inox Aisi 316.
Completo di cavallotto di sicurezza e di puleggia inox indistruttibile.

Self-locking bow roller for «Bruce» type anchors

Made of AISI 316 stainless steel.
Unbreakable stainless steel sheave, fitted with safety anchor stopper.

| Articolo - Item | €/pc. | A mm. | B mm. | C mm. | L mm. | D mm. | Per ancore Anchors kg. | Per catene For Chain kg. | Rullo Roller | kg. |
|-----------------|-------|-------|-------|-------|-------|-------|------------------------|--------------------------|--------------|--------|
| N 35 10 201 | | 385 | 260 | 190 | 50 | 150 | 10 | 6/8 | N3566127 | 4,360 |
| N 35 20 203 | | 540 | 300 | 240 | 60 | 150 | 20 | 10/12 | N3510129 | 10,000 |
| N 35 30 204 | | 540 | 300 | 240 | 70 | 210 | 30 | - | N3510129 | 10,000 |



SPARE PARTS

Pag. 57

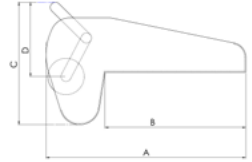

AISI 316

Musone universale adatto a tutti i tipi di ancore leggere

Fabbricato in acciaio inox.

Bow roller for light anchors

Manufactured in stainless steel.

| Articolo - Item | €/pc. | A mm. | B mm. | C mm. | Spessore Depth mm. | Ancora Anchor Kg. | Rullo Roller | kg. |
|-----------------|-------|-------|-------|-------|--------------------|-------------------|--------------|-------|
| N 35 07 150 | | 150 | 54 | 80 | 2 | 7,5 | N3501526 | 0,370 |
| N 35 10 250 | | 250 | 54 | 80 | 2 | 10 | N3501526 | 0,590 |

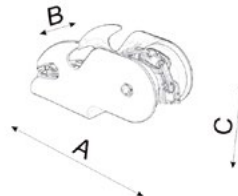
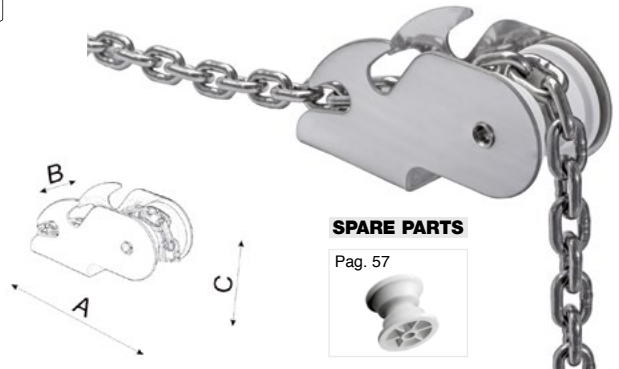

SPARE PARTS

Pag. 57



MUSONI OTTONE | BRASS BOW ROLLERS

AISI 316

Musone di prua

Realizzato in acciaio fuso Aisi 316.

Bow roller

Made of Aisi 316 casted stainless steel.

| Articolo - Item | €/pc. | A mm. | B mm. | C mm. | L mm. | D mm. | Per ancore Anchors max kg. | Rullo Roller | kg. |
|-----------------|-------|-------|-------|-------|-------|-------|----------------------------|--------------|--------|
| N 35 12 406 | | 410 | 160 | 110 | 65 | 100 | 12 | N3566127 | 7,200 |
| N 35 20 408 | | 540 | 230 | 120 | 80 | 100 | 12 | N3518127 | 11,000 |



SPARE PARTS

Pag. 57

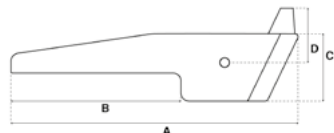
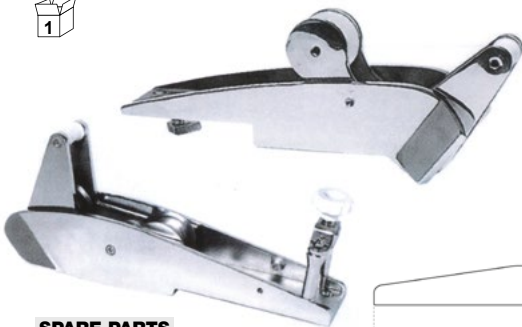

Musone di prua

Realizzato in ottone cromato.

Bow roller

Made of chromed brass.

| Articolo - Item | €/pc. | Length mm. | Rullo - Roller Ø mm. | kg. |
|-----------------|-------|------------|----------------------|-------|
| N 35 14 025 | | 145 | 25 | 0,600 |
| N 35 16 038 | | 160 | 38 | 0,800 |



MUSONI DI PRUA IN ALLUMINIO | ALUMINIUM BOW ROLLERS

Musone di prua con sistema «Stop & Lock»

Realizzato in alluminio anodizzato.

Bow roller with «Stop & Lock» system

Made of anodised aluminium.

| Articolo - Item | €/pc. | A mm. | B mm. | C mm. | L mm. | Per ancore Anchors max kg. | Rullo Roller | kg. |
|-----------------|-------|-------|-------|-------|-------|----------------------------|--------------|-------|
| N 35 75 205 | | 205 | 105 | 160 | 75 | 10 | N3510107 | 0,500 |
| N 35 75 340 | | 340 | 242 | 160 | 75 | 10 | N3510107 | 2,000 |

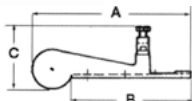

SPARE PARTS

Pag. 57



Musone di prua a ribalta

Realizzato in alluminio anodizzato.

Folding bow roller

Made of anodised aluminium.

| Articolo - Item | €/pc. | A mm. | B mm. | D mm. | E mm. | L mm. | Per ancore Anchors max kg. | Rullo Roller | kg. |
|-----------------|-------|-------|-------|-------|-------|-------|----------------------------|--------------|-------|
| N 35 50 020 | | 365 | 205 | 60 | 13 | 88 | 12 | N3510135 | 3,000 |
| N 35 15 410 | | 410 | 160 | 62 | 25 | 95 | 15 | N3510107 | 3,950 |

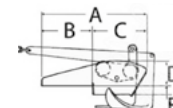

SPARE PARTS

Pag. 57



Musone di prua

Realizzato in alluminio anodizzato.

Bow roller

Made of anodised aluminium.

| Articolo - Item | €/pc. | A mm. | B mm. | C mm. | L mm. | Per ancore Anchors max kg. | Rullo Roller | kg. |
|-----------------|-------|-------|-------|-------|-------|----------------------------|--------------|-------|
| N 35 10 380 | | 380 | 261 | 196 | 67 | 10 | N3510107 | 2,000 |
| N 35 30 592 | | 592 | 345 | 235 | 92 | 30 | N3510108 | 7,000 |

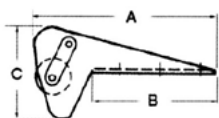

SPARE PARTS

Pag. 57



Carrucola svolgicatenata o svolgi-cima da applicare alla battagliola

Indicata per tubo Ø 22 - 25 mm. Pratico rullo applicabile sul tubo della battagliola. Fabbricata completa di viti per il fissaggio e di boccia di riduzione.

Chain or line unwinding pulley for guardrail

Suitable for pipe Ø 22 - 25 mm. Roller to be fitted on the guardrail pipe. Supplied with fixing screws and bushing.

| Articolo - Item | €/pc. | Adatta per tubo For pipe Ø mm. | Carrucola Pulley Ø mm. | kg. |
|-----------------|-------|--------------------------------|------------------------|-------|
| N 03 25 040 | | 22 - 25 | 40 | 0,205 |

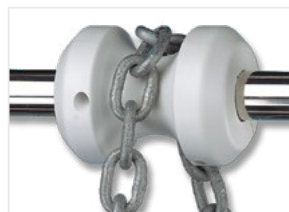

Gancio fermacatenata o fermacima per battagliola

Indicato per fermare l'ancora in posizione di riposo.

Chain and line stopper device for guardrail

To stop the anchor chain.

| Articolo - Item | €/pc. | Adatta per tubo For pipe Ø mm. | kg. |
|-----------------|-------|--------------------------------|-------|
| N 03 22 025 | | 22 - 25 | 0,030 |

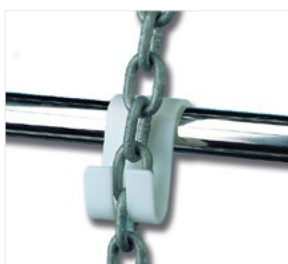

CUBIE | HAWSEHOLES

AISI 316

Cubia ovale

In acciaio inox Aisi 316 lucidato a specchio. Privo di controflangia.

Oval hawsehole

In Aisi 316 polished stainless steel. Without counter flange.

| Articolo - Item | €/pc. | mm. (Ext.) | mm. (Int.) | Controflangia Counterflange | Collo max mm. |
|-----------------|-------|------------|------------|-----------------------------|---------------|
| N 39 68 004 | | 140x63 | 97x37 | NO | 22 |



NEW

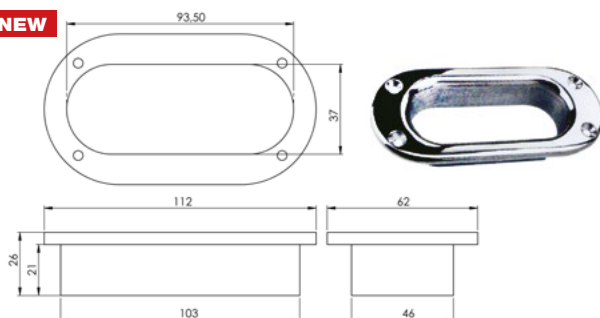

AISI 316

Cubia a rulli

In acciaio inox Aisi 316 lucidato a specchio. Completa di controflangia. Il collo può essere tagliato fino alla misura desiderata.

Roller hawsehole

In Aisi 316 polished stainless steel. Complete with trimming ring. The hull thickness can be cut at any required size.

| Articolo - Item | €/pc. | A mm. | B mm. | C mm. | D mm. | Taglio-Cut mm. | Collo mm. | Prigionieri mm. | kg. |
|-----------------|-------|-------|-------|-------|-------|----------------|-----------|-----------------|-------|
| N 39 09 001 | | 340 | 160 | 270 | 91 | 280x100 | 125 | 8 | 7,900 |



NEW

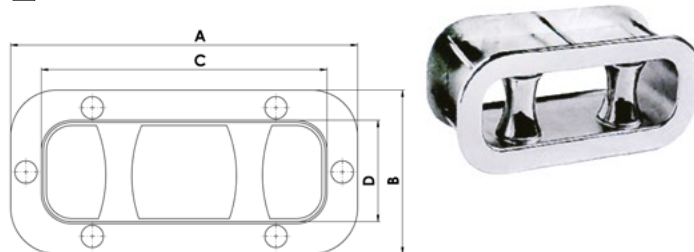

Puleggia di ricambio

Spare pulley

| Articolo - Item | €/pc. | Ø mm. | H mm. | Montata su musoni-Fitted on bow rollers |  | Materiale-Material |
|------------------------|-------|-------|-------|---|---|--------------------|
| N 35 10 107 NEW | | 68 | 41 | N3575205-N3575340 N3515410-N3510380 | 1 | Nylon |
| N 35 10 135 NEW | | 68 | 36 | N3550020 | 1 | Nylon |
| N 35 10 136 NEW | | 30 | 37 | N3550020-N3515410 | 1 | Nylon |
| N 35 10 108 NEW | | 87 | 50 | N3530592 | 1 | Nylon |
| N 35 10 111 NEW | | 42 | 54 | N3552155-M3560165 | 1 | Nylon |
| N 35 60 113 NEW | | 60 | 55 | N3564242 | 1 | Nylon |
| N 35 52 113 NEW | | 52 | 55 | N3564242 | 1 | Nylon |
| N 35 10 115 NEW | | 76,2 | 85,8 | N3560004-N3510590 | 1 | Nylon |
| N 35 10 117 NEW | | 63 | 42,8 | N3560005-N3510228 N3510279-N3510390 | 1 | Nylon |
| N 35 10 119 NEW | | 50 | 50 | N3510223 | 1 | Nylon |
| N 35 10 121 NEW | | 67,8 | 60 | N3510505 | 1 | Nylon |
| N 35 10 123 NEW | | 74 | 71 | N3510458 | 1 | Nylon |
| N 35 86 125 NEW | | 86 | 49 | N3506070 | 1 | Nylon |
| N 35 61 125 NEW | | 61 | 49 | N3506070 | 1 | Nylon |
| N 35 66 127 NEW | | 66 | 40 | N3512406-N3510201 | 1 | Nylon |
| N 35 18 127 NEW | | 18 | 30 | N3520408 | 1 | Nylon |
| N 35 10 129 NEW | | 100 | 56 | N3510403-N3510404 N3520203-N3530204 | 1 | Nylon |
| N 35 10 131 NEW | | 62/51 | 43 | N3922160 | 1 | Nylon |
| N 35 10 133 NEW | | 30 | 35 | N3514209 | 1 | Nylon |
| N 35 01 087 NEW | | 67 | 50 | N3590240-N3501523 N3501524 | 1 | Nylon |
| N 35 01 082 NEW | | 80 | 70 | N3501540-N3550221 | 1 | Nylon |
| N 35 01 083 NEW | | 50 | 55 | N3501542-N3570320 | 1 | Nylon |
| N 35 01 084 NEW | | 50 | 55 | N3501542-N3570320 | 1 | Nylon |
| N 35 01 526 | | 54 | 48 | N3510330-N3515400-N3507150 N3510250 | 1 | Nylon |
| N 35 01 527 | | 54 | 62 | N3520495 | 1 | Nylon |
| N 35 01 528 | | 70 | 62 | N3520495 | 1 | Nylon |
| N 35 41 084 NEW | | 68 | 71 | N3520155-N3534160 | 1 | Alluminio-Alu |



AISI 316 CALIBRATA

Catena a maglia calibrata in acciaio inox Aisi 316 per argani e salpancore

Calibrated chain in Aisi 316 stainless steel for windlasses

| Articolo - Item 25 mt. | €/mt. | €/kg | Articolo - Item 50 mt. | €/mt. | €/kg | Filo-Wire Ø mm. | Carico di rottura Breaking Load Kg. | Norme Rules | mm. | kg. |
|---------------------------|-------|------|---------------------------|-------|------|--------------------|--|----------------|-------------|--------|
| N 03 06 025 | | | N 03 06 050 | | | 6 | 1630 | DIN766/ISO | 18,5 x Ø 20 | 40,00 |
| N 03 08 025 | | | N 03 08 050 | | | 8 | 3200 | DIN766/ISO | 24 x Ø 26 | 70,00 |
| N 03 10 025 | | | N 03 10 050 | | | 10 | 5000 | ISO | 30 x Ø 35 | 110,00 |



CALIBRATA

Catena a maglia calibrata in acciaio «Zincata a fuoco» per argani e salpancore - Din 766A

Calibrated chain hot dip galvanised for use with a windlass - Din 766 A

| Articolo - Item | €/mt. | €/kg | Filo-Wire Ø mm. | mm. | mt. | kg. |
|-----------------|-------|------|-----------------|-----------|-----|--------|
| N 03 06 101 M | | | 6 | 20 x 18,5 | 50 | 40,00 |
| N 03 08 151 M | | | 8 | 27 x 24 | 50 | 70,00 |
| N 03 10 150 M | | | 10 | 36 x 28 | 50 | 110,00 |



GENOVESE

Catena a maglia genovese in acciaio «Zincata a fuoco» per ancoraggio - ISO 1416 (passo corto)

Chain hot dip galvanised for use with a windlass - ISO 1416

| Articolo - Item | €/mt. | €/kg | Filo-Wire Ø mm. | mm. | mt. | kg. |
|-----------------|-------|------|-----------------|-----------|-----|--------|
| N 03 06 001 M | | | 6 | 23 x 24,5 | 50 | 36,50 |
| N 03 08 001 M | | | 8 | 31 x 35 | 50 | 65,00 |
| N 03 10 001 M | | | 10 | 40 x 40 | 50 | 102,50 |
| N 03 20 001 M | | | 20 | 85 x 40 | 50 | 410,00 |



GENOVESE

Catena genovese in acciaio «Zincata a fuoco» completa di grillo

Chain hot dip galvanised with shackle

Tratti di catena in dimensioni indicate per l'ancoraggio. Confezione 5 metri con grillo.

Suitable for mooring. Packing 5 mt. with shackle.

| Articolo - Item | €/kg | 5 mt. | Catena-Chain Ø mm. | mt. | kg. |
|-----------------|------|-------|--------------------|-----|------|
| N 03 06 005 | | | 6 | 5 | 3,90 |



False maglie di giunzione acciaio zincato mod. ad incastro per catene

Galvanised chain quicklink

Particolarmente robuste.

Particularly strong.

| Articolo - Item | €/ pc. | Ø mm. | H mm. | Length mm. | kg. |
|-----------------|--------|-------|-------|------------|-------|
| M 13 06 030 | | 6 | 39 | 26 | 0,100 |
| M 13 08 040 | | 8 | 45 | 31 | 0,150 |
| M 13 10 130 | | 10 | 54 | 35,5 | 0,180 |



«Segnacatena Colorato»

«Chain rainbow»

Dispositivo segnacatena, costituito da inserti in plastica colorati da incastrare nelle maglie della catena. Venduto in kit atto a marcare 25 cm. di catena calibrata.

Coloured plastic inserts for fitting into chain links, sold in kits suitable for marking 25 cm of sized chains.

| Colore Colour | Articolo - Item Ø 6 | €/box | kg. | Articolo - Item Ø 8 | €/box | kg. |
|------------------|------------------------|-------|-------|------------------------|-------|-------|
| ■ | N 02 06 085 | 14 | 0,010 | N 02 08 085 | 10 | 0,020 |
| ■ | N 02 06 082 | 14 | 0,010 | N 02 08 082 | 10 | 0,020 |
| ■ | N 02 06 077 | 14 | 0,010 | N 02 08 077 | 10 | 0,020 |
| ■ | N 02 06 074 | 14 | 0,010 | N 02 08 074 | 10 | 0,020 |
| ■ | N 02 06 075 | 14 | 0,010 | N 02 08 075 | 10 | 0,020 |

| Colore Colour | Articolo - Item Ø 10 | €/box | kg. | Articolo - Item Ø 12 | €/box | kg. |
|------------------|-------------------------|-------|-------|-------------------------|-------|-------|
| ■ | N 02 10 085 | 8 | 0,030 | N 02 12 085 | 8 | 0,040 |
| ■ | N 02 10 082 | 8 | 0,030 | N 02 12 082 | 8 | 0,040 |
| ■ | N 02 10 077 | 8 | 0,030 | N 02 12 077 | 8 | 0,040 |
| ■ | N 02 10 074 | 8 | 0,030 | N 02 12 074 | 8 | 0,040 |
| ■ | N 02 10 075 | 8 | 0,030 | N 02 12 075 | 8 | 0,040 |

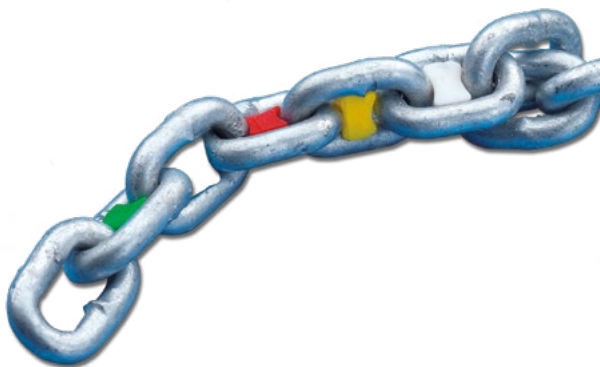

AISI 316

Giunto salpancora girevole Swivel anchor chain

Realizzato in acciaio inox Aisi 316. Made of Aisi 316 stainless steel.

| Articolo - Item | €/pc. | A mm. | B mm. | L mm. | D mm. | D1 mm. | Catena-Chain Ø mm. | kg. |
|-----------------|-------|-------|-------|-------|-------|--------|-----------------------|-------|
| M 13 08 002 | | 10 | 15 | 90 | 7 | 9 | 6 - 8 | 0,250 |
| M 13 10 022 | | 14 | 22 | 115 | 10,5 | 10,5 | 10 - 12 | 0,560 |

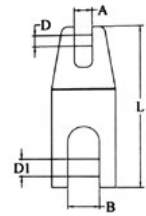

AISI 316

Giunto salpancora girevole doppio Double swivel anchor chain

Realizzato in acciaio inox Aisi 316. Made of Aisi 316 stainless steel.

| Articolo - Item | €/pc. | A mm. | B mm. | L mm. | D mm. | D1 mm. | Catena-Chain Ø mm. | kg. |
|-----------------|-------|-------|-------|-------|-------|--------|-----------------------|-------|
| M 13 08 004 | | 10 | 15 | 116 | 7 | 9 | 6 - 8 | 0,350 |
| M 13 10 004 | | 14 | 18 | 165 | 10,5 | 10,5 | 10 - 12 | 0,880 |

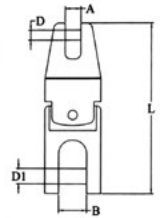

AISI 316

Giunto salpancora girevole doppio Double swivel anchor chain

Realizzato in acciaio inox Aisi 316. Made of Aisi 316 stainless steel.

| Articolo - Item | €/pc. | W1/W2 mm. | W3 mm. | L mm. | L1 mm. | D mm. | Catena-Chain Ø mm. | pc. | kg. |
|-----------------|-------|--------------|-----------|----------|-----------|----------|-----------------------|-----|-------|
| M 13 08 810 | | 11 | 28 | 220 | 10 | 7 | 6 - 8 | 30 | 0,980 |
| M 13 12 812 | | 13 | 38 | 300 | 14 | 10,5 | 10 - 12 | 10 | 2,550 |

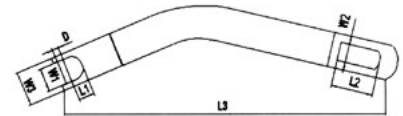

GIRELLE | SWIVELS

AISI 316

Girella, occhio-occhio Swivel, Eye&Eye

Realizzata in acciaio inox Aisi 316. Made of Aisi 316 stainless steel.

| Articolo - Item | €/pc. | D Ø mm. | L mm. | W mm. | kg. |
|-----------------|-------|---------|-------|-------|-------|
| M 03 06 065 | | 6 | 65 | 15 | 0,050 |
| M 03 08 090 | | 8 | 90 | 20 | 0,120 |
| M 03 10 105 | | 10 | 115 | 24 | 0,240 |

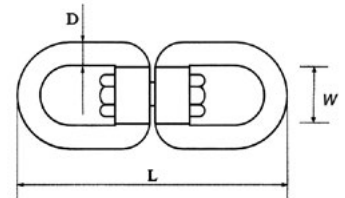

AISI 316

Girella, occhio-grillo Swivel, Eye&Jaw

Realizzata in acciaio inox Aisi 316. Made of Aisi 316 stainless steel.

| Articolo - Item | €/pc. | D Ø mm. | L mm. | W mm. | kg. |
|-----------------|-------|---------|-------|-------|-------|
| M 03 08 085 | | 8 | 94 | 16 | 0,140 |
| M 03 10 100 | | 10 | 118 | 20 | 0,270 |

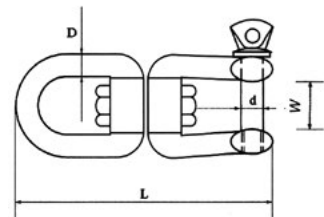

AISI 316

Girella, grillo-grillo Swivel, Jaw&Jaw

Realizzata in acciaio inox Aisi 316. Made of Aisi 316 stainless steel.

| Articolo - Item | €/pc. | D Ø mm. | L mm. | W mm. | kg. |
|-----------------|-------|---------|-------|-------|-------|
| M 43 06 060 | | 6 | 66 | 12 | 0,070 |
| M 43 08 085 | | 8 | 94 | 16 | 0,150 |
| M 43 10 100 | | 10 | 118 | 20 | 0,300 |

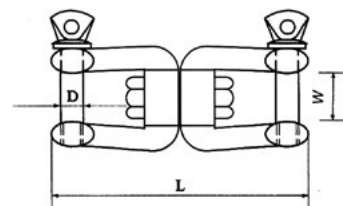
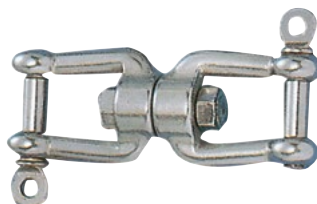



**Coppia di passacavi
assimetrici in nylon**

Fabbricati in nylon di prima qualità.
Particolarmente resistente.
Fissaggio tramite vite. Colore nero.

**Pair of black colour nylon
fairleads**

Made of strong nylon material.
High resistance. Fastening by screws.
Black colour.

| Articolo - Item | €/Paio - Pair | €/5 pairs | Length mm. | Pollici - Size" | kg. |
|-----------------|---------------|-----------|------------|-----------------|-------|
| N 39 02 120 | | | 120 | 60 | 0,100 |
| N 39 02 150 | | | 150 | 140 | 0,150 |



**Bitta a galloccia in nylon nero
e bianco**

**White and black colour
open base cleat**

| Articolo - Item | €/pc. | €/box | Articolo - Item | €/pc. | €/box | tot. mm. | Interasse fori Length Hole wheelbase mm. | kg. |
|-----------------|-------|-------|-----------------|-------|-------|----------|--|-----|
| N 31 00 060 | | | N 32 00 060 | | | 60 | 20 | 10 |
| N 31 00 080 | | | N 32 00 080 | | | 80 | 21 | 10 |
| N 31 00 110 | | | N 32 00 110 | | | 110 | 30 | 10 |
| N 31 00 145 | | | N 32 00 145 | | | 140 | 38 | 10 |
| N 31 00 180 | | | N 32 00 180 | | | 165 | 41 | 10 |
| N 31 00 198 | | | N 32 00 198 | | | 200 | 48 | 10 |
| N 31 00 210 | | | N 32 00 210 | | | 225 | 52 | 10 |



Bitta a strozza in nylon nero

Fabbricata in nylon di prima qualità.
Particolarmente resistente.
Fissaggio tramite due viti. Colore nero.

**Black colour nylon jib sheet
cleat**

Made of strong nylon material.
Fastening by two screws.
Black colour.

| Articolo - Item | €/pc. | €/box | Length mm. | Per scotte For sheets Ø mm. | kg. |
|-----------------|-------|-------|---------------|--------------------------------|-------|
| N 31 01 150 | | | 150 | 8-16 | 0,750 |

ACCESSORI ORMEGGIO | MOORING ACCESSORIES



Maniglia leva-drappe

Consente di levare facilmente gli ormeggi senza bagnarsi o sporcarsi durante le operazioni in porto.

Mooring handle

Very useful device for easy and clean mooring.

| Articolo - Item | €/pc. | mm. | kg. |
|-----------------|-------|-----------|-------|
| R 09 00 140 | | 140 x 320 | 1,200 |



AISI 316

Arrotolatore cinghia

Fabbricato in acciaio inox Aisi 316.
Cinghia colore bianco.
Larghezza cinghia 25 mm.
Diametro morsetto 25/30 mm.

Roller for «Safety Line»

Made of Aisi 316 stainless steel with belt.
Belt width 25 mm.
Clamp Ø 25/30 mm.

| Articolo - Item | €/pc. | Mod. | Cinghia-Belt kg. | kg. |
|-----------------|-------|--------------------------------|------------------|-------|
| N 05 42 030 | | con cinghia - with belt 30 mt. | 2000 | 2,560 |



AISI 316

Bitta abbattibile

Fabbricata in acciaio inox Aisi 316 lucidato a specchio. Non richiede incasso.

Folding cleat

Made of mirror polished Aisi 316 stainless steel. No recess fit required.

| Articolo - Item | €/pc. | Fissaggio Mounting | Length mm. | H mm. | Interasse mm. | kg. |
|-----------------|-------|------------------------------------|------------|-------|---------------|-------|
| N 30 52 616 | | Prigionieri Ø 8x45 mm. (included) | 143 | 53 | 92 | 0,420 |
| N 30 52 618 | | Prigionieri Ø 10x50 mm. (included) | 210 | 70 | 137 | 1,200 |
| N 30 52 606 | | Viti - Screws (not included) | 143 | 53 | 92 | 0,420 |
| N 30 52 608 | | Viti - Screws (not included) | 210 | 70 | 137 | 1,100 |



AISI 316

Bitta abbattibile apertura a pulsante

Realizzata in fusione Aisi 316. Elettrolucidata chimicamente, montaggio mediante prigionieri. Apertura mediante pulsante.

Folding cleat with push button

Highly polished. In stainless steel. Mounting by screws. Push button opening system.

| Articolo - Item | €/pc. | A mm. | B mm. | C mm. | D mm. | E Ø mm. | kg. |
|-----------------|-------|-------|-------|-------|-------|---------|-------|
| N 30 08 155 | | 155 | 54 | 13,5 | 85,5 | M8 x 38 | 0,800 |

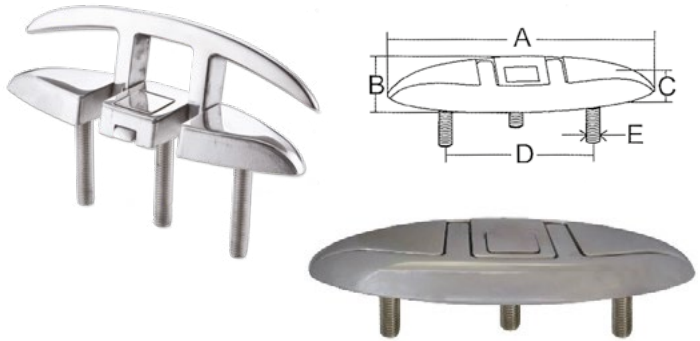

AISI 316

Bitta a scomparsa microfusa

Fabbricata in acciaio inox Aisi 316 lucidato a specchio. Completa di prigionieri di fissaggio e contropiastra di rinforzo.

Retractable cleat

Made of mirror-polished Aisi 316 stainless steel. Complete with mounting studs and retainer plate.

| Articolo - Item | €/pc. | Length mm. | | H mm. | Sporgenza mm. | | | Prigionieri Ø mm. | kg. |
|-----------------|-------|------------|-----|-------|---------------|----|----|------------------------|-------|
| | | A | A1 | | B | D | C | | |
| N 31 16 150 | | 164 | 150 | 38 | 12 | 60 | 23 | 10 (included) | 0,620 |
| N 31 25 190 | | 217 | 203 | 50 | 15 | 83 | 36 | 10 (included) | 1,130 |
| N 31 12 300 | | 305 | 285 | 70 | 25 | 95 | 52 | 12 (optional N3012100) | 3,200 |



SUGGESTED ITEMS

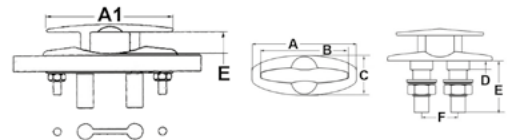

AISI 316

Bitta a scomparsa

Fabbricata in acciaio inox Aisi 316 lucidato a specchio. Completa di ferramenta e condotto di drenaggio.

Retractable cleat

Made of mirror-polished Aisi 316 stainless steel. Complete with hardware and drainer kit.

| Articolo - Item | €/pc. | A mm. | B mm. | C mm. | D mm. | E mm. | F mm. | kg. |
|-----------------|-------|-------|-------|-------|-------|-------|-------|-------|
| N 31 53 115 | | 125 | 110 | 33 | 10 | 60 | 48 | 0,580 |
| N 31 53 150 | | 155 | 140 | 37 | 12 | 70 | 60 | 0,700 |



AISI 316

Mini bitta a scomparsa

Fabbricata in acciaio inox Aisi 316 lucidato a specchio. Ideale per aggancio parabordi, tender o piccole imbarcazioni.

Retractable mini-cleat

Made of mirror-polished Aisi 316 stainless steel. Suitable for coupling fenders, dinghies or small boats.

| Articolo - Item | €/pc. | Base mm. | Foro - Hole Ø mm. | kg. |
|-----------------|-------|----------|-------------------|-------|
| N 31 22 871 | | 89 x 31 | 22 | 0,260 |





AISI 316

Bitta «STRONG»

Fabbricata in acciaio inox Aisi 316 lucidato a specchio.

Cleat «STRONG»

Made of Aisi 316 mirror polished stainless steel.

| Articolo - Item | €/pc. | A mm. | B mm. | C mm. | D mm. | E mm. | Prigionieri Ø mm. | Prigionieri (optional) | kg. |
|-----------------|-------|-------|-------|-------|-------|-------|-------------------|------------------------|------|
| N 30 20 006 | | 250 | 50 | 106,5 | 90 | 40,5 | 12 | N3012100 | 1,05 |



SUGGESTED ITEMS



AISI 316

Bitta «ELEGANCE»

Fabbricata in acciaio inox Aisi 316 lucidato a specchio. Fissaggio con 2 prigionieri.

Cleat «ELEGANCE»

Made of Aisi 316 mirror polished stainless steel. 2-stud mounting.

| Articolo - Item | €/pc. | A mm. | B mm. | C mm. | D mm. | Larg. mm. | Prigionieri Ø mm. | Prigionieri (optional) | kg. |
|------------------------|-------|-------|-------|-------|-------|-----------|-------------------|------------------------|------|
| N 30 12 205 | | 205 | 55 | 120 | 69 | 35 | 10 | N3010100 | 0,35 |
| N 30 15 265 | | 265 | 70 | 150 | 83 | 40 | 10 | N3010100 | 0,60 |
| N 30 20 310 NEW | | 310 | 80 | 200 | 83 | 45 | 10 | N3010100 | 0,85 |



SUGGESTED ITEMS

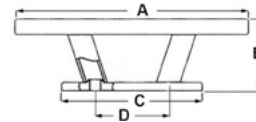

AISI 316

Bitta a fungo divaricato

Fabbricata in acciaio inox Aisi 316 lucidato a specchio. Fissaggio con 2 prigionieri.

Mushroom cleat

Made of Aisi 316 mirror polished stainless steel. 2-stud mounting.

| Articolo - Item | €/pc. | Base mm. | Larg. mm. | H mm. | Length mm. | Interasse mm. | Prigionieri Ø mm. | Prigionieri (optional) | kg. |
|-----------------|-------|----------|-----------|-------|------------|---------------|-------------------|------------------------|------|
| N 30 05 160 | | 160 | 55 | 60 | 160 | 71,8 | 8 | N3008090 | 0,73 |



SUGGESTED ITEMS



AISI 316

Bitta «HOLLOW CLEAT»

Fabbricata in acciaio inox Aisi 316.

Cleat «HOLLOW CLEAT»

Made of Aisi 316 stainless steel.

| Articolo - Item | €/pc. | Length mm. | Interasse - Holes mm. Long. | Trasv. mm. | Sottobase (optional) | kg. |
|-----------------|-------|------------|-----------------------------|------------|----------------------|---------------|
| N 30 00 150 | | 50 | 150 | 57,4 | 27,2 | N3045150 0,15 |
| N 30 00 200 | | 50 | 200 | 71,2 | 33,3 | N3045200 0,30 |
| N 30 00 250 | | 4 | 250 | 93,2 | 44,6 | 0,44 |



SUGGESTED ITEMS



Basetta «HOLLOW CLEAT»

In plastica bianca.

Base «HOLLOW CLEAT»

Made of white plastic.

| Articolo - Item | €/pair | Consigliati per bittre - Suggested for cleats | kg. |
|-----------------|--------|---|------|
| N 30 45 150 | 1 pair | N3000150 | 0,10 |
| N 30 45 200 | 1 pair | N3000200 | 0,10 |



AISI 316

Kit prigionieri per bittre in acciaio inox

Completi di (2 prigionieri, 2 dadi, 2 rondelle).

Stainless steel screws for cleat

Kit with 2 studs, 2 nuts, 2 washers.

| Articolo - Item | €/Kit | Consigliati per bittre - Suggested for cleats | mm. | kg. |
|-----------------|-------|---|----------|------|
| N 30 06 080 | | N3013150 | Ø 6x80 | 0,04 |
| N 30 08 090 | | N3013200-N3059200-N3014160-N3014200-N3005160 | Ø 8x90 | 0,07 |
| N 30 10 100 | | N3012205-N3015265-N3013250-N3075250-N3010250 | Ø 10x100 | 0,13 |
| N 30 12 100 | | N3020006-N3112300 | Ø 12x100 | 0,15 |



AISI 316

**Bitta «Duna Light»
(alleggerita)**

Realizzata in acciaio inox Aisi 316 lucidato a specchio.
Fissaggio tramite prigionieri.

Mooring cleat «Duna Light»

Manufactured in mirror polished Aisi 316 stainless steel.
Fixing by screws.

| Articolo - Item | €/pc. | Length mm. | Interasse Holes mm. | Prigionieri Ø mm. | Base (optional) | Prigionieri (optional) |
|-----------------|-------|------------|---------------------|-------------------|-----------------|------------------------|
| N 30 13 150 | | 150 | 45 | 6 | | N3006080 |
| N 30 13 200 | | 200 | 60 | 8 | N3032200 | N3008090 |
| N 30 13 250 | | 250 | 76 | 10 | N3032250 | N3010100 |



SUGGESTED ITEMS



AISI 316

Bitta «Duna»

Realizzata in acciaio inox Aisi 316 lucidato a specchio.
Fissaggio tramite prigionieri.

Mooring cleat «Duna»

Manufactured in mirror polished Aisi 316 stainless steel.
Fixing by screws.

| Articolo - Item | €/pc. | Length mm. | Interasse Holes mm. | Prigionieri Ø mm. | Base (optional) | Prigionieri (optional) |
|-----------------|-------|------------|---------------------|-------------------|-----------------|------------------------|
| N 30 59 200 | | 200 | 60 | 8 | N3032200 | N3008090 |
| N 30 75 250 | | 250 | 76 | 10 | N3032250 | N3010100 |



SUGGESTED ITEMS



AISI 316

Bitta «Duna» completa di prigionieri e basetta

Realizzata in acciaio inox Aisi 316 lucidato a specchio. Fissaggio tramite prigionieri.

Mooring cleat «Duna»

Manufactured in mirror polished Aisi 316 stainless steel. Fixing by screws.

| Articolo - Item | €/Kit. | Length mm. | Interasse Holes mm. | Prigionieri Ø mm. | Base (included) | Prigionieri (included) |
|-----------------|--------|------------|---------------------|-------------------|-----------------|------------------------|
| N 30 59 200C | | 200 | 60 | 8 | N3032200 | N3008090 |
| N 30 75 250C | | 250 | 76 | 10 | N3032250 | N3010100 |

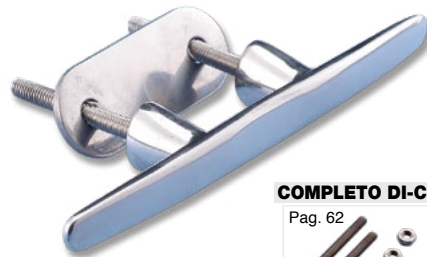

COMPLETO DI-COMLETE WITH



AISI 316

Basetta per bittle «Duna» di rinforzo/finitura

Reinforcement/finishing base for «Duna» cleats

| Articolo - Item | €/pc. | Length mm. | Consigliati per bittle - Suggested for cleats |
|-----------------|-------|----------------------|---|
| N 30 32 200 | | L.90X W.50 X Int.60 | N3059200 |
| N 30 32 250 | | L.110X W.50 X Int.76 | N3075250 |



AISI 316

Bitta «SILVER GATE»

Fabbricata in acciaio inox Aisi 316 lucidato a specchio.
Fissaggio tramite prigionieri.

Cleat «SILVER GATE»

Made of Aisi 316 mirror polished stainless steel.
Fixing by screws.

| Articolo - Item | €/pc. | A mm. | B mm. | C mm. | D mm. | E mm. | Prigionieri (suggested) ca | Basette plasti- (suggested) ca |
|-----------------|-------|-------|-------|-------|-------|-------|----------------------------|--------------------------------|
| N 30 14 160 | | 158 | 35 | 74 | 53 | 49 | 8 | N3014160 |
| N 30 14 200 | | 205 | 44 | 94 | 64 | 62 | 10 | N3014200 |
| N 30 14 250 | | 255 | 54 | 118 | 80 | 76 | 10 | N3014250 |



SUGGESTED ITEMS

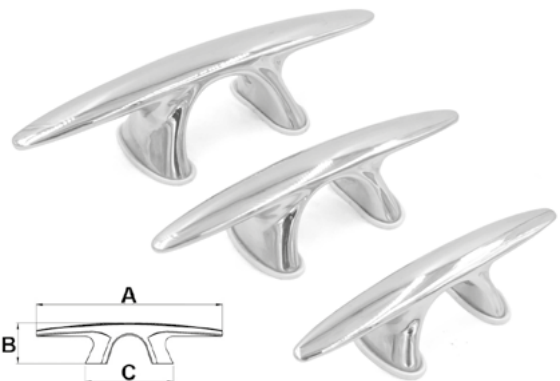
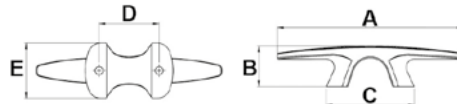
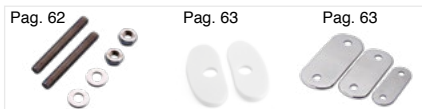

Basetta in plastica bianca per guarnizione bittle «SILVER GATE»

White plastic base to be fitted as washer under «SILVER GATE» cleats

| Articolo - Item | €/pair | Consigliati per bittle - Suggested for cleats |
|-----------------|--------|---|
| N 30 14 016 | 1 pair | N3014160 |
| N 30 14 020 | 1 pair | N3014200 |
| N 30 14 025 | 1 pair | N3010250 |



Contropiastra di rinforzo per guarnizione bittle «SILVER GATE»

Reinforcement counterplate for «SILVER GATE» cleats

| Articolo - Item | €/pc | Length mm. | Consigliati per bittle - Suggested for cleats |
|-----------------|------|----------------------|---|
| N 30 32 016 | | L.80X W.45 X Int.53 | N3014160 |
| N 30 32 020 | | L.95X W.55 X Int.64 | N3014200 |
| N 30 32 025 | | L.120X W.70 X Int.80 | N3010250 |





STAINLESS STEEL

Bitta in acciaio inox «ENDURANCE»

Lucidata a specchio. Completa di vite per il fissaggio.

Stainless steel cleat «ENDURANCE»

Mirror polished. Supplied with fixing screws.

| Articolo - Item | €/pc. | Length mm. | Interasse Holes mm. | kg. |
|-----------------|-------|------------|---------------------|-------|
| N 30 08 042 | | 200 | 88 | 0,290 |
| N 30 10 042 | | 250 | 106 | 0,530 |

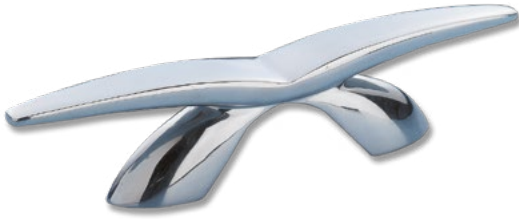

AISI 316

Bitta in acciaio inox Aisi 316 «EAGLE»

Realizzata in acciaio inox Aisi 316.

Aisi 316 stainless steel cleat «EAGLE»

Made of Aisi 316 stainless steel.

| Articolo - Item | €/pc. | Length mm. | Filetto - Thread Ø | H mm. | kg. |
|-----------------|-------|------------|--------------------|-------|-------|
| N 30 08 215 | | 220 | M8 | 50 | 0,720 |



AISI 316

Bitta con passacavo

Realizzata in acciaio inox Aisi 316.

Mooring cleat with eye

Made of Aisi 316 stainless steel.

| Articolo - Item | €/pc. | Length mm. | Fissaggio-Fixing Ø mm. | H mm. | kg. |
|-----------------|-------|------------|------------------------|-------|-------|
| N 30 50 356 | | 175 | 62 | 68 | 0,380 |



BITTE IN OTTONE | BRASS CLEATS



Bitta «HOLLOW CLEAT»

Fabbricata in ottone cromato.

«HOLLOW CLEAT» mooring cleat

Made of chromed brass.

| Articolo - Item | €/pc. | Length mm. | Pollici - Inches | kg. |
|-----------------|-------|------------|------------------|-------|
| N 31 00 150 | | 150 | 6 | 0,100 |
| N 31 00 200 | | 200 | 8 | 0,150 |



Bitta per ormeggio con traversino in legno

Fabbricata in ottone cromato con passante orizzontale in legno di mogano.

Cross bollards

Made of chromium plated brass. Provided with a ledge of mahogany wood.

| Articolo - Item | €/pc. | Length barra-bar mm. | mm. | kg. |
|-----------------|-------|----------------------|-----------------|-------|
| N 31 00 215 | | 215 | 138 x 32 x 40 H | 0,250 |



GRILLI | SHACKLES

AISI 316

Grillo in acciaio inox Aisi 316 Aisi 316 stainless steel bow shackle

| Articolo - Item | €/pc. | €/box | A mm. | B mm. | C mm. | D mm. | Ø mm. | kg. | kg. | kg. |
|-----------------|-------|-------|-------|-------|-------|-------|-------|------|-----|-------|
| M 12 04 095 | | | 9 | 7 | 27 | 18 | 4 | 735 | 10 | 0,080 |
| M 12 05 018 | | | 11 | 9 | 30 | 19 | 5 | 1050 | 10 | 0,130 |
| M 12 06 022 | | | 13 | 11 | 38 | 25 | 6 | 1750 | 10 | 0,250 |
| M 12 08 030 | | | 16 | 13 | 50 | 35 | 8 | 3300 | 10 | 0,580 |
| M 12 10 080 | | | 21 | 17 | 63 | 38 | 10 | 4800 | 5 | 0,575 |
| M 12 12 100 | | | 24 | 19 | 79 | 48 | 12 | 5200 | 1 | 0,200 |
| M 12 16 140 | | | 34 | 25 | 98 | 65 | 16 | 6800 | 1 | 0,500 |

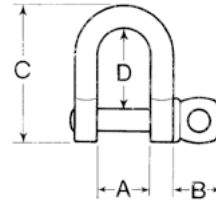

AISI 316

Grillo a cetra in acciaio inox Aisi 316 Aisi 316 stainless steel D bow shackle

| Articolo - Item | €/pc. | €/box | A mm. | B mm. | C mm. | D mm. | Ø mm. | kg. | kg. | kg. |
|------------------------|-------|-------|-------|-------|-------|-------|-------|------|-----|-------|
| M 21 05 020 NEW | | | 9 | 10 | 32 | 17 | 5 | 1000 | 10 | 0,200 |
| M 21 06 031 | | | 11 | 10 | 42 | 18 | 6 | 1750 | 10 | 0,300 |
| M 21 08 040 | | | 17 | 10 | 49 | 24 | 8 | 3300 | 10 | 0,630 |
| M 21 10 050 | | | 19 | 15 | 65 | 30 | 10 | 4800 | 5 | 0,600 |
| M 21 12 060 | | | 27 | 18 | 73 | 38 | 12 | 5200 | 1 | 0,207 |
| M 21 16 080 | | | 34 | 20 | 107 | 46 | 16 | 6800 | 1 | 0,520 |

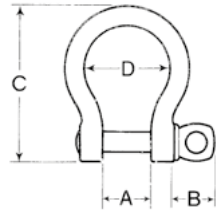

AISI 316

Grillo con perno imperdibile in acciaio inox Aisi 316 Aisi 316 stainless steel shackle with captive pin

| Articolo - Item | €/pc. | €/box | A mm. | B mm. | C mm. | D mm. | Ø mm. | kg. | kg. | kg. |
|-----------------|-------|-------|-------|-------|-------|-------|-------|------|-----|-------|
| M 12 06 013 | | | 12 | 11 | 38 | 24 | 6 | 1600 | 10 | 0,250 |
| M 12 08 016 | | | 16 | 13 | 46 | 26 | 8 | 3200 | 10 | 0,580 |

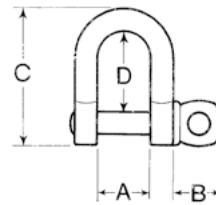

AISI 316

Grillo modello lungo in acciaio inox Aisi 316 Aisi 316 stainless steel long bow shackle

| Articolo - Item | €/pc. | €/box | A mm. | B mm. | C mm. | D mm. | Ø mm. | kg. | kg. | kg. |
|------------------------|-------|-------|-------|-------|-------|-------|-------|------|-----|-------|
| M 00 05 050 | | | 11 | 9 | 48 | 40 | 5 | 1050 | 10 | 0,200 |
| M 00 06 054 NEW | | | 12 | 10 | 54 | 48 | 6 | 1500 | 10 | 0,350 |
| M 00 08 072 NEW | | | 16 | 12 | 72 | 64 | 8 | 3000 | 10 | 0,600 |
| M 00 10 080 NEW | | | 20 | 15 | 90 | 80 | 10 | 5000 | 1 | 0,650 |

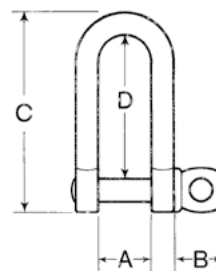

AISI 316

Grillo ritorto in acciaio inox Aisi 316 Aisi 316 stainless steel twisted shackle

| Articolo - Item | €/pc. | €/box | A mm. | B mm. | C mm. | D mm. | Ø mm. | kg. | kg. | kg. |
|-----------------|-------|-------|-------|-------|-------|-------|-------|------|-----|-------|
| M 09 05 020 | | | 11 | 9 | 39 | 27 | 5 | 1200 | 10 | 0,180 |

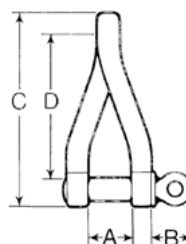

**AISI 316**

Grillo in acciaio inox Aisi 316
con vite a scomparsa

Aisi 316 stainless steel shackle
with screw pin

| Articolo - Item | €/pc. | €/box | Length mm. | H mm. | Ø mm. | kg. | kg. | kg. |
|-----------------|-------|-------|------------|-------|-------|------|-----|-------|
| M 12 06 014 | | | 11 | 20 | 6 | 2800 | 10 | 0,250 |
| M 12 08 017 | | | 16 | 31 | 8 | 3500 | 10 | 0,580 |
| M 12 10 022 | | | 21 | 35 | 10 | 5400 | 5 | 0,575 |

**AISI 316**

Grillo extra largo in acciaio inox
Aisi 316

Aisi 316 stainless steel extra large
shackle

| Articolo - Item | €/pc. | Length mm. | H mm. | Ø mm. | kg. | kg. | kg. |
|------------------------|-------|------------|-------|-------|------|-----|-------|
| M 12 10 040 | | 40 | 55 | 10 | 1600 | 1 | 0,143 |
| M 12 12 048 NEW | | 48 | 75 | 12 | 2500 | 1 | 0,200 |

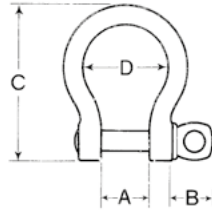

Grillo a cetra in acciaio zincato

Galvanized steel D bow shackle

| Articolo - Item | €/pc. | €/box | A mm. | B mm. | C mm. | D mm. | Ø mm. | kg. | kg. | kg. |
|------------------------|-------|-------|-------|-------|-------|-------|-------|------|-----|-------|
| M 13 06 011 NEW | | | 11 | 10 | 42 | 18 | 6 | 700 | 10 | 0,500 |
| M 13 08 014 | | | 17 | 10 | 49 | 24 | 8 | 1000 | 10 | 0,630 |
| M 13 10 016 | | | 19 | 15 | 65 | 30 | 10 | 1600 | 10 | 0,600 |
| M 13 12 023 | | | 27 | 18 | 73 | 38 | 12 | 2500 | 10 | 0,207 |
| M 13 14 025 | | | 28 | 18 | 92 | 45 | 14 | 3000 | 10 | 2,800 |
| M 13 16 032 | | | 34 | 20 | 107 | 46 | 16 | 4000 | 5 | 0,520 |
| M 13 18 032 | | | 35 | 20 | 113 | 54 | 18 | 5000 | 5 | 0,700 |
| M 13 20 038 | | | 35 | 20 | 128 | 57 | 20 | 5500 | 5 | 1,000 |

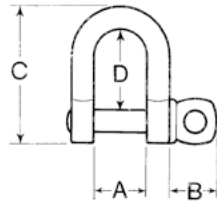

Grillo in acciaio zincato

Galvanized steel bow shackle

| Articolo - Item | €/pc. | €/box | A mm. | B mm. | C mm. | D mm. | Ø mm. | kg. | kg. | kg. |
|-----------------|-------|-------|-------|-------|-------|-------|-------|------|-----|-------|
| M 13 06 025 | | | 13 | 11 | 38 | 25 | 6 | 500 | 10 | 0,250 |
| M 13 08 045 | | | 16 | 13 | 50 | 35 | 8 | 1000 | 10 | 0,580 |
| M 13 10 060 | | | 21 | 17 | 63 | 38 | 10 | 1600 | 10 | 0,575 |
| M 13 12 070 | | | 24 | 19 | 79 | 48 | 12 | 2500 | 10 | 0,200 |
| M 13 14 056 | | | 30 | 22 | 90 | 55 | 14 | 3000 | 10 | 0,400 |
| M 13 16 080 | | | 34 | 25 | 98 | 65 | 16 | 4000 | 5 | 0,500 |

GAMBETTI E MEZZI ANELLI | SHACKLES & BUCKLES

**AISI 316**

Mezzi anelli in acciaio inox
Aisi 316

Aisi 316 stainless steel buckles
for belt

| Articolo - Item | €/pc. | mm. | kg. |
|-----------------|-------|---------|-------|
| M 35 00 113 | | 45 x 45 | 0,050 |



Chiave gambetti in acciaio zincato

Galvanized steel shackle key

| Articolo - Item | €/pc. | €/box 6 pc | kg. | kg. |
|-----------------|-------|------------|-----|-------|
| M 18 00 020 | | | 6 | 0,138 |

AISI 316

Cavallotto a «U» Aisi 316 con due piastre

In acciaio inox Aisi 316 ricavato dal pieno, con due piastrelle e due dadi.

Aisi 316 U-bolts

Complete with double plate and nuts.

| Articolo - Item | €/pc. | €/box | Ø filetto mm. | Ø tondo mm. | A mm. | B mm. | C mm. | D mm. | E mm. | |
|-----------------|-------|-------|---------------|-------------|-------|-------|-------|-------|-------|---|
| N 34 08 090 | | | M6 | 8 | 41 | 40 | 31 | 90 | 36 | 6 |
| N 34 10 101 | | | M8 | 10 | 30 | 38 | 29 | 80 | 35 | 6 |
| N 34 10 120 | | | M8 | 10 | 32 | 57 | 30 | 102 | 36 | 6 |
| N 34 12 130 | | | M10 | 12 | 38 | 89 | 40 | 140 | 50 | 1 |
| N 34 14 150 | | | M12 | 14 | 54 | 82 | 48 | 155 | 58 | 1 |

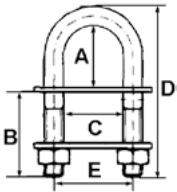

RICAVATO DAL PIENO

AISI 316

Cavallotto a «U» Aisi 316 con guarnizione in gomma

In acciaio inox Aisi 316 lucidato a specchio, con due piastrelle e due dadi.

Aisi 316 U-bolts with rubber gasket

Complete with double plate, nuts and gasket.

| Articolo - Item | €/pc. | Ø filetto mm. | Ø tondo mm. | A mm. | B mm. | C mm. | D mm. | E mm. | |
|-----------------|-------|---------------|-------------|-------|-------|-------|-------|-------|---|
| N 34 10 065 | | 8 | 9 | 30 | 62 | 30 | 104 | 37 | 1 |
| N 34 12 075 | | 10 | 12 | 50 | 74 | 39 | 142 | 48 | 1 |

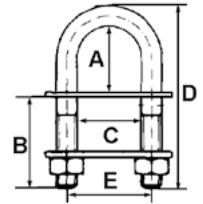

AISI 316

Golfare Aisi 316

Completo di dado e rondella.

Aisi 316 eyebolt

Complete with washer and nut.

| Articolo - Item | €/pc. | €/box | D1 | L mm. | D mm. | W mm. | |
|-----------------|-------|-------|----|-------|-------|-------|----|
| M 20 12 042 | | | 6 | 30 | M6 | 13 | 10 |
| M 20 13 087 | | | 6 | 60 | M6 | 13 | 5 |
| M 20 14 055 | | | 8 | 35 | M8 | 15 | 6 |

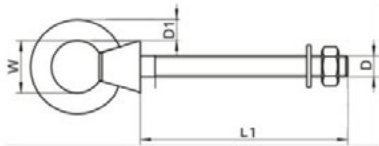

AISI 316

Golfare Aisi 316

Completo di dado e rondella.

Aisi 316 long eyebolt

Complete with washer and nut.

| Articolo - Item | €/pc. | €/box | D1 | L mm. | D mm. | W mm. | |
|-----------------|-------|-------|-----|-------|-------|-------|---|
| N 34 08 082 | | | M8 | 80 | 6 | 20 | 6 |
| N 34 08 102 | | | M8 | 100 | 6 | 20 | 6 |
| N 34 08 122 | | | M10 | 100 | 8 | 25 | 6 |
| N 34 12 120 | | | M12 | 120 | 10 | 30 | 6 |

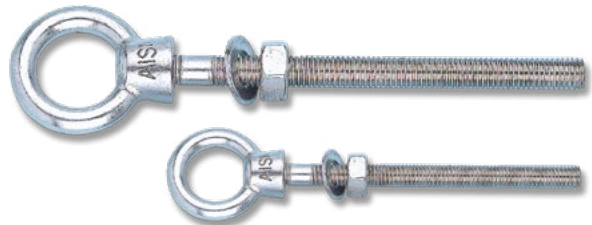
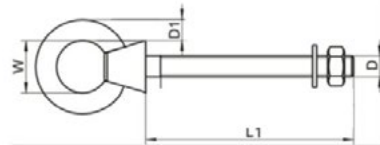

AISI 316

Golfare femmina

Ad occhio circolare in acciaio inox Aisi 316 con foro filettato.

Aisi 316 female eyebolt

Round eye and threaded hole.

| Articolo - Item | €/pc. | €/box | D | B mm. | D2 mm. | C mm. | H mm. | |
|-----------------|-------|-------|-----|-------|--------|-------|-------|----|
| M 20 06 582 | | | M 6 | 16 | 15 | 6 | 28 | 10 |
| M 20 08 582 | | | M 8 | 20 | 20 | 8 | 35 | 10 |
| M 20 10 582 | | | M10 | 25 | 25 | 10 | 44 | 10 |

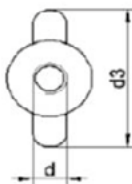
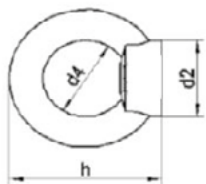

AISI 316

Moschettone

In acciaio inox Aisi 316, apertura a molla.

Snap shackle

Made of Aisi 316 stainless steel, with spring.

| Articolo - Item | €/pc. | €/box | L mm. | W mm. | D mm. | E mm. | kg. | pcs. | kg. |
|-----------------|-------|-------|-------|-------|-------|-------|-----|------|-------|
| M 06 32 050 | | | 50 | 24 | 6,5 | 10 | 400 | 6 | 0,250 |
| M 06 32 075 | | | 70 | 31 | 10 | 13 | 800 | 6 | 0,350 |

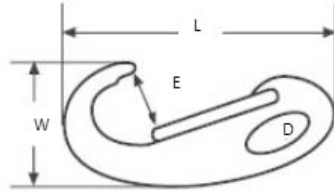

AISI 316

Moschettone con apertura a vite

In acciaio inox Aisi 316, straordinariamente robusto.

Snap screw shackle

Made of Aisi 316 stainless steel, with screw.

| Articolo - Item | €/pc. | €/box | D mm. | L mm. | B mm. | E mm. | pcs. | kg. |
|-----------------|-------|-------|-------|-------|-------|-------|------|-------|
| M 03 08 054 | | | 8 | 75 | 18 | 9,5 | 10 | 0,600 |

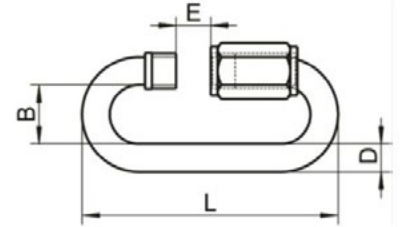
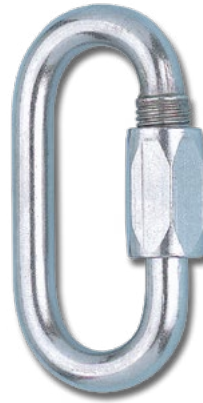

AISI 316

Moschettone per Spinnaker e drizze

In acciaio inox Aisi 316.

Snap shackle for spinnaker, halyards & general purposes

Made of Aisi 316 stainless steel.

| Articolo - Item | €/pc. | €/box | A mm. | B mm. | L mm. | kg. | pcs. | kg. |
|-----------------|-------|-------|-------|-------|-------|------|------|-------|
| M 06 07 050 | | | 12 | 9 | 54 | 700 | 6 | 0,250 |
| M 06 07 070 | | | 16 | 12 | 70 | 1100 | 1 | 0,080 |

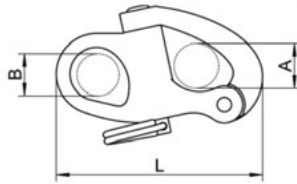

AISI 316

Moschettone girevole per Spinnaker

In acciaio inox Aisi 316, lucidato a specchio. Occhio girevole.

Snap shackle for spinnaker, halyards & general purposes

Made of Aisi 316 stainless steel with swivelling eye.

| Articolo - Item | €/pc. | A mm. | B mm. | L mm. | kg. | pcs. | kg. |
|-----------------|-------|-------|-------|-------|------|------|-------|
| M 06 07 085 | | 12 | 12 | 70 | 1500 | 1 | 0,100 |
| M 06 07 095 | | 16 | 16 | 87 | 2500 | 1 | 0,140 |
| M 06 07 135 | | 22 | 22 | 128 | 5500 | 1 | 0,200 |

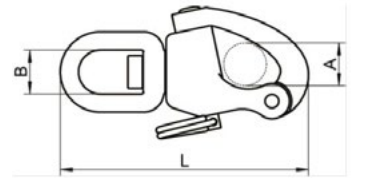

AISI 316

Moschettone con doppia sicurezza

Fabbricato in acciaio inox Aisi 316. Da utilizzare per cinture di sicurezza.

Snap-hook with double safety lock

Aisi 316 stainless steel. Specially designed for safety belts.

| Articolo - Item | €/pc. | Length mm. | Apertura Opening | kg. | pcs. | kg. |
|-----------------|-------|------------|------------------|------|------|-------|
| M 07 10 110 | | 106 | Ø 16 mm. | 2000 | 1 | 0,200 |



Moschettone con anello girevole

Fabbricato in ottone pressofuso cromato.

Swivel eye snap-hook

Manufactured in chromed diecast brass.

| Articolo - Item | €/pc. | €/box | Length mm. | pcs. | kg. |
|-----------------|-------|-------|------------|------|-------|
| M 02 00 062 | | | 82 | 6 | 0,360 |



AISI 316

Moschettone Aisi 316

In acciaio inox Aisi 316, modello a pera con chiusura a coda di rondine.

Aisi 316 snap shackle

Made of Aisi 316 stainless steel.

| Articolo - Item | €/pc. | €/box | D mm. | L mm. | A mm. | E mm. | pcs. |
|-----------------|-------|-------|-------|-------|-------|-------|------|
| M 05 04 040 | | | 4 | 40 | 6,5 | 6 | 10 |
| M 05 05 050 | | | 5 | 50 | 8 | 7 | 10 |
| M 05 06 060 | | | 6 | 60 | 9 | 8 | 10 |
| M 05 07 070 | | | 7 | 70 | 10,5 | 8 | 10 |
| M 05 08 080 | | | 8 | 80 | 12 | 9 | 10 |
| M 05 10 100 | | | 10 | 100 | 15 | 12 | 5 |
| M 05 12 120 | | | 11 | 120 | 18 | 16 | 1 |
| M 05 14 140 | | | 14 | 180 | 22 | 21 | 1 |

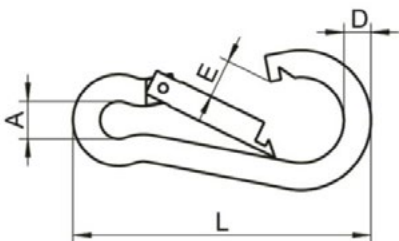

AISI 316

Moschettone fermo a vite

In acciaio inox Aisi 316, chiusura a coda di rondine, fermo a vite. Apertura interna.

Aisi 316 snap shackle

Made of Aisi 316 stainless steel. Screw locking system.

| Articolo - Item | €/pc. | D mm. | L mm. | A mm. | E mm. | pcs. |
|-----------------|-------|-------|-------|-------|-------|------|
| M 06 10 100 | | 10 | 100 | 15 | 11 | 1 |

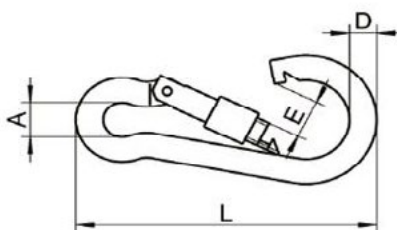

AISI 316

Moschettone apertura trasversale

In acciaio inox Aisi 316, con ampia apertura trasversale che offre un maggiore passaggio.

Snap shackle asymmetric opening

Made of Aisi 316 stainless steel.

| Articolo - Item | €/pc. | D mm. | L mm. | A mm. | E mm. | pcs. |
|-----------------|-------|-------|-------|-------|-------|------|
| M 05 00 080 | | 8 | 80 | 12 | 19 | 1 |
| M 05 00 100 | | 10 | 100 | 15 | 22 | 1 |

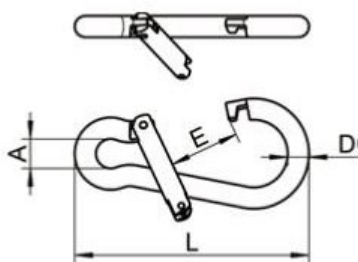

Moschettone zincato

In acciaio zincato, modello a pera.

Galvanised steel snap shackle

Made of galvanised steel.

| Articolo - Item | €/pc. | €/box | D mm. | L mm. | A mm. | E mm. | pcs. |
|-----------------|-------|-------|-------|-------|-------|-------|------|
| M 32 05 050 | | | 5 | 50 | 8 | 6,5 | 10 |
| M 32 06 060 | | | 6 | 60 | 9 | 7,5 | 10 |
| M 32 07 070 | | | 7 | 70 | 10 | 8 | 10 |
| M 32 08 080 | | | 8 | 80 | 12 | 9 | 10 |
| M 32 10 100 | | | 10 | 100 | 15 | 12 | 10 |

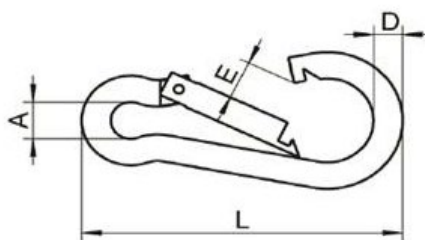

AISI 316

Moschettone con occhiello

In acciaio inox Aisi 316, modello a pera con anello nell'occhiello con chiusura dritta.

Eye snap shackle

Made of Aisi 316 stainless steel.

| Articolo - Item | €/pc. | €/box | D mm. | L mm. | A mm. | E mm. | pcs. |
|-----------------|-------|-------|-------|-------|-------|-------|------|
| M 04 05 050 | | | 5 | 50 | 6,5 | 7 | 10 |
| M 04 06 060 | | | 6 | 60 | 7,5 | 8 | 10 |
| M 04 07 070 | | | 7 | 70 | 9 | 8 | 10 |
| M 04 08 080 | | | 8 | 80 | 10 | 9 | 10 |
| M 04 10 100 | | | 10 | 100 | 13 | 12 | 5 |

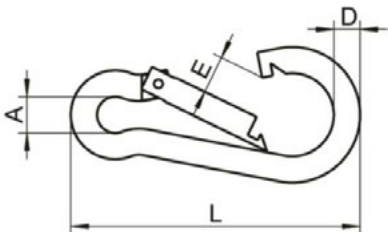

AISI 316

Moschettone in acciaio inox a grande apertura

In acciaio inox Aisi 316 lucidato a specchio, risolve il problema dei moschettoni legato alla scarsa apertura degli stessi.

Aisi 316 wide opening snap shackle

Made of Aisi 316 mirror polished stainless steel.

| Articolo - Item | €/pc. | D mm. | L mm. | kg. | Passaggio mm. | pcs. |
|-----------------|-------|-------|-------|------|---------------|------|
| M 06 10 101 | | 10 | 100 | 2200 | 19 | 1 |

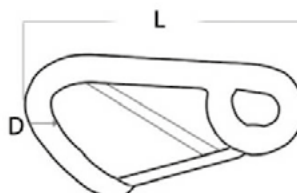

AISI 316

Base tonda 60°

Tonda inclinata 60° in acciaio inox Aisi 316 lucidato a specchio.

Round base 60°

Made of Aisi 316 mirror polished stainless steel.

| Articolo - Item | €/pc. | Pipe Ø mm. | Base Ø mm. | H mm. | kg. |
|-----------------|-------|------------|------------|-------|-------|
| N 42 22 043 | | 22 | 66 | 43 | 0,210 |
| N 42 25 043 | | 25 | 70 | 43 | 0,230 |



AISI 316

Base tonda 90°

Tonda dritta 90° in acciaio inox Aisi 316 lucidato a specchio.

Round base 90°

Made of Aisi 316 mirror polished stainless steel.

| Articolo - Item | €/pc. | Pipe Ø mm. | Base Ø mm. | H mm. | kg. |
|-----------------|-------|------------|------------|-------|-------|
| N 42 22 061 | | 22 | 66 | 43 | 0,210 |
| N 42 25 061 | | 25 | 70 | 43 | 0,240 |



AISI 316

Base rettangolare 60°

Rettangolare inclinata 60° in acciaio inox Aisi 316 lucidato a specchio.

Rectangular base 60°

Made of Aisi 316 mirror polished stainless steel.

| Articolo - Item | €/pc. | Pipe Ø mm. | Base mm. | H mm. | kg. |
|-----------------|-------|------------|----------|-------|-------|
| N 42 22 042 | | 22 | 76x44 | 43 | 0,190 |
| N 42 25 042 | | 25 | 81x48 | 43 | 0,230 |

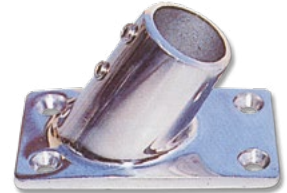

AISI 316

Base rettangolare 90°

Rettangolare dritta 90° in acciaio inox Aisi 316 lucidato a specchio.

Rectangular base 90°

Made of Aisi 316 mirror polished stainless steel.

| Articolo - Item | €/pc. | Pipe Ø mm. | Base mm. | H mm. | kg. |
|-----------------|-------|------------|----------|-------|-------|
| N 42 22 056 | | 22 | 76x44 | 43 | 0,200 |
| N 42 25 056 | | 25 | 81x48 | 43 | 0,240 |

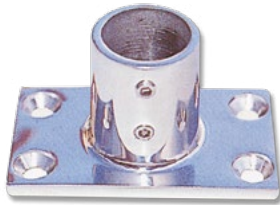

AISI 316

Terminali

Per corrimano, in acciaio inox Aisi 316.

End fittings

Made of Aisi 316 stainless steel. Suitable for handrail.

| Articolo - Item | €/pc. | Pipe Ø mm. | Length mm. | H mm. | kg. |
|-----------------|-------|------------|------------|-------|-------|
| N 42 22 602 | | 22 | 171 | 38 | 0,160 |



AISI 316

T dritto 90° microfuso

In acciaio inox Aisi 316 lucidato a specchio.

T 90° pulpit joint

Made of Aisi 316 mirror polished stainless steel.

| Articolo - Item | €/pc. | Pipe Ø mm. | L mm. | H mm. | kg. |
|-----------------|-------|------------|-------|-------|-------|
| N 42 22 054 | | 22 | 50 | 50 | 0,160 |
| N 42 25 054 | | 25 | 55 | 55 | 0,190 |

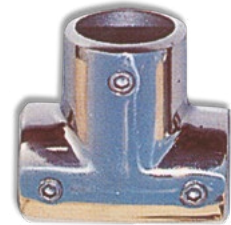
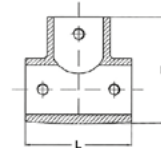

AISI 316

Angolare 90° microfuso

In acciaio inox Aisi 316 lucidato a specchio.

90° pulpit joint

Made of Aisi 316 mirror polished stainless steel.

| Articolo - Item | €/pc. | Pipe Ø mm. | B mm. | H mm. | kg. |
|-----------------|-------|------------|-------|-------|-------|
| N 42 22 076 | | 22 | 49 | 23 | 0,120 |
| N 42 25 076 | | 25 | 51 | 23 | 0,160 |

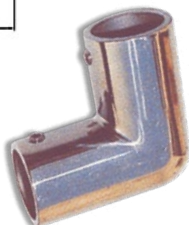
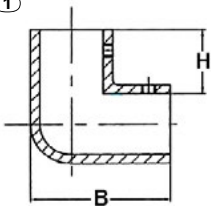

AISI 316

Angolare 90° a 4 vie microfuso

In acciaio inox Aisi 316 lucidato a specchio.

90° 4-way pulpit joint

Made of Aisi 316 mirror polished stainless steel.

| Articolo - Item | €/pc. | Pipe Ø mm. | B mm. | H mm. | kg. |
|-----------------|-------|------------|-------|-------|-------|
| N 42 22 652 | | 22 | 54,5 | 29 | 0,220 |
| N 42 25 652 | | 25 | 56 | 27 | 0,230 |

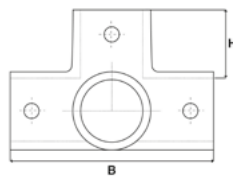

AISI 316

T inclinato 60° microfuso

In acciaio inox Aisi 316 lucidato a specchio.

T 60° pulpit joint

Made of Aisi 316 mirror polished stainless steel.

| Articolo - Item | €/pc. | Pipe Ø mm. | L mm. | H mm. | kg. |
|-----------------|-------|------------|-------|-------|-------|
| N 42 22 062 | | 22 | 50 | 57 | 0,170 |
| N 42 25 062 | | 25 | 55 | 65 | 0,180 |

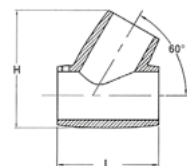

AISI 316

Angolo a «T»
inclinato a 60°
con attacco cavo
Aisi 316

Aisi 316 T 60° pul-
pit joint with cable
connection

| Articolo - Item | €/pc. | Ø mm. | kg. |
|-----------------|-------|-------|-------|
| N 42 22 522 | | 22 | 0,200 |



AISI 316

Angolo a 90°
con attacco cavo
Aisi 316

Aisi 316 T 90° pul-
pit joint with cable
connection

| Articolo - Item | €/pc. | Ø mm. | kg. |
|-----------------|-------|-------|-------|
| N 42 22 523 | | 22 | 0,200 |



AISI 316

Base per candelieri
in acciaio inox
Aisi 316

Aisi 316 stainless
steel stanchion
base

| Articolo - Item | €/pc. | Mod. | Ø mm. | kg. |
|-----------------|-------|--------------------|-------|-------|
| S 23 25 080 | | Perpendicolare 90° | 25 | 0,200 |



AISI 316

Base conica a 60° 60° conical base

| Articolo - Item | €/pc. | H mm. | Base Ø mm. | Ø int. mm. | Ø Filetto mm. |
|-----------------|-------|-------|------------|------------|---------------|
| N 42 30 070 | | 80 | 52 | 30 | 7 |



AISI 316

Base conica a 90° 90° conical base

| Articolo - Item | €/pc. | H mm. | Base Ø mm. | Ø int. mm. | Ø Filetto mm. |
|-----------------|-------|-------|------------|------------|---------------|
| N 42 30 062 | | 80 | 52 | 30 | 7 |



AISI 316

Base per candelieri
90°

Stanchion base
90°

In acciaio inox Aisi 316 priva
di fori

Aisi 316 stainless steel
without holes.

| Articolo - Item | €/pc. | Ø mm. | kg. |
|-----------------|-------|-------|-------|
| N 42 25 061 C | | 25 | 0,160 |



Supporto in ottone
cromato per corri-
mano e tientibene

Chromed brass
connector
for handrails

Fabbricato in ottone cromato.

Manufactured in chromed
brass.

| Articolo - Item | €/pc. | A mm. | B mm. | C mm. | Foro Hole | kg. |
|-----------------|-------|-------|-------|-------|-----------|-----|
| N 43 35 077 | | 25 | 65 | 35 | Passante | 1 |

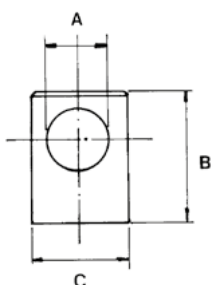

AISI 316

Supporto centrale
per corrimano

Central connector
for handrails

Fabbricato in acciaio inox
Aisi 316.

Manufactured in Aisi 316
stainless steel.

| Articolo - Item | €/pc. | Ø mm. | A mm. | B mm. | H mm. |
|-----------------|-------|-------|-------|-------|-------|
| N 42 22 049 | | 22 | 40 | 26 | 38 |
| N 42 25 041 | | 25 | 42 | 29 | 38 |

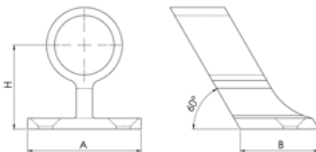

AISI 316

Supporto terminale
per corrimano

End fitting connector
for handrails

Fabbricato in acciaio inox
Aisi 316.

Manufactured in Aisi 316
stainless steel.

| Articolo - Item | €/pc. | Ø mm. | A mm. | B mm. | H mm. |
|-----------------|-------|-------|-------|-------|-------|
| N 42 22 048 | | 22 | 40 | 26 | 38 |
| N 42 25 044 | | 25 | 42 | 29 | 38 |

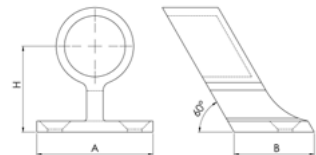

AISI 316

Base tonda 60° **60° round base**
In acciaio inox stampato. Made of stainless steel.

| Articolo - Item | €/pc. | O mm. | kg. |
|-----------------|-------|-------|-------|
| N 42 22 050 | | 22 | 0,060 |
| N 42 25 050 | | 25 | 0,070 |

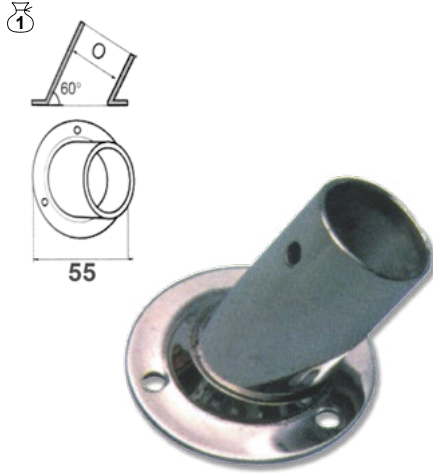

AISI 316

Base tonda 90° **90° round base**
In acciaio inox stampato. Made of stainless steel.

| Articolo - Item | €/pc. | O mm. | kg. |
|-----------------|-------|-------|-------|
| N 42 25 055 | | 25 | 0,070 |

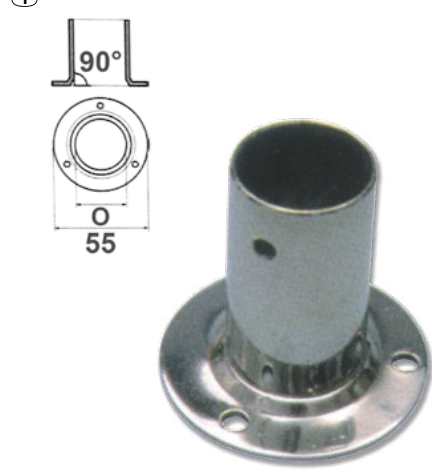

AISI 316

Base quadra 60° **60° rectangular base**
In acciaio inox stampato. Made of stainless steel.

| Articolo - Item | €/pc. | O mm. | kg. |
|-----------------|-------|-------|-------|
| N 42 25 058 | | 25 | 0,070 |

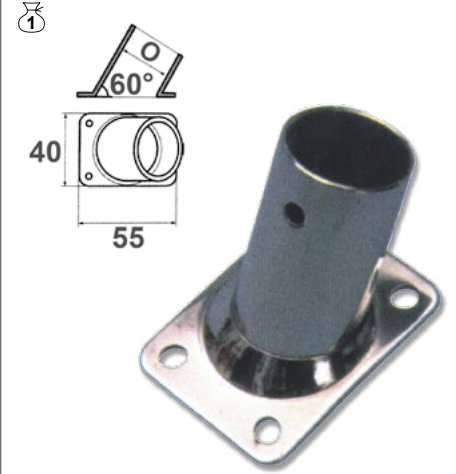

AISI 316

Giunto T 90° **T 90° pulpit joint**
In acciaio inox stampato. Made of stainless steel.

| Articolo - Item | €/pc. | O mm. | kg. |
|-----------------|-------|-------|-------|
| N 42 22 073 | | 22 | 0,060 |
| N 42 25 073 | | 25 | 0,070 |

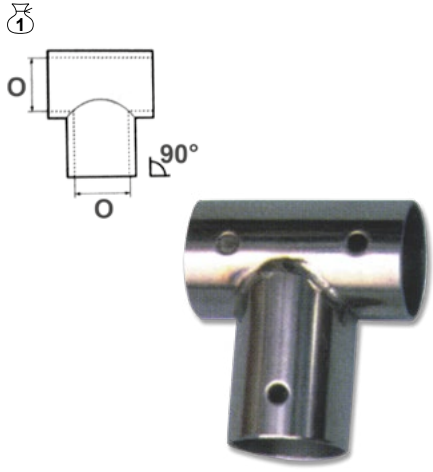

AISI 316

Base a saldare tonda 60° **60° round base**
In acciaio inox stampato. Made of stainless steel.

| Articolo - Item | €/pc. | O mm. | kg. |
|-----------------|-------|-------|-------|
| N 42 22 066 | | 22 | 0,040 |
| N 42 25 066 | | 25 | 0,040 |
| N 42 28 066 | | 28 | 0,040 |



AISI 316

Base a saldare tonda 90° **90° round base**
In acciaio inox stampato. Made of stainless steel.

| Articolo - Item | €/pc. | O mm. | kg. |
|-----------------|-------|-------|-------|
| N 42 22 096 | | 22 | 0,040 |

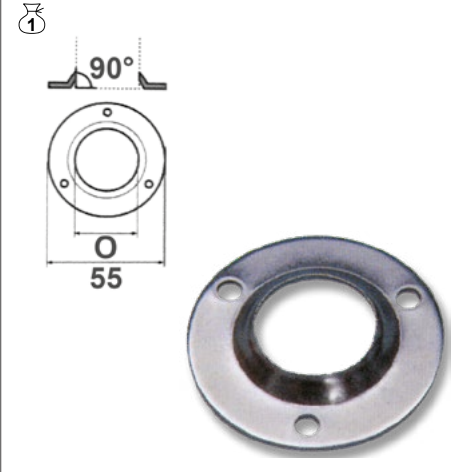

AISI 316

Base a saldare rettangolare 60° **60° rectangular base**
In acciaio inox stampato. Made of stainless steel.

| Articolo - Item | €/pc. | O mm. | kg. |
|-----------------|-------|-------|-------|
| N 42 25 063 | | 25 | 0,030 |

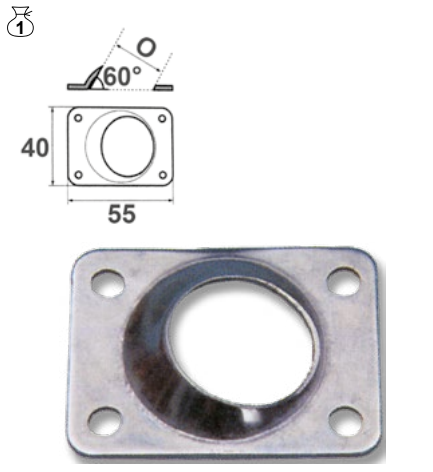

AISI 316

Base a saldare rettangolare 90° **90° rectangular base**
In acciaio inox stampato. Made of stainless steel.

| Articolo - Item | €/pc. | O mm. | kg. |
|-----------------|-------|-------|-------|
| N 42 28 093 | | 28 | 0,030 |

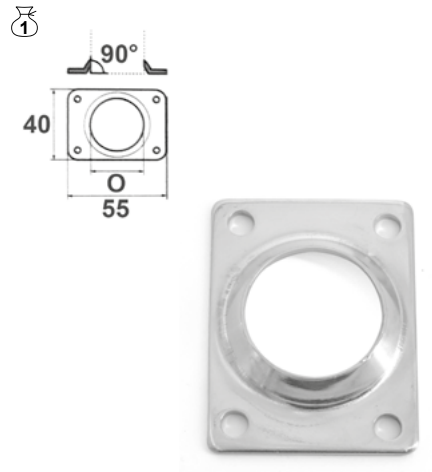

Guarnizione per basi pulpito **Plastic gasket for pulpit base**

In plastica. Made of resistant plastic.

| Articolo - Item | € Box da 12 pz. | Mod. | Ø mm. | kg. |
|-----------------|-----------------|------|-------|-------|
| N 42 62 000 | | ○ | 62 | 0,010 |
| N 42 50 064 | | □ | 64x56 | 0,010 |
| N 42 76 000 | | ○ | 76 | 0,010 |



AISI 316

Tubo in acciaio inox Aisi 316 lucidato a specchio **Mirror polished Aisi 316 stainless steel pipe**

| Barre da 3 mt. | | Bars of 3 mt. | |
|-----------------|------------|---------------|------------------------|
| Articolo - Item | €/pc.3 mt. | Ø mm. | Spessore Thickness mm. |
| O 32 22 003 | | 22 | 1,2 |
| O 32 25 310 | | 25 | 1,5 |
| O 32 30 015 | | 30 | 1,5 |



ALU

Tubo in alluminio anodizzato **Anodised alu pipe**

| Barre da 3 mt. | | Bars of 3 mt. | |
|-----------------|------------|---------------|------------------------|
| Articolo - Item | €/pc.3 mt. | Ø mm. | Spessore Thickness mm. |
| O 31 25 003 | | 25 | 1,5 |
| O 31 30 003 | | 30 | 2,0 |



NYLON

Tappo per tubo **Plug for pipe**
 Fabbricato in nylon grigio. **Manufactured in grey nylon.**

| Articolo - Item | €/pc. | €/box | Ø mm. | kg. |
|-----------------|-------|-------|-------|-------|
| S 20 00 025 | | | 25 | 0,025 |



Candelieri corrimano Aisi 316 **Aisi 316 stanchion**

| Foro centrale e superiore Ø 10 mm. | | Ø 10 mm. holes. | |
|------------------------------------|-------|-----------------|------------|
| Articolo - Item | €/pc. | Ø mm. | Length mm. |
| S 08 25 465 | | 25 | 465 |



Base in alluminio per corrimano e tientibene foro Ø 25 mm. **Aluminium connector for hand rail hole Ø 25 mm.**

| Fabbricata in alluminio anodizzato argento. Manufactured in silver anodised aluminium. | | Provvista di fori per il fissaggio. With fixing holes. | |
|---|-------|---|-------------------|
| Articolo - Item | €/pc. | €/box | A mm. B mm. C mm. |
| N 43 25 055 | | | 25 60 60 |

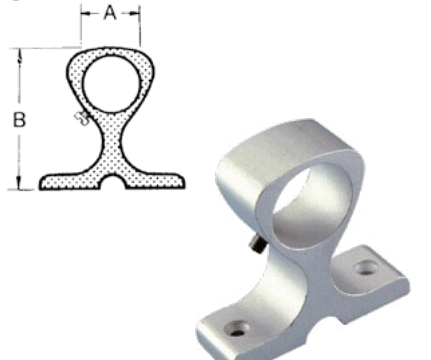

Pulpito di poppa in acciaio inox Aisi 316 **Hand rail in Aisi 316 stainless steel**

| Tubo Ø 25 mm. | | Pipe Ø 25 mm. | |
|-----------------|-------|---------------|-------|
| Articolo - Item | €/pc. | H. mm. | kg. |
| S 08 31 008 | | H. 740 x 325 | 1,620 |



Corrimano tubo Ø 25 mm.

Fabbricato in acciaio inox.

| Articolo - Item | €/pc. | H. mm. | kg. |
|-----------------|-------|-----------|-------|
| S 08 25 085 | | 800 x 300 | 1,500 |



Dock hand rail Ø 25 mm.

Manufactured in stainless steel.



AISI 316

Cavo in acciaio inox «7x7» (49 fili)

Cavetto in acciaio inox Aisi 316.

Stainless steel wire rope «7x7» (49 wires)

Wire made of Aisi 316 stainless steel.

| Articolo - Item | €/mt. | €/ | Ø mm. | mt. | kg. |
|-----------------|-------|----|-------|-----|--------|
| N 04 08 007 | | | 8 | 100 | 26,400 |

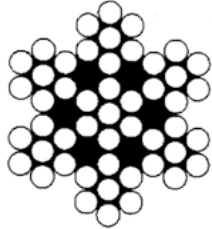

AISI 316

Cavo in acciaio inox Aisi 316 «7x19» (133 fili)

Aisi 316 stainless steel wire rope «7x19» (133 wires)

| Articolo - Item | €/mt. | €/ | Ø mm. | mt. | kg. |
|-----------------|-------|----|-------|-----|-------|
| N 04 15 133 | | | 1,5 | 100 | 0,960 |
| N 04 03 133 | | | 3 | 100 | 3,520 |

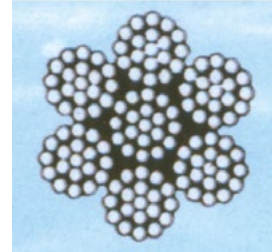

Cavo parafil

Fili in "Terylene" continuo, rivestito da una guaina bianca in alcatene.

Guardrail cable

Made of "Terylene" continuous yarn, coated with white alcatene sheath.

| Articolo - Item | €/mt. | €/ | Ø mm. | mt. | kg. |
|-----------------|-------|----|-------|-----|------|
| N 04 16 506 | | | 7 | 300 | 510 |
| N 04 16 508 | | | 8,5 | 300 | 1015 |



Pinza tagliacavi

Lame in acciaio. Manico in acciaio trattato a caldo. Lame rimovibili.

Wire rope cutter

Drop forged alloy steel blades. Heavy duty heat treated steel handle. Changeable blades.

| Articolo - Item | €/pc. | Cavo-Cable Ø mm. | Length mm. | kg. |
|-----------------|-------|------------------|------------|-------|
| F 02 14 600 | | 10-14 | 600 | 2,600 |
| F 02 18 900 | | 14-18 | 900 | 5,000 |



Pinza impiombatrice

Parte pieghettata fabbricata in una particolare lega d'acciaio temprato. Manico in acciaio trattato a caldo.

Multi groove climper

Crimping part made from special hardened alloy steel. Heavy duty heat treated steel handle.

| Articolo - Item | €/pc. | Per Manicotti For sleeves | Length mm. | kg. |
|-----------------|-------|---------------------------|------------|-------|
| N 58 05 096 | | 4-6-8-10 | 500 | 2,500 |

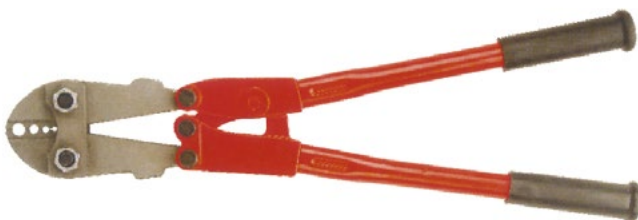

Attrezzo per impiombature modello per manicotti circolari

Tool suitable for sealing

| Articolo - Item | €/pc. | Indicato per cavi acciaio Suitable for steel wires Ø mm. | mm. |
|-----------------|-------|--|----------------|
| F 00 06 000 | | 2 - 6 | 210 x 140 x 20 |

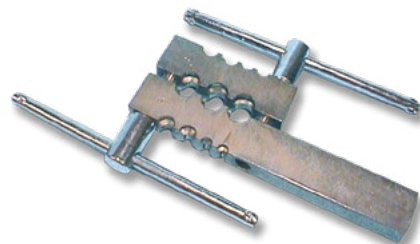

AISI 316

Terminali per cavi modello ad occhio

Terminali per impiombature inox con bloccaggio a doppio cono. Adatti per cavi preformati sia rigidi che flessibili, non richiedono nessun attrezzo per il montaggio.

End fittings for cable with eye

Fitted with double locking cones; suitable for preformed cables, either rigid or flexible; no special tools are required for the installation.

| Articolo - Item | €/pc. | Per cavi For wires Ø mm. | A mm. | B mm. | L mm. | kg. |
|-----------------|-------|-----------------------------|-------|-------|-------|-------|
| N 67 04 055 | | 4 | 8,2 | 6,5 | 65 | 0,060 |

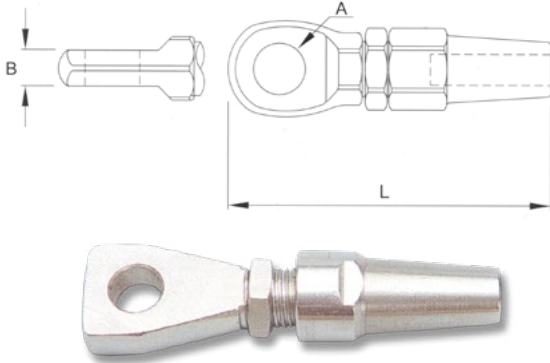

AISI 316

Terminali per cavi modello a forcella

Terminali per impiombature inox con bloccaggio a doppio cono. Adatti per cavi preformati sia rigidi che flessibili, non richiedono nessun attrezzo per il montaggio.

End fittings for cable with fork

Fitted with double locking cones; suitable for preformed cables, either rigid or flexible; no special tools are required for the installation.

| Articolo - Item | €/pc. | Per cavi For wires Ø mm. | A mm. | B mm. | L mm. | kg. |
|-----------------|-------|-----------------------------|-------|-------|-------|-------|
| N 59 08 100 | | 8 | 14,8 | 13,3 | 117 | 0,350 |

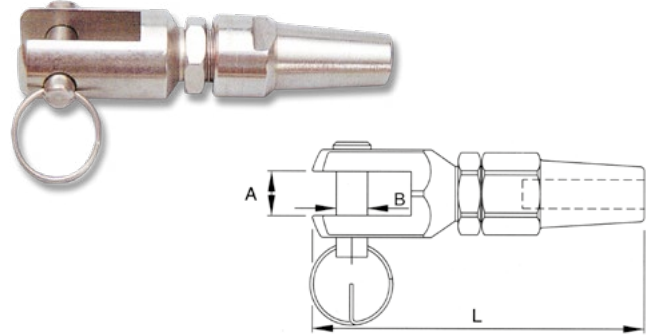

AISI 316

Gancio «Pelican» in acciaio inox Aisi 316

Aisi 316 stainless steel «Pelican» hook

| Articolo - Item | €/pc. | Ø mm. | kg. |
|-----------------|-------|-------|-------|
| N 67 06 130 | | 6 | 0,070 |
| N 67 08 130 | | 8 | 0,130 |



AISI 316

Terminali per cavi d'acciaio modello a forcella

Ideale per Parafil.

End fittings for stainless steel cable with fork

Suitable for Parafil.

| Articolo - Item | €/pc. | Per cavi For wires Ø mm. | A mm. | B mm. | L mm. | kg. |
|-----------------|-------|-----------------------------|-------|-------|-------|-------|
| N 59 09 075 | | 9 | 7 | 6 | 78 | 0,060 |

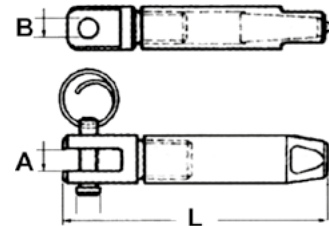

AISI 316

Anellini per perni tenditori in acciaio inox Aisi 316

Aisi 316 stainless steel rings

| Articolo - Item | €/pc. | €/box | Ø mm. | kg. |
|-----------------|-------|-------|-------|-------|
| N 64 11 000 | | | 11 | 0,002 |
| N 64 15 000 | | | 15 | 0,008 |
| N 64 19 000 | | | 19 | 0,010 |
| N 64 23 000 | | | 23 | 0,025 |



AISI 316

Tenditore a due forcelle

Fabbricato in acciaio inox Aisi 316. Finitura accurata con filetti scorrevoli per una buona regolazione del tenditore.

Rigging screw with double fork

Aisi 316 stainless steel. Very accurate finishing for a good adjustment of the screw.

| Articolo - Item | €/pc. | Ø vite mm. | A mm. | B mm. | C mm. | D mm. | kg. | kg. |
|-----------------|-------|------------|-------|-------|-------|-------|------|-------|
| N 60 06 200 | | 6 | 210 | 155 | 10 | 6 | 1250 | 0,080 |
| N 60 08 240 | | 8 | 225 | 165 | 12 | 6 | 1750 | 0,170 |
| N 60 10 270 | | 10 | 270 | 180 | 17 | 8 | 3500 | 0,280 |

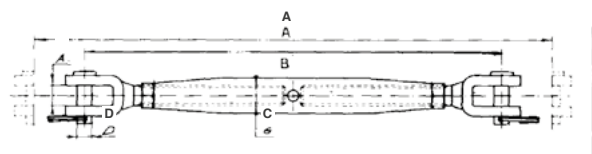

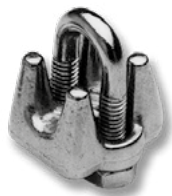

AISI 316

Morsetto a cavallotto

Wire rope clip

In acciaio inox Aisi 316.

Aisi 316 stainless steel.

| Articolo - Item | €/pc. | €/box | Per - For Ø mm. | Filetto | kg. |
|-----------------|-------|-------|-----------------|---------|-------|
| M 19 02 000 | | | 1,5 - 2 | M3 | 0,060 |
| M 19 03 000 | | | 2 - 3 | M3 | 0,066 |
| M 19 04 000 | | | 3 - 4 | M4 | 0,060 |
| M 19 06 000 | | | 5 - 6 | M5 | 0,126 |
| M 19 08 000 | | | 7 - 8 | M6 | 0,216 |



Manicotto

Splicing sleeve

| Articolo - Item | €/pc. | €/box | Articolo - Item | €/pc. | €/box | Cavo Cable Ø mm. |
|-----------------|-------|-------|-----------------|-------|-------|------------------|
| ALU | | | RAME-COPPER | | | |
| - | | | M 10 02 002 | | | 2 |
| - | | | M 10 03 002 | | | 3 |
| - | | | M 10 04 002 | | | 4 |
| - | | | M 10 05 002 | | | 5 |
| M 10 06 031 | | | M 10 06 002 | | | 6 |



AISI 316

Ponticelli

Fastening clamps

In acciaio inox Aisi 316.

Aisi 316 stainless steel.

| Articolo - Item | €/pc. | €/box | L mm. | L1 mm. | A mm. | H mm. | kg. |
|-----------------|-------|-------|-------|--------|-------|-------|-------|
| N 34 35 012 | | | 37 | 27 | 9 | 13 | 0,200 |
| N 34 43 014 | | | 43 | 32 | 12 | 14 | 0,200 |
| N 34 65 018 | | | 54 | 39 | 14 | 21 | 0,400 |

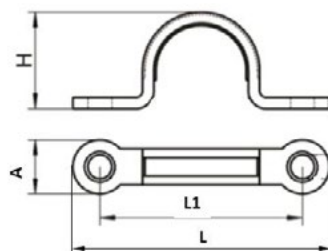

AISI 316

Morsetto per cavo

Wire rope clip

In acciaio inox Aisi 316.

Aisi 316 stainless steel.

| Articolo - Item | €/pc. | €/box | Per cavi For wires Ø mm. | Ø est. mm. outer Ø mm. | mm. | kg. |
|-----------------|-------|-------|--------------------------|------------------------|-----|-------|
| M 19 03 908 | | | 3 | 20 | 19 | 0,360 |
| M 19 04 908 | | | 4 | 20 | 21 | 0,370 |



AISI 316

Corrimano in tubo ovalizzato Oval handrail

In acciaio inox lucidato a specchio.

Made of mirror polished stainless steel.

| Articolo - Item | €/pc. | L1 mm. | L mm. | H mm. | Fissaggio-Fastening |
|-----------------|-------|--------|-------|-------|-----------------------|
| N 43 25 300 | | 300 | 330 | 65 | 2 Prigionieri Ø 8 mm. |
| N 43 18 400 | | 405 | 440 | 58 | 2 Prigionieri Ø 8 mm. |
| N 43 08 300 | | 460 | 490 | 58 | 2 Prigionieri Ø 8 mm. |
| N 43 18 500 | | 500 | 530 | 58 | 2 Prigionieri Ø 8 mm. |
| N 43 08 400 | | 600 | 630 | 58 | 2 Prigionieri Ø 8 mm. |
| N 43 25 500 | | 580 | 610 | 58 | 2 Prigionieri Ø 8 mm. |

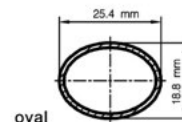
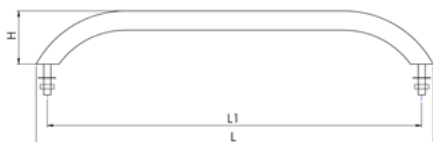

AISI 316

Corrimano in tubo ovalizzato Oval handrail

In acciaio inox lucidato a specchio.
Fissaggio esterno con viti.

Made of mirror polished stainless steel.

| Articolo - Item | €/pc. | L1 mm. | L+A mm. | H mm. | N. fori di fissaggio Fastening holes |
|-----------------|-------|--------|---------|-------|--------------------------------------|
| N 43 43 305 | | 305 | 337 | 55 | 4 |
| N 43 43 407 | | 440 | 408 | 55 | 4 |
| N 43 43 460 | | 490 | 455 | 55 | 4 |

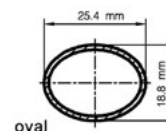
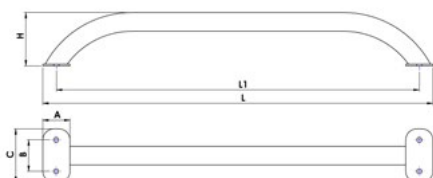

AISI 316

Corrimano in tubo ovalizzato Oval handrail

In acciaio inox.

Made of stainless steel.

| Articolo - Item | €/pc. | L1 mm. | L mm. | H mm. | Fissaggio-Fastening |
|-----------------|-------|--------|-------|-------|-----------------------|
| N 43 44 220 | | 195 | 220 | 60 | 2 Prigionieri Ø 8 mm. |
| N 43 44 305 | | 280 | 305 | 60 | 2 Prigionieri Ø 8 mm. |
| N 43 44 407 | | 382 | 407 | 60 | 2 Prigionieri Ø 8 mm. |
| N 43 44 460 | | 435 | 460 | 60 | 2 Prigionieri Ø 8 mm. |
| N 43 44 600 | | 575 | 600 | 60 | 2 Prigionieri Ø 8 mm. |

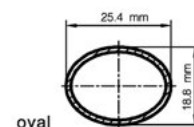

AISI 316

Corrimano in tubo ovalizzato Oval handrail

In acciaio inox.

Made of stainless steel.

| Articolo - Item | €/pc. | ↳ Tubo-Pipe mm. | L mm. | H mm. | Fissaggio Fastening |
|-----------------|-------|--------------------|-------|-------|---------------------|
| N 43 33 305 | | 13 x 33 | 305 | 59 | Filetto M6 |
| N 43 33 457 | | 13 x 33 | 457 | 59 | Filetto M6 |
| N 43 33 610 | | 13 x 33 | 610 | 59 | Filetto M6 |
| N 43 40 457 | | 20 x 40 | 457 | 59 | Filetto M6 |
| N 43 40 610 | | 20 x 40 | 610 | 59 | Filetto M6 |
| N 43 40 762 | | 20 x 40 | 762 | 59 | Filetto M6 |
| N 43 40 915 | | 20 x 40 | 915 | 59 | Filetto M6 |



AISI 316

Corrimano in acciaio inox Aisi 316 Stainless steel Aisi 316 hand rail

| Articolo - Item | €/pc. | Length mm. | H mm. | Tubo-Pipe Ø mm. | Base Ø mm. |
|-----------------|-------|------------|-------|-----------------|------------|
| N 43 42 200 | | 200 | 60 | 22 | 60 |
| N 43 42 300 | | 300 | 70 | 22 | 60 |
| N 43 42 500 | | 500 | 75 | 22 | 60 |
| N 43 42 800 | | 800 | 80 | 22 | 60 |



NEW



AISI 316

Maniglia in acciaio Aisi 316

In acciaio inox microfuso Aisi 316 lucidato a specchio.

Aisi 316 Handrail

Made of Aisi 316 mirror polished stainless steel.

| Articolo - Item | €/pc. | L mm. | L1 mm. | H mm. | Fissaggio Fastening | Prigionieri OPTIONAL |
|-----------------|-------|-------|--------|-------|-----------------------|----------------------|
| N 43 40 170 | | 170 | 140 | 40 | 2 Prigionieri Ø 8 mm. | N3008090 |
| N 43 40 172 | | 170 | 140 | 40 | 2 viti-screws | - |
| N 43 40 300 | | 300 | 280 | 50 | 2 Prigionieri Ø 8 mm. | N3008090 |
| N 43 40 302 | | 300 | 280 | 50 | 2 viti-screws | - |

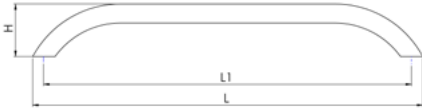

AISI 316

Maniglione tientibene

In acciaio inox Aisi 316.

Handrail

Manufactured in Aisi 316 stainless steel.

| Articolo - Item | €/pc. | Ø mm. | Length mm. | H mm. | pcs. | kg. |
|-----------------|-------|-------|------------|-------|------|-------|
| N 43 22 045 | | 22 | 300 | 80 | 30 | 0,290 |
| N 43 22 065 | | 22 | 500 | 80 | 30 | 0,420 |
| N 43 22 085 | | 22 | 800 | 80 | 30 | 0,600 |
| N 43 32 030 | | 25 | 300 | 80 | 30 | 0,400 |
| N 43 32 050 | | 25 | 500 | 80 | 30 | 0,500 |
| N 43 32 085 | | 25 | 850 | 80 | 30 | 0,600 |



Maniglia tientibene

In alluminio.

Handrail

Made of aluminium.

| Articolo - Item | €/pc. | L mm. | L1 mm. | H mm. | Filetto-Thread | kg. |
|-----------------|-------|-------|--------|-------|----------------|-------|
| N 43 33 600 | | 590 | 520 | 40 | M6 | 0,150 |

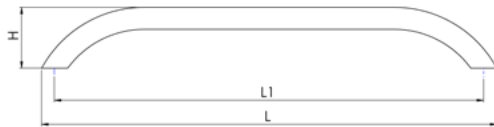

Maniglia tientibene

Filetto M6.

Modello fabbricato in alluminio anodizzato con terminali in plastica antiurto.

Handrail

Thread M6.

Made of anodised aluminium with shockproof plastic end fittings.

| Articolo - Item | €/pc. | Colore terminale End fitting colour | L mm. | L1 mm. | H mm. | kg. |
|-----------------|-------|-------------------------------------|-------|--------|-------|-------|
| N 43 31 400 | | | 400 | 360 | 40 | 0,150 |
| N 43 31 550 | | | 590 | 550 | 40 | 0,150 |

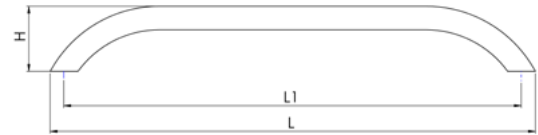

Maniglia in PVC morbido

Con tappo copriviti.

Handrail in soft PVC

With covered screws.

| Articolo - Item | €/pc. | Colore Colour | Length mm. | H mm. | Interasse mm. | Fori-Holes Ø mm. |
|-----------------|-------|---------------|------------|-------|---------------|------------------|
| N 38 74 246 | | | 205 | 55 | 154 | 7 |
| N 38 79 246 | | Ral 7035 | 205 | 55 | 154 | 7 |



Maniglia in PVC rigido

Montaggio con viti passanti a scomparsa.

Handrail in rigid PVC

With covered screws.

| Articolo - Item | €/pc. | Colore Colour | Length mm. | H mm. | Interasse mm. |
|-----------------|-------|---------------|------------|-------|---------------|
| N 38 79 250 | | Ral 7035 | 250 | 60 | 195 |



CERNIERE | HINGES

Cerniera inox con lamiera adesiva | Stainless steel hinge with adhesive plate

| Articolo - Item | €/pc. | ↳ mm. | 📦 kg. |
|-----------------|-------|---------|-------|
| M 35 36 057 | | 59x40x2 | 0,080 |

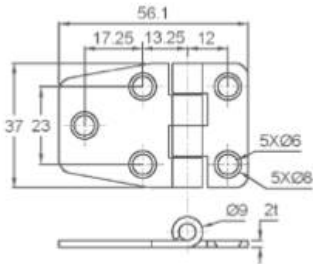

Cerniera inox con lamiera adesiva | Stainless steel hinge with adhesive plate

| Articolo - Item | €/pc. | ↳ mm. | 📦 kg. |
|-----------------|-------|---------|-------|
| M 35 37 076 | | 76x40x2 | 0,100 |

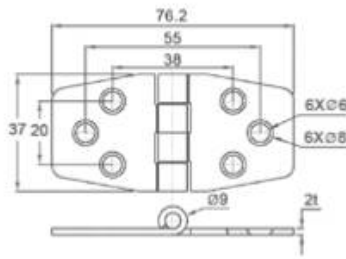

Cerniera inox con lamiera adesiva | Stainless steel hinge with adhesive plate

| Articolo - Item | €/pc. | ↳ mm. | 📦 kg. |
|-----------------|-------|---------|-------|
| M 35 40 040 | | 40x40x2 | 0,050 |

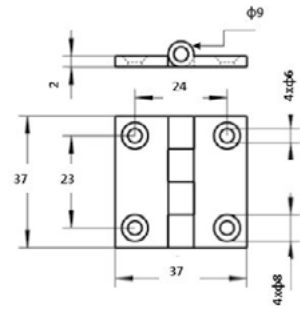

Cerniera inox con lamiera adesiva | Stainless steel hinge with adhesive plate

| Articolo - Item | €/pc. | ↳ mm. | 📦 kg. |
|-----------------|-------|---------|-------|
| M 35 65 065 | | 65x65x2 | 0,060 |

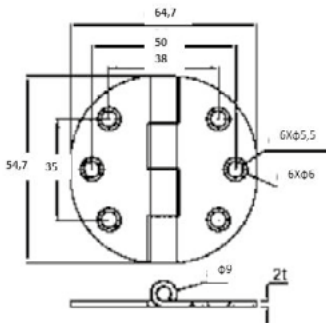

Cerniera inox | Stainless steel hinge

| Articolo - Item | €/pc. | ↳ mm. | 📦 kg. |
|-----------------|-------|-------|-------|
| M 35 57 076 | | 76x57 | 0,290 |



Cerniera a scomparsa in ottone | Brass hinge

| Articolo - Item | €/pc. | 📦 kg. |
|-----------------|-------|-------|
| M 35 30 065 | | 0,090 |

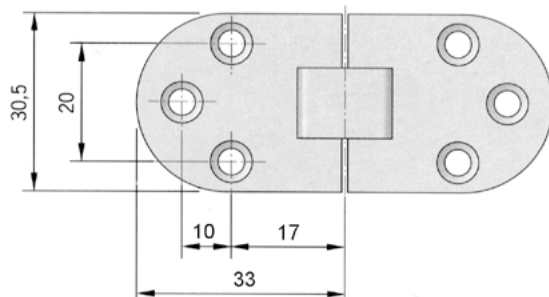
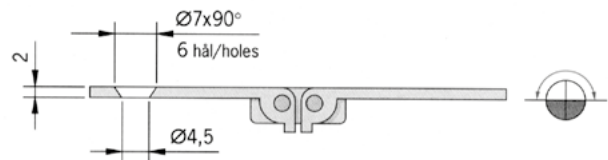
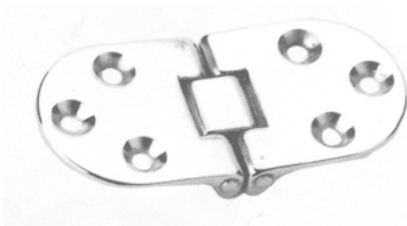

CERNIERE | HINGES

Cerniera inox Stainless steel hinge

| Articolo - Item | €/pc. | €/box | H mm. | kg. |
|-----------------|-------|-------|-------|-------|
| M 35 52 576 | | | 12 | 0,150 |

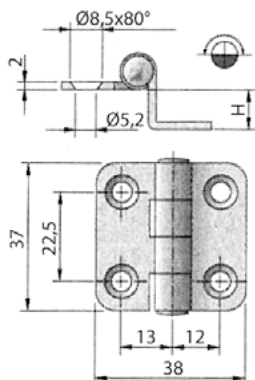

Cerniera inox Stainless steel hinge

| Articolo - Item | €/pc. | €/box | H mm. | kg. |
|-----------------|-------|-------|-------|-------|
| M 35 52 577 | | | 10 | 0,330 |

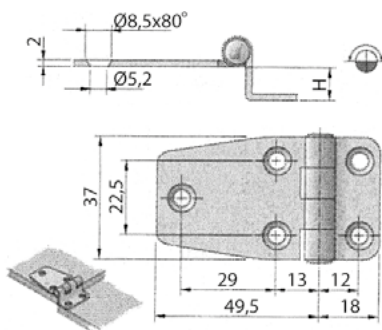

Cerniera inox Stainless steel hinge

| Articolo - Item | €/pc. | €/box | mm. | kg. |
|-----------------|-------|-------|-------|-------|
| M 35 40 070 | | | 70x40 | 0,310 |



Cerniera inox Stainless steel hinge

| Articolo - Item | €/pc. | Mod. | kg. |
|-----------------|-------|-----------------|-------|
| M 35 52 565 | | Dritto-Straight | 0,040 |

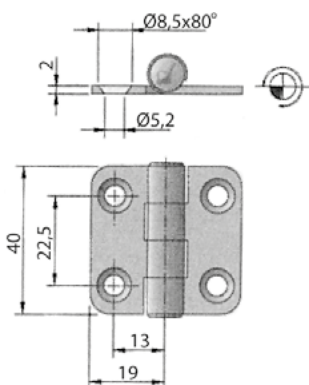

Cerniera inox Stainless steel hinge

| Articolo - Item | €/pc. | €/box | Mod. | kg. |
|-----------------|-------|-------|-----------------|-------|
| M 35 52 570 | | | Dritto-Straight | 0,318 |

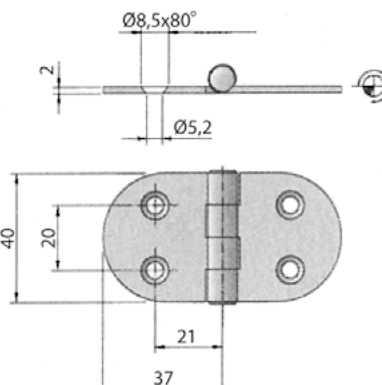

Cerniera inox Stainless steel hinge

| Articolo - Item | €/pc. | €/box | Mod. | kg. |
|-----------------|-------|-------|-----------------|-------|
| M 35 01 490 | | | Dritto-Straight | 0,312 |

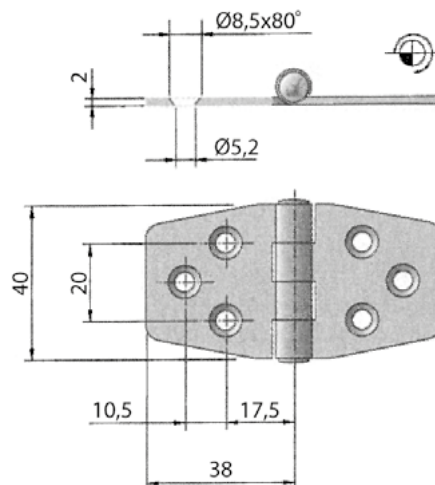

Cerniera inox Stainless steel hinge

| Articolo - Item | €/pc. | €/box | Mod. | kg. |
|-----------------|-------|-------|-----------------|-------|
| M 35 75 037 | | | Dritto-Straight | 0,360 |

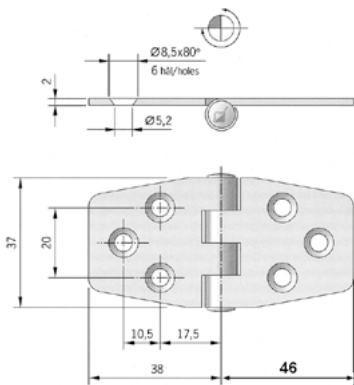

Cerniera inox Stainless steel hinge

| Articolo - Item | €/pc. | €/box | H mm. | Length mm. | Fori Holes | kg. |
|-----------------|-------|-------|-------|------------|------------|-------|
| M 35 60 030 | | | 40 | 40 | 4 | 0,050 |
| M 35 60 040 | | | 60 | 40 | 6 | 0,060 |

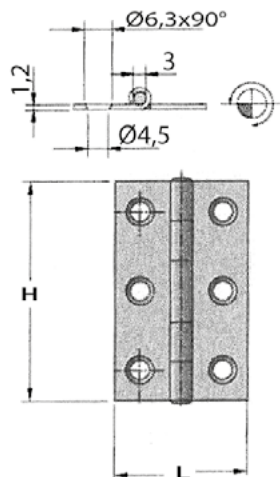

Cerniera ideale Hinge for rubber boats per gommoni boats

| Articolo - Item | €/pc. | mm. | kg. |
|-----------------|-------|-------|-------|
| M 35 65 045 | | 65x45 | 0,070 |



CERNIERE | HINGES

Cerniera inox Stainless steel hinge

| Articolo - Item | €/pc. | Mod. | kg. |
|-----------------|-------|-----------------|-------|
| M 35 44 080 | | Dritto-Straight | 0,080 |

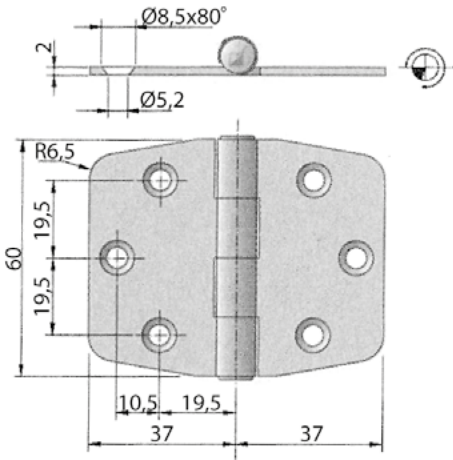

Cerniera inox Stainless steel hinge

| Articolo - Item | €/pc. | Mod. | kg. |
|-----------------|-------|-----------------|-------|
| M 35 52 585 | | Dritto-Straight | 0,080 |

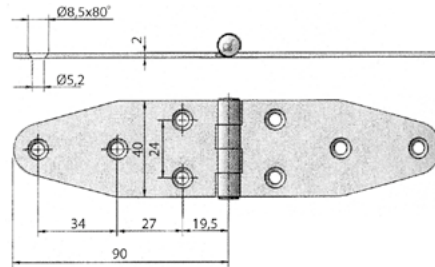

Cerniera inox Stainless steel hinge

| Articolo - Item | €/pc. | Mod. | kg. |
|-----------------|-------|-----------------|-------|
| M 35 06 091 | | Dritto-Straight | 0,100 |

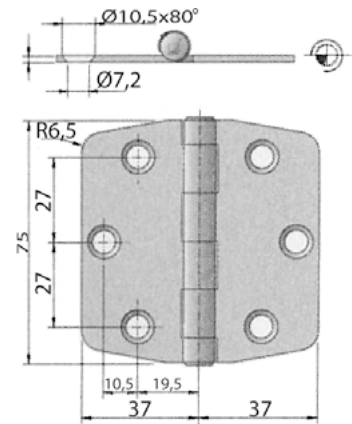

Cerniera inox Stainless steel hinge

| Articolo - Item | €/pc. | €/box | Mod. | kg. |
|-----------------|-------|-------|-----------------|-------|
| M 35 01 500 | | | Dritto-Straight | 0,258 |

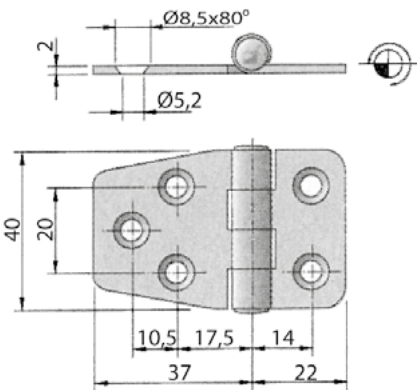

Cerniera inox Stainless steel hinge

| Articolo - Item | €/pc. | €/box | Mod. | kg. |
|-----------------|-------|-------|-----------------|-------|
| M 35 02 720 | | | Dritto-Straight | 0,240 |

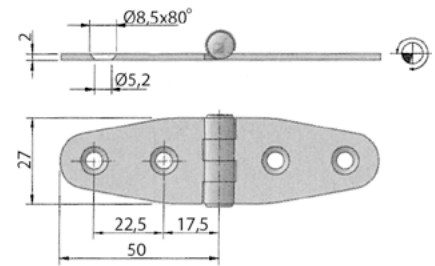

Cerniera inox Stainless steel hinge

| Articolo - Item | €/pc. | €/box | Mod. | kg. |
|-----------------|-------|-------|-----------------|-------|
| M 35 37 035 | | | Dritto-Straight | 0,288 |

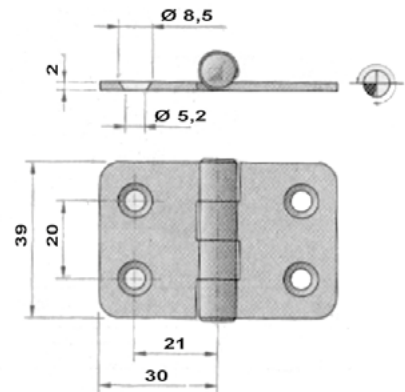

Cerniera inox Stainless steel hinge

| Articolo - Item | €/pc. | Mod. | kg. |
|-----------------|-------|-----------------|-------|
| M 35 01 720 | | Dritto-Straight | 0,080 |

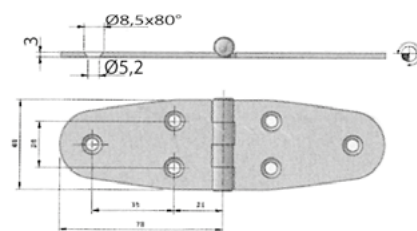

Cerniera inox Stainless steel hinge

| Articolo - Item | €/pc. | €/box | H mm. | Length mm. | kg. |
|-----------------|-------|-------|-------|------------|-------|
| M 35 01 040 | | | 50 | 40 | 0,084 |

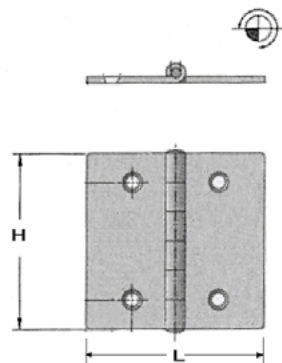

Cerniera inox Stainless steel hinge

| Articolo - Item | €/pc. | H mm. | Length mm. | kg. |
|-----------------|-------|-------|------------|-------|
| M 35 10 040 | | 40 | 100 | 0,070 |



AISI 304

Cerniera girevole con portalucchetto Swivel hinge

In acciaio inox Aisi 304. In Aisi 304 stainless steel.

| Articolo - Item | €/pc. | mm. | kg. |
|-----------------|-------|-------|-------|
| M 35 01 070 | | 70x25 | 0,050 |
| M 35 25 070 | | 95x25 | 0,050 |



AISI 304

Cerniera fissa con portalucchetto Fixed hinge

In acciaio inox Aisi 304. In Aisi 304 stainless steel.

| Articolo - Item | €/pc. | mm. | kg. |
|-----------------|-------|-------|-------|
| M 35 00 070 | | 70x25 | 0,050 |
| M 35 24 070 | | 95x25 | 0,050 |



AISI 316

Cerniera girevole Swivel hinge

Fabbricata in cera persa Aisi 316. In Aisi 316 stainless steel.

| Articolo - Item | €/pc. | mm. | kg. |
|-----------------|-------|-------|-------|
| M 35 90 275 | | 75x25 | 0,110 |



Chiusura con serratura Locking hinge

In acciaio inox Aisi 304. In Aisi 304 stainless steel.

| Articolo - Item | €/pc. | mm. | kg. |
|-----------------|-------|-------|-------|
| M 35 00 199 | | 76x30 | 0,090 |

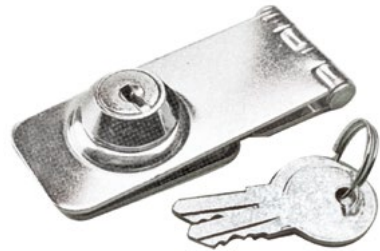

AISI 316

Ferma porta Door holder

In acciaio inox Aisi 316. In Aisi 316 stainless steel.

| Articolo - Item | €/pc. | mm. | kg. |
|-----------------|-------|--------------|-------|
| M 35 25 028 | | 26,5x28x38 H | 0,050 |
| M 35 38 035 | | 40x32x40 H | 0,100 |



AISI 316

Cerniera per portelli Hatches hinge

In acciaio inox Aisi 316. In Aisi 316 stainless steel.
Ingombro chiusa 57x30 mm. Size when closed 57x30 mm.
Fissaggio a parete 26x30 mm. Wall fixing 26x30 mm.
Fissaggio su anta 31x30 mm. Door fixing 31x30 mm.

| Articolo - Item | €/pc. | mm. | H mm. | kg. |
|-----------------|-------|-------|-------|-------|
| M 35 30 057 | | 57x30 | 10 | 0,100 |



AISI 316

Ferma porta e finestra Door lock and bottom board lock

Realizzato in acciaio inox Aisi 316. Aisi 316 stainless steel.
Provvisto di copertura in plastica per non danneggiare la porta o la finestra. With plastic covering to prevent any damage of doors and windows.

| Articolo - Item | €/pc. | A mm. | B mm. | C mm. | D mm. | kg. |
|-----------------|-------|-------|-------|-------|-------|-------|
| N 30 80 186 | | 73 | 48 | 19 | 40 | 0,090 |

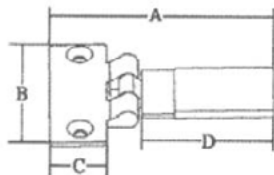
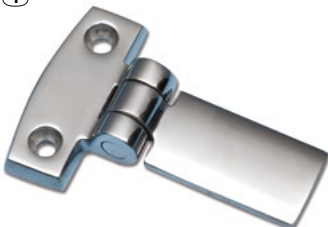

AISI 304

Chiusura per sportelli Hatch lock fastener

Realizzato in acciaio inox Aisi 304. Aisi 304 stainless steel.

| Articolo - Item | €/pc. | Length mm. | Foro - Hole Ø mm. | kg. |
|-----------------|-------|------------|-------------------|-------|
| M 35 00 058 | | 58 | 21 | 0,150 |

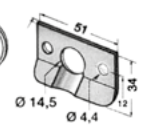
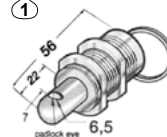

AISI 316

Chiusura

In acciaio inox AISI 316 con foro per lucchetto.

Door lock

In Aisi 316 stainless steel with hole for padlock.

| Articolo - Item | €/pc. |
|-----------------|-------|
| M 35 01 102 | |

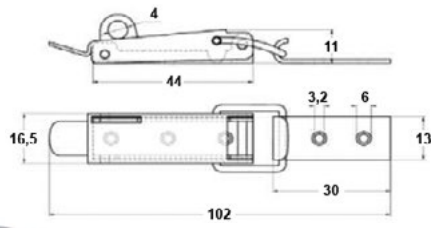

AISI 316

Chiusura

In acciaio inox AISI 316 senza porta lucchetto.

Door lock

In Aisi 316 stainless steel without hole for padlock.

| Articolo - Item | €/pc. |
|-----------------|-------|
| M 35 00 102 | |

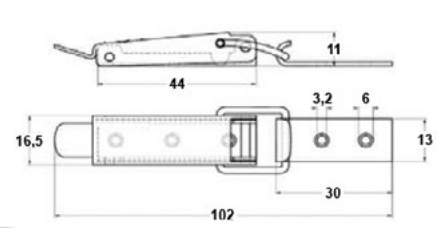

AISI 316

Chiusura

In acciaio inox con foro per lucchetto.

Door lock

In Aisi 316 stainless steel with hole for padlock.

| Articolo - Item | €/pc. |
|-----------------|-------|
| M 35 08 053 | |

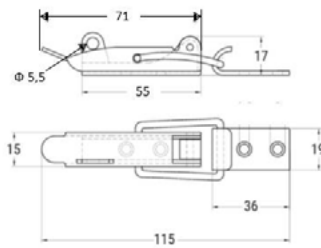

AISI 316

Chiusura

In acciaio inox con foro per lucchetto.

Door lock

In Aisi 316 stainless steel with hole for padlock.

| Articolo - Item | €/pc. |
|-----------------|-------|
| M 35 00 115 | |

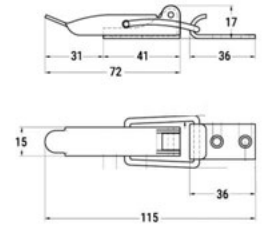

AISI 316

Chiusura regolabile

In acciaio inox con foro per lucchetto.

Adjustable door lock

In Aisi 316 stainless steel with hole for padlock.

| Articolo - Item | €/pc. | A mm. | B mm. | C mm. |
|-----------------|-------|-------|-------|-------|
| M 35 32 095 | | 98 | 26 | 22 |
| M 35 32 125 | | 155 | 40 | 45 |

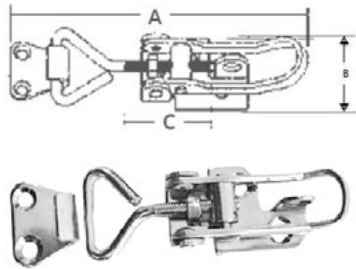

AISI 316

Chiusura

In acciaio inox Aisi 316 con portallucchetto.

Door lock

In Aisi 316 stainless steel with padlock holder.

| Articolo - Item | €/pc. | A mm. | B mm. | C mm. |
|-----------------|-------|-------|-------|-------|
| M 35 00 210 | | 100 | 46 | 75 |



AISI 316

Chiusura in acciaio stampato Aisi 316

Aisi 316 stainless steel fastening

| Articolo - Item | €/pc. | mm. | kg. |
|-----------------|-------|-------|-----|
| M 35 92 253 | | 52x42 | |

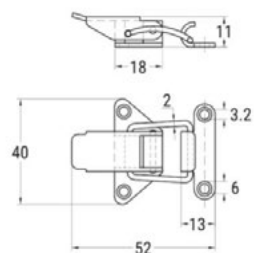

AISI 316

Cerniera regolabile in acciaio inox Aisi 316

Aisi 316 stainless steel adjustable hinge

| Articolo - Item | €/pc. | mm. | kg. |
|-----------------|-------|--------|-------|
| M 35 30 120 | | 120x30 | 0,200 |



Maniglia alza pagliolo

Realizzato in ABS.

Flush handle

Manufactured in ABS.

| Articolo - Item | €/pc. | mm. | Colore - Colour | kg. |
|-----------------|-------|--------------------|-------------------|-------|
| N 30 44 033 | | L 57 x H 57 x Ø 44 | Crema-Cream 9010 | 0,030 |
| N 30 44 074 | | L 57 x H 57 x Ø 44 | Bianco-White 9003 | 0,030 |



AISI 316

Maniglia a scatto

In acciaio inox Aisi 316.

Flush-pull latch

In Aisi 316 stainless steel.

| Articolo - Item | €/pc. | Foro-Hole Ø mm. | Spessore Depth mm. | kg. |
|-----------------|-------|-----------------|--------------------|-------|
| D 53 80 284 | | 50 | 8-14 | 0,210 |



AISI 316

Fermapagliolo

In acciaio inox Aisi 316.

Bottom board lock

In Aisi 316 stainless steel.

| Articolo - Item | €/pc. | Ø mm. | kg. |
|-----------------|-------|-------|-------|
| N 30 45 000 | | 45 | 0,050 |



AISI 316

Alzapagliolo

In acciaio inox Aisi 316.

Bottom board lifting device

In Aisi 316 stainless steel.

| Articolo - Item | €/pc. | A mm. | B mm. | kg. |
|-----------------|-------|-------|-------|-------|
| N 30 56 066 | | 66 | 56 | 0,040 |

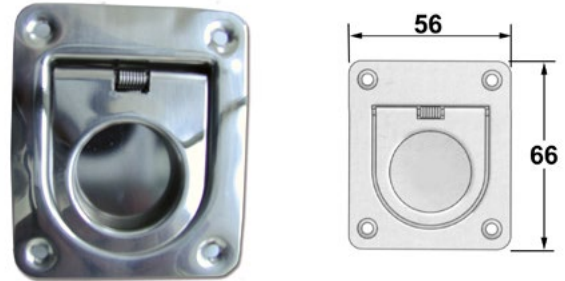

AISI 316

Fermapagliolo

In acciaio inox Aisi 316.

Bottom board lock

In Aisi 316 stainless steel.

| Articolo - Item | €/pc. | Ø mm. | kg. |
|-----------------|-------|-------|-------|
| N 30 60 000 | | 60 | 0,040 |



AISI 316

Gancio appendiabiti a scomparsa

In acciaio inox Aisi 316.

Folding coat hanger

In Aisi 316 stainless steel.

| Articolo - Item | €/pc. | mm. | kg. |
|-----------------|-------|-------|-------|
| M 35 95 050 | | 75x25 | 0,080 |



AISI 316

Maniglia a scatto con apertura interna

Flush-pull latch with inner opening system

| Articolo - Item | €/pc. | Ø esterno-outer mm. | Ø interno-inner mm. | D mm. | H mm. | Mod. | kg. |
|-----------------|-------|---------------------|---------------------|-------|-------|----------------------------|-------|
| D 53 80 264 | | 62 | 50 | 5-20 | 38 | Senza serratura-W/out lock | 0,200 |
| D 53 80 265 | | 62 | 50 | 5-20 | 38 | Con serratura-With lock | 0,240 |

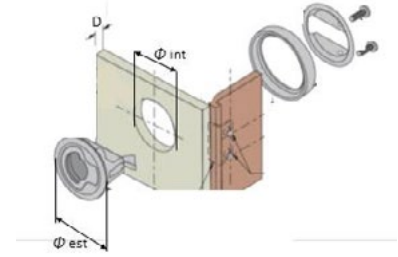

AISI 316

Maniglia a scatto con apertura interna

Flush-pull latch with inner opening system

| Articolo - Item | €/pc. | Ø esterno-outer mm. | Ø interno-inner mm. | D mm. | H mm. | Mod. | kg. |
|-----------------|-------|---------------------|---------------------|-------|-------|----------------------------|-------|
| D 53 12 063 | | 62 | 50 | 12-18 | 38 | Senza serratura-W/out lock | 0,200 |
| D 53 12 064 | | 62 | 50 | 12-18 | 38 | Con serratura-With lock | 0,220 |

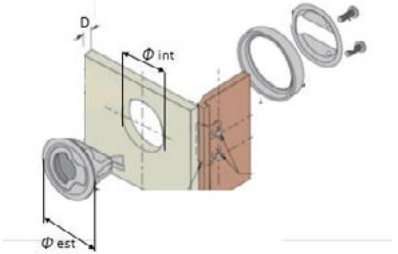

AISI 316

Maniglia a leva

Lift handle

| Articolo - Item | €/pc. | Ø esterno-outer mm. | Ø interno-inner mm. | D mm. | H mm. | Mod. | kg. |
|-----------------|-------|---------------------|---------------------|-------|-------|--|-------|
| D 53 60 204 | | 62 | 50 | 0-20 | 66 | Senza serratura-W/out lock | 0,220 |
| D 53 60 205 | | 62 | 50 | 0-20 | 66 | Con serratura-With lock | 0,250 |
| D 53 60 204H | | 62 | 50 | 0-20 | 66 | Senza serratura con leva-W/out lock with lever | |



D5360204



D5360205



D5360204H

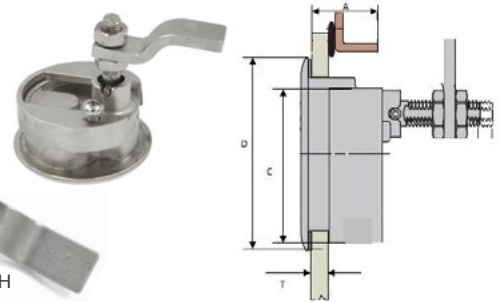

Maniglia a scatto con apertura anche interna

In ABS antiurto (Patent Pending).

Flush-pull latch with inner opening system

In shockproof ABS (Patent Pending).

| Articolo - Item | €/pc. | Ø esterno-outer mm. | Ø interno-inner mm. | D mm. | H mm. | kg. |
|-----------------|-------|---------------------|---------------------|-------|-------|-------|
| N 30 50 018 | | 61 | 48 | 3-10 | 38 | 0,040 |

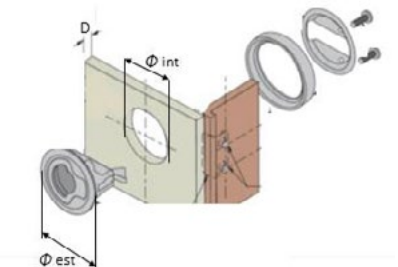

Appendiabiti a scomparsa

In ottone cromato.
Provvisto di molla inox.

Folding coat hanger

In chromed brass.
With stainless steel spring.

| Articolo - Item | €/pc. | ↔ mm. | 📦 kg. |
|-----------------|-------|-------|-------|
| M 35 25 075 | | 75x25 | 0,300 |



Gancetto semplice Hook

In ottone cromato.

In chromed brass.

| Articolo - Item | €/pc. | €/box | ↔ mm. | 📦 kg. |
|-----------------|-------|-------|-------|-------|
| M 35 20 038 | | | 20x38 | 0,080 |



Fermaporta

In ottone cromato.

Door lock

In chromed brass.

| Articolo - Item | €/pc. | ↔ mm. | 📦 kg. |
|-----------------|-------|-------|-------|
| M 35 50 032 | | 50 | 0,060 |
| M 35 90 032 | | 76 | 0,080 |



Fermaporta magnetico orientabile

In ottone cromato.

Adjustable magnetic door lock

In chromed brass.

| Articolo - Item | €/pc. | 📦 kg. |
|-----------------|-------|-------|
| M 35 27 040 | | 0,200 |



Fermaporta

In ottone cromato.

Door lock

In chromed brass.

| Articolo - Item | €/pc. | 📦 kg. |
|-----------------|-------|-------|
| Z 43 00 165 | | 0,100 |



Chiusura a leva

In ottone cromato.

Toggle fastener

In chromed brass.

| Articolo - Item | €/pc. | 📦 kg. |
|-----------------|-------|-------|
| M 35 30 100 | | 0,090 |

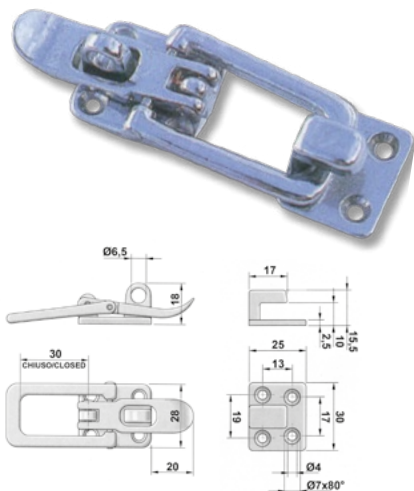

Fermaporta

In ottone cromato.

Door lock

In chromed brass.

| Articolo - Item | €/pc. | 📦 kg. |
|-----------------|-------|-------|
| M 35 25 060 | | 0,100 |

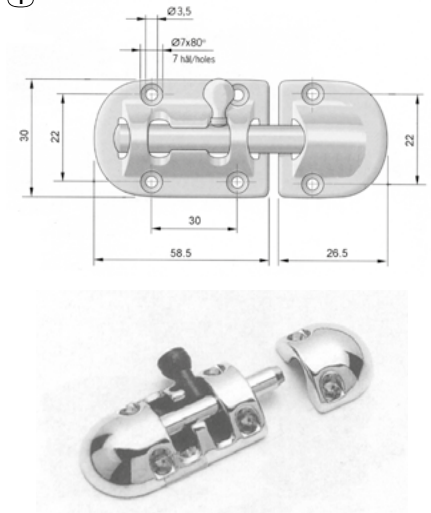

Chiusura a leva

In ottone.

Toggle fastener

In brass.

| Articolo - Item | €/pc. | 📦 kg. |
|-----------------|-------|-------|
| M 35 10 030 | | 0,130 |

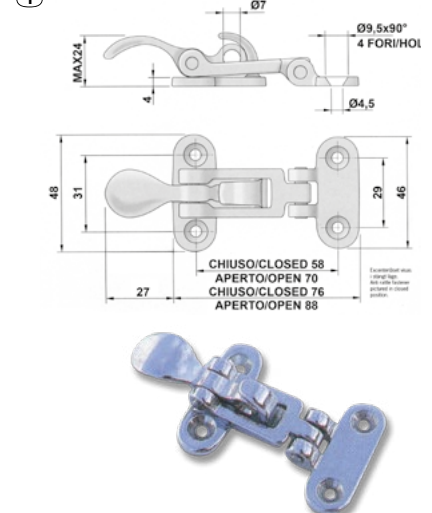

Serratura in nylon bianco per cassette con pulsante in ottone

White nylon door lock with brass knob

| Articolo - Item | €/pc. | kg. |
|-----------------|-------|-------|
| M 35 00 218 | | 0,100 |

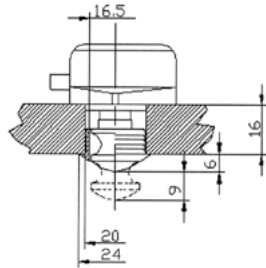

Scrocco in nylon

Nylon latch

| Articolo - Item | €/pc. | Mod. | kg. |
|-----------------|-------|-----------------------|-------|
| M 35 16 034 | | Con pomello-With knob | 0,100 |

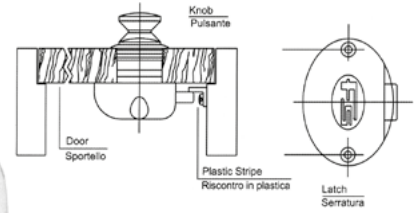

Serratura per portelli con pulsante in ottone lucido

Door lock with polished brass knob

| Articolo - Item | €/pc. | A mm. | B mm. | C mm. | kg. |
|-----------------|-------|-------|-------|-------|-------|
| M 35 19 243 | | 19 | 3,5 | Ø 35 | 0,150 |

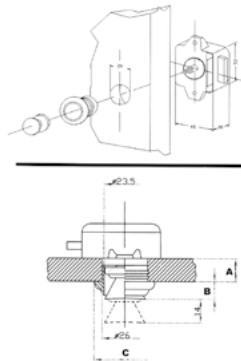

Pomello per portello

Fabbricato in plastica e ottone cromato.

Knob for door

Manufactured in plastic and chromed brass.

| Articolo - Item | €/pc. | Ø mm. | Foro-Hole Ø mm. | kg. |
|-----------------|-------|-------|-----------------|-------|
| M 35 50 095 | | 40 | 30 | 0,130 |



Chiusura a filo per boccaporto

Hatch lock concealed mounting

Fabbricato in ottone cromato con tavella regolabile.

Manufactured in chromed brass.

| Articolo - Item | €/pc. | Ø esterno outer Ø mm. | Incasso Recess Ø mm. | Mod. | kg. |
|-----------------|-------|-----------------------|----------------------|------------------------------|-------|
| M 35 01 202 | | 84 | 68 | Con serratura With door lock | 0,300 |



Alzapagliolo in ottone

Brass bottom board lifting device

| Articolo - Item | €/pc. | mm. | kg. |
|-----------------|-------|-------|-------|
| N 30 57 040 | | 57x40 | 0,200 |



Alzapagliolo in ottone

Brass bottom board lifting device

| Articolo - Item | €/pc. | mm. | kg. |
|-----------------|-------|-------|-------|
| N 30 50 060 | | 50x60 | 0,100 |



Serratura in ottone ideale per gavoni

Brass door lock for peaks

| Articolo - Item | €/pc. | A mm. | kg. |
|-----------------|-------|-------|-------|
| S 24 44 073 | | 30 | 0,100 |

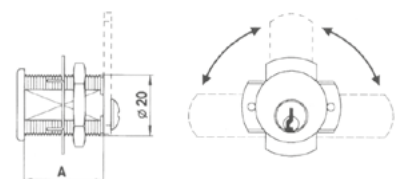
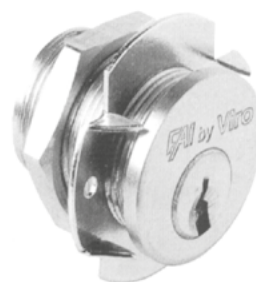

PORTACANNE | FISHING ROD HOLDERS

Interno per porta-canna inclinato a 45° Fishing rod holder inclined 45°

| Articolo - Item | €/pc. | A mm. | B mm. | C mm. | D mm. | E mm. | kg. |
|-----------------|-------|-------|-------|-------|-------|-------|-------|
| M 26 74 045 | | 220 | 100 | 42 | 60 | 50 | 0,140 |

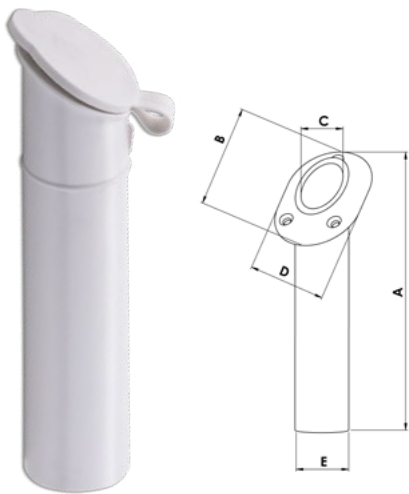

Portacanne a parete Wall mount fishing rod holder

| In PVC bianco. Kit 2 pz. | | In white PVC. Kit 2 pcs. | | | | |
|--------------------------|--------|--------------------------|-------|-------|-------|-------|
| Articolo - Item | €/pair | A mm. | B mm. | C mm. | Ø mm. | kg. |
| M 26 00 004 | | 73 | 380 | 19 | 42 | 0,480 |

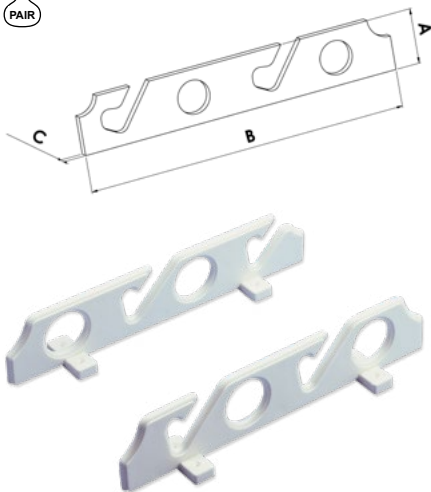

Portacanne a parete Wall mount fishing rod holder

| In PVC bianco. Kit 2 pz. | | In white PVC. Kit 2 pcs. | | | | |
|--------------------------|--------|--------------------------|-------|-------|-------|-------|
| Articolo - Item | €/pair | A mm. | B mm. | C mm. | Ø mm. | kg. |
| M 26 00 006 | | 73 | 560 | 19 | 42 | 0,630 |



Portacanna ad incasso in nylon, anti U.V. Nylon flush mount rod holder, U.V. resistant

| Articolo - Item | €/pc. | A mm. | B mm. | C mm. | D mm. | E mm. | kg. |
|-----------------|-------|-------|-------|-------|-------|-------|-------|
| M 26 40 240 | | 280 | 105 | 45 | 85 | 55 | 0,170 |



Portacanna per battagliola Fishing rod holder for guard-rail

| Fabbricato in plastica antiurto. Made of shockproof plastic. | | | | | | | |
|--|-------|-------|-------|-------|-------|-------|-------|
| Articolo - Item | €/pc. | A mm. | B mm. | C mm. | D mm. | E mm. | kg. |
| M 26 00 215 | | 30 | - | 42 | - | 50 | 0,250 |



Portacanna a parete Wall mount fishing rod holder

| In PVC bianco. | | In white PVC. | | | | | |
|-----------------|-------|---------------|-------|-------|-------|-------|-------|
| Articolo - Item | €/pc. | A mm. | B mm. | C mm. | D mm. | E mm. | kg. |
| M 26 40 001 | | 300 | - | 42 | - | 50 | 0,200 |

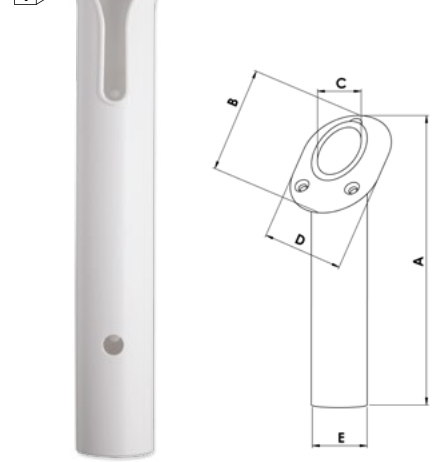

Portacanna a parete Wall mount fishing rod holder

| In PVC bianco. 2 posti. | | In white PVC. 2 places. | | | | |
|-------------------------|-------|-------------------------|-------|-------|---------------|-------|
| Articolo - Item | €/pc. | A mm. | B mm. | C mm. | Ø interno mm. | kg. |
| M 26 40 002 | | 270 | 300 | 65 | 42 | 0,250 |

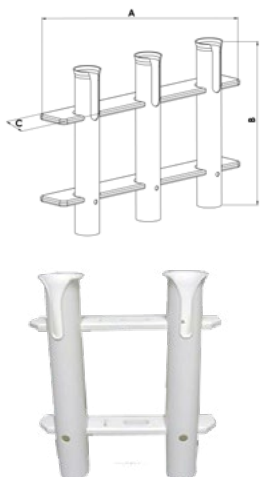

Portacanna a parete Wall mount fishing rod holder

| In PVC bianco. 3 posti. | | In white PVC. 3 places. | | | | |
|-------------------------|-------|-------------------------|-------|-------|---------------|-------|
| Articolo - Item | €/pc. | A mm. | B mm. | C mm. | Ø interno mm. | kg. |
| M 26 40 003 | | 440 | 300 | 65 | 42 | 0,350 |

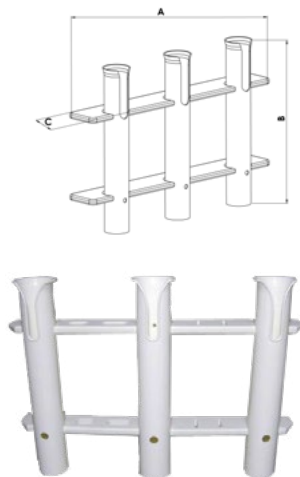

Portacanna a parete Wall mount fishing rod holder

| In PVC bianco. 4 posti. | | In white PVC. 4 places. | | | | |
|-------------------------|-------|-------------------------|-------|-------|---------------|-------|
| Articolo - Item | €/pc. | A mm. | B mm. | C mm. | Ø interno mm. | kg. |
| M 26 40 004 | | 610 | 300 | 65 | 42 | 0,790 |



Portacanna fissaggio su battagliola

In plastica nera, orientabile, foro Ø 40 mm. Fissaggio su tubo Ø 22/25 mm. Anello rotante con blocco della canna.

Fishing rod holder for guard-rail

Made of black plastic, adjustable. Hole Ø 40 mm. Suitable for pipe Ø 22/25 mm. Rod holder locking system.

| Articolo - Item | €/pc. | Colore-Colour |
|-----------------|-------|---------------|
| M 26 74 079 | | |
| M 26 80 079 | | |

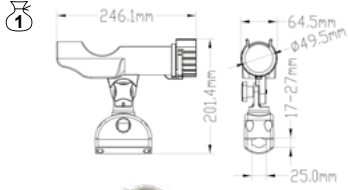

Portacanna fissaggio orizzontale

In plastica nera orientabile, foro Ø 40 mm. Fissaggio orizzontale con bassetta ad incasso. Anello rotante con blocco della canna.

Deck mount fishing rod holder

Made of black plastic, adjustable. Hole Ø 40 mm. Horizontal mounting. Rod holder locking system.

| Articolo - Item | €/pc. | Colore-Colour |
|-----------------|-------|---------------|
| M 26 74 179 | | |
| M 26 80 179 | | |

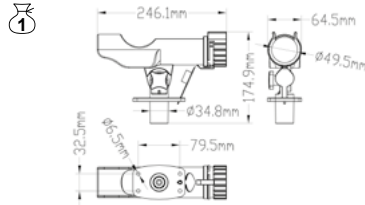

Portacanna inclinabile fissaggio su battagliola

Montaggio orizzontale-verticale. Plastica nera.

Fishing rod holder for guard-rail

Horizontal & vertical mounting. Black plastic.

| Articolo - Item | €/pc. | Attacco Fitting mm. | Ø interno inner Ø mm. |
|-----------------|-------|---------------------|-----------------------|
| M 26 44 250 | | Battagliola Ø 25 | 40 |



Portacanna fissaggio su battagliola

Può ruotare ed essere bloccato per 360°. Anello superiore di blocco della canna. Attacco su battagliola Ø 25 mm.

Fishing rod holder for guard-rail

360° adjustable. Rod holder locking system. Suitable for pipe Ø 25 mm.

| Articolo - Item | €/pc. | Colore Colour | Ø interno inner Ø mm. |
|-----------------|-------|---------------|-----------------------|
| M 26 23 540 | | | 40 |

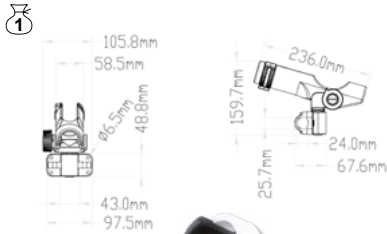

Portacanna regolabile con attacco sullo scalmò

Fabbricato in plastica nera.

Adjustable fishing rod holder for rowlock

Made of black colour plastic.

| Articolo - Item | €/pc. | Attacco Fitting | kg. |
|-----------------|-------|-----------------|---------|
| M 26 00 540 | | Scalmò-Rowlock | 1 0,440 |

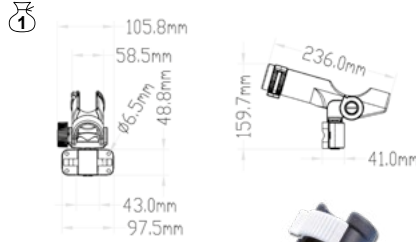

Portacanna attacco a parete

Rotazione orizzontale 360°, verticale 90°. Sistema di blocco della canna.

Wall mount fishing rod holder

Adjustable 360° horizontal, 90° vertical. Rod holder locking system.

| Articolo - Item | €/pc. | Ø interno inner Ø mm. |
|-----------------|-------|-----------------------|
| M 26 12 761 | | 40 |

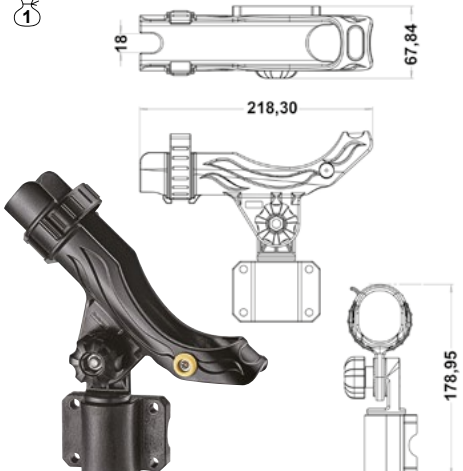

Portacanna attacco a parete

Rotazione orizzontale 360°, verticale 90°. Sistema di blocco della canna.

Wall mount fishing rod holder

Adjustable 360° horizontal, 90° vertical. Rod holder locking system.

| Articolo - Item | €/pc. | Ø interno inner Ø mm. |
|-----------------|-------|-----------------------|
| M 26 12 762 | | 50 |

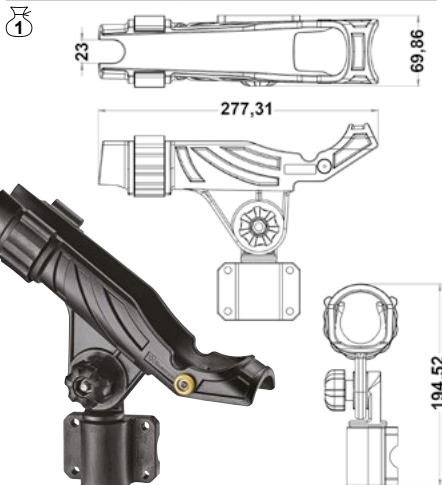

Portacanna attacco in piano

Rotazione orizzontale 360°, verticale 90°. Sistema di blocco della canna.

Deck mount fishing rod holder

Adjustable 360° horizontal, 90° vertical. Rod holder locking system.

| Articolo - Item | €/pc. | Ø interno inner Ø mm. |
|-----------------|-------|-----------------------|
| M 26 12 763 | | 40 |

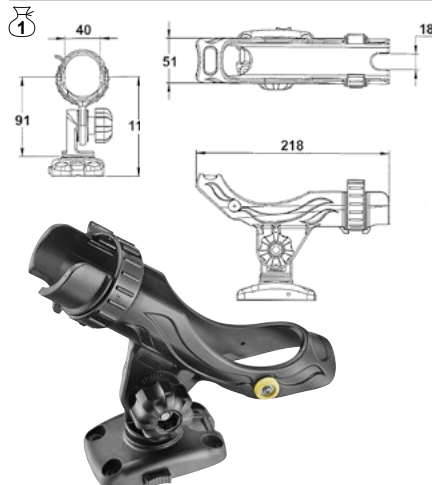

Portacanna attacco in piano

Rotazione orizzontale 360°, verticale 90°. Sistema di blocco della canna.

Deck mount fishing rod holder

Adjustable 360° horizontal, 90° vertical. Rod holder locking system.

| Articolo - Item | €/pc. | Ø interno inner Ø mm. |
|-----------------|-------|-----------------------|
| M 26 12 764 | | 50 |



AISI 316

Portacanna rimovibile

In acciaio inox Aisi 316.

Removable fishing rod holder

In Aisi 316 stainless steel.

| Articolo - Item | €/pc. | Foro-Hole Ø mm. | Length mm. | Base mm. | kg. |
|-----------------|-------|--------------------|---------------|-------------|-------|
| M 26 40 210 | | 40 | 210 | 100x75 | 0,310 |



AISI 316

Portacanna a parete

In acciaio inox Aisi 316.

Wall mount fishing rod holder

In Aisi 316 stainless steel.

| Articolo - Item | €/pc. | Foro-Hole Ø mm. | Length mm. | Mod. |
|-----------------|-------|--------------------|---------------|-------|
| M 26 42 250 | | 42 | 250 | Fixed |



NEW



AISI 316

Portacanna a parete 4 posti

In acciaio inox Aisi 316.

Wall mount fishing rod holder 4 places

In Aisi 316 stainless steel.

| Articolo - Item | €/pc. | Foro-Hole Ø mm. | Length mm. |
|-----------------|-------|--------------------|---------------|
| M 26 40 900 | | 40 | 900 |



NEW



AISI 316

Portacanna a parete

In acciaio inox Aisi 316.

Wall mount fishing rod holder

In Aisi 316 stainless steel.

| Articolo - Item | €/pc. | Foro-Hole Ø mm. | HxL mm. | Posti-Rod |
|-----------------|-------|--------------------|---------|-----------|
| M 26 45 003 | | 40 | 220x300 | 3 |
| M 26 45 004 | | 40 | 220x420 | 4 |



NEW



AISI 316

Portacanna attacco a scalmiera

In acciaio inox Aisi 316.

Rowlock fishing rod holder

In Aisi 316 stainless steel.

| Articolo - Item | €/pc. | Pole Ø mm. | Ø Canne Rod mm. | Posti Rod | Direction |
|-----------------|-------|---------------|--------------------|--------------|-----------|
| M 26 50 001 | | 32 | 50 | 1 | NORMAL |
| M 26 50 003 | | 32 | 50 | 3 | LEFT |
| M 26 50 103 | | 32 | 50 | 3 | RIGHT |



NEW



AISI 316

Portacanna con porta ami e porta coltello

In acciaio inox Aisi 316.

Rod holder with fishing hook holder and knife holder

In Aisi 316 stainless steel.

| Articolo - Item | €/pc. | Posti Rod | A mm. | B mm. | C mm. |
|-----------------|-------|--------------|----------|----------|----------|
| M 26 02 280 | | 2 | 280 | 240 | 76 |
| M 26 03 340 | | 3 | 340 | 240 | 76 |



NEW

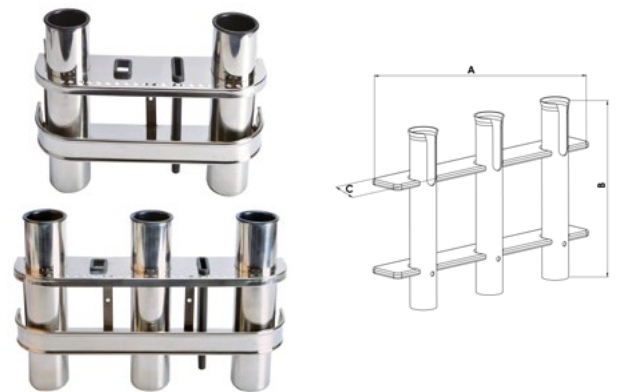

AISI 316

Portacanna ad inclinazione regolabile con attacco a pulpito, corrimano

In acciaio inox Aisi 316.
Fissaggio su tubo Ø 25 mm.

Fishing rod holder for guard-rail and pulpit multiposition adjustment

In Aisi 316 stainless steel.
Fixing on pipe Ø 25 mm.

| Articolo - Item | €/pc. | Foro-Hole Ø mm. | Length mm. | kg. |
|-----------------|-------|-----------------|------------|-------|
| M 26 80 272 | | 40 | 240 | 0,850 |



AISI 316

Portacanna con attacco a pulpito

In acciaio inox Aisi 316.
Fissaggio su tubo Ø 25 mm.

Fishing rod holder for pulpit

In Aisi 316 stainless steel.
Fixing on pipe Ø 25 mm.

| Articolo - Item | €/pc. | Foro-Hole Ø mm. | Length mm. | kg. |
|-----------------|-------|-----------------|------------|-------|
| M 26 42 020 | | 40 | 240 | 0,760 |



AISI 316

Portacanna con attacco a pulpito, corrimano

In acciaio inox Aisi 316.
Fissaggio su tubo Ø 35-40 mm.

Fishing rod holder for guard-rail and pulpit

In Aisi 316 stainless steel.
Fixing on pipe Ø 35-40 mm.

| Articolo - Item | €/pc. | Foro-Hole Ø mm. | Length mm. |
|-----------------|-------|-----------------|------------|
| M 26 40 220 | | 40 | 220 |



NEW



AISI 316

Portacanna con attacco a pulpito, corrimano

In acciaio inox Aisi 316.

Fishing rod holder for guard-rail and pulpit

In Aisi 316 stainless steel.

| Articolo - Item | €/pc. | A mm. | B mm. | C mm. | D mm. | kg. |
|-----------------|-------|-------|-------|-------|-------|-------|
| M 26 50 025 | | 355 | 70 | 25-30 | 50 | 1,130 |

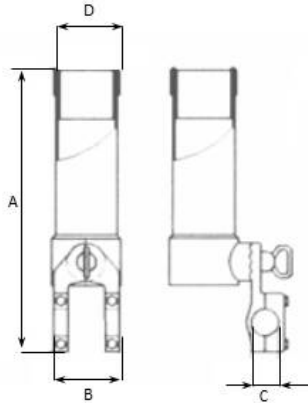

AISI 316

Portacanna con attacco a pulpito, corrimano

In acciaio inox Aisi 316.

Fishing rod holder for guard-rail and pulpit

In Aisi 316 stainless steel.

| Articolo - Item | €/pc. | A mm. | B mm. | C mm. | D mm. | E mm. | kg. |
|-----------------|-------|-------|-------|-------|-------|-------|-------|
| M 26 08 274 | | 230 | 35 | 42 | 22-25 | 30 | 0,800 |
| M 26 40 041 | | 230 | 35 | 42 | 25-32 | 40 | 0,690 |

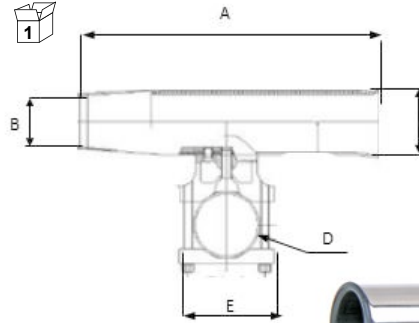

AISI 316

Portacanna inclinabile

In acciaio inox Aisi 316.

Adjustable deck mount rod holder

In Aisi 316 stainless steel.

| Articolo - Item | €/pc. | A mm. | B mm. | L mm. | D mm. | kg. |
|-----------------|-------|-------|-------|-------|-------|-------|
| M 26 50 095 | | 90 | 60 | 280 | 40 | 1,020 |

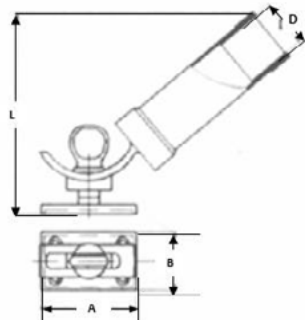
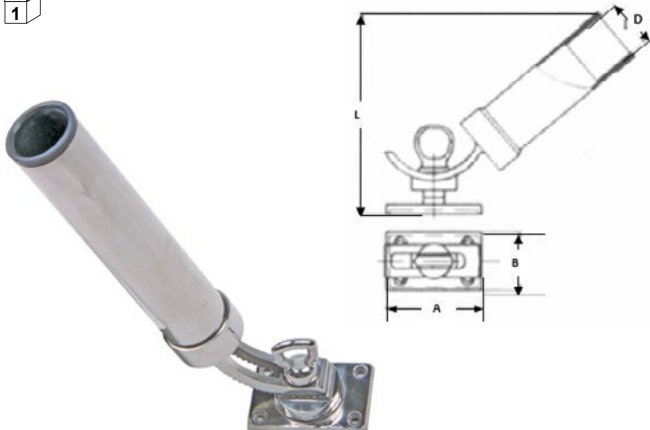

AISI 316

Portacanna da incasso

In acciaio inox Aisi 316.
Con flangia ovale completo di tappo.

Recessed mount fishing rod holder

In Aisi 316 stainless steel.
With oval flange and plug.

| Articolo - Item | €/pc. | Tappo Plug | Inclinazione Angle | A mm. | B mm. | C mm. | D mm. | E mm. | kg. |
|-----------------|-------|------------|--------------------|-------|-------|-------|-------|-------|-------|
| M 26 48 225 | | ■ | 15° | 230 | 107 | 41 | 91 | 51 | 0,260 |
| M 26 40 230 | | ■ | 45° | 230 | 107 | 41 | 91 | 51 | 0,500 |
| M 26 74 230 | | □ | 45° | 230 | 107 | 41 | 91 | 51 | 0,500 |

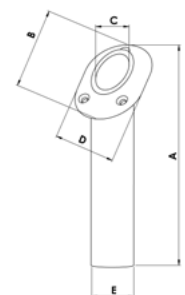
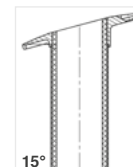
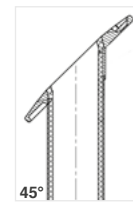

PORTACANNE | FISHING ROD HOLDERS

Portacanne ad inclinazione regolabile con fissaggio sulle battagliole o sui pulpiti

Fabbricato in ottone cromato.

Adjustable fishing rod holder for guard-rail and pulpit

Manufactured in chromed brass.

| Articolo - Item | €/pc. | A mm. | B mm. | C mm. | D mm. | kg. |
|-----------------|-------|-------|-------|----------|-------|-------|
| M 26 49 290 | | 300 | 65 | 22-25-30 | 40 | 1,200 |

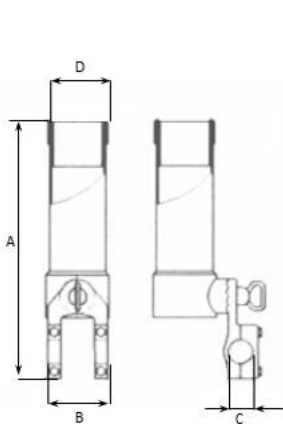

Portacanne ad inclinazione regolabile con base di fissaggio

Fabbricato in ottone cromato.
Completo di boccola in gomma.

Adjustable fishing rod holder with deck mount base

Manufactured in chromed brass.
With rubber bushing.

| Articolo - Item | €/pc. | A mm. | B mm. | L mm. | D mm. | kg. |
|-----------------|-------|-------|-------|-------|-------|-------|
| M 26 49 260 | | 100 | 65 | 200 | 40 | 1,050 |

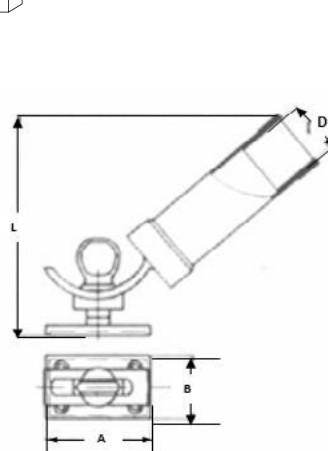

Portacanne per specchio di poppa

Fabbricato in ottone cromato, completo di morsetto.
Inclinabile e orientabile.

Fishing rod holder for transom

Manufactured in chromed brass.
With clamp.
Tilting and swiveling.

| Articolo - Item | €/pc. | Foro-Hole Ø mm. | kg. |
|-----------------|-------|-----------------|-------|
| M 26 50 000 | | 40 | 1,800 |



Portacanne ad inclinazione regolabile con base di fissaggio

Fabbricato in ottone cromato.
Completo di boccola in gomma.

Adjustable fishing rod holder with deck mount base

Manufactured in chromed brass.
With rubber bushing.

| Articolo - Item | €/pc. | A mm. | B mm. | L mm. | D mm. | kg. |
|-----------------|-------|-------|-------|-------|-------|-------|
| M 26 33 090 | | 100 | 65 | 200 | 33 | 0,850 |

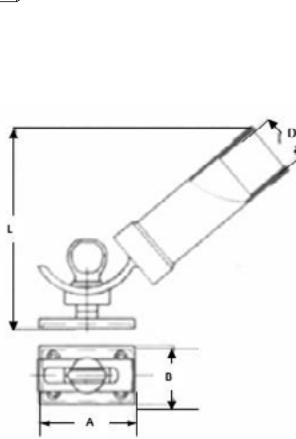

Portacanne con fissaggio sulle battagliole o sui pulpiti a morsetto

Fabbricato in ottone cromato.
Completo di boccola in gomma.
Lunghezza 230 mm.

Fishing rod holder for guard-rail and pulpit with clamp

Manufactured in chromed brass.
With rubber bushing.
Length 230 mm.

| Articolo - Item | €/pc. | Morsetto Clamp Ø mm. | Foro-Hole Ø mm. | kg. |
|-----------------|-------|----------------------|-----------------|-------|
| M 26 40 030 | | 20-30 | 40 | 1,000 |



Portacanne ad inclinazione regolabile con fissaggio a parete

Fabbricato in ottone cromato.
Completo di boccola in gomma.

Adjustable fishing rod holder deck mounting

Manufactured in chromed brass.
With rubber bushing.

| Articolo - Item | €/pc. | Base mm. | Foro-Hole Ø mm. | kg. |
|-----------------|-------|----------|-----------------|-------|
| M 26 00 290 | | 93x63 | 40 | 1,550 |



Sottovite in nylon con tappo

Tappo realizzato in materiali resistenti agli acetoni.

Nylon washer with cap

Cap manufactured in acetone resistant materials.

| Articolo - Item | €/box 60 kit | Foro-Hole Ø mm. | Colore Colour | kg. |
|-----------------|--------------|-----------------|---------------|-------|
| E 56 45 174 | | 4,5 | □ 9003 | 0,040 |
| E 56 55 174 | | 5,5 | □ 9003 | 0,060 |
| E 56 45 180 | | 4,5 | ■ | 0,040 |
| E 56 55 180 | | 5,5 | ■ | 0,060 |



Sottovite in nylon

Nylon washer

| Articolo - Item | €/box 100 pc. | Foro-Hole Ø mm. | Colore Colour | kg. |
|-----------------|---------------|-----------------|---------------|-------|
| E 56 45 074 | | 4,5 | □ 9003 | 0,040 |
| E 56 55 074 | | 5,5 | □ 9003 | 0,050 |
| E 56 45 080 | | 4,5 | ■ | 0,040 |

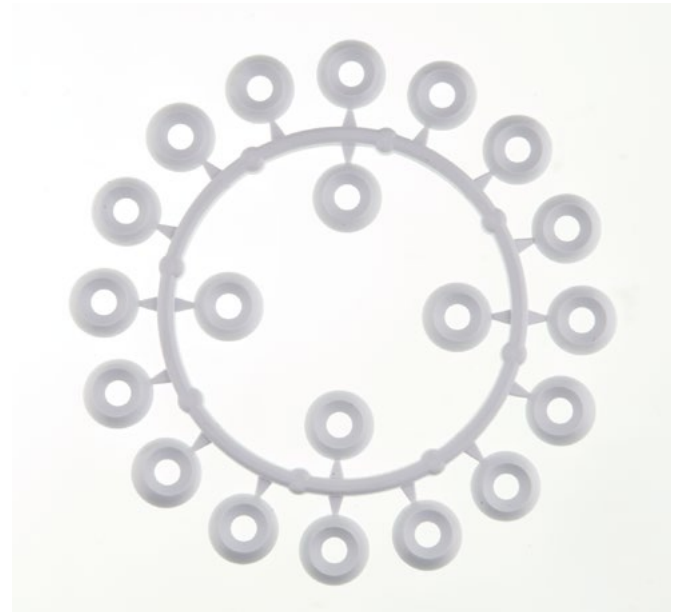

Distanziale per plexiglass

Fabbricati in nylon.

Spacer for windshield

Manufactured in nylon.

| Articolo - Item | €/box 40 kit | Foro-Hole Ø mm. | Colore Colour | Serie composta da: Set made of: | kg. |
|-----------------|--------------|-----------------|---------------|---------------------------------|-------|
| E 56 20 074 | | 4,5 | □ 9003 | MF-Distanziale Spacer | 0,330 |
| E 56 20 080 | | 5,5 | ■ | MF-Distanziale Spacer | 0,320 |



Cassetta attrezzi professionale

Valigia in materiale plastico antiurto. Utensili fabbricati in cromo vanadium.

Professional tool box

Tool box made of anti-shock plastic material. Tools made in chromo vanadium.

- Compo-sta da:**
- 20pcs punte per cacciavite
 - 1pc martello
 - 1pc cutter
 - 2pcs ø6x100 cacciaviti
 - 1pc 6" pinza a becco lungo
 - 4pcs cacciaviti di precisione
 - 5pcs chiavi esagonali
 - 1pc adattatore flessibile
 - 8pcs chiavi inglesi
 - 9pcs adattatori esagonali
 - 1pc pinza 6"
 - 1pc metro
 - 1pc livella
 - 1pc nastro isolante
 - 1pc cacciavite tester digitale
 - 1pc metro 3 metri

- Box includes:**
- 20pcs screwdriver bits
 - 1pc claw hammer
 - 1pc utility knife
 - 2pcs ø6x100 screwdrivers
 - 1pc 6" long nose plier
 - 4pcs precision screwdrivers
 - 5pcs hex wrenches
 - 1pc universal flexible shaft
 - 8pcs combination spanners
 - 9pcs sockets
 - 1pc 6" combination plier
 - 1pc extension rod
 - 1pc spirit level
 - 1pc insulating tape
 - 1pc digital test pencil
 - 1pc 3M measuring tape

| Articolo - Item | €/box | cm. | Utensili-Tools | kg. |
|-----------------|-------|---------|----------------|-------|
| D 10 42 033 | | 42x9x33 | 58 | 3,800 |



VITERIA | SCREWS

Vite autofilettante inox testa cilindrica a croce

S.S. self-threading cross cylindrical headed screw

| Articolo - Item | €/box | Ø mm. | Length mm. | pcs. |
|-----------------|-------|-------|------------|------|
| E 50 29 095 | | 2,9 | 9,5 | 25 |
| E 50 29 127 | | 2,9 | 12,70 | 25 |
| E 50 29 190 | | 2,9 | 19 | 20 |
| E 50 29 250 | | 2,9 | 25 | 20 |
| E 50 35 130 | | 3,5 | 13 | 20 |
| E 50 39 190 | | 3,9 | 19 | 20 |
| E 50 39 250 | | 3,9 | 25 | 15 |
| E 50 42 160 | | 4,2 | 16 | 15 |
| E 50 42 250 | | 4,2 | 25 | 15 |
| E 50 48 190 | | 4,8 | 19 | 10 |
| E 50 48 220 | | 4,8 | 22 | 10 |



Vite in acciaio inox testa cilindrica taglio a cacciavite

Cylindrical stainless steel screws head

| Articolo - Item | €/box | Ø mm. | Length mm. | pcs. |
|-----------------|-------|-------|------------|------|
| E 51 04 020 | | 4 | 20 | 6 |
| E 51 05 020 | | 5 | 20 | 5 |
| E 51 05 035 | | 5 | 35 | 5 |
| E 51 05 045 | | 5 | 45 | 5 |
| E 51 06 040 | | 6 | 40 | 3 |
| E 51 06 060 | | 6 | 60 | 2 |



Vite autofilettante inox testa svasata calotta a croce

S.S. self-threading cross countersink head w/cap

| Articolo - Item | €/box | Ø mm. | Length mm. | pcs. |
|-----------------|-------|-------|------------|------|
| E 50 29 013 | | 2,9 | 13 | 25 |
| E 50 29 019 | | 2,9 | 19 | 25 |
| E 50 35 013 | | 3,5 | 13 | 20 |
| E 50 35 016 | | 3,5 | 16 | 20 |
| E 50 39 019 | | 3,9 | 19 | 20 |
| E 50 39 025 | | 3,9 | 25 | 15 |
| E 50 42 016 | | 4,2 | 16 | 15 |
| E 50 42 019 | | 4,2 | 19 | 15 |
| E 50 42 025 | | 4,2 | 25 | 10 |
| E 50 42 032 | | 4,2 | 32 | 10 |
| E 50 48 025 | | 4,8 | 25 | 10 |
| E 50 48 032 | | 4,8 | 32 | 10 |
| E 50 48 045 | | 4,8 | 45 | 5 |



Vite inox testa svasata con calotta a taglio a cacciavite

Stainless steel self-screw countersink head with cap

| Articolo - Item | €/box | Ø mm. | Length mm. | pcs. |
|-----------------|-------|-------|------------|------|
| E 52 03 020 | | 3 | 20 | 5 |
| E 52 04 040 | | 4 | 40 | 3 |
| E 52 05 050 | | 5 | 50 | 2 |
| E 52 05 060 | | 5 | 60 | 2 |

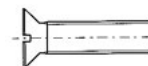

Vite autofilettante inox testa svasata piana a croce

Stainless steel self-threading cross countersink head

| Articolo - Item | €/box | Ø mm. | Length mm. | pcs. |
|-----------------|-------|-------|------------|------|
| E 51 29 130 | | 2,9 | 13 | 25 |
| E 51 29 190 | | 2,9 | 19 | 20 |
| E 51 29 250 | | 2,9 | 25 | 20 |
| E 51 35 130 | | 3,5 | 13 | 20 |
| E 51 35 160 | | 3,5 | 16 | 20 |
| E 51 39 160 | | 3,9 | 16 | 20 |
| E 51 39 250 | | 3,9 | 25 | 15 |
| E 51 39 320 | | 3,9 | 32 | 10 |
| E 51 48 250 | | 4,8 | 25 | 10 |
| E 51 48 320 | | 4,8 | 32 | 8 |
| E 51 48 380 | | 4,8 | 38 | 8 |



Vite in acciaio inox testa esagonale

Stainless steel screws hexagonal head

| Articolo - Item | €/box | Ø mm. | Length mm. | pcs. |
|-----------------|-------|-------|------------|------|
| E 53 05 030 | | 5 | 30 | 4 |
| E 53 05 035 | | 5 | 35 | 4 |
| E 53 05 040 | | 5 | 40 | 4 |
| E 53 05 050 | | 5 | 55 | 4 |
| E 53 06 020 | | 6 | 20 | 4 |
| E 53 06 035 | | 6 | 35 | 4 |
| E 53 06 040 | | 6 | 40 | 4 |
| E 53 06 050 | | 6 | 50 | 4 |
| E 53 06 060 | | 6 | 60 | 2 |



Vite in acciaio inox testa cava esagonale

Stainless steel screws hexagonal concave head

| Articolo - Item | €/box | Ø mm. | Length mm. | pcs. |
|-----------------|-------|-------|------------|------|
| E 58 05 010 | | 5 | 10 | 6 |
| E 58 05 035 | | 5 | 35 | 4 |

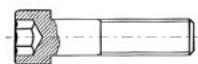

Dadi in acciaio inox autobloccanti

Self-locking nuts in stainless steel

| Articolo - Item | €/box | Ø mm. | pcs. |
|-----------------|-------|-------|------|
| E 59 04 000 | | 4 | 10 |
| E 59 05 000 | | 5 | 10 |
| E 59 06 000 | | 6 | 10 |
| E 59 08 000 | | 8 | 8 |
| E 59 10 000 | | 10 | 3 |



Galletti inox

Wing nuts in stainless steel

| Articolo - Item | €/box | Ø mm. | pcs. |
|-----------------|-------|-------|------|
| E 54 04 000 | | 4 | 3 |
| E 54 05 000 | | 5 | 3 |
| E 54 06 000 | | 6 | 3 |



Dadi esagonali medi in acciaio inox

Hexagonal jam nuts in stainless steel

| Articolo - Item | €/box | Ø mm. | pcs. |
|-----------------|-------|-------|------|
| E 57 04 000 | | 4 | 10 |
| E 57 05 000 | | 5 | 10 |
| E 57 06 000 | | 6 | 10 |
| E 57 08 000 | | 8 | 10 |
| E 57 10 000 | | 10 | 5 |



Rondelle UNI 6592 DIN 125

Washers in stainless steel UNI 6592 DIN 125

| Articolo - Item | €/box | Ø mm. | pcs. |
|-----------------|-------|-------|------|
| E 56 04 000 | | 4 | 40 |
| E 56 05 000 | | 5 | 40 |
| E 56 06 000 | | 6 | 30 |
| E 56 08 000 | | 8 | 20 |



Dadi ciechi in acciaio inox

Hex cap nuts in stainless steel

| Articolo - Item | €/box | Ø mm. | pcs. |
|-----------------|-------|-------|------|
| E 60 04 000 | | 4 | 4 |
| E 60 05 000 | | 5 | 4 |
| E 60 06 000 | | 6 | 4 |



Coppiglie inox

Stainless steel cotters

| Articolo - Item | €/box | Ø mm. | Length mm. | pcs. |
|-----------------|-------|-------|------------|------|
| E 54 15 025 | | 1,5 | 25 | 30 |
| E 54 02 035 | | 2 | 35 | 10 |
| E 54 03 040 | | 3 | 40 | 5 |

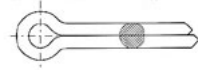

Rivetti in lega di alluminio

Aluminium alloy rivets

| Articolo - Item | €/box | Ø mm. | Length mm. | pcs. |
|-----------------|-------|-------|------------|------|
| E 55 28 018 | | 3,0 | 16 | 20 |
| E 55 38 016 | | 3,8 | 16 | 20 |
| E 55 48 014 | | 4,8 | 16 | 15 |
| E 55 48 020 | | 4,8 | 20 | 15 |



Rivetti in acciaio inox

Stainless steel rivets

| Articolo - Item | €/box | Ø mm. | Length mm. | pcs. |
|-----------------|-------|-------|------------|------|
| E 55 32 011 | | 3,2 | 11 | 10 |
| E 55 46 012 | | 4,9 | 12 | 10 |
| E 55 46 027 | | 4,9 | 27 | 10 |





SALVAGENTI ANULARI E ACCESSORI | RING LIFEBOUYS AND ACCESSORIES

Sistema di recupero uomo a mare «ARIETE LIGHT»

Conforme alla Direttiva Europea 89/686 EEC. Modello completo di custodia impermeabile munita di fibbie regolabili per l'applicazione al pulpito dell'imbarcazione. Il kit contiene 30 metri di cima Ø 8 mm.

«ARIETE LIGHT» man over-board rescue system

According to EN 89/686 EEC. Complete with waterproof bag and adjustable belts for pulpit fastening, including 30 m. floating rope Ø 8 mm. Breaking load 400 Kg.

| Articolo - Item | €/pc. | ↳ cm. | 📦 kg. |
|-----------------|-------|----------|-------|
| T 02 08 022 | | 40x22x12 | 1,250 |



4 strisce riflettenti omologate (adesivo)

In confezioni da 4 strisce da 40 cm., indicate per 1 salvagente anulare. Materiale omologato a norme Solas.

Retro-reflective R.I.N.A. homologated adhesive tape

Complies with Solas. Packing with 4 retro-reflective 40 cm. tapes suitable for 1 ring buoy.

| Articolo - Item | €/ kit da 4 strisce | Length cm. | H cm. | 📦 kg. |
|-----------------|---------------------|------------|-------|-------|
| E 34 05 004 | | 40 | 5 | 0,100 |

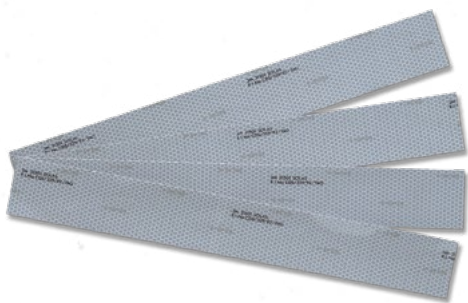

Baywatch Navy

Salvagente professionale. La superficie particolarmente liscia e la speciale conformazione facilitano il traino del salvagente fino alla persona da salvare. Completo di cima 2 mt. e tracolla.

Baywatch Navy

Professional lifeguard. Complete with 2 mt. rope and shoulder belt.

| Articolo - Item | €/pc. | ↳ cm. | 📦 kg. |
|-----------------|-------|-------|-------|
| T 02 02 309 | | 66x28 | 1,200 |



Nastro autoadesivo riflettente omologato R.I.N.A.

Da applicare a mezzi di salvataggio, atolli, salvagente, ecc. per naviglio da pesca e mercantile. Altezza 5 cm. Rotolo da 44 mt.

Retro-reflective R.I.N.A. homologated adhesive tape

Complies with Solas. Packing with 44 mt. retro-reflective tape suitable for ring buoys, etc. Height 5 cm.

| Articolo - Item | €/rotolo | 📏 mt. | H cm. | 📦 kg. |
|-----------------|----------|-------|-------|-------|
| E 34 05 044 | | 44 | 5 | 0,400 |

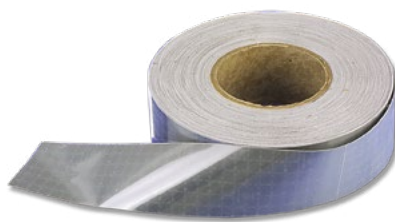

Kit sicurezza «POLARIS» completo di salvagente Ares, cima da 30 mt., boetta galleggiante

Custodia impermeabile completa di sistema di aggancio all'imbarcazione.

«POLARIS» safety kit complete with Ares lifebuoy, 30 mt. floating rope, lifebuoy light

Complete with waterproof bag and adjustable belts for pulpit fastening.

| Articolo - Item | €/kit | Galleggiabilità - Buoyancy kg. | 📦 kg. |
|-----------------|-------|--------------------------------|-------|
| N 16 60 004 | | 15 | 5,000 |



COMPOSTO DA KIT WITH



Art. T9008300 (pag. 96)



Art. N1575077 (pag. 97)



Art. L1990450S (pag. 109)

Salvagente anulare «ASTRA» omologato M.E.D. Dir. 2014/90

Con strisce riflettenti, struttura portante in materiale plastico indestruttibile ripieno di poliuretano espanso. Per nautica da diporto e marina mercantile.

«ASTRA» ring lifebuoy M.E.D. Dir. 2014/90 homologated

With 4 retro-reflective tapes. Manufactured in blow pressed polyethylene. Inside filled with expanded polyurethane. For leisure and merchant boating.

| Articolo - Item | €/pc. | Ø int. mm. | Ø est. mm. | kg. | Completo di-With |
|-----------------|-------|------------|------------|------|------------------|
| N 14 35 060 | | 40 | 65 | 2,50 | E3405004 |



SUGGESTED ITEM

(pag. 100)



Salvagente anulare «TAURUS» omologato M.E.D. Dir. 2014/90

Con strisce riflettenti, struttura portante in materiale plastico indestruttibile ripieno di poliuretano espanso. Per nautica da diporto e marina mercantile.

«TAURUS» ring lifebuoy M.E.D. Dir. 2014/90 homologated

With 4 retro-reflective tapes. Manufactured in blow pressed polyethylene. Inside filled with expanded polyurethane. For leisure and merchant boating.

| Articolo - Item | €/pc. | Ø int. mm. | Ø est. mm. | kg. | Completo di-With |
|-----------------|-------|------------|------------|------|------------------|
| N 14 75 045 | | 45 | 75 | 2,50 | E3405004 |
| N 14 04 075 | | 45 | 75 | 4,00 | E3405004 |



SUGGESTED ITEM

(pag. 100)



Salvagente anulare «ORCA»

Fabbricato in polistirolo a cellule chiuse, resistente agli idrocarburi. Rivestito in Pvc elettrosaldato.

«ORCA» ring lifebuoy

Covered by Pvc entirely welded. Inside in polystyrene resisting to oil. Complete with line.

| Articolo - Item | €/pc. | Colore fondo Colour | Colore fasce Bands colour | inner Ø cm. | outer Ø cm. | kg. |
|-----------------|-------|---------------------|---------------------------|-------------|-------------|-------|
| N 14 55 030 | | □ | ■ | 34 | 57 | 0,650 |
| N 14 55 075 | | □ | ■ | 34 | 57 | 0,650 |



SUGGESTED ITEM

(pag. 100)



Salvagente anulare «CORALLO»

Fabbricato in polistirolo a cellule chiuse, resistente agli idrocarburi. Rivestito in Pvc elettrosaldato.

«CORALLO» ring lifebuoy

Covered by Pvc entirely welded. Inside in polystyrene resisting to oil. Complete with line.

| Articolo - Item | €/pc. | Colore fondo Colour | Colore fasce Bands colour | inner Ø cm. | outer Ø cm. | kg. |
|-----------------|-------|---------------------|---------------------------|-------------|-------------|-------|
| N 14 65 040 | | □ | ■ | 40 | 65 | 0,850 |
| N 14 65 075 | | □ | ■ | 40 | 65 | 0,850 |



SUGGESTED ITEM

(pag. 100)

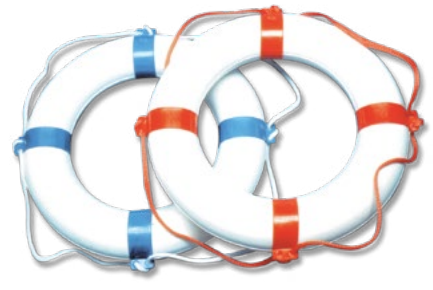

Salvagente anulare «PEGASO»

Fabbricato in polistirolo a cellule chiuse di tipo H, resistente agli idrocarburi.

«PEGASO» ring lifebuoy

Covered by Pvc entirely welded. Inside in polystyrene resisting to oil.

| Articolo - Item | €/pc. | Colore fondo Colour | Colore fasce Bands colour | inner Ø cm. | outer Ø cm. | kg. |
|-----------------|-------|---------------------|---------------------------|-------------|-------------|-------|
| N 14 60 035 | | □ | ■ | 35 | 60 | 0,800 |

Per un quantitativo minimo di 100 pz. è possibile la fornitura con il marchio del cliente. For a minimum quantity of 100 pcs. it is possible to print the trade-mark of the client.



SUGGESTED ITEM

(pag. 100)



Salvagente a ferro cavallo «ARES»

Fabbricato in espanso morbido, ricoperto di tessuto PVC e nylon, lavabile. Provvisto di corda a festoni e di moschettone in nylon a sganciamento rapido.

«ARES» horseshoe life buoy

Manufactured in soft foam, covered with Pvc and nylon. Washable.

| Articolo - Item | €/pc. | Colore fondo Colour | Galleggiabilità Buoyancy | kg. |
|-----------------|-------|---------------------|--------------------------|-------|
| N 15 15 077 | | ■ | 150N | 4,320 |



SUGGESTED ITEM

(pag. 100)



Salvagente a ferro cavallo «ORION»

Fabbricato in espanso morbido, ricoperto di tessuto PVC e nylon. Provvisto di una cerniera che rende facilmente sostituibile l'involucro esterno. Provvisto di cinghia e clips in nylon.

«ORION» horseshoe lifebuoy

Manufactured in soft foam, covered with Pvc and nylon. Washable. Supplied with hinge for an easy replacement of the outer covering. With belt and nylon clips.

| Articolo - Item | €/pc. | Colore fondo Colour | Galleggiabilità Buoyancy | kg. |
|-----------------|-------|---------------------|--------------------------|-------|
| N 15 75 077 | | ■ | 140N | 4,050 |



SUGGESTED ITEM

(pag. 100)



Salvagente a ferro cavallo

Fabbricato in espanso morbido, ricoperto di tessuto PVC e nylon. Provvisto di una cerniera che rende facilmente sostituibile l'involucro esterno.

Horseshoe lifebuoy

Manufactured in soft foam, covered with Pvc and nylon. Supplied with zipper for an easy replacement of the outer cover.

| Articolo - Item | €/pc. | Colore fondo Colour | Galleggiabilità Buoyancy | kg. |
|-----------------|-------|---------------------|--------------------------|-------|
| N 15 55 001 | | ■ | 140N | 4,000 |



SUGGESTED ITEM

(pag. 100)





Kit salvagente anulare «TAURUS» 2,5 kg. MED

Provvisto di cima di salvataggio Ø 8 mm. 30 m. e supporto.

«TAURUS» life guard kit ring buoy 2,5 kg. MED

With 30 m. Ø 8 mm. throwing rope.

| Articolo - Item | €/Kit. | Colore fondo Colour | Colore fasce Bands colour | Ø esterno outer Ø cm. | kg. |
|-----------------|--------|---------------------|---------------------------|-----------------------|-------|
| N 14 03 045 | | | | 75 | 4,200 |



COMPOSTO DA - KIT WITH

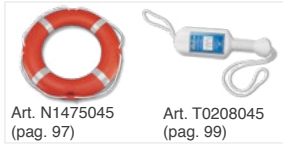

Art. N1475045 (pag. 97)

Art. T0208045 (pag. 99)

SUGGESTED ITEM



Art. N1725320 (pag. 100)



Ferro di cavallo «ARES» kit completo di supporto e boetta «VEGA»

«ARES» horseshoe lifebuoy kit equipped with approved floating lifebuoy «VEGA»

| Articolo - Item | €/Kit. | Colore - Colour | kg. |
|-----------------|--------|-----------------|-------|
| N 15 15 377 | | | 4,900 |



COMPOSTO DA KIT WITH



Art. N1700320 (pag. 100)

Art. N1515077 (pag. 97)

Art. L1990450S (pag. 109)



Contenitore per salvagente ferro di cavallo

In tessuto spalmato in poliuretano a doppio strato imbottito. Completo di cinghie regolabili per fissaggio al pulpito. Apertura con cerniera.

Carry bag for horseshoe lifebuoy

Made of padded double layer polyurethane coated fabric. Complete with adjustable belts for pulpit fastening. Zipper opening.

| Articolo - Item | Articolo - Item | €/pc. | Per ferro di cavallo For horseshoe lifebuoy |
|-----------------|-----------------|-------|---|
| N 15 74 000 | N 15 75 000 | | N1575077 |



SUGGESTED ITEM



Art. T9008300 (pag. 96)

Art. N1575077 (pag. 97)

Art. L1990450S (pag. 109)



Involucro per salvagente anulare «ASTRA»

In tessuto spalmato in poliuretano a doppio strato imbottito. Completo di cinghie regolabili per fissaggio al pulpito. Apertura con cerniera. Può contenere la boetta luminosa e la cima regolamentare e l'anulare.

Carry bag for lifebuoy «ASTRA»

Made of padded double layer polyurethane coated fabric. Complete with adjustable belts for pulpit fastening. Zipper opening. Can hold lifebuoy light, safety line and ring lifebuoy.

| Articolo - Item | €/pc. | Colore - Colour |
|-----------------|-------|-----------------|
| N 14 68 074 | | |
| N 14 68 075 | | |



SUGGESTED ITEM

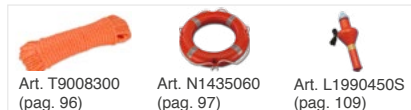

Art. T9008300 (pag. 96)

Art. N1435060 (pag. 97)

Art. L1990450S (pag. 109)



Involucro per salvagente anulare «TAURUS»

In tessuto spalmato in poliuretano a doppio strato imbottito. Completo di cinghie regolabili per fissaggio al pulpito. Apertura con cerniera. Può contenere la boetta luminosa e la cima regolamentare e l'anulare.

Carry bag for lifebuoy «TAURUS»

Made of padded double layer polyurethane coated fabric. Complete with adjustable belts for pulpit fastening. Zipper opening. Can hold lifebuoy light, safety line and ring lifebuoy.

| Articolo - Item | €/pc. | Colore - Colour |
|-----------------|-------|-----------------|
| N 14 25 074 | | |
| N 14 25 075 | | |



SUGGESTED ITEM

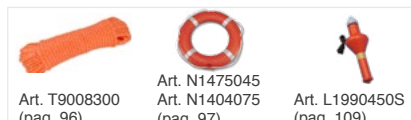

Art. T9008300 (pag. 96)

Art. N1475045 (pag. 97)
Art. N1404075 (pag. 97)

Art. L1990450S (pag. 109)

Cima galleggiante regolamentare «ECONOMY»

Per salvagente anulare, con moschettone in nylon. Treccia Ø 8 mm. Lunghezza 30 mt. Carico di rottura 400 kg.

Safety line floating rope «ECONOMY»

Complete with spliced nylon hook. Ø 8 mm. Length 30 mm. Breaking load 400 kg. Suitable for lifering.

| Articolo - Item | €/pc. 30 mt. | kg. |
|-----------------|--------------|-------|
| T 90 08 300 | | 0,600 |



SUGGESTED ITEM
(pag. 44)



Cima galleggiante regolamentare «PLUS»

Per salvagente anulare, con moschettone in nylon. Treccia Ø 8 mm. Lunghezza 30 mt. Carico di rottura 400 kg.

Safety line floating rope «PLUS»

Complete with nylon hook. Ø 8 mm. Length 30 mm. Breaking load 400 kg. Suitable for lifering.

| Articolo - Item | €/pc. 30 mt. | kg. |
|-----------------|--------------|-------|
| T 02 08 030 | | 0,600 |

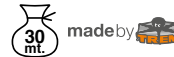

SUGGESTED ITEM
(pag. 44)



Bobina avvolgi cima per battagliola (priva di cima)

E' universale per tubi da 25 mm. Può contenere fino ad 80 metri di cima di Ø 8 mm.

Guard-rail reel for safety line (rope not included)

Suitable for pipes 25 mm. Can hold up to 80 mt. Ø 8 mm. rope.

| Articolo - Item | €/kit | mm. | kg. |
|-----------------|-------|---------|-------|
| B 50 18 300 | | 300x180 | 0,700 |



Cima da lancio 30 metri «ALBATROS»

Conforme alla convenzione Solas 74 e al D.M. 385 del 29/9/99 adatta sia per la Marina Mercantile che per la nautica da diporto. Kit completo di custodia rigida adatta per il fissaggio sui salvagenti anulari Ø int. 45 cm.

«ALBATROS» man overboard rescue rope 30 mt.

According to Solas 74 and D.M. 385 of 29/9/99 for Merchant Marine and leisure boating. Rope made of polypropylene Suitable for application on ring lifebuoys.

| Articolo - Item | €/kit | Modello completo di - Kit with | kg. |
|-----------------|-------|---------------------------------------|-------|
| T 02 08 045 | | 30 mt. cimapolipropilene-rope Ø 8 mm. | 1,150 |



Cima da lancio «SECURITY LINE» 23 metri

Ø 6 mm. Fabbricata in polietilene. Munito di maniglia alle estremità. Provvisto di attacchi.

«SECURITY LINE» 23 mt.

Ø 6 mm. Floating rope manufactured in polyethylene. Rope fitted with a side handle.

| Articolo - Item | €/kit | Modello completo di - Kit with | kg. |
|-----------------|-------|--------------------------------|-------|
| T 02 06 230 | | 23 mt. cima-rope Ø 6 mm. | 0,700 |



SUGGESTED ITEM

Art. T0200230
(pag. 100)



Cima da lancio «SECURITY ROPE» 30 metri

Ø 6 mm. Fabbricata in polietilene. Munito di maniglia alle estremità.

«SECURITY ROPE» 30 mt.

Ø 6 mm. Floating rope manufactured in polyethylene.

| Articolo - Item | €/kit | Modello completo di - Kit with | kg. |
|-----------------|-------|--------------------------------|-------|
| T 02 08 300 | | 30 mt. cima-rope Ø 6 mm. | 0,950 |



SUGGESTED ITEM

Art. T0200480
(pag. 100)



Arrotolatore per spiaggia

Fabbricato in acciaio inox. Privo di cima.

Rope reel for beach

Manufactured in stainless steel. Rope not included.

| Articolo - Item | €/pc. | Mod. | Pipe Ø mm. | kg. |
|-----------------|-------|---------------------|------------|-------|
| T 02 32 030 | | Arrotolatore - Reel | 25-30 | 5,600 |



SUGGESTED ITEM

Art. T1108300
(pag. 33)



AISI 316

Supporto per salvagente a ferro di cavallo e portaboetta **Holder for horseshoe lifebuoy with lifebuoy light holder**

| Articolo - Item | €/pc. | Length mm. | H mm. | Completo di attacco With holding clip |
|-----------------|-------|------------|-------|---------------------------------------|
| N 17 00 320 | | 510 | 360 | N1725000 |



COMPLETE WITH



SUGGESTED ITEM



AISI 316

Supporto per salvagenti anulari con portacima e portaboetta **Holder for ring lifebuoy with lifebuoy light holder and line holder**

| Articolo - Item | €/pc. | For mod. | Completo di attacco With holding clip | kg. |
|-----------------|-------|-----------------|---------------------------------------|-------|
| N 17 60 000 | | Astra Ø 65 cm. | N1725000 | 0,750 |
| N 17 75 000 | | Taurus Ø 75 cm. | N1725000 | 0,750 |



COMPLETE WITH



SUGGESTED ITEM



AISI 316

Contenitore per cima «SECURITY LINE» **Holder for «SECURITY LINE»**

| Articolo - Item | €/pc. | H mm. | Completo di attacco With holding clip | kg. |
|-----------------|-------|-------|---------------------------------------|-------|
| T 02 00 230 | | 305 | N1725000 | 0,400 |



COMPLETE WITH



SUGGESTED ITEM



AISI 316

Contenitore per cima «SECURITY ROPE» **Holder for «SECURITY ROPE»**

| Articolo Item | €/pc. | H mm. | Completo di attacco With holding clip | kg. |
|---------------|-------|----------|---------------------------------------|-------|
| T 02 00 480 | | 245xø120 | N1725000 | 0,250 |



COMPLETE WITH



SUGGESTED ITEM



AISI 316

Supporto per salvagenti a ferro di cavallo e anulari provvisto di supporto per boetta luminosa **Holder for horseshoe and ring lifebuoy with lifebuoy light holder**

| Articolo - Item | €/pc. | Pipes Ø mm. | Completo di attacco With holding clip | kg. |
|-----------------|-------|-------------|---------------------------------------|-------|
| N 17 25 520 | | 22-25 | N1725000 | 0,520 |



COMPLETE WITH



SUGGESTED ITEM



AISI 316

Supporto per salvagenti a ferro di cavallo e anulari **Holder for horseshoe and ring lifebuoy**

| Articolo - Item | €/pc. | Tubi-Pipes Ø mm. | Completo di attacco With holding clip |
|-----------------|-------|------------------|---------------------------------------|
| N 17 25 320 | | 22-25 | N1725000 |

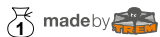

COMPLETE WITH



SUGGESTED ITEM



Kit morsetti Ø 25 per supporti

Completo di viteria.

| Articolo - Item | €/Kit | kg. |
|-----------------|-------|-------|
| N 17 25 000 | | 0,060 |



Holder clips for pipe Ø 25

Complete with screws.

Kit morsetti Ø 25~40 per supporti

Completo di viteria.

| Articolo - Item | €/Kit | kg. |
|-----------------|-------|-------|
| N 17 30 040 | | 0,080 |



Holder clips for pipe Ø 25~40

Complete with screws.

Giubbotto di salvataggio 100N «PAPUA» Life jacket 100N «PAPUA»

Il sistema di piegatura del collo riduce del 25% gli ingombri di stivaggio. Dotato di fibbia a sgancio rapido. UNI EN ISO 12402-4. Easy stowage. Including whistle and fast opening system. In compliance with UNI EN ISO 12402-4.

| Articolo - Item | €/pc. | Taglia-Size | Persona Person kg. | Circonferenza Circumference cm. | kg. |
|-----------------|-------|---------------|--------------------|---------------------------------|------|
| B 19 10 080 | | Ragazzo-Boy | 50-70 | 90-120 | 0,30 |
| B 19 10 103 | | Adulto-Adulte | >70 | 110-150 | 0,33 |



SUGGESTED ITEM



Giubbotto di salvataggio 150N «GUINEA» Life jacket 150N «GUINEA»

Il sistema di piegatura del collo riduce del 25% gli ingombri di stivaggio. Dotato di fibbia a sgancio rapido. UNI EN ISO 12402-3. Easy stowage. Including whistle and fast opening system. In compliance with UNI EN ISO 12402-3.

| Articolo - Item | €/pc. | Taglia-Size | Persona Person kg. | Circonferenza Circumference cm. | kg. |
|-----------------|-------|---------------|--------------------|---------------------------------|------|
| B 19 15 080 | | Ragazzo-Boy | 50-70 | 90-120 | 0,55 |
| B 19 15 103 | | Adulto-Adulte | >70 | 110-150 | 0,61 |



SUGGESTED ITEM



Borsa ideale per 4 giubbotti di salvataggio Bag suitable for 4 life jackets

In tessuto di nylon spalmato. Provvisto di cerna all'estremità. Made of nylon fabric, red colour, waterproof, with outside line.

| Articolo - Item | €/pc. | Mod. | cm. | Versione Version | kg. |
|-----------------|-------|---------------------|----------|------------------|-------|
| B 39 00 001 | | Fornito vuoto-Empty | 66x41x28 | Papua 100N | 1,200 |
| B 39 15 001 | | Fornito vuoto-Empty | 48x48x40 | Guinea 150N | 1,200 |



Salvante autogonfiabile da cintura 150N (ISO 12402-3) «AIR BAG»

Certificato AS1512. Si fissa alla vita creando un minimo ingombro. In caso di necessità lo si indossa in pochi secondi. Il gonfiaggio è con tirante manuale. Omologato.

Inflatable belt lifejacket 150N (ISO 12402-3) «AIR BAG»

AS1512 certified. You can quickly fix it to your waist with a minimum encumbrance. Manual activation.

| Articolo - Item | €/pc. |
|-----------------|-------|
| B 18 09 206 | |





Giubbotto di salvataggio/aiuto al galleggiamento 50N per vela

Life jacket 50N suitable for sailing boat

Sistema di regolazione composto da 4 nastri con fibbia a sgancio rapido provvisto di sottogamba.

closure with 4 belts and fast opening belt with underlegs.

UNI EN ISO 12402-5.

In compliance with UNI EN ISO 12402-5.

| Articolo - Item | €/pc. | Taglia-Size | Persona Person kg. | Circonferenza Circumference cm. |
|-----------------|-------|-------------|--------------------|---------------------------------|
| B 18 21 001 | | S | 25-40 | |
| B 18 21 002 | | M | 40-70 | 80-100 |



Giubbotto di salvataggio/aiuto al galleggiamento 50N per canoa

Life jacket 50N suitable for canoe

Sistema di regolazione composto da nastri con fibbia a sgancio rapido con elastico in vita. Provvisto di aggancio per cordicella di sicurezza e sottogamba UNI EN ISO 12402-5.

Fast opening belt closing system with underlegs In compliance with UNI EN ISO 12402-5.

| Articolo - Item | €/pc. | Taglia-Size | Persona Person kg. | Circonferenza Circumference cm. |
|-----------------|-------|-------------|--------------------|---------------------------------|
| B 18 20 003 | | L | 70-80 | 100-110 |



Giubbotto di salvataggio/aiuto al galleggiamento 50N per sci nautico o moto d'acqua

Life jacket 50N suitable for water ski

Sistema di regolazione composto da 3 cinghie con fibbie a sgancio rapido. Provvisto di aggancio per cordicella di sicurezza. UNI EN ISO 12402-5. provvisto di sottogamba.

Fast opening 3-belt closing system. In compliance with UNI EN ISO 12402-5. with underlegs

| Articolo - Item | €/pc. | Taglia-Size | Persona Person kg. | Circonferenza Circumference cm. |
|-----------------|-------|-------------|--------------------|---------------------------------|
| B 18 22 001 | | S | 25-40 | 65-80 |
| B 18 22 002 | | M | 40-70 | 80-100 |
| B 18 22 003 | | L | 70-80 | 100-110 |
| B 18 22 004 | | XL | 80+ | 110-125 |



Giubbotto di salvataggio gonfiabile 150N «SKIPPER»

«SKIPPER» inflatable life jacket 150N

Custodia in tessuto tecnologico ad alta resistenza. Accessori di serie: nastri retroriflettenti, fischietto, maniglia di sollevamento, nastro di recupero. Versione automatica. CE EN ISO 12402-3.

High-resistance bag. Supplied with retro-reflective tape, whistle, lifting handle, recovery tape. CE EN ISO 12402-3.

| Articolo - Item | €/pc. | Colore-Colour | Persona Person kg. | Circonferenza Circumference cm. |
|-----------------|-------|---------------|--------------------|---------------------------------|
| B 17 15 030 | | Red | 40+ | 80-125 |



Giubbotto di salvataggio 100N «ANTILLE» life jacket 100N «ANTILLE»

Sistema di regolazione composto da cerniera, nastro con fibbia a sgancio rapido, chiusura inferiore e sottogamba. Sistema di segnalazione composto da nastri riflettenti e fischietto.

Zipper closure and fast opening belt. Retro-reflective tape and whistle included. In compliance with UNI EN ISO 12402-4.

UNI EN ISO 12402-4.

| Articolo - Item | €/pc. | Taglia-Size | Persona Person kg. | Circonferenza Circumference cm. |
|------------------------|-------|-------------|--------------------|---------------------------------|
| B 19 30 001 | | XXS | 15-30 | 60-70 |
| B 19 40 001 | | XS | 30-40 | 70-80 |
| B 19 50 001 NEW | | S | 40-50 | 80-90 |
| B 19 70 001 NEW | | M | 50-70 | 90-100 |
| B 19 80 001 NEW | | L | 70-80 | 100-110 |
| B 19 90 001 NEW | | XL | 80-90 | 110-120 |
| B 19 95 001 NEW | | XXL | 90+ | 120-130 |



Giubbotto di salvataggio 150N «MARTINICA» life jacket 150N «MARTINICA»

Sistema di regolazione composto da cerniera, 2 nastri con fibbie a sgancio rapido, sottogamba regolabili. Sistema di segnalazione composto da nastri retroriflettenti e fischietto, maniglia di sollevamento, nastro di recupero.

Zipper closure and fast opening double-belt. Multi retro-reflective tape and whistle included. Lifting handle and recovery tape. In compliance with UNI EN ISO 12402-3.

UNI EN ISO 12402-3.

| Articolo - Item | €/pc. | Colore Colour | Taglia Size | Persona Person kg. | Circonferenza Circumference cm. |
|-----------------|-------|---------------|-------------|--------------------|---------------------------------|
| B 19 00 070 | | | XXS | 15-30 | 60-70 |
| B 19 00 080 | | | XS | 30-40 | 70-80 |
| B 19 00 090 | | | S | 40-50 | 80-90 |
| B 19 00 100 | | | M | 50-70 | 90-100 |
| B 19 00 110 | | | L | 70-80 | 100-110 |
| B 19 00 120 | | | XL | 80-90 | 110-120 |
| B 19 00 130 | | | XXL | 90+ | 120-130 |



Giubbotto di salvataggio 150N Life jacket 150N «MK10» a stola «MK10»

Pieghevole per ridurre gli spazi di stivaggio, costruito con materiale galleggiante a cellule chiuse, con fischietto e fasce riflettenti.

Easy stowage folding life jacket. Supplied with multi retro-reflective tape and whistle. SOLAS - M.E.D. ISO 12402-3.

| Articolo - Item | €/pc. | Altezza persona Height of user | Taglia Size | Persona Person kg. | Circonferenza Circumference cm. |
|-----------------|-------|--------------------------------|---------------|--------------------|---------------------------------|
| B 19 10 043 | | 100-155 | Ragazzo-Boy | 15-43 | |
| B 19 10 045 | | >155 | Adulto-Adulte | 43+ | max 175 |

Giubbotti omologati SOLAS M.E.D. Normativa MSC 200(80). Regolamentare per imbarcazioni da lavoro, pesca, passeggeri.



Giubbotto di salvataggio 150N Life jacket 150N «M-CUBE» a stola «M-CUBE»

Compatto e pieghevole, è il più piccolo al mondo. Fasce regolabili con fibbie a sgancio rapido, alloggio per clip luce, maniglie di sollevamento, Buddy System e porta badge. Istruzioni per essere indossato stampate tramite pittogrammi.

Easy stowage double-folding life jacket. Fast opening belt closing system. Supplied with multi retro-reflective tape and whistle. SOLAS - M.E.D.

| Articolo - Item | €/pc. | Altezza persona Height of user | Taglia Size | Persona Person kg. | Circonferenza Circumference cm. |
|-----------------|-------|--------------------------------|---------------|--------------------|---------------------------------|
| B 19 43 140 | | >155 | Adulto-Adulte | 43+ | max 175 |

Giubbotti omologati SOLAS M.E.D. Normativa MSC 200(80). Regolamentare per imbarcazioni da lavoro, pesca, passeggeri.





Bansigo per albero «SAILING»

Fabbricato in tessuto spalmato di PVC. Provvisto di fibbie di regolazione Aisi 316. Munito di rastrelliera porta-attrezzi, di tasca laterale, cinghie e nastri collaudati. Con tavoletta.

Bosun's chair «SAILING»

PVC coated cloth, with wrap-around back. Supplied with 2 pockets and a storage pocket. Adjusting belts in Aisi 316. With seat.

| Articolo - Item | €/pc. | cm. | kg. |
|-----------------|-------|---------------------------|-------|
| B 10 00 900 | | 44x43 - Seduta-Seat 40x20 | 1,200 |



Bansigo professionale senza tavoletta

Fabbricato in tessuto di nylon cordura, imbottito con espanso che fornisce un grande senso di sicurezza e allo stesso tempo libertà nei movimenti. Provvisto di tasca laterale, fibbie di regolazione e rastrelliera porta-attrezzi.

Bosun's chair without board

Manufactured in very thick nylon fabric, filled with expanded foam. It provides safety and at the same time gives freedom of movement. Supplied with side object-holder pocket and tool rack.

| Articolo - Item | €/pc. | cm. | kg. |
|-----------------|-------|-------|-------|
| B 10 45 910 | | 45x45 | 1,000 |



Bansigo professionale con tavoletta

Fabbricato in tessuto di nylon cordura, imbottito con espanso che fornisce un grande senso di sicurezza e allo stesso tempo libertà nei movimenti. Provvisto di tasca laterale, fibbie di regolazione e rastrelliera porta-attrezzi.

Bosun's chair with board

Manufactured in very thick nylon fabric, filled with expanded foam. It provides safety and at the same time gives freedom of movement. Supplied with side object-holder pocket and tool rack.

| Articolo - Item | €/pc. | cm. | kg. |
|-----------------|-------|-------|-------|
| B 10 40 910 | | 40x40 | 1,000 |



Bansigo per albero «A SEDILE»

Fabbricato in tessuto spalmato di PVC. Provvisto di tasca laterale, di fibbia di regolazione e rastrelliera porta-attrezzi. Con tavoletta.

Bosun's chair «A SEDILE»

PVC coated cloth, with wrap-around back. Supplied with 2 pockets and a storage pocket. With seat.

| Articolo - Item | €/pc. | cm. | kg. |
|-----------------|-------|-------|-------|
| B 10 00 890 | | 40x30 | 0,890 |



Bansigo per albero «AVVOLGENTE»

Fabbricato in tessuto spalmato di PVC. Provvisto di fibbie di regolazione Aisi 316. Munito di rastrelliera porta-attrezzi e di tasca laterale. Senza tavoletta.

Bosun's chair «AVVOLGENTE»

PVC coated cloth, with wrap-around back. Supplied with 2 pockets and a storage pocket. Adjusting belts in Aisi 316. Provided with a pocket to hold a tool box. Without wooden seat.

| Articolo - Item | €/pc. | cm. | kg. |
|-----------------|-------|-------|-------|
| B 10 00 920 | | 45x45 | 0,920 |



**Cintura di sicurezza «OLIMPIA»
Modello omologato 2016/425/
UE**

Spallacci fissi e regolazione in vita.
Fabbricata in cinghia di poliestere ad alta resistenza con ferramenta in acciaio inox a innesto rapido. Provvista di schienale e nastro riflettente.

Certificata a norme ISO 12401.

**Safety harness «OLIMPIA»
complying with rules
2016/425/UE**

Manufactured in high resistance polyester. Equipped with centre buckle, quick release system, stainless steel hardware. Adjustable waist-band and shoulder straps.

Complying with rules ISO 12401.

| Articolo - Item | €/pc. | Mod. | ↕ Torace Chest cm. | ↕ kg. | 📦 kg. |
|-----------------|-------|---------------|-----------------------|-------|-------|
| B 14 60 090 | | Ragazzo-Boy | 60-90 | 2000 | 0,400 |
| B 14 80 120 | | Adulto-Adulte | 80-120 | 2000 | 0,420 |



Cintura di sicurezza «Y.E.S.»

«Y Ergonomic Shape»

Disegno ergonomico massima vestibilità, provvista di regolazione sugli spallacci e in vita. Fabbricata in cinghia di poliestere e accessori in acciaio inox.

Adatta per persone di peso superiore a 50 kg.
Certificata a norme ISO 12401.

Safety harness «Y.E.S.»

«Y Ergonomic Shape»

Manufactured in high resistance polyester. Equipped with centre buckle, quick release system, stainless steel hardware. Adjustable waist-band and shoulder straps.

Suitable for people with weight > 50 kg.
Complying with rules ISO 12401.

| Articolo - Item | €/pc. | Mod. | ↕ Torace Chest cm. | ↕ kg. | 📦 kg. |
|-----------------|-------|---------------|-----------------------|-------|-------|
| B 14 20 000 | | Adulto-Adulte | 80-120 | 2000 | 0,750 |



Cintura di sicurezza «FORZA 7»

Spallacci fissi e regolazione in vita.
Fabbricata in cinghia di poliestere ad alta resistenza con ferramenta in acciaio inox a innesto rapido. Provvista di schienale e nastro riflettente.

Certificata a norme ISO 12401.

Safety harness «FORZA 7»

Manufactured in high resistance polyester. Equipped with centre buckle, quick release system, stainless steel hardware. Adjustable waist-band and shoulder straps.

Complying with rules ISO 12401.

| Articolo - Item | €/pc. | Mod. | ↕ Torace Chest cm. | ↕ kg. | 📦 kg. |
|-----------------|-------|---------------|-----------------------|-------|-------|
| B 14 20 062 | | Medium-Adulte | 80-120 | 2000 | 0,700 |



**Cintura di sicurezza «TANGO»
con gilet incorporato**

La cintura di sicurezza incorporata in un gilet facilita il modo di indossare la cintura stessa.

**Safety harness «TANGO»
with embedded lifejacket**

Equipped with centre buckle, quick release system, stainless steel hardware.

| Articolo - Item | €/pc. | Mod. | ↕ Torace Chest cm. | ↕ kg. | 📦 kg. |
|-----------------|-------|---------------|-----------------------|-------|-------|
| B 14 00 051 | | Adulto-Adulte | 80-120 | 2000 | 0,480 |



Cintura di sicurezza

Completa di cinghia di aggancio e due moschettoni

| Articolo - Item | €/pc. | Mod. | ↕ Torace Chest cm. | Taglia per persone Size for people | 📦 kg. |
|-----------------|-------|---------------|-----------------------|---------------------------------------|-------|
| B 15 90 130 | | Adulto-Adulte | 80-130 | >50 Kg. | 15-30 |



Safety harness

Complete with fastening life belt and two snap hooks

**Cintura di sicurezza adulto
«OCEANIC»**

Provvista di fibbia centrale a scatto in acciaio Aisi 316.

**Safety harness Adulte
«OCEANIC»**

With centre buckle, release type, made of Aisi 316 stainless steel.

| Articolo - Item | €/pc. | Mod. | ↕ Torace Chest cm. | ↕ kg. | 📦 kg. |
|-----------------|-------|---------------|-----------------------|-------|-------|
| B 14 20 200 | | Adulto-Adulte | 80-120 | 2000 | 0,500 |

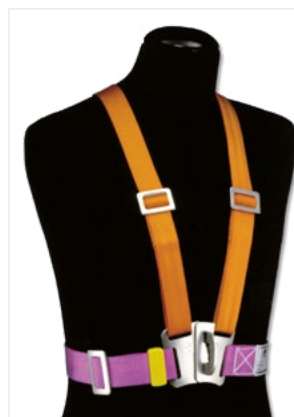

Cordone ombelicale

Per cinture di sicurezza modello CE.
Modello conforme alla direttiva.
Realizzate in cinghia di poliestere con
moschettone autobloccante CE Aisi 316.

Safety line

In compliance with CE directive.
Made of polyester belt with Aisi 316 self-locking
hook.

| Articolo - Item | €/pc. | Mod. | Descrizione Description | Moschettoni Snap hooks | Nastro Belt | kg. |
|--------------------|-------|------------|---------------------------------|---------------------------|----------------|------|
| B 14 02 200 | | | Statico <2 mt. | 1 | Singolo-Single | 2000 |
| B 14 20 002 | | HERCULES 1 | Statico <2 mt. | 2 | Singolo-Single | 2000 |
| B 14 02 077 | | MISTYK 2 | Elastico <2 mt. | 2 | Singolo-Single | 2000 |
| B 14 20 003 | | HERCULES 2 | Statico <2 mt. + Statico <1 mt. | 3 | Doppio-Double | 2000 |
| B 14 03 077 | | MISTYK 3 | Statico <1 mt. + Statico <2 mt. | 3 | Doppio-Double | 2000 |

Direttiva D.P.I. 2016/425/UE. Omologato ISO 12401.
Complying to Rule D.P.I. 2016/425/UE. ISO 12401.

SUGGESTED ITEM

Cinture - Safety harnesses
(pag. 105)



B 14 02 200



B 14 20 002



B 14 20 003



B 14 20 077

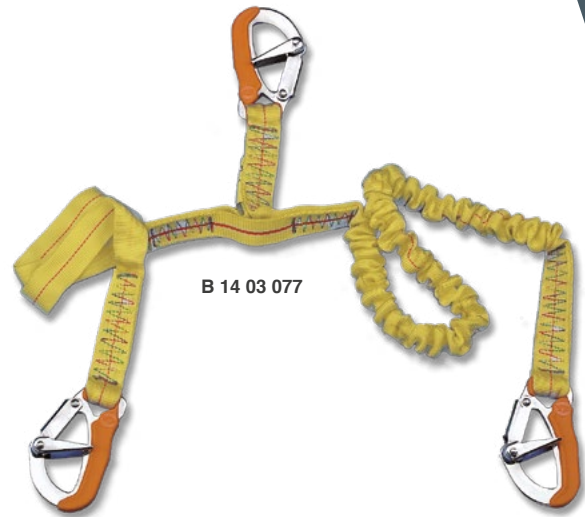

B 14 03 077

Cordone ombelicale «SEGURA»

Quando il cordone viene sottoposto a un carico eccessivo, l'indicatore di sovraccarico si scuote e lascia apparire un'etichetta che indica che il cordone deve essere sostituito. Moschettoni con doppia sicurezza.

Safety line «SEGURA»

Overload indicator included. Double-safety snap hooks.

| Articolo - Item | €/pc. | H mm. | Descrizione Description | Moschettoni Snap hooks | Nastro Belt | kg. |
|-----------------|-------|-------|--|------------------------|----------------|------|
| B 14 23 001 | 23 | | Statico 1,90 mt. | 1 | Singolo-Single | 2000 |
| B 14 23 002 | 23 | | Statico 1,90 mt. | 2 | Singolo-Single | 2000 |
| B 14 23 101 | 23 | | Elastico 1 mt.-Esteso 1,90 mt. | 1 | Singolo-Single | 2000 |
| B 14 23 102 | 23 | | Elastico 1 mt.-Esteso 1,90 mt. | 2 | Singolo-Single | 2000 |
| B 14 23 103 | 23 | | Statico 1 mt. + Elastico 1 mt. Esteso 1,90 mt. | 3 | Doppio-Double | 2000 |

NEW Direttiva D.P.I. 2016/425/UE. Omologato ISO 12401. Complying to Rule D.P.I. 2016/425/UE. ISO 12401.

SUGGESTED ITEM

Cinture - Safety harnesses (pag. 105)



SMART BAG

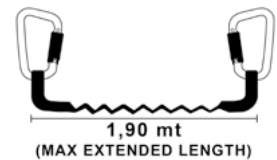
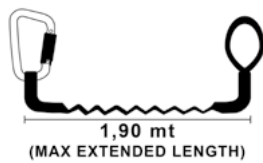

Cinghia di sicurezza in poliestere «LIFE LINE»

Polyester fastening belt «LIFE LINE»

| Articolo - Item | €/pc. | Length mt. | Colore Colour | ↑ kg. | ↓ kg. |
|-----------------|-------|------------|------------------|-------|-------|
| N 05 30 007 | | 7 | | 2000 | 0,425 |
| N 05 30 008 | | 8 | | 2000 | 0,450 |
| N 05 30 009 | | 9 | | 2000 | 0,475 |
| N 05 30 010 | | 10 | | 2000 | 0,500 |



Cinghia di aggancio provvista di un moschettone indicata per cinture di sicurezza

Munita di moschettone in acciaio inox, per garantire la movimentazione in sicurezza sull'imbarcazione durante la navigazione. Cinghia in poliestere.

Fastening belt for safety harness equipped with a snap hook

With a snap hook in stainless steel. Belt manufactured in polyester.

| Articolo - Item | €/pc. | Length cm. | ↑ kg. | ↓ kg. |
|-----------------|-------|------------|-------|-------|
| B 14 02 150 | | 200 | 2000 | 0,250 |



Cinghia di aggancio provvista di due moschettoni indicata per cinture di sicurezza

Munita di moschettoni in acciaio inox, per garantire la movimentazione in sicurezza sull'imbarcazione durante la navigazione.

Fastening belt for safety harness equipped with two snap hooks

With two snap hooks in stainless steel. Belt manufactured in polyester.

| Articolo - Item | €/pc. | H mm. | Length cm. | ↑ kg. | ↓ kg. |
|-----------------|-------|-------|------------|-------|-------|
| B 14 00 200 | | 30 | 200 | 2000 | 0,400 |



Cinghia di aggancio «HERCULES» provvista di tre moschettoni autobloccanti indicata per cinture di sicurezza

Munita di 3 moschettoni di sicurezza in acciaio inox, per rendere più sicuro lo spostamento da un punto di attacco all'altro durante la navigazione.

Fastening belt «HERCULES» for safety harness equipped with three self-locking snap hooks

With three self-locking snap hooks in stainless steel. Belt manufactured in polyester.

| Articolo - Item | €/pc. | Length cm. | ↑ kg. | ↓ kg. |
|-----------------|-------|------------|-------|-------|
| B 14 03 200 | | 100 + 100 | 2000 | 0,500 |



Cinghia elastica ombelicale per cinture di sicurezza provvista di due moschettoni inox

Lunghezza da 100 cm. a punto morto a 190 cm. in trazione. Fabricata con cinghia in nylon, tubolare e completa di elastico di recupero.

Elastic belt for safety harness with two snap hooks in stainless steel

Length: min. 100 - max. 190 cm. Retractable tubular safety belt. Belt manufactured in nylon.

| Articolo - Item | €/pc. | Length cm. | ↑ kg. | ↓ kg. |
|-----------------|-------|------------|-------|-------|
| B 14 00 205 | | 100-190 | 2000 | 0,400 |



Boetta luminosa galleggiante a Led «ISHTAR» a luce intermittente

Omologata Med. Fabbricata in materiale plastico antiurto. Alimentazione con 2 batterie da 1,5V. misura D.

Led floating lifebuoy light «ISHTAR» flashing light

Med approved. Manufactured in plastic anti-shock material. Powered by 2 alkaline 1,5 batteries D size.

| Articolo - Item | €/pc. | Mod. | ↑ cm. | 📦 pcs. | 📦 kg. |
|-----------------|-------|--|------------|--------|-------|
| L 19 90 070 | | Boetta Led MED MED Led lifebuoy light | 22H - Ø 12 | 1 | 0,190 |



SUGGESTED ITEM

Art. L1944035 (pag. 109)



Boetta luminosa a luce fissa «VEGA LED» omologata Med

Omologata Med. Luce bianca brillante a led con luminosità di 2 Candele. Alimentazione con 4 batterie alcaline da 1,5V. misura D.

Floating lifebuoy light «VEGA LED» steady light

Med approved. White and brilliant light with a capacity of 2 Candelas. Powered by 4 alkaline 1,5 batteries. D size.

| Articolo - Item | €/pc. | Mod. | 📦 pcs. | 📦 kg. |
|-----------------|-------|--|--------|-------|
| L 19 00 240 | | Boetta Vega MED Vega lifebuoy light MED | 1 | 0,240 |



SUGGESTED ITEM

Art. L1944035 (pag. 109)



COMPLETE WITH

Art. L4401006 (pag. 194)



Boetta luminosa a luce continua «VEGA SOLAS»

Fabbricata in materiale plastico antiurto. Luce bianca brillante con luminosità di 2 Candele. Alimentazione con 4 batterie alcaline da 1,5V. Misura D.

Floating lifebuoy light «VEGA SOLAS»

Manufactured in plastic anti-shock material. White and brilliant light with a capacity of 2 Candelas. Powered by 4 alkaline 1,5 batteries D size.

| Articolo - Item | €/pc. | Mod. | 📦 pcs. | 📦 kg. |
|-----------------|-------|------------------------------------|--------|-------|
| L 19 90 450 S | | Boetta Vega Vega lifebuoy light | 1 | 0,240 |



SUGGESTED ITEM

Art. L1944035 (pag. 109)



COMPLETE WITH

Art. L0716045 (pag. 193)



Boetta luminosa a luce intermittente Med provvista di supporto

Omologata Med. Voltaggio: 6V. Luminosità: superiore a 2 candele. Frequenza flash: 50/70 volte al minuto. Tempo di lavoro: superiore a 2 ore. Direttiva 96/98/EC.

Floating lifebuoy flashing light Med approved with holder

Med approved. Voltage: 6V. Light: > 2 candles. Flash frequency: 50/70 flashes/min. Working time: > 2h. According to Rule 96/98/EC.

| Articolo - Item | €/pc. | Mod. | Batterie-Batteries | 📦 kg. |
|-----------------|-------|--------------------|-----------------------------------|-------|
| L 19 00 072 | | Alogeno Halogen | 4 torce-torches (not included) | 0,470 |



Supporto per boette

Realizzato in plastica antiurto.

Lifebuoy light holder

Manufactured in shockproof plastic.

| Articolo - Item | €/pc. | Montaggio su tubo-Fitting on pipe Ø mm. |
|-----------------|-------|---|
| L 19 44 035 | | 25 |



Boetta luminosa al litio galleggiante

Omologata Med. Funzionamento con batterie al litio (include) Scadenza 5 anni. Supporto a parte.

Floating lifebuoy lithium light

Med approved. Lithium batteries (included) 5 years of operating life. Without bracket.

| Articolo - Item | €/pc. | Tipo-Type | 📦 kg. |
|-----------------|-------|-----------------|-------|
| L 19 20 500 | | Boetta-Light | 0,300 |
| L 19 00 500 | | Supporto-Holder | 0,060 |



DOTAZIONE SEGNALI 3NM

Dotazione segnali per la navigazione entro 3 miglia dalla costa

Confezione in busta impermeabile da:
 • 2 Fuochi a mano
 • 1 Boetta fumogena

Pleasure boating kit within 3 miles

Contents in a waterproof bag:
 • 2 Hand flares
 • 1 Smoke signal

| Articolo - Item | €/kit. | Tipo-Type | kg. |
|-----------------|--------|--------------------|-------|
| L 18 02 003 | | Approvato-Approved | 1,000 |

sul prezzo sopra indicato va aggiunto il contributo ambientale COGEPiR



DOTAZIONE SEGNALI 12NM

Dotazione segnali per la navigazione entro 12 miglia dalla costa

Confezione in contenitore da:
 • 2 Fuochi a mano
 • 2 Razzi a paracadute
 • 2 Boette fumogene

Pleasure boating kit within 6 and 12 miles

Contents:
 • 2 Hand flares
 • 2 Parachute signal rockets
 • 2 Smoke signals

| Articolo - Item | €/kit. | Tipo-Type | kg. |
|-----------------|--------|--------------------|-------|
| L 18 04 012 | | Approvato-Approved | 2,350 |

sul prezzo sopra indicato va aggiunto il contributo ambientale COGEPiR



DOTAZIONE SEGNALI 50NM

Dotazione segnali per la navigazione entro 50 miglia dalla costa

Confezione in contenitore da:
 • 3 Fuochi a mano
 • 3 Razzi a paracadute
 • 2 Boette fumogene

Pleasure boating kit within 50 miles

Contents:
 • 3 Hand flares
 • 3 Parachute signal rockets
 • 2 Smoke signals

| Articolo - Item | €/kit. | Tipo-Type | kg. |
|-----------------|--------|--------------------|-------|
| L 18 06 050 | | Approvato-Approved | 3,100 |

sul prezzo sopra indicato va aggiunto il contributo ambientale COGEPiR



DOTAZIONE SEGNALI NO LIMITS

Dotazione segnali per la navigazione oltre 50 miglia dalla costa (senza limiti)

Confezione in contenitore da:
 • 4 Fuochi a mano
 • 4 Razzi a paracadute
 • 3 Boette fumogene

Pleasure boating kit No limits

Contents:
 • 4 Hand flares
 • 4 Parachute signal rockets
 • 3 Smoke signals

| Articolo - Item | €/kit. | Tipo-Type | kg. |
|-----------------|--------|--------------------|-------|
| L 18 08 000 | | Approvato-Approved | 4,100 |

sul prezzo sopra indicato va aggiunto il contributo ambientale COGEPiR



FUOCO DI SEGNALAZIONE A MANO

Fuoco a mano a luce rossa

Hand flare red light

| Articolo - Item | €/pc. |
|-----------------|-------|
| L 18 00 300 | |

sul prezzo sopra indicato va aggiunto il contributo ambientale COGEPiR



RAZZO DI SEGNALAZIONE A PARACADUTE

Segnale razzo a paracadute

Parachute signal rocket

| Articolo - Item | €/pc. |
|-----------------|-------|
| L 18 00 390 | |

sul prezzo sopra indicato va aggiunto il contributo ambientale COGEPiR



BOETTA FUMOGENA

Boetta fumogena galleggiante

Floating smoke signal

| Articolo - Item | €/pc. |
|-----------------|-------|
| L 18 00 046 | |

sul prezzo sopra indicato va aggiunto il contributo ambientale COGEPiR



Cassetta pronto soccorso «Francia»

Cassetta pronto soccorso Nautikit in contenitore stagno ideale per imbarcazioni da diporto con equipaggio non formato da personale marittimo.

First aid kit «Francia»

Waterproof case. Suitable for leisure boating.

| Articolo - Item | €/pc. | Mod. |
|-----------------|-------|----------|
| D 13 10 320 | | >3 miles |
| D 13 10 321 | | <3 miles |



Sacca pronto soccorso Tabella D

Kit pronto soccorso in sacco stagno IP67. Contenuto come da tabella D fatta eccezione per alcuni medicinali che vanno acquistati separatamente in farmacia. Regolamento DL 01/10/2015 per naviglio: diporto senza limiti - pesca locale <12 miglia - pesca ravvicinata <20 miglia. Medicinali da acquistare: Clorexidina soluzione 5% flacone 1 Lt.

Soft bag first aid kit Tabella D

IP67 waterproof soft bag. Standard content according to Tabella D except Clorexidina 5% 1 Lt. In compliance with DL 01/10/2015.

| Articolo - Item | €/kit | mm. |
|-----------------|-------|--------------|
| D 13 43 464 S | | 470x366xH180 |



Cassetta pronto soccorso Tabella A

Cassetta pronto soccorso valigetta in contenitore stagno IP67. Contenuto come da tabella A fatta eccezione per alcuni medicinali che vanno acquistati separatamente in farmacia.

First aid kit Tabella A

IP67 waterproof hard box. Complete with waterproof gasket, pressure valve, soft handle, double-step safety closing system. Standard content according to Tabella D except Clorexidina 5% 1 Lt. Sodium Ipcolorito 1,15% - 1 Lt. Iodopovidone 10% - 3 Lt. In compliance with DL 01/10/2015.

Con guarnizione ermetica, valvola automatica di pressurizzazione, manico morbido, chiusura di sicurezza a doppio step, doppia predisposizione lucchetto e cerniera con perni in Nylon lungo tutto il profilo della valigia. Regolamento DL 01/10/2015 per naviglio: - diporto senza limiti con personale imbarcato o in attività di noleggio - pesca ravvicinata <40 miglia - passeggeri classe C <6 miglia - classe B <20 miglia - classe D <3 miglia. Medicinali da acquistare: Clorexidina soluzione 5% flacone - 1 Lt Ipcolorito di sodio soluzione 1,15% - 1 Lt Iodopovidone soluzione 10% per mucose e cute lesa - 3 Lt

Regolamentare DL 01/10/2015 per naviglio: - diporto senza limiti con personale imbarcato o in attività di noleggio - pesca ravvicinata <40 miglia - passeggeri classe C <6 miglia - classe B <20 miglia - classe D <3 miglia. Medicinali da acquistare: Clorexidina soluzione 5% flacone - 1 Lt Ipcolorito di sodio soluzione 1,15% - 1 Lt Iodopovidone soluzione 10% per mucose e cute lesa - 3 Lt

| Articolo - Item | €/pc. | mm. | Accessori-Accessories |
|-----------------|-------|--------------|-----------------------|
| D 13 50 555 | | 428x555xH211 | Cassetta-Box |
| D 13 00 001 | | - | Pulsossimetro |



Cassetta pronto soccorso

First Aid kit

Valigetta in contenitore stagno IP67. Waterproof IP67 hard case.

| Articolo - Item | €/pc. | mm. |
|-----------------|-------|------------|
| D 13 12 018 | | 130x180x70 |



Cassetta pronto soccorso

First Aid kit

Cassetta pronto soccorso Valigetta in contenitore stagno, con supporto a parete. Ideale per imbarcazioni da diporto con equipaggio non formato da personale marittimo. Vecchia Tabella D.

Waterproof hard case. Wall-mount holder included. Suitable for leisure boating.

| Articolo - Item | €/pc. | mm. |
|-----------------|-------|-------------|
| D 13 23 023 | | 310x250x130 |
| D 13 19 024 | | 320x240x90 |



Cassetta pronto soccorso Large

First Aid kit Large

Cassetta pronto soccorso Valigetta in contenitore stagno con supporto a parete. Ideale per imbarcazioni e navi da diporto con equipaggio formato anche parzialmente da personale marittimo. Vecchia Tabella A.

Waterproof hard case. Wall-mount holder included. Suitable for leisure boating.

| Articolo - Item | €/pc. | mm. |
|-----------------|-------|-------------|
| D 13 31 043 | | 310x430x150 |



ESTINTORI | FIRE EXTINGUISHERS

07

Estintore antincendio kg. 1 «Omologato MED-PED»

Modello funzionante con cartuccia di ABC sigillata. Modello ricaricabile. Provvisto di supporto per l'ancoraggio a parete.

| Articolo - Item | €/pc. | Classe | ↑ mm. | kg. |
|-----------------|-------|---------|--------------|-------|
| E 00 13 020 | | 34BC-5A | ø 83 x 300H. | 1,300 |



Fire extinguisher kg. 1 «MED-PED approved»

Provided with sealed ABC cartridge. Rechargeable model. Supplied with wall mounting bracket.

Estintore antincendio kg. 1 «Omologato MED-PED» completo di manometro

Modello funzionante con cartuccia di ABC sigillata. Modello ricaricabile. Provvisto di supporto per l'ancoraggio a parete.

| Articolo - Item | €/pc. | Classe | ↑ mm. | kg. |
|-----------------|-------|---------|--------------|-------|
| E 00 01 008 | | 8A-34BC | ø 83 x 300H. | 1,350 |



Fire extinguisher kg. 1 «MED-PED approved» with monometer

Provided with sealed ABC cartridge. Rechargeable model. Supplied with wall mounting bracket.

Estintore antincendio «Omologato MED-PED» completo di manometro

Estintore pressurizzato a polvere chimica, completo di carica e pronto per l'uso. Provvisto di supporto per l'ancoraggio a parete con fascetta fotoluminescente per una migliore individuazione dell'estintore al buio.

| Articolo - Item | €/pc. | Classe | ↑ mm. | Contenuto Content gr. | kg. |
|-----------------|-------|----------|---------------|-----------------------|-------|
| E 00 02 013 | | 13A-89BC | ø 110 x 390H. | 2000 | 2,650 |



Fire extinguisher «MED-PED approved» fitted with manometer

MED type-tested powder extinguishers with pressure gauge. Supplied with wall mounting bracket.

Anello antincendio

Fabbricato in plastica con membrana apribile a spinta in Pvc.

Fire ring

Manufactured in plastic material with Pvc membrane.

| Articolo - Item | €/pc. | ↑ mm. | kg. |
|-----------------|-------|-----------------------------------|-------|
| E 00 45 065 | | Ø est.-outer 70 - Ø int.-inner 45 | 0,020 |



SASSOLE E CONI TURAFALLE | BAILERS AND SAFETY PLUGS

Sassola mare «Extra freeze» 1 litro

Fabbricata in robusto materiale termoplastico. Resiste a -30°C, indicata per zattere di salvataggio. Capacità 1 litro.

| Articolo - Item | €/pc. | €/box | Colore Colour | Length mm. | kg. |
|-----------------|-------|-------|---------------|------------|-------|
| P 00 00 120 | | | | 200 | 0,750 |



Bailer «Extra freeze» 1 lt.

Made of strong thermoplastic material. Resistant at -30°C. Suitable for life rafts. Capacity 1 lt.

Sassola modello «Maxi» 2 litri

Fabbricata in robusto materiale termoplastico. Resiste a -30°C, indicata per zattere di salvataggio. Capacità 2 litri.

| Articolo - Item | €/pc. | Colore Colour | Length mm. | kg. |
|-----------------|-------|---------------|------------|-------|
| P 00 00 250 | | | 280 | 0,250 |



Bailer «Maxi» 2 lt.

Made of strong thermoplastic material. Resistant at -30°C. Suitable for life rafts. Capacity 2 lt.

Sassola modello «Imbuto con dosa olio»

Fabbricata in robusto materiale plastico. Indicata anche come dosa olio ed imbuto carburante. Con filtro. Capacità 1 litro.

| Articolo - Item | €/pc. | Colore Colour | Length mm. | kg. |
|-----------------|-------|---------------|------------|-------|
| P 00 00 130 | | | 280 | 0,130 |



Funnel bailer

Manufactured in plastic material. Suitable as oil and petrol dosing. With filter. Capacity 1 lt.

Serie 10 coni turafalle di emergenza

| Articolo - Item | €/Set 10 pcs. | Ø mm. | kg. |
|-----------------|---------------|-------|---------------|
| N 28 08 038 | | 8-38 | 10 coni 0,290 |



Serie 2 coni turafalle di emergenza

| Articolo - Item | €/Set 2 pcs. | Ø mm. | kg. |
|-----------------|--------------|-------|--------------|
| N 28 12 045 | | 12-45 | 2 coni 0,120 |



Fischietto «Ghibli» per giubbotti salvagente

Fabbricato in materiale plastico, colore rosso.

Plastic whistle «Ghibli» suitable for life jackets

Manufactured in plastic, red colour.

| Articolo - Item | €/pc. | €/box | Tipo - Type | kg. |
|-----------------|-------|-------|--------------------|-------|
| L 05 00 009 | | | Bitonale - Bitonal | 0,085 |



Avvisatore acustico Fog horn

Fabbricato in materiale plastico.

Manufactured in plastic.

| Articolo - Item | €/pc. | Ø mm | Length mm. | kg. |
|-----------------|-------|------|------------|-------|
| L 02 70 502 | | 70 | 200 | 0,150 |



Corno da nebbia Fog horn

Fabbricato in materiale plastico.

Manufactured in plastic.

| Articolo - Item | €/pc. | Length mm. | kg. |
|-----------------|-------|------------|-------|
| L 00 30 200 | | 320 | 0,100 |



Avvisatore acustico «Super sonor»

Completo di bomboletta a gas.

Acoustic horn «Super sonor»

With gas-canister.

| Articolo - Item | €/pc. | Mod. | Tipo - Type | ml. |
|-----------------|-------|--------------|--------------------------------|-----|
| L 02 00 480 | | GRANDE BIG | Eco Inflammabile Flammable | 250 |
| L 02 15 250 | | MEDIO MEDIUM | Non infiammabile Not flammable | 150 |



Bomboletta di ricambio per avvisatore «Super sonor»

Attacco con filetto universale a gas.

Spare gas canister for acoustic horn «Super sonor»

With universal thread.

| Articolo - Item | €/pc. | Mod. | Tipo - Type | ml. |
|-----------------|-------|--------------|--------------------------------|-----|
| L 03 00 400 | | GRANDE BIG | Eco Inflammabile Flammable | 250 |
| L 03 15 250 | | MEDIO MEDIUM | Non infiammabile Not flammable | 150 |



Avvisatore acustico Acoustic horn

Fabbricato in materiale plastico. Avvisatore acustico privo di bomboletta.

Manufactured in plastic. Without gas-canister.

| Articolo - Item | €/pc. | Mod. | kg. |
|-----------------|-------|------|-------|
| L 02 00 040 | | BIG | 0,040 |



Supporto per avvisatore acustico

Completo di viti in ottone per il fissaggio.

Bracket for acoustic horn

Complete with brass screws for fastening.

| Articolo - Item | €/pc. | kg. |
|-----------------|-------|-------|
| L 04 00 110 | | 0,030 |



Campana di bordo in ottone lucido

Completa di braccio e piastrina.

Nautical bells in polish brass

With bayonet bracket and striker.

| Articolo - Item | €/pc. | Ø mm. | H mm. | kg. |
|-----------------|-------|-------|-------|-------|
| L 01 00 450 | | 100 | 100 | 0,450 |
| L 01 00 500 | | 148 | 120 | 1,150 |
| L 01 00 800 | | 180 | 148 | 1,450 |



Campane omologate in ottone lucido

Obbligatorie per il diporto oltre 1 miglio dalla costa. Complete di braccio e piastrina. Omologate dal R.I.N.A. 27/12 del 1997, idonee per diporto e m.m.

Approved nautical polish brass bells

Compulsory device for leisure boating > 1 mile from coastline. With bayonet bracket and striker. Complying to R.I.N.A. 27/12 of 1997.

| Articolo - Item | €/pc. | Ø mm. | Per scafi For boats | kg. |
|-----------------|-------|-------|---------------------|-------|
| L 01 20 001 | | 210 | 12-20 mt. | 3,000 |



KIT DOTAZIONE DI SICUREZZA | KIT SAFETY

07

Borsa dotazione di sicurezza per 4 persone 100N

Costruita in nylon pesante spalmato in PVC all'interno per garantire l'impermeabilità, chiusura con zip in materiale plastico antisalino. Il kit contenuto nella borsa B0040070 contiene: 4 giubbotti salvagente B1910103 (100N UNI EN ISO 12402-4)
 +N1020015+T4808030+T0208030
 +P0000120+N2120300+L050009
 +E0013020+R0628000.

Safety bag 4 persons equipped with 100N lifejackets

Made of strong waterproof nylon, plastic zipper closing.

Including 4 lifejackets 100N UNI EN ISO 12402-4.
 +N1020015+T4808030+T0208030
 +P0000120+N2120300+L050009
 +E0013020+R0628000.

| Articolo - Item | €/pc. | mm. | Mod. | kg. |
|-----------------|-------|--------------|------------|-------|
| N 19 10 009 | | 450x360x360H | Piena-Full | 7,000 |

IN RIFERIMENTO ALLA NAVIGAZIONE SVOLTA I SEGNALI DI SOCCORSO (RAZZI DI SEGNALAZIONE) DEVONO ESSERE ORDINATI A PARTE
 DISTRESS SIGNALS SOLD SEPARATELY



Borsa dotazione di sicurezza per 4 persone 150N

Costruita in nylon pesante spalmato in PVC all'interno per garantire l'impermeabilità, chiusura con zip in materiale plastico antisalino. Il kit contenuto nella borsa B0015009 contiene: 4 giubbotti salvagente B1915103 (150N UNI EN ISO 12402-3)
 +N1020015+T4808030+T0208030
 +P0000120+N2120300+L050009
 +E0013020+R0628000.

Safety bag 4 persons equipped with 150N lifejackets

Made of strong waterproof nylon, plastic zipper closing.

Including 4 lifejackets 150N UNI EN ISO 12402-3.
 +N1020015+T4808030+T0208030
 +P0000120+N2120300+L050009
 +E0013020+R0628000.

| Articolo - Item | €/pc. | mm. | Mod. | kg. |
|-----------------|-------|--------------|------------|--------|
| N 19 15 009 | | 450x580x360H | Piena-Full | 10,250 |

IN RIFERIMENTO ALLA NAVIGAZIONE SVOLTA I SEGNALI DI SOCCORSO (RAZZI DI SEGNALAZIONE) DEVONO ESSERE ORDINATI A PARTE
 DISTRESS SIGNALS SOLD SEPARATELY



CONTENUTO DELLA BORSA DI DOTAZIONI | SAFETY BAG CONTENT

Ancora ombrello 1,5 kg.

In acciaio zincato.

| Articolo - Item | A pagina-On page |
|-----------------|------------------|
| N 10 20 015 | 48 |



Grapnel anchor 1,5 kg.

Made of galvanised steel.

Cima regolamentare per ancora

Completa di redancia in nylon, Ø 8 mm., lunghezza 30 mt.

| Articolo - Item | A pagina-On page |
|-----------------|------------------|
| T 48 08 030 | 28 |

made by



Anchor rope

Complete with nylon thimble, Ø 8 mm., length 30 mt.

Giubbotto di salvataggio

Dotato di fibbia a sgancio rapido.

| Articolo - Item | Mod. | A pagina-On page |
|-----------------|------|------------------|
| B 19 10 103 | 100N | 101 |
| B 19 15 103 | 150N | 101 |

made by



Life jacket

Including whistle and fast opening system.

Cima galleggiante regolamentare

Per salvagente anulare, con moschettone in nylon Ø 8 mm., lunghezza 30 mt.

| Articolo - Item | A pagina-On page |
|-----------------|------------------|
| T 02 08 030 | 96 |

made by



Floating safety rope

Ø 8 mm., length 30 mt. Complete with nylon hook.

Sassola piana

| Articolo - Item | A pagina-On page |
|-----------------|------------------|
| P 00 00 120 | 112 |

made by



Bailer

Bandiera Italiana Marina Mercantile

In tessuto poliestere.

| Articolo - Item | cm. | A pagina-On page |
|-----------------|-------|------------------|
| N 21 20 300 | 20x30 | 125 |

made by



Italian flag Merchant Shipping

Made of polyester.

Fischietto

| Articolo - Item | A pagina-On page |
|-----------------|------------------|
| L 05 00 009 | 113 |

made by



Whistle

Estintore in alluminio a polvere

Certificato.

| Articolo - Item | Kg. | A pagina-On page |
|-----------------|-----|------------------|
| E 00 13 020 | 1 | 112 |



Fire extinguisher

Certified.

Gancio d'accosto

| Articolo - Item | A pagina-On page |
|-----------------|------------------|
| R 06 28 000 | 527 |

made by



Boat hook

SICUREZZA | SAFETY

Borsa dotazione obbligatoria per navigazione da diporto entro 3 miglia

Il kit contiene:
 n. 4 giubbotti salvagente art. B1910103
 n. 1 cima per salvagente art. T0208030
 n. 1 Conf. segnali soccorso art. L1802003
 n. 1 tromba a gas TREM art. L0200480
 n. 1 estintore art. E0013020
 n. 1 bandiera italiana art. N2120300
 n. 1 cima per ancora art. T4808030
 n. 1 ancora 2,5 Kg art. N1020023
 n. 1 gancio accosto art. R0628000

Standard safety equipment bag for pleasure marine boats within 3 miles

Composition:
 n. 4 life jackets art. B1910103
 n. 1 safety line art. T0208030
 n. 1 distress signals art. L1802003
 n. 1 fog horn TREM art. L0200480
 n. 1 fire extinguisher art. E0013020
 n. 1 italian flag art. N2120300
 n. 1 anchor line art. T4808030
 n. 1 anchor 2,5 Kg art. N1020023
 n. 1 mooring hook art. R0628000

| Articolo - Item | €/pc. | Mod. | kg. |
|-----------------|-------|--------------------|-------|
| N 19 03 100 | | 3 miglia - 3 miles | 8,850 |



sul prezzo sopra indicato va aggiunto il contributo ambientale COGEPiR



Borsa dotazione obbligatoria per navigazione da diporto entro 6 miglia

Il kit contiene:
 n. 4 giubbotti salvagente art. B1910103
 n. 1 cima per salvagente art. T0208030
 n. 1 Conf. segnali soccorso art. L1804012
 n. 1 tromba a gas TREM art. L0200480
 n. 1 estintore art. E0013020
 n. 1 bandiera italiana art. N2120300
 n. 1 cima per ancora art. T4808030
 n. 1 ancora 2,5 Kg art. N1020023
 n. 1 gancio accosto art. R0628000

Standard safety equipment bag for pleasure marine boats within 6 miles

Composition:
 n. 4 life jackets art. B1910103
 n. 1 safety line art. T0208030
 n. 1 distress signals art. L1804012
 n. 1 fog horn TREM art. L0200480
 n. 1 fire extinguisher art. E0013020
 n. 1 italian flag art. N2120300
 n. 1 anchor line art. T4808030
 n. 1 anchor 2,5 Kg art. N1020023
 n. 1 mooring hook art. R0628000

| Articolo - Item | €/pc. | Mod. | kg. |
|-----------------|-------|--------------------|--------|
| N 19 06 100 | | 6 miglia - 6 miles | 10,250 |



sul prezzo sopra indicato va aggiunto il contributo ambientale COGEPiR



Borsa dotazione obbligatoria per navigazione da diporto entro 12 miglia

Il kit contiene:
 n. 4 giubbotti salvagente art. B1915103
 n. 1 cima per salvagente art. T0208030
 n. 1 Conf. segnali soccorso art. L1804012
 n. 1 tromba a gas TREM art. L0200480
 n. 1 estintore art. E0013020
 n. 1 bandiera italiana art. N2120300
 n. 1 cima per ancora art. T4808030
 n. 1 ancora 2,5 Kg art. N1020023
 n. 1 gancio accosto art. R0628000

Standard safety equipment bag for pleasure marine boats within 12 miles

Composition:
 n. 4 life jackets art. B1915103
 n. 1 safety line art. T0208030
 n. 1 distress signals art. L1804012
 n. 1 fog horn TREM art. L0200480
 n. 1 fire extinguisher art. E0013020
 n. 1 italian flag art. N2120300
 n. 1 anchor line art. T4808030
 n. 1 anchor 2,5 Kg art. N1020023
 n. 1 mooring hook art. R0628000

| Articolo - Item | €/pc. | Mod. | kg. |
|-----------------|-------|----------------------|--------|
| N 19 12 150 | | 12 miglia - 12 miles | 11,200 |



sul prezzo sopra indicato va aggiunto il contributo ambientale COGEPiR



Borse vuote per dotazione obbligatoria

Empty bags for safety equipment

| Articolo - Item | €/pc. | Colore - Colour | Giubbino - Jacket | kg. |
|-----------------|-------|-----------------|-------------------|-------|
| B 00 40 070 | | | 100N | 0,600 |
| B 00 15 009 | | | 150N | 0,600 |



Nota: per quantità di almeno 30 borse è possibile stampare il marchio del cliente.
Note: for a quantity over 30 pcs. it is possible to print the trade-mark of the customer.



ZATTERE | LIFERAFTS

07

Zattera di salvataggio Coastal Eurovinil

Zattera autogonfiabile costiera per navigazione da diporto entro le 12 miglia dalla costa. Il contenitore può essere morbido in valigia oppure rigido in contenitore di vetroresina.

Liferaft Coastal Eurovinil

Coastal liferaft within 12 miles from coastline. Soft case (available on demand with hard case).

| Articolo - Item | €/pc. | Persone-Seats | mm. | Container | kg. |
|-----------------|-------|---------------|-------------|-------------|-------|
| B 98 06 001 | | 6 | 660x360x170 | Valigia-Bag | 28,00 |
| B 98 08 001 | | 8 | 660x360x220 | Valigia-Bag | 33,00 |
| B 98 10 001 | | 10 | 660x490x200 | Valigia-Bag | 37,00 |
| B 98 12 001 | | 12 | 660x490x250 | Valigia-Bag | 42,00 |



Zattera di salvataggio Oceanic Eurovinil

Zattera autogonfiabile ISO 9650 Oceanic Italia per navigazione da diporto oltre le 12 miglia dalla costa. Il contenitore può essere morbido in valigia oppure rigido in contenitore di vetroresina.

Liferaft Oceanic Eurovinil

ISO 9650 Oceanic liferaft over 12 miles from coastline. Soft or hard case available.

| Articolo - Item | €/pc. | Persone-Seats | mm. | Container | kg. |
|-----------------|-------|---------------|-------------|---------------|-------|
| B 84 06 001 | | 6 | 695x500x300 | Valigia-Bag | 53,00 |
| B 84 06 002 | | 6 | 710x490x290 | Container VTR | 56,00 |
| B 84 08 001 | | 8 | 790x500x300 | Valigia-Bag | 65,00 |
| B 84 08 002 | | 8 | 800x500x310 | Container VTR | 68,00 |
| B 84 10 001 | | 10 | 790x500x310 | Valigia-Bag | 75,00 |
| B 84 10 002 | | 10 | 810x500x310 | Container VTR | 78,00 |



SICUREZZA | SAFETY

PORTA ZATTERA | CRADLES FOR LIFERAFTS

AISI 316

Kit fissaggio porta zattere Aisi 316

Completo di viteria.

Fixing kit for liferafts Aisi 316

Supplied with screws.

| Articolo - Item | €/kit |
|-----------------|-------|
| S 47 34 072 I | |



Culle porta zattera complete di cinghie

Modello estremamente versatile di colore bianco. Possibilità di applicazione sia in posizione orizzontale che verticale.

Plastic liferafts holder

Complete with belt with fastening buckle. Horizontal or vertical fitting.

| Articolo - Item | €/kit | Mod. |
|-----------------|-------|-----------|
| D 10 00 042 | | Universal |



AISI 316

Porta zattera a montaggio verticale tubo ø 30 mm.

Completo di attacchi in plastica.
Privo di antifurto.

Liferaft cradle vertical mounting pipe ø 30 mm.

Complete with plastic clamps.
Without antitheft device

| Articolo - Item | €/kit | H cm. | Width cm. | Length cm. | kg. |
|-----------------|-------|--------|-----------|------------|-------|
| S 47 34 070 | | 70-100 | 44-68 | 30-40 | 3,700 |

Montaggio pulpito piano-parete - Wall or pushpit vertical mounting



**ATTACCHI IN PLASTICA
PLASTIC CLAMPS**



SUGGESTED ITEM

Art. N0200030
(pag. 520)



AISI 316

Porta zattera in acciaio inox Aisi 316 per sgancio idrostatico

Fabbricato in tubo di acciaio inox ø 30 mm.
Completo di moschettone a sgancio rapido.
Predisposto per attacco idrostatico.
Fornito privo di attacchi, fissaggio tramite fori predisposti sul tubo.

Liferaft cradle Aisi 316 stainless steel for hydrostatic release system

Made of stainless steel pipe ø 30 mm.
Complete with pelican hook quick release.
Without antitheft device.

| Articolo - Item | €/kit | H cm. | Width cm. | Length cm. | kg. |
|-----------------|-------|-------|-----------|------------|-----|
| S 47 21 066 I | | 20-40 | 48-66 | 72-87 | |

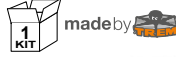

**MONTAGGIO PIANO
DECK MOUNTING**



SUGGESTED ITEM

Art. S4734072I
(pag. 116)



AISI 316

Telaio regolabile porta zattera in acciaio inox Aisi 316 tubo ø 30mm.

Fabbricato in tubo di acciaio inox.
Privo di antifurto.

Adjustable liferaft cradle Aisi 316 stainless steel pipe ø 30mm.

Pipe in stainless steel.
Without antitheft device.

| Articolo - Item | €/kit | H cm. | Width cm. | Length cm. |
|-----------------|-------|-------|-----------|------------|
| S 47 21 075 I | | 20-40 | 40-54 | 72-87 |

Montaggio pulpito piano-parete - Vertical, horizontal or pushpit mounting



COMPLETE WITH

Art. S4734072I
(pag. 116)

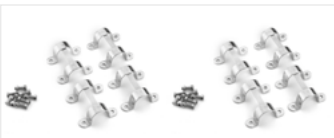

SUGGESTED ITEM

Art. N0200030
(pag. 520)

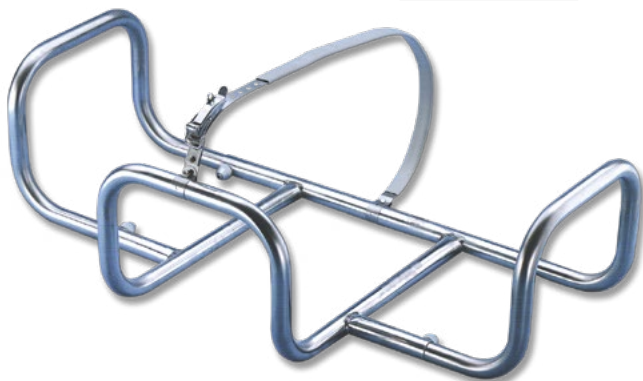

AISI 316

Telaio regolabile porta zattera in acciaio inox Aisi 316 tubo ø 30mm.

Fabbricato in tubo di acciaio inox.
Privo di antifurto.

Adjustable liferaft cradle Aisi 316 stainless steel pipe ø 30mm.

Pipe in stainless steel.
Without antitheft device.

| Articolo - Item | €/kit | H cm. | Width cm. | Length cm. |
|-----------------|-------|-------|-----------|------------|
| S 47 00 075 | | 20-40 | 40-54 | 72-87 |

Montaggio pulpito piano-parete - Vertical, horizontal or pushpit mounting



**ATTACCHI IN PLASTICA
PLASTIC CLAMPS**

SUGGESTED ITEM

Art. N0200030
(pag. 520)

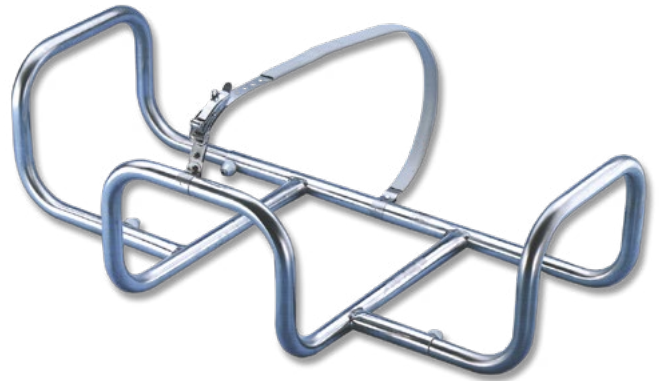
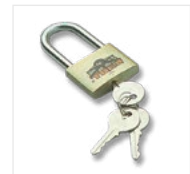

Riflettore radar omologato MED obbligatorio per navigazione da diporto oltre 12 miglia «NAVY STAR»

Superficie massima di riflessione 10 mq.
 Fabbricato in lega leggera, resistente alla corrosione.
 Provvisto di terminali di protezione in materiale plastico.
 Questo dispositivo ha lo scopo di aumentare la sagoma di riflessione delle imbarcazioni con scarse proprietà di riflessione.

Radar reflector MED approved, compulsory for pleasure marine over 12 miles «NAVY STAR»

Reflection up to 10 mq.
 Manufactured in light alloy.
 Corrosion resistant.
 Provided with head plastic protection.
 Folding model for easy storage when not required.

| Articolo - Item | €/pc. | Mod. | Ø mm. |
|-----------------|-------|--|-------|
| L 34 01 012 | | Riflettore radar omologato Med Radar reflector Med approved | 320 |
| L 34 02 320 | | Riflettore radar completo di contenitore a cupola mod. Med Radar reflector supplied with container and fastening mod. Med | 360 |

RIFLETTORE RADAR OMOLOGATO PER MARINA DA DIPORTO CONFORME AL DECRETO MINISTERIALE N° 386 DEL 29/9/1999.
 APPROVATO DAL COMANDO CENTRALE DELLE CAPITANERIE DI PORTO CON DECRETO N° 1293/2005.
 OMOLOGATO MED DIR.96/98CE - USCG

APPROVED MERCHANT SHIPPING RADAR REFLECTOR COMPLYING WITH INTERNATIONAL RULES



CONFEZIONE KIT DI MONTAGGIO IN BLISTER

PACKING IN BLISTER

Direttiva 96/98/EC
 modificata dalla
 Direttiva 2012/32UE
 Annex A1/1.33
 Approvato USCG

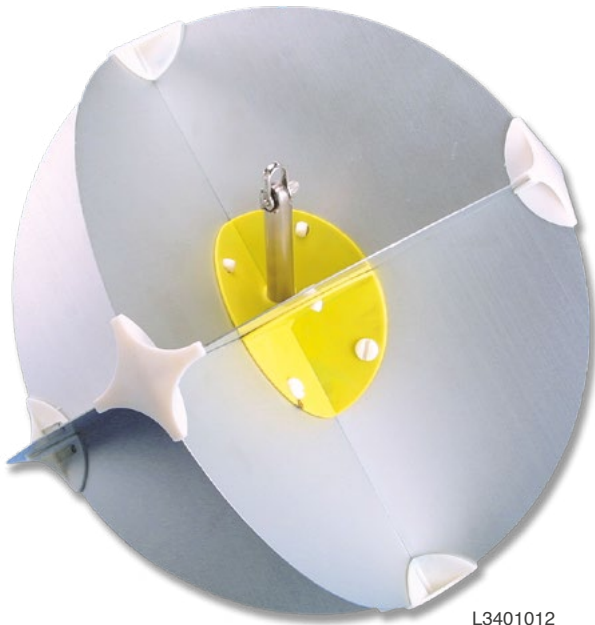

L3401012



L3402320

SICUREZZA | SAFETY

Accessori montaggio Riflettore radar omologato MED

Accessory for radar reflector MED approved

| Articolo - Item | €/pc. | Mod. |
|-----------------|-------|---|
| L 34 03 150 | | Asta telescopica porta riflettore per zattera-Poles reflector holders for liferat 150 cm. |
| L 34 02 012 | | Attacco per cavetto (barche a vela)-Bracket for sailboat version |
| L 34 03 012 | | Attacco a basetta (barche a motore)-Bracket for powerboat version |
| L 34 04 012 | | Attacco a morsetto Ø 22 - 28-Clamp for pipes Ø 22 to 28 mm. |



L3402012



L3403012



L3404012

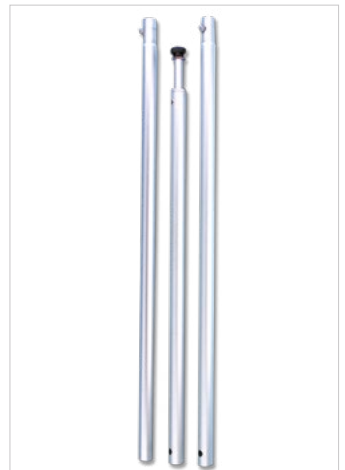

L3403150

RIFLETTORI RADAR E SEGNALI DIURNI | RADAR REFLECTORS

Riflettore radar

Riflettore radar tubolare per barche a vela.

Radar reflector

Tubular radar reflector for sailing boats.

| Articolo - Item | €/pc. | Ø mm. | H mm. | Riflesso Radar |
|-----------------|-------|-------|-------|----------------|
| L 34 05 620 | | 50 | 570 | 2,5 miles |

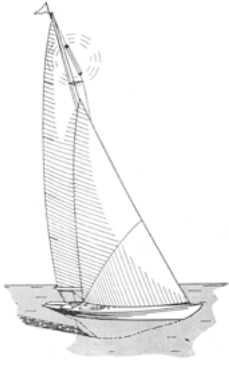

Riflettore radar

Riflettore radar tubolare con base per barche a motore.

Radar reflector

Tubular radar reflector with base for power boats.

| Articolo - Item | €/pc. | Ø mm. | H mm. | Riflesso Radar |
|-----------------|-------|-------|-------|----------------|
| L 34 02 051 | | 50 | 570 | 2,5 miles |

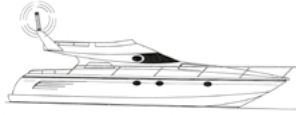

Attacco a basetta per riflettori radar tubolari

Per barche a motore. Fabbriato in nylon antiurto e completo di viteria inox per il montaggio.

Stainless steel fastening base for tubular radar reflector

Suitable for power boats. In shockproof nylon complete with stainless steel screws for fastening.

| Articolo - Item | €/pc. | kg. |
|-----------------|-------|-------|
| L 34 15 050 | | 0,120 |



Riflettore radar

Riflettore radar classico in alluminio. Conforme al Regolamento R.O.R.C.

Radar reflector

Made of aluminium. In compliance with R.O.R.C.

| Articolo - Item | €/pc. | mm. | kg. |
|-----------------|-------|-------------|-----|
| L 34 00 041 | | 220x220x300 | 20 |
| L 34 00 043 | | 290x290x400 | 10 |
| L 34 00 046 | | 340x340x470 | 10 |



Segnale cono

Segnale diurno in plastica a forma di cono. Smontabile e pieghevole per un facile stoccaggio.

Plastic cone signal

Can be dismantled for easy stowage.

| Articolo - Item | €/pc. | H mm. |
|-----------------|-------|-------|
| L 34 00 470 | | 470 |



Segnale pallone

Segnale diurno in plastica a forma di pallone. Smontabile e pieghevole per un facile stoccaggio.

Plastic ball signal

Can be dismantled for easy stowage.

| Articolo - Item | €/pc. | Mod. | Ø mm. |
|-----------------|-------|---------------|-------|
| L 34 00 350 | | Regolamentare | 350 |
| L 34 00 300 | | Pesca-Fishing | 300 |



ELIOGRAFI | SIGNALLING MIRRORS

Specchio da segnalazione

Specchio che riflette i raggi solari, segnala la posizione della barca o del naufrago.

Eliograph signalling mirror

Made of special unbreakable plastic, high corrosive resistance and highly reflective.

| Articolo - Item | €/pc. | Ø mm. |
|-----------------|-------|-------|
| L 34 85 000 | | 85 |



Specchio di segnalazione «Eliografo» approvato

Fabbriato in materiale plastico infrangibile.

Approved Eliograph signalling mirror

Made of special unbreakable plastic, high corrosive resistance and highly reflective.

| Articolo - Item | €/pc. | Mod. | mm. | kg. |
|-----------------|-------|--------------------|---------|-------|
| L 34 10 000 | | Approvato-Approved | 100x100 | 0,060 |





Scala di emergenza «HELP»

Fabbricata con cinghia di poliestere e gradini in plastica antiurto. Completa di sacco di tela.

Emergency ladder «HELP»

Manufactured in nylon belt and plastic steps. With cloth bag.

| Articolo - Item | €/pc. | N. gradini-Steps | H mm. | Larg. mm. |
|-----------------|-------|------------------|-------|-----------|
| S 16 30 005 | | 5 | 1450 | 260 |
| S 16 30 006 | | 6 | 1710 | 260 |
| S 16 30 007 | | 7 | 1970 | 260 |
| S 16 30 008 | | 8 | 2230 | 260 |
| S 16 30 009 | | 9 | 2490 | 260 |



RESCUE LADDER



Scala di emergenza «T-FLEX»

Fabbricata in poliestere UV resistant. Fissaggio a pulpito tramite grilli Aisi 316. Gradini rigidi rinforzati con fibra di vetro. Conforme alla normativa EU ISO 15085:2003 e 2017.

Emergency ladder «T-FLEX»

Manufactured in UV resistant polyester. Pushpit fastening system by Aisi 316 shackles. Fibre-glass reinforced steps. In compliance with new EU ISO 15085:2003 and 2017.

| Articolo - Item | €/pc. | N. gradini-Steps | H mm. | Larg. mm. |
|-----------------|-------|------------------|-------|-----------|
| S 16 11 340 | | 11 | 3400 | 260 |



Conforme alla normativa EU ISO 15085:2003 e 2017

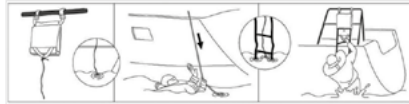

Scala di salvataggio «EMERGENCY LADDER»

Fabbricata in nylon con gradini in plastica. Completa di sacco di tela.

«EMERGENCY LADDER»

Manufactured in nylon belt and plastic steps. With cloth bag.

| Articolo - Item | €/pc. | N. gradini-Steps | Valigia Case mm. | H mm. | Larg. mm. | kg. | kg. |
|-----------------|-------|------------------|------------------|-------|-----------|-----|-------|
| S 16 10 240 | | 10 | 47x20x5 | 2500 | 500 | 175 | 0,780 |



BINOCOLI | BINOCULARS

Binocolo 10 x 50

Rivestito in gomma colore nero.
Completo di tracolla e custodia.

| Articolo - Item | €/pc. | kg. |
|-----------------|-------|-------|
| L 29 10 050 | | 0,550 |



Binocular 10 x 50

Black rubber arming.
With carrying case and strips.

Binocolo «Pegasus» R-line zoom 8-20 x 50 prismi BK-7

Binocolo con rivestimento in gomma colore nero, resistente agli urti.
Completo di tracolla, custodia morbida e maniglia di sicurezza.

| Articolo - Item | €/pc. | mm. | kg. |
|-----------------|-------|---------|-------|
| L 29 00 081 | | 175x185 | 1,290 |



Binocular «Pegasus» R-Line Zoom 8-20X50

Black rubber arming, shock resistant, with prism BK-7.
Lens coating Magenta. Supplied with carrying case and strip.

Binocolo Autofocus 7 x 50

Rivestito in gomma colore nero.
Completo di tracolla e custodia.

| Articolo - Item | €/pc. | Messa a fuoco Focus | Prismi | Campo di visione Vision field | | kg. |
|-----------------|-------|-------------------------------|--------|-------------------------------|--------------|-------|
| | | | | 1000m | mm. | |
| L 29 60 177 | | Automatic (min. distance 12m) | BK-7 | 115,3 m (6,6°) | 200x200 x80H | 0,960 |



WATER RESISTANT

made by



Binocular Autofocus 7 x 50

Black rubber arming.
With carrying case and strips.

Binocolo Autofocus 7 x 50 Professionale

Completamente a tenuta stagna. Lenti anti riflesso "Ruby Coating". Rivestito in gomma colore nero. Completo di tracolla e custodia.

| Articolo - Item | €/pc. | Messa a fuoco Focus | Prismi | Campo di visione Vision field | |
|-----------------|-------|-------------------------------|--------|-------------------------------|-------------|
| | | | | 1000m | mm. |
| L 29 60 084 | | Automatic (min. distance 12m) | BK-7 | 116 m | 220x210x85H |



WATERPROOF

made by



Binocular Autofocus 7 x 50 Professional

Fully waterproof. Anti-reflex lenses "Ruby Coating". Black rubber arming. With carrying case and strips.

Binocolo Autofocus 7 x 50 Professionale con bussola

Completamente a tenuta stagna. Riempito all'interno con gas nitrogene. Completo di bussola di rilevamento con illuminazione e di reticolo per misurare le distanze. Ottica di grande qualità. Lenti anti riflesso "Ruby Coating". Rivestito in gomma colore nero. Completo di tracolla e custodia.

| Articolo - Item | €/pc. | Messa a fuoco Focus | Prismi | mm. | kg. |
|-----------------|-------|----------------------|--------|--------------|-------|
| | | | | | |
| L 29 60 055 | | Automatica e oculare | BaK-4 | 220x240x110H | 1,390 |



WATERPROOF

made by



Binocular Autofocus 7 x 50 Professional with compass

Fully waterproof. Anti-reflex lenses "Ruby Coating". Black rubber arming. With carrying case and strips.

BATISCOPIO | VIEW FINDER

Batiscopio

Realizzato in plastica.
Lente in Policarbonato.

| Articolo - Item | €/pc. | cm. |
|-----------------|-------|-------|
| B 38 25 110 | | 63x34 |



View finder

In plastic.
Polycarbonate glass.



Squadra nautica con maniglia

Fabbricata in plexiglas trasparente. Provvista di divisione goniometrica e graduazione in millimetri. Provvista di manigliette di presa. Doppio goniometro incorporato.

| Articolo - Item | €/pc. | Length mm. | kg. |
|-----------------|-------|------------|-------|
| L 30 00 008 | | 250 | 0,080 |



Plexiglass triangular protractor

Manufactured in plexiglass. Suitable for plotting, fitted with contrasting handle, double built-in goniometer.

Rapportatore nautico

Fabbricato in plexiglas trasparente. Permette di misurare le distanze, trasportare un punto rilevato, correggere la declinazione.

| Articolo - Item | €/pc. | Mod. | Length mm. | kg. |
|-----------------|-------|------------------|------------|-------|
| L 30 00 150 | | Italiano-Italian | 350 | 0,150 |
| L 30 13 150 | | Inglese-English | 350 | 0,150 |

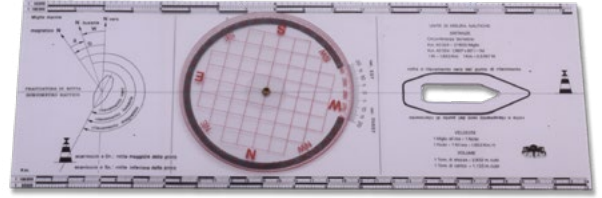

Parallel rule Integral plotter

Manufactured in plexiglass. Suitable for measuring distances, adjust variations, transport a fixing point.

Parallele a rulli millimetricate

Fabbricate in plexiglas trasparente.

| Articolo - Item | €/pc. | Length mm. | kg. |
|-----------------|-------|------------|-------|
| L 32 00 040 | | 450 | 0,400 |



Plexiglass rolling plotter

Manufactured in transparent plexiglass.

Set carteggio nautico

Custodia in Pvc contenente tutto il necessario per il carteggio: parallele, squadra, goniometro, compasso, rapportatore, matita, gomma.

| Articolo - Item | €/set. | Mod. | Busta-Bag cm. | kg. |
|-----------------|--------|------------------|---------------|-------|
| L 31 16 038 | | Italiano-Italian | 16x38x2 | 0,300 |
| L 31 13 038 | | Inglese-English | 16x38x2 | 0,300 |



Navigation chart set

Pvc case, including: parallel, square, goniometer, compass, plotter, pencil and rubber.

Compasso satinato

| Articolo - Item | €/pc. | Length mm. | kg. |
|-----------------|-------|------------|-------|
| L 31 18 281 | | 180 | 0,100 |



Compass with protected points

Manufactured in chromium plated brass.

Compasso speciale carteggio

Fabbricato in ottone cromato. Modello di estrema praticità.

| Articolo - Item | €/pc. | Length Chiuso-Closed mm. | kg. |
|-----------------|-------|--------------------------|-------|
| L 31 18 090 | | 180 | 0,120 |



Compass with protected points

Manufactured in chromium plated brass.

Compasso «Standard»

Fabbricato in ottone cromato con punte in acciaio speciale.

| Articolo - Item | €/pc. | Length mm. | kg. |
|-----------------|-------|------------|-------|
| L 30 00 100 | | 170 | 0,120 |



Compass «Standard»

Manufactured in chromium plated brass.

Compasso ad apertura rapida

Fabbricato in ottone cromato. Modello di estrema praticità perchè consente l'uso con una sola mano.

| Articolo - Item | €/pc. | Length Chiuso-Closed mm. | kg. |
|-----------------|-------|--------------------------|-------|
| L 31 00 018 | | 180 | 0,140 |



Quick opening compass

Manufactured in chromium plated brass. Very useful model, could be used with one hand.

SERIES GOLD 3"

Termo Igrometro
Thermo Hygrometer

| Articolo - Item | €/pc. | kg. |
|-----------------|-------|-------|
| L 27 80 000 | | 0,700 |



SERIES GOLD 3"

Barometro
Barometer

| Articolo - Item | €/pc. | kg. |
|-----------------|-------|-------|
| L 26 80 000 | | 0,720 |



SERIES GOLD 3"

Orologio
Clock

| Articolo - Item | €/pc. | kg. |
|-----------------|-------|-------|
| L 28 80 000 | | 0,700 |



SERIES GOLD 3"

Orologio con periodi silenzio radio
Silent zone clock

| Articolo - Item | €/pc. | kg. |
|-----------------|-------|-------|
| L 28 80 120 | | 0,600 |



SERIES SILVER 3"

Termo Igrometro
Thermo Hygrometer

| Articolo - Item | €/pc. | kg. |
|-----------------|-------|-------|
| L 27 80 118 | | 0,700 |



SERIES SILVER 3"

Barometro
Barometer

| Articolo - Item | €/pc. | kg. |
|-----------------|-------|-------|
| L 26 80 118 | | 0,720 |



SERIES SILVER 3"

Orologio con periodi silenzio radio
Silent zone clock

| Articolo - Item | €/pc. | kg. |
|-----------------|-------|-------|
| L 28 80 118 | | 0,600 |



LET'S STAY IN TOUCH
& FOLLOW US ON SOCIAL MEDIA!



@TremItaly
#tremitaly

BANDIERE STAMPATE IN STAMINA DI POLIESTERE PESANTE | FLAGS IN HEAVY POLYESTER
Codice di navigazione internazionale

Bandiere fabbricate in poliestere.

| Articolo - Item | €/pc. | Bandiera codice Code flags | ↕ mm. | 📦 kg. |
|-----------------|-------|----------------------------|---------|-------|
| N 21 01 040 | | A | 300x450 | 0,050 |
| N 21 03 040 | | C | 300x450 | 0,050 |
| N 21 14 040 | | N | 300x450 | 0,050 |
| N 54 77 045 | | Q | 300x450 | 0,050 |
| N 21 22 040 | | V | 300x450 | 0,050 |
| N 21 03 060 | | C | 500x600 | 0,050 |
| N 21 14 060 | | N | 500x600 | 0,050 |



International navigation code

Flags in polyester.

Bandiere

Con cordino di fissaggio.

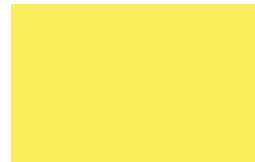
| Articolo - Item | €/pc. | Mod. | ↕ mm. | 📦 kg. |
|-----------------|-------|----------------------|---------|-------|
| N 54 77 030 | | Giallo dogana-Yellow | 200x300 | 0,050 |
| N 54 34 030 | | Pirati-Jolly Roger | 200x300 | 0,050 |
| N 54 34 045 | | Pirati-Jolly Roger | 300x450 | 0,050 |
| N 54 82 060 | | Rosso-Red | 600x600 | 0,050 |



N5477030



N5434030-045



N5482060

Set bandiere (Francia)

Il set comprende 3 bandiere regolamentari N C e nazionale (Francia).

| Articolo - Item | €/pc. | ↕ mm. | 📦 kg. |
|-----------------|-------|---------|-------|
| N 21 50 060 | | 500x600 | 0,200 |

Flag set (France)

Includes 3 regulation flags N C and national (France).

Navigazione «Gran Pavese»

Composta da 40 pezzi del Codice Internazionale di Navigazione. In tela di cotone stampato.

| Articolo - Item | €/pc. | ↕ mm. | Mod. |
|-----------------|-------|---------|----------|
| N 21 15 120 | | 150x200 | Standard |
| N 21 20 130 | | 200x300 | Extra |

Navigation code «Gran Pavese»

Complete with 40 flags of the International Navigation Code. Made of printed cotton.

Bandiera di protesta

Fabricata in nylon di colore rosso. Conforme alle normative di competizione.

| Articolo - Item | €/pc. | €/box 12 pc. | ↕ mm. | 📦 kg. |
|-----------------|-------|--------------|---------|-------|
| N 20 00 035 | | | 150x200 | 0,035 |
| N 20 20 030 | | | 200x300 | 0,055 |

Protest flag

Made of red nylon fabric. In accordance with racing rules.

Bandiera sub

Con cordino di fissaggio.

| Articolo - Item | €/pc. | ↕ mm. | 📦 kg. |
|-----------------|-------|---------|-------|
| N 54 74 030 | | 200x300 | 0,200 |

Sub flag

With line to fix the flag.

BANDIERE STAMPATE IN STAMINA DI POLIESTERE LEGGERA | FLAGS IN LIGHT POLYESTER

Italia - Italy NEW

| Articolo - Item | €/pc. | ↑ mm. |
|-----------------|-------|---------|
| N 21 22 130 | | 200x300 |
| N 21 22 145 | | 300x450 |



Italia Mercantile - Italy

| Articolo - Item | €/pc. | ↑ mm. |
|-----------------|-------|---------|
| N 21 20 300 | | 200x300 |
| N 21 30 450 | | 300x450 |
| N 21 40 600 | | 400x600 |



Finlandia - Finland NEW

| Articolo - Item | €/pc. | ↑ mm. |
|-----------------|-------|---------|
| N 21 25 130 | | 200x300 |
| N 21 25 145 | | 300x450 |



Croazia - Croatia NEW

| Articolo - Item | €/pc. | ↑ mm. |
|-----------------|-------|---------|
| N 21 11 130 | | 200x300 |
| N 21 11 145 | | 300x450 |



Polonia - Poland NEW

| Articolo - Item | €/pc. | ↑ mm. |
|-----------------|-------|---------|
| N 21 24 130 | | 200x300 |
| N 21 24 145 | | 300x450 |



Germania - Germany NEW

| Articolo - Item | €/pc. | ↑ mm. |
|-----------------|-------|---------|
| N 21 01 130 | | 200x300 |
| N 21 01 145 | | 300x450 |



Austria NEW

| Articolo - Item | €/pc. | ↑ mm. |
|-----------------|-------|---------|
| N 21 02 130 | | 200x300 |
| N 21 02 145 | | 300x450 |



Grecia - Greece NEW

| Articolo - Item | €/pc. | ↑ mm. |
|-----------------|-------|---------|
| N 21 08 130 | | 200x300 |
| N 21 08 145 | | 300x450 |



Norvegia - Norway NEW

| Articolo - Item | €/pc. | ↑ mm. |
|-----------------|-------|---------|
| N 21 28 130 | | 200x300 |
| N 21 28 145 | | 300x450 |



Slovenia NEW

| Articolo - Item | €/pc. | ↑ mm. |
|-----------------|-------|---------|
| N 21 12 130 | | 200x300 |
| N 21 12 145 | | 300x450 |



Francia - France NEW

| Articolo - Item | €/pc. | ↑ mm. |
|-----------------|-------|---------|
| N 21 04 130 | | 200x300 |
| N 21 04 145 | | 300x450 |



Ungheria - Hungary NEW

| Articolo - Item | €/pc. | ↑ mm. |
|-----------------|-------|---------|
| N 21 09 130 | | 200x300 |
| N 21 09 145 | | 300x450 |



BANDIERE STAMPATE IN STAMINA DI POLIESTERE PESANTE | FLAGS IN HEAVY POLYESTER

Italia Mercantile - Italy

| Articolo - Item | €/pc. | ↑ mm. |
|-----------------|-------|----------|
| N 21 02 030 | | 200x300 |
| N 21 03 045 | | 300x450 |
| N 21 70 100 | | 700x1000 |



Europa - Europe

| Articolo - Item | €/pc. | ↑ mm. |
|-----------------|-------|---------|
| N 54 20 031 | | 200x300 |
| N 54 30 046 | | 300x450 |



Europa+Italia - Europe+Italy

| Articolo - Item | €/pc. | ↑ mm. |
|-----------------|-------|----------|
| N 54 20 030 | | 200x300 |
| N 54 30 045 | | 300x450 |
| N 54 70 100 | | 700x1000 |



Corsica - Corse

| Articolo - Item | €/pc. | ↑ mm. |
|-----------------|-------|---------|
| N 54 13 030 | | 200x300 |



Sardegna - Sardinia

| Articolo - Item | €/pc. | ↑ mm. |
|-----------------|-------|---------|
| N 54 37 030 | | 200x300 |



Germania - Germany

| Articolo - Item | €/pc. | ↑ mm. |
|-----------------|-------|---------|
| N 54 01 030 | | 200x300 |
| N 54 01 045 | | 300x450 |



Austria

| Articolo - Item | €/pc. | ↑ mm. |
|-----------------|-------|---------|
| N 54 02 030 | | 200x300 |
| N 54 02 045 | | 300x450 |



Russia

| Articolo - Item | €/pc. | ↑ mm. |
|-----------------|-------|---------|
| N 54 19 030 | | 200x300 |
| N 54 19 045 | | 300x450 |



Belgio - Belgium

| Articolo - Item | €/pc. | ↑ mm. |
|-----------------|-------|---------|
| N 54 07 030 | | 200x300 |
| N 54 07 045 | | 300x450 |



Croazia - Croatia

| Articolo - Item | €/pc. | ↑ mm. |
|-----------------|-------|---------|
| N 54 11 030 | | 200x300 |
| N 54 11 045 | | 300x450 |



Polonia - Poland

| Articolo - Item | €/pc. | ↑ mm. |
|-----------------|-------|---------|
| N 54 24 030 | | 200x300 |
| N 54 24 045 | | 300x450 |



Elba

| Articolo - Item | €/pc. | ↑ mm. |
|-----------------|-------|---------|
| N 54 31 030 | | 200x300 |



Gran Bretagna - UK

| Articolo - Item | €/pc. | ↑ mm. |
|-----------------|-------|---------|
| N 54 10 030 | | 200x300 |
| N 54 10 045 | | 300x450 |



Grecia - Greece

| Articolo - Item | €/pc. | ↑ mm. |
|-----------------|-------|---------|
| N 54 08 030 | | 200x300 |
| N 54 08 045 | | 300x450 |



Malta

| Articolo - Item | €/pc. | ↑ mm. |
|-----------------|-------|---------|
| N 54 15 030 | | 200x300 |
| N 54 15 045 | | 300x450 |



Norvegia - Norway

| Articolo - Item | €/pc. | ↑ mm. |
|-----------------|-------|---------|
| N 54 28 030 | | 200x300 |
| N 54 28 045 | | 300x450 |



Danimarca - Denmark

| Articolo - Item | €/pc. | ↑ mm. |
|-----------------|-------|---------|
| N 54 26 045 | | 300x450 |



Olanda - Netherlands

| Articolo - Item | €/pc. | ↑ mm. |
|-----------------|-------|---------|
| N 54 16 030 | | 200x300 |
| N 54 16 045 | | 300x450 |



Slovenia

| Articolo - Item | €/pc. | ↑ mm. |
|-----------------|-------|---------|
| N 54 12 030 | | 200x300 |
| N 54 12 045 | | 300x450 |



Svezia - Sweden

| Articolo - Item | €/pc. | ↑ mm. |
|-----------------|-------|---------|
| N 54 27 030 | | 200x300 |
| N 54 27 045 | | 300x450 |



Stati Uniti - USA

| Articolo - Item | €/pc. | ↑ mm. |
|-----------------|-------|---------|
| N 54 21 030 | | 200x300 |
| N 54 21 045 | | 300x450 |



Svizzera - Switzerland

| Articolo - Item | €/pc. | ↑ mm. |
|-----------------|-------|---------|
| N 54 05 030 | | 200x300 |
| N 54 05 045 | | 300x450 |



Ungheria - Hungary

| Articolo - Item | €/pc. | ↑ mm. |
|-----------------|-------|---------|
| N 54 09 030 | | 200x300 |
| N 54 09 045 | | 300x450 |



Francia - France

| Articolo - Item | €/pc. | ↑ mm. |
|-----------------|-------|---------|
| N 54 04 030 | | 200x300 |
| N 54 04 045 | | 300x450 |



Spagna - Spain

| Articolo - Item | €/pc. | ↑ mm. |
|-----------------|-------|---------|
| N 54 03 030 | | 200x300 |
| N 54 03 045 | | 300x450 |



BANDIERE E CODICI ADESIVI | FLAGS & ADHESIVE SIGNAL CODES

Bandiera italiana

Italian flag

Bandiera adesiva con stemma della marina mercantile.

Adhesive national flag.

| Articolo - Item | €/pc. | €/box 10 pc | ↑ mm. |
|-----------------|-------|-------------|---------|
| N 21 12 016 | | | 160x120 |
| N 21 20 030 | | | 200x300 |



Bandiera europea

EC flag

| Articolo - Item | €/pc. | €/box 10 pc | ↑ mm. |
|-----------------|-------|-------------|---------|
| N 21 25 016 | | | 160x120 |



Codice internazionale dei segnali

International signal code

Descrizione in tre lingue: Italiano, Francese, Inglese.

Description in Italian, French and English.

| Articolo - Item | €/pc. | €/box 10 pc | ↑ mm. |
|-----------------|-------|-------------|---------|
| D 15 13 017 | | | 170x130 |



Codice internazionale dei segnali con codice Morse

International signal code with Morse Code

Descrizione in Italiano e Inglese.

Description in Italian and English.

| Articolo - Item | €/pc. | €/box 10 pc | ↑ mm. | Lingua Language | kg. |
|-----------------|-------|-------------|---------|-----------------|-------|
| D 15 19 028 | | | 280x190 | English | 0,060 |
| D 15 28 019 | | | 280x190 | Italiano | 0,060 |



Codice dei segnali di regata

Racing code flag

| Articolo - Item | €/pc. | €/box | ↑ mm. | Lingua Language |
|-----------------|-------|-------|---------|-----------------|
| D 26 00 015 | | | 180x160 | Italiano |
| D 25 00 015 | | | 180x160 | Francese |



Divieti autoadesivi

Disco autoadesivo da applicare sull'imbarcazione. Ø 170 mm.

Warning discs

Self-adhesive discs to be fitted on the boat surface. Ø 170 mm.

| Articolo - Item | €/pc. | €/box | Tipo-Type |
|-----------------|-------|-------|------------|
| D 07 00 010 | | | NO WALKING |
| D 08 00 010 | | | NO SMOKING |



Codice bandiere di nazionalità

Self-adhesive international flags

Autoadesivo.

Self-adhesive.

| Articolo - Item | €/pc. | €/box | ↑ mm. |
|-----------------|-------|-------|---------|
| D 15 16 024 | | | 160x240 |



LINEE DI GALLEGGIAMENTO | FLOATING LINES

Linee di galleggiamento dotate di un collante permanente che rende la linea equivalente ad una verniciata. Floating lines equipped with a permanent adhesive which makes the line similar to a painted one.

Linea di galleggiamento decorativa a tre strisce

Floating line with three strips

Film autoadesivo a tre strisce.

Self-adhesive film with three strips.

| Articolo - Item | €/mt. | mt. | H mm. | Colore Colour | kg. |
|-----------------|-------|-----|-------|------------------|-------|
| E 55 50 000 | | 10 | 45 | [Red/White/Blue] | 0,100 |
| E 56 50 000 | | 10 | 45 | [Blue/White/Red] | 0,100 |



Striscia monocolore a due fili

Single colour with two strips

| Articolo - Item | €/mt. | mt. | H mm. | N. fili Strips | kg. |
|-----------------|-------|-----|-------|----------------|-------|
| E 56 02 021 | | 10 | 21 | 2 | 0,090 |



Lettere e numeri adesivi con autoallineamento colore nero

Regolamentari per sigle di immatricolazione secondo le disposizioni del Ministero della Marina.
 Fabbricate in materiale resistente alla salsedine del mare.
Indicate per imbarcazioni canotti e tender.

Registration letters and numbers black colour

Easy to align, suitable for any surface.
 Manufactured in salt-resistant materials.
Suitable for boats and inflatables.

| Lettera - Letter | Imbarcazione - Boat | | Targa e tender - Plate & tender | | | |
|------------------|------------------------------|-------|---------------------------------|-----------------------------|-------|-------------|
| | Articolo - Item H 200 mm. | €/pc. | €/box 10 pc | Articolo - Item H 80 mm. | €/pc. | €/box 10 pc |
| A | N 23 01 010 | | | N 22 01 000 | | |
| B | N 23 02 010 | | | N 22 02 000 | | |
| C | N 23 03 010 | | | N 22 03 000 | | |
| D | N 23 04 010 | | | N 22 04 000 | | |
| E | N 23 05 010 | | | N 22 05 000 | | |
| F | N 23 06 010 | | | N 22 06 000 | | |
| G | N 23 07 010 | | | N 22 07 000 | | |
| H | N 23 08 010 | | | N 22 08 000 | | |
| I | N 23 09 010 | | | N 22 09 000 | | |
| L | N 23 12 010 | | | N 22 12 000 | | |
| M | N 23 13 010 | | | N 22 13 000 | | |
| N | N 23 14 010 | | | N 22 14 000 | | |
| O / 0 | N 23 15 010 | | | N 22 15 000 | | |
| P | N 23 16 010 | | | N 22 16 000 | | |
| R | N 23 18 010 | | | N 22 18 000 | | |
| S | N 23 19 010 | | | N 22 19 000 | | |
| T | N 23 20 010 | | | N 22 20 000 | | |
| U | N 23 21 010 | | | N 22 21 000 | | |
| V | N 23 22 010 | | | N 22 22 000 | | |
| Q | N 23 17 010 | | | N 22 17 000 | | |
| Z | N 23 23 010 | | | N 22 23 000 | | |

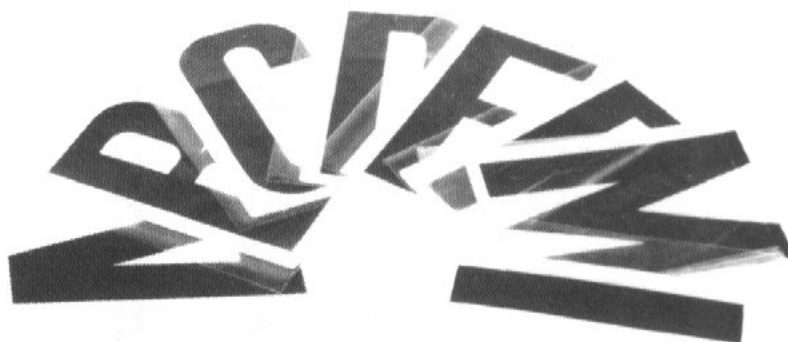

| Lettera - Letter | Imbarcazione - Boat | | Targa e tender - Plate & tender | | | |
|------------------|------------------------------|-------|---------------------------------|-----------------------------|-------|-------------|
| | Articolo - Item H 200 mm. | €/pc. | €/box 10 pc | Articolo - Item H 80 mm. | €/pc. | €/box 10 pc |
| 1 | N 25 01 010 | | | N 22 01 008 | | |
| 2 | N 25 02 010 | | | N 22 02 008 | | |
| 3 | N 25 03 010 | | | N 22 03 008 | | |
| 4 | N 25 04 010 | | | N 22 04 008 | | |
| 5 | N 25 05 010 | | | N 22 05 008 | | |
| 6-9 | N 25 06 010 | | | N 22 06 008 | | |
| 7 | N 25 07 010 | | | N 22 07 008 | | |
| 8 | N 25 08 010 | | | N 22 08 008 | | |

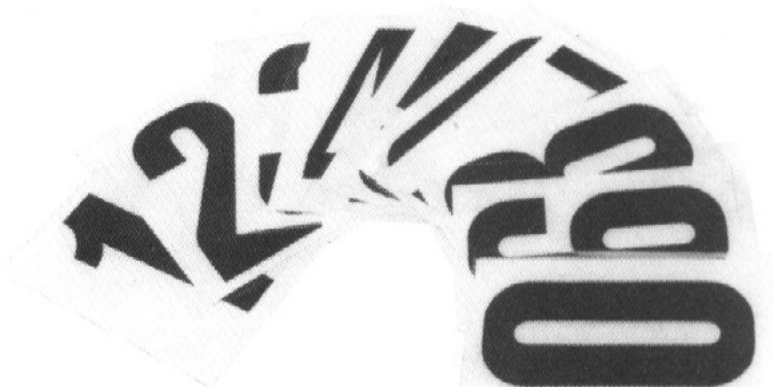

AISI 316

Supporto asta portabandiera da piano

Completo e di viti per il fissaggio in Aisi 316.

Flag pole socket flat mounting

Complete with Aisi 316 fastening screws.

| Articolo - Item | €/pc. | Mod. | Base-Socket Ø mm. | Foro-Hole Ø mm. | kg. |
|-----------------|-------|------------------------|----------------------|--------------------|-------|
| N 21 00 140 | | Diritta-Straight | 60 | 22 | 0,200 |
| N 21 60 000 | | Inclinata-Inclined 10° | 60 | 22 | 0,200 |



N2100140



N2160000

AISI 316

Base asta portabandiera attacco a morsetto

Fabbricata in acciaio inox Aisi 316. Per pulpiti Ø 20-25 mm.

Mast support with clamp socket

Manufactured in Aisi 316 stainless steel. For pushpit Ø 20-25 mm.

| Articolo - Item | €/pc. | Per Asta For Mast Ø mm. | kg. |
|-----------------|-------|----------------------------|-------|
| N 21 22 020 | | 22 | 0,200 |



Base portabandiera indicata per pulpiti

Fabbricata in ottone cromato.

Flag pole socket for pushpit

Manufactured in chromed brass.

| Articolo - Item | €/pc. | Indicata per asta For mast Ø mm. | Tubo-Pipe Ø mm. | kg. |
|-----------------|-------|-------------------------------------|--------------------|-------|
| N 21 20 150 | | 20 | 20-25 | 0,150 |



Base asta portabandiera da piano

Base fabbricata in ottone, inclinata di 10°. Cromata.

Flag pole socket for pushpit

Manufactured in brass, inclined 10°. Chromed model.

| Articolo - Item | €/pc. | Foro-Hole Ø mm. | Base-Socket Ø mm. | kg. |
|-----------------|-------|--------------------|----------------------|-------|
| N 21 25 000 | | 25 | 55 | 0,350 |



Supporto da piano

In acciaio inox Aisi 316 per aste portabandiera.

Pole socket flat mounting

Manufactured in Aisi 316 stainless steel. For flag poles.

| Articolo - Item | €/pc. | Ø mm. | L mm. | W mm. | H mm. |
|-----------------|-------|-------|-------|-------|-------|
| N 21 20 201 | | 20 | 85 | 42 | 44 |
| N 21 25 202 | | 25 | 91 | 46 | 50 |

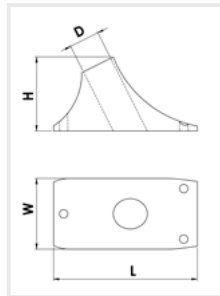

Supporto da pulpito

In acciaio inox Aisi 316 per aste portabandiera.

Flag pole socket for pushpit

Manufactured in Aisi 316 stainless steel. For flag poles.

| Articolo - Item | €/pc. | A mm. | B mm. | C mm. | D mm. |
|-----------------|-------|-------|-------|-------|-------|
| N 21 25 947 | | 25 | 30 | 110 | 70 |

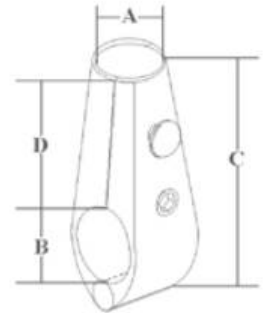

Supporto da incasso

In acciaio inox Aisi 316 con inserto a baionetta per aste portabandiera.

Flush-mount pole socket

Manufactured in Aisi 316 stainless steel. For flag poles.

| Articolo - Item | €/pc. | D mm. | A mm. | B mm. | C mm. |
|-----------------|-------|-------|-------|-------|-------|
| N 21 25 956 | | 25 | 70 | 23 | 55 |

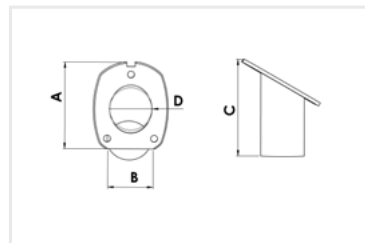

Supporto da piano

In acciaio inox Aisi 316 per aste portabandiera.

Pole socket flat mounting

Manufactured in Aisi 316 stainless steel. For flag poles.

| Articolo - Item | €/pc. | A mm. | B mm. | C mm. |
|-----------------|-------|-------|-------|-------|
| N 21 25 325 | | 25 | 51 | 65 |
| N 21 20 322 | | 22 | 45 | 60 |

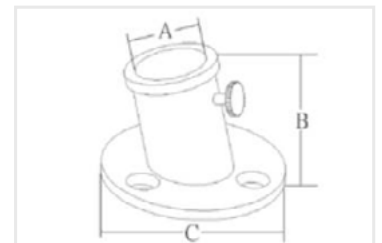

Astina portabandiera «ZODIAC» Mast for flag «ZODIAC»

Fabbricata in plastica nera con base. Made of black plastic with base.

| Articolo - Item | €/pc. | €/box | Length mm. | Base type | kg. |
|-----------------|-------|-------|------------|-------------|-------|
| N 21 40 027 | | | 400 | Poppa-Stern | 0,100 |
| N 21 40 031 | | | 400 | Prua-Bow | 0,100 |



AISI 316

Asta portabandiera con basetta inclinata fissaggio al piano Mast for flags with inclined base flat mounting

Munita di anello bandierina. Provvista di viti inox e basetta.

Provided with flag ring and stainless steel screws.

| Articolo - Item | €/pc. | Length mm. | Astina Mast Ø mm. | kg. |
|-----------------|-------|------------|-------------------|-------|
| N 21 32 060 | | 600 | 22 | 0,180 |
| N 21 32 080 | | 800 | 22 | 0,215 |



COMPLETE WITH
Art. N2160000
(pag. 128)



Asta portabandiera Aisi 316 con basetta fissaggio al piano

Basetta in ottone cromato. Munita di anello bandierina. Provvista di viti inox.

Aisi 316 mast for flags with base flat mounting

Base in chromed brass. Provided with flag ring and stainless steel screws.

| Articolo - Item | €/pc. | Length mm. | Astina Mast Ø mm. | Base mm. | kg. |
|-----------------|-------|------------|-------------------|----------|-------|
| N 21 15 040 | | 400 | 14 | 85x35 | 0,150 |
| N 21 15 050 | | 500 | 14 | 85x35 | 0,200 |



Asta portabandiera con attacco al pulpito Mast for flags for pushpit

Munita di anello bandierina e di viti inox.

Provided with ring and stainless steel screws.

| Articolo - Item | €/pc. | Attacco Ø mm. | Length mm. | Astina Mast Ø mm. | kg. |
|-----------------|-------|---------------|------------|-------------------|-------|
| N 21 40 150 | | 22-25 | 400 | 14 | 0,150 |
| N 21 50 200 | | 22-25 | 500 | 14 | 0,200 |



AISI 316

Asta portabandiera Aisi 316

Base da ordinare a parte.

Mast for flags Aisi 316

Base to be ordered separately.

| Articolo - Item | €/pc. | Length mm. | Ø mm. | kg. |
|-----------------|-------|------------|-------|-------|
| N 21 34 594 | | 600 | 25 | 0,460 |



AISI 316

Asta portabandiera Aisi 316

Munita di occhielli per fissaggio bandiera e viti inox. Base da ordinare a parte.

Mast for flags Aisi 316

Provided with rings and stainless steel screws. Base to be ordered separately.

| Articolo - Item | €/pc. | Length mm. | Ø mm. | kg. |
|-----------------|-------|------------|-------|-------|
| N 21 06 950 | | 600 | 20 | 0,410 |



Asta portabandiera in legno

Completa di bitta per bandiera. Base da ordinare a parte.

Wooden mast for flag

With cleat for flag. Base to be ordered separately.

| Articolo - Item | €/pc. | Length mm. | Ø incasso built-in mm. | Ø esterno outer mm. | Modello Model | kg. |
|-----------------|-------|------------|------------------------|---------------------|---------------|-------|
| N 21 22 060 | | 600 | 22 | 25 | Medium | 0,150 |
| N 21 22 080 | | 800 | 22 | 28 | Medium | 0,200 |
| N 21 28 100 | | 1000 | 22 | 28 | Large | 0,230 |
| N 21 28 125 | | 1250 | 22 | 28 | Large | 0,250 |





GONFIATORI SCOPREGA | INFLATORS

Gonfiatore Bravo 5

Gonfiatore a pedale compatto Bravo 5, adatto come primo equipaggiamento per gommoni, zattere e kayak.

Bravo 5 Foot pump

Bravo 5 compact foot pump suitable as first equipment for inflatables, liferafts and kayaks.

| Articolo - Item | €/pc. | Portata Capacity Lt. | ↑ mm. | Pressione max Max pressure mBar |
|-----------------|-------|----------------------|-------------|---------------------------------|
| Z 06 70 005 | | 5 | 280x200x60H | 200 |



Gonfiatore Bravo 3

Gonfiatore a pedale Bravo 3, completo di raccordi multipli.

Bravo 3 Foot pump

Bravo 3 compact foot pump, complete with multiple fittings.

| Articolo - Item | €/pc. | Portata Capacity Lt. | ↑ mm. | Pressione max Max pressure mBar |
|-----------------|-------|----------------------|-------------|---------------------------------|
| Z 06 70 003 | | 3 | 280x200x60H | 200 |



Gonfiatore Bravo 4

Gonfiatore a mano doppio flusso Bravo 4, completo di raccordi multipli.

Bravo 4 Hand pump

Bravo 4 double action hand pump, complete with multiple fittings.

| Articolo - Item | €/pc. | Portata Capacity Lt./min. | ↑ mm. | Pressione max Max pressure mBar |
|-----------------|-------|---------------------------|--------------|---------------------------------|
| Z 06 20 040 | | 240 | 110x220x400H | 500 |



Gonfiatore Bravo 6

Gonfiatore a mano doppio flusso Bravo 6, completo di raccordi multipli. Tramite un tappo può diventare a flusso semplice per gonfiare alla massima pressione senza sforzo.

Bravo 6 Hand pump

Bravo 6 double action hand pump, complete with multiple fittings. Can be turned into a simple flow inflator allowing to inflate at maximum pressure without effort.

| Articolo - Item | €/pc. | Portata-Capacity Lt./min. | ↑ mm. | Pressione max Max pressure mBar | Mod. |
|-----------------|-------|---------------------------|--------------|---------------------------------|--------------|
| Z 06 20 006 | | 300 | 210x120x470H | 600 | No Manometer |
| Z 06 20 007 | | 300 | 210x120x470H | 600 | Manometer |



Gonfiatore Bravo 4 Alu Red

Gonfiatore a mano doppio flusso Bravo 4 Alu, completo di raccordi multipli. Può gonfiare e sgonfiare, dotato di convertitore a flusso singolo per ridurre lo sforzo e raggiungere la pressione massima.

Bravo 4 Alu Red Hand pump

Bravo 4 Alu double action hand pump, complete with multiple fittings. Can inflate & deflate. Aluminium central axle with automatic switch from double to single flow to reduce stress.

| Articolo - Item | €/pc. | Portata Capacity Lt./min. | ↑ mm. | Pressione max Max pressure mBar |
|-----------------|-------|---------------------------|--------------|---------------------------------|
| Z 06 20 050 | | 240 | 110x220x400H | 800 |



Gonfiatore Bravo 110

Gonfiatore a mano doppio flusso Bravo 110, completo di raccordi multipli, manometro, filtro, base allargata e maniglia ergonomica. Può gonfiare e sgonfiare, dotato di convertitore a flusso singolo per ridurre lo sforzo e raggiungere la pressione massima.

Bravo 110 Hand pump

Bravo 110 double action hand pump, complete with multiple fittings, manometer, filters and ergonomic handle. Can inflate & deflate. With automatic switch from double to single flow to reduce stress.

| Articolo - Item | €/pc. | Portata Capacity Lt./min. | ↑ mm. | Pressione max Max pressure mBar |
|-----------------|-------|---------------------------|--------------|---------------------------------|
| Z 06 20 700 | | 300 | 170x300x580H | 1000 |



Gonfiatore Bravo MB50

Gonfiatore elettrico 12V. Gonfia e sgonfia. Completo di raccordi, attacco per accendisigari.

Bravo MB50 Inflator

Electric inflator 12V. It inflates and deflates. Complete with fittings and cigarette lighter plug.

| Articolo - Item | €/pc. | Mod. | Portata-Capacity Lt./min. | ↑ mm. | Pressione max Max pressure mBar |
|-----------------|-------|--------|------------------------------|--------------|---------------------------------------|
| Z 06 30 008 | | MB8010 | 400 | 125x125x140H | 40 |



Gonfiatore Bravo 2000/220V

Gonfiatore dotato di motore supplementare selezionabile che aumenta la portata e la pressione. Dotato di 3 metri di cavo e fusibili di protezione.

Bravo 2000/220V Inflator

Supplied with a selectable booster to increase flow and pressure. Complete with a 3 mt. cable and protection fuses.

| Articolo - Item | €/pc. | V | W | Portata-Capacity Lt./min. | ↑ mm. | Pressione max Max pressure mBar |
|-----------------|-------|-----|------|------------------------------|--------------|---------------------------------------|
| Z 06 30 200 | | 230 | 1000 | 1800 | 320x170x160H | 230 |



Gonfiatore Bravo BP12

Gonfiatore con arresto automatico alla pressione selezionata. Può gonfiare e sgonfiare. Completo di filtro di aspirazione, raccordi multipli, sacca con tracolla, tubo da 1,70 metri e 3 metri di cavo.

Bravo BP12 Inflator

With automatic stop system when the adjustable pressure is reached. It inflates & deflates. Complete with suction filter, multiple fittings, bag, 1,70 mt. hose, and 3 mt. cable.

| Articolo - Item | €/pc. | V | W | Portata-Capacity Lt./min. | ↑ mm. | Pressione max Max pressure mBar |
|-----------------|-------|----|-----|------------------------------|--------------|---------------------------------------|
| Z 06 30 037 | | 12 | 240 | 120 | 205x105x130H | 1000 |



Gonfiatore Bravo BP12 con manometro

Gonfiatore con arresto automatico alla pressione selezionata tramite manometro con scala in bar e psi. Può gonfiare e sgonfiare. Completo di filtro di aspirazione, raccordi universali, sacca con tracolla, tubo da 1,70 metri e 3 metri di cavo. Privo di batteria integrata.

Bravo BP12 Manometer inflator

With automatic stop manometer when the adjustable pressure is reached. It inflates & deflates. Complete with suction filter, multiple fittings, bag, 1,70 mt. hose, and 3 mt. cable. Without built-in power battery.

| Articolo - Item | €/pc. | V | W | Portata-Capacity Lt./min. | ↑ mm. | Pressione max Max pressure mBar |
|-----------------|-------|----|-----|------------------------------|--------------|---------------------------------------|
| Z 06 30 038 | | 12 | 240 | 420 | 205x105x130H | 1000 |



Gonfiatore Bravo 20

Gonfiatore elettrico per gommoni con arresto automatico alla pressione selezionata. Completo di raccordi universali, morsetti per attacco alla batteria e filtro protettivo. Batteria integrata ricaricabile da presa accendisigari. Completo di sacca con tracolla.

Bravo 20 Inflator

With automatic stop system when the adjustable pressure is reached. Complete with protection filter, universal fittings, battery clamps, bag. Rechargeable integrated battery.

| Articolo - Item | €/pc. | Amp. | W | Portata-Capacity Lt./min. | ↑ mm. | Pressione max Max pressure mBar |
|-----------------|-------|------|-----|------------------------------|--------------|---------------------------------------|
| Z 06 30 700 | | 9 | 108 | 125 | 220x320x220H | 1500 |



Gonfiatore Bravo Turbo Max

Gonfiatore elettrico 12V ad alta velocità. Gonfia in 7 minuti un gommone da 7 metri. Completo di cavo elettrico e tubo aria da 3 metri. Con borsa tracolla.

Inflator Bravo Turbo Max

High speed 12V electric inflator, it can inflate a 7 mt. inflatable boat in only 7 minutes. Complete with feeding cable and 3 mt. air hose. Supplied with bag.

| Articolo - Item | €/pc. | V | Portata-Capacity Lt./min. | ↑ mm. | Pressione max Max pressure mBar | kg. |
|-----------------|-------|----|------------------------------|--------------|---------------------------------------|-----|
| Z 06 30 022 | | 12 | 250 | 310x180x190H | 1000 | 3,5 |



Tubo per gonfiatore Turbo Max Hose for Inflator Turbo Max

| Articolo - Item | €/pc. | Ø mm. | Length mt. |
|-----------------|-------|-------|---------------|
| Z 06 21 015 | | 25 | 25 |



Gonfiatore Bravo Turbo Max Kit Bravo Turbo Max Kit Inflator

Gonfiatore di bordo 12V per gonfiare e sgonfiare battelli pneumatici. Gonfia in 7 minuti un gommone da 7 metri. Arresto manuale. Completo di staffe e viti per il montaggio a incasso.

High speed 12V electric inflator, it can inflate a 7 mt. inflatable boat in only 7 minutes. Hand stop. Complete with screws for flush-mount.

| Articolo - Item | €/pc. | V | Portata-Capacity Lt./min. | ↑ mm. | H incasso mm. |
|-----------------|-------|----|------------------------------|-------------|------------------|
| Z 06 30 021 | | 12 | 1000 | 300x160x70H | 60 |



Kit per compressore portatile **Portable compressor kit**

Completa di pistola con indicatore di pressione e adattatori per gommoni gonfiabili, gomme autovetture e camion. **Supplied with pressure gauge and accessories.**

| Articolo - Item | €/pc. | kg. |
|-----------------|-------|-------|
| L 15 03 501 | | 0,650 |



Gonfiatore elettrico a 12V.

Fabbricato in fibra di nylon. **Manufactured in nylon fiber.**
 Provvisto di riduzioni. **Supplied with nozzle fittings.**
 Provvisto di attacco accendisigari. **Cigarette lighter plug.**

Electric inflator 12V.

Manufactured in nylon fiber. **Supplied with nozzle fittings.**
 Cigarette lighter plug.

| Articolo - Item | €/pc. | Mod. | kg. |
|-----------------|-------|-----------|-------|
| Z 06 18 544 | | Universal | 0,500 |



Pompa ad aria a doppio effetto **Double flow rib inflator**

Pompa a doppio effetto a 4 litri. **Capacity per each cycle 4 lt.**
 Completa di tubo e raccordi universali. **Supplied with pipe and adapter.**

| Articolo - Item | €/pc. | Portata Capacity lt. | Capacità Capacity lt./min. | kg. |
|-----------------|-------|-------------------------|-------------------------------|-------|
| Z 06 04 200 | | 4 | 200 | 0,580 |



Gonfiatore per canotti

Fabbricato in materia plastica resistente. **Manufactured in strong and resistant plastic material.**
 Il gonfiatore è corredato di tubo flessibile e raccordi universali. **Possibility of inflation/ deflation of boats.**

Inflator for inflatable boats

Manufactured in strong and resistant plastic material. **Possibility of inflation/ deflation of boats.**

| Articolo - Item | €/pc. | Mod. | Portata Capacity lt. | kg. |
|-----------------|-------|-------|-------------------------|-------|
| Z 06 00 130 | | Large | 5 | 1,300 |



Serie beccucci per gonfiatori **Pump neck**

Fabbricati in materiale plastico. **Manufactured in plastic material.**
 Serie di 3 pezzi di diametri diversi. **Packing: 3 pcs./set.**

| Articolo - Item | €/Kit 3 pcs. | kg. |
|-----------------|--------------|-------|
| Z 06 00 006 | | 0,060 |

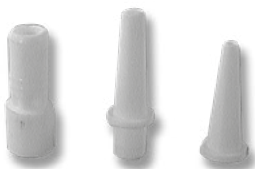

| Maniglia large | | Large size handle | | |
|-----------------|-------|-------------------|------------|-------|
| Articolo - Item | €/pc. | Colore Colour | ↳ mm. | 📦 kg. |
| N 38 28 430 | | Grey Ral 7035 | 290x95x55H | 0,65 |



| Scalmiera fissa | | Rowlock socket | | |
|--|-------|------------------|------------|-------|
| Indicata per scalmi R3235000. Suitable for rowlock R3235000. | | | | |
| Articolo - Item | €/pc. | Colore Colour | ↳ mm. | 📦 kg. |
| N 36 00 200 | | Grey Ral 7035 | 200x95x35H | 0,40 |



| Passacorda grigio | | Fairlead | | |
|-------------------|-------|------------------|-----------|-------|
| Articolo - Item | €/pc. | Colore Colour | ↳ mm. | 📦 kg. |
| N 36 00 095 | | Grey Ral 7035 | 95x95x45H | 0,150 |



| Valvola in nylon per gonfiabili leggeri | | Spare plug & valve for inflatables | | |
|---|-------|------------------------------------|---------|-------|
| Articolo - Item | €/pc. | Foro tessuto Hole Ø mm. | ↳ mm. | 📦 kg. |
| Z 14 00 024 | | 22 | Ø44x38H | 0,100 |



| Chiave per montaggio e rimozione valvole | | Universal valve key | |
|--|-------|---------------------|--|
| Articolo - Item | €/pc. | | |
| Z 14 00 025 | | 0,030 | |



| Valvola gommoni | | Spare valve for ribs | | | |
|---|-------|----------------------|-------|-------|-------|
| Valvola di gonfiaggio e sgonfiaggio per canotti pneumatici. Inflating/deflating valve for inflatable boats. | | | | | |
| Articolo - Item | €/pc. | A mm. | B mm. | C mm. | 📦 kg. |
| Z 14 79 035 | | 64 | 36 | 47 | 0,150 |

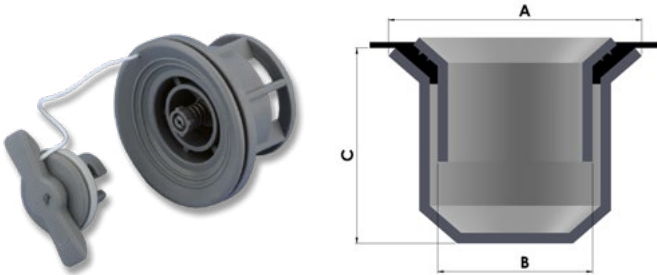

| Valvola gommoni | | Spare valve for ribs | | | |
|--|-------|----------------------|-------|-------|-------|
| Valvola compatta con tappo ergonomico per gonfiabili e fondi ad alta pressione. Con apertura push e guarnizione a labbro a massima tenuta. With ergonomic plug, suitable for high pressure inflatable boats. Universal model, PUSH-PUSH mechanism. | | | | | |
| Articolo - Item | €/pc. | A mm. | B mm. | C mm. | 📦 kg. |
| Z 06 02 700 | | 64 | 36 | 50 | 0,150 |

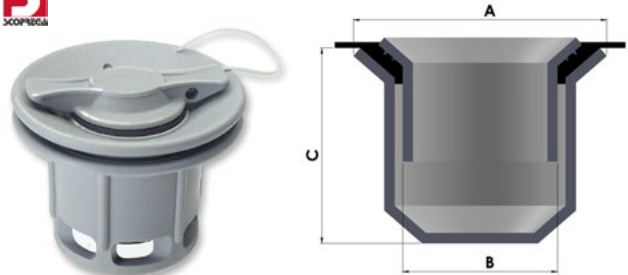

| Attacco per sollevare e trasportare il pram e il tender | | Snap davits set for tender lifting & carrying | | |
|---|-------|---|--|-------|
| Completo di due anelli in acciaio inox da incollare al tender e due ganci in acciaio inox da fissare sulla plancetta o sulla poppa dell'imbarcazione. Release type fastener made of stainless steel. Universal model. To be mounted on the bridge or directly on transom of the boat. | | | | |
| Articolo - Item | €/kit | Colore-Colour | | 📦 kg. |
| O 17 00 036 | | Grigio per Neoprene-Grey for Neoprene | | 2,60 |
| O 17 00 032 | | Bianco per PVC-White for PVC | | 2,65 |



| Coppia aste attacco tender | | Couple of tender poles | |
|--|----------|------------------------|-------|
| Indicate per fissare il tender di servizio in posizione di riposo. To be fixed to the tender when not in use. Fabbricate in acciaio inox e complete di moschettoni alle estremità. Manufactured in stainless steel, with snap-hooks. | | | |
| Articolo - item | €/coppia | ↳ cm. | 📦 kg. |
| O 17 45 071 | | 45 ~ 71 | 0,920 |

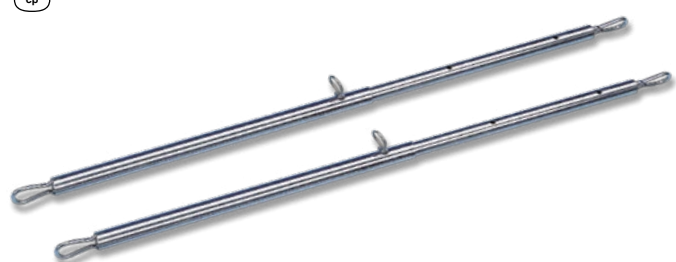

PARABORDI «TR.EM.» | FENDERS BY «TR.EM.»

Parabordi gonfiabili di colore blu in Pvc

Provvisi di una valvola in nylon che dà una grande facilità di gonfiaggio e sgonfiaggio.

Inflatable fender with reinforced eye in Pvc

Provided with a valve constructed to make it easy to inflate and deflate the fenders.

| Articolo - Item | €/pc. | Ø mm. | Length mm. | kg. |
|-----------------|-------|-------|------------|-------|
| P 08 22 063 | | 220 | 690 | 2,200 |

KIT FISSAGGIO PARABORDI | KIT FENDER LINE

Clips fissa parabordi per battagliola

Clips in nylon indicata per fissare i parabordi lungo le battagliole e i tientibene evitando i nodi. Di facile applicazione. Indicata per cime Ø 8-10 mm. Ø tubo 22-25mm.

Fender lock clips

Manufactured in nylon, to be fixed on the rail or hand-rail avoiding knots. Suitable for ropes Ø 8-10 mm. Pipe Ø 22-25mm.

| Articolo - Item | €/serie 2 pz. - Series of 2 pcs. | kg. |
|-----------------|----------------------------------|-------|
| N 53 08 000 | | 0,020 |

PARABORDI GONFIABILI | INFLATABLE FENDERS

Parabordi gonfiabili colore grigio

Fabbricati in PVC a tenuta stagna. Provvisi di valvola in nylon a vite.

Pneumatic fenders grey colour

Pvc inflatables fenders. With screw valve.

| Articolo - Item | €/pc. | Colore Colour | Length mm. | Ø mm. | kg. |
|-----------------|-------|---------------|------------|-------|-------|
| P 20 30 070 | | Grigio - Grey | 700 | 300 | 1,400 |
| P 20 30 110 | | Grigio - Grey | 1100 | 300 | 1,900 |
| P 20 45 170 | | Grigio - Grey | 1700 | 450 | 4,500 |
| P 20 60 182 | | Grigio - Grey | 1820 | 600 | 4,900 |

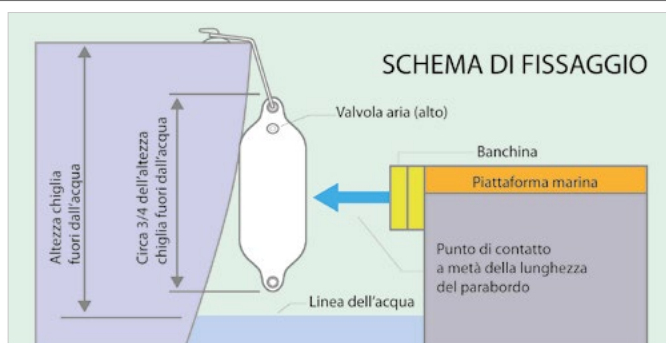
UN'INFORMAZIONE IN PIÙ ...

Per scegliere il giusto parabordo per la vostra imbarcazione, occorre considerare l'altezza visibile della murata rispetto alla superficie dell'acqua. Per un'efficace azione di protezione, il parabordo deve coprire approssimativamente una lunghezza pari ai 3/4 di tale altezza. Inoltre, per non incorrere in problemi con le valvole e per prolungare la vita del parabordo, consigliamo di gonfiarlo in maniera ottimale, non eccessivamente e non troppo poco.

SOME MORE INFORMATION ...

In order to choose the right fender for your boat, it's necessary to know the visible height of the shipside compared with the surface of water. For a better protective performance the fender should cover about 3/4 of such height. Moreover to prevent any problem with the valves and to elongate the working life of the fender, we suggest to blow it not too much and not too low.

**Parabordi Majoni Testa Blu
«Star Fender»**

Con due fori d'attacco.

**Majoni fenders Blue Head
«Star Fender»**

Fitted with double eyelet.

| Articolo - Item | €/pc. | Mod. | Ø mm. | Length mm. | Volume lt. | Suggested Fender cover | Suggested Fender basket | kg. |
|-----------------|-------|------|-------|------------|------------|------------------------|-------------------------|-------|
| P 18 01 100 | | SF1 | 120 | 450 | 4 | P0975045 | - | 0,700 |
| P 18 01 101 | | SF2 | 150 | 580 | 8 | P0975058 | P0632170 | 1,100 |
| P 18 02 102 | | SF2A | 180 | 600 | 13 | P0975059 | P0632185 | 1,300 |
| P 18 01 102 | | SF3 | 210 | 620 | 18 | P0975062 | P0632215 | 1,800 |
| P 18 03 070 | | SF4 | 240 | 700 | 27 | P0975070 | P0642250 | 2,400 |
| P 18 04 090 | | SF5 | 300 | 900 | 56 | P0975091 | P0642305 | 4,000 |
| P 18 05 082 | | CF4 | 300 | 820 | - | - | P0642305 | - |
| P 18 06 110 | | MF1 | 350 | 1100 | - | - | - | - |



SUGGESTED ITEM



Fender Basket (pag. 140)

Fender Cover (pag. 138)

Fender rope (pag. 30)

**Parabordi Majoni Testa Nera
«Star Fender»**

Con due fori d'attacco.

**Majoni fenders Black Head
«Star Fender»**

Fitted with double eyelet.

| Articolo - Item | €/pc. | Mod. | Ø mm. | Length mm. | Volume lt. | Suggested Fender cover | Suggested Fender basket | kg. |
|-----------------|-------|------|-------|------------|------------|------------------------|-------------------------|-------|
| P 13 01 100 | | SF1 | 120 | 450 | 4 | - | - | 0,700 |
| P 13 01 101 | | SF2 | 150 | 580 | 8 | - | P0632170 | 1,100 |
| P 13 02 102 | | SF2A | 180 | 600 | 13 | - | P0632185 | 1,300 |
| P 13 01 102 | | SF3 | 210 | 620 | 18 | - | P0632215 | 1,800 |
| P 13 03 070 | | SF4 | 240 | 700 | 27 | - | P0642250 | 2,400 |
| P 13 04 090 | | SF5 | 300 | 900 | 56 | - | P0642305 | 4,000 |
| P 13 05 082 | | CF4 | 300 | 820 | - | - | P0642305 | - |
| P 13 06 110 | | MF1 | 350 | 1100 | - | - | - | - |



SUGGESTED ITEM



Fender Basket (pag. 140)

Fender Cover (pag. 138)

Fender rope (pag. 30)

**Parabordi Majoni Testa Nera
«Heavy Duty»**

Con due fori d'attacco rinforzati.

**Majoni fenders Black Head
«Heavy Duty»**

Fitted with double reinforced eyelet.

| Articolo - Item | €/pc. | Mod. | Ø mm. | Length mm. | Suggested Fender cover | Suggested Fender basket | kg. |
|-----------------|-------|-------|-------|------------|------------------------|-------------------------|-------|
| P 18 13 540 | | HDF 1 | 130 | 540 | - | - | 0,940 |
| P 18 15 650 | | HDF 2 | 150 | 650 | - | P0632170 | 1,300 |
| P 18 20 750 | | HDF 3 | 200 | 750 | - | P0632215 | 2,240 |
| P 18 25 850 | | HDF 4 | 250 | 850 | - | P0642250 | 3,000 |
| P 18 35 110 | | HDM1 | 350 | 1100 | - | - | - |



SUGGESTED ITEM

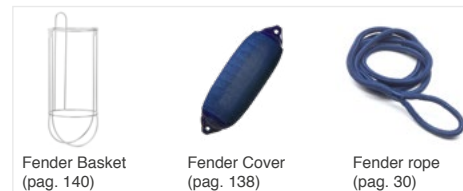

Fender Basket (pag. 140)

Fender Cover (pag. 138)

Fender rope (pag. 30)



**Parabordi Majoni «Star Fender»
colore blu**

Con due fori d'attacco.

| Articolo - Item | €/pc. | Mod. | Ø mm. | Length mm. | Volume lt. | Suggested Fender cover | Suggested Fender basket | kg. |
|-----------------|-------|------|-------|------------|------------|------------------------|-------------------------|-------|
| P 14 12 045 | | SF1 | 120 | 450 | 4 | P0975045 | - | 0,600 |
| P 14 15 058 | | SF2 | 150 | 580 | 8 | P0975058 | P0632170 | 1,100 |
| P 14 18 060 | | SF2A | 180 | 600 | 13 | P0975059 | P0632185 | 1,300 |
| P 14 21 062 | | SF3 | 210 | 620 | 18 | P0975062 | P0632215 | 1,800 |
| P 14 24 070 | | SF4 | 240 | 700 | 27 | P0975070 | P0642250 | 2,400 |
| P 14 30 090 | | SF5 | 300 | 900 | 56 | P0975091 | P0642305 | 4,000 |



SUGGESTED ITEM

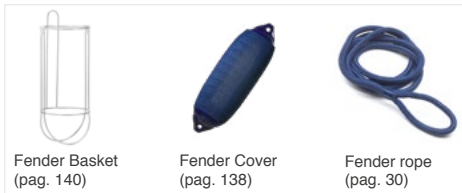

Fender Basket (pag. 140)

Fender Cover (pag. 138)

Fender rope (pag. 30)

**Majoni fenders «Star Fender»
blue colour**

Fitted with double eyelet.



**Parabordi Majoni «Star Fender»
colore bianco**

Con due fori d'attacco.

| Articolo - Item | €/pc. | Mod. | Ø mm. | Length mm. | Volume lt. | Suggested Fender cover | Suggested Fender basket | kg. |
|-----------------|-------|------|-------|------------|------------|------------------------|-------------------------|-------|
| P 15 12 045 | | SF1 | 120 | 450 | 4 | P0975045 | - | 0,600 |
| P 15 15 058 | | SF2 | 150 | 580 | 8 | P0975058 | P0632170 | 1,100 |
| P 15 18 060 | | SF2A | 180 | 600 | 13 | P0975059 | P0632185 | 1,300 |
| P 15 21 062 | | SF3 | 210 | 620 | 18 | P0975062 | P0632215 | 1,800 |
| P 15 24 070 | | SF4 | 240 | 700 | 27 | P0975070 | P0642250 | 2,400 |
| P 15 30 090 | | SF5 | 300 | 900 | 56 | P0975091 | P0642305 | 4,000 |
| P 15 30 082 | | CF4 | 300 | 820 | - | - | P0642305 | - |
| P 15 35 110 | | MF1 | 350 | 1100 | - | - | - | - |



SUGGESTED ITEM

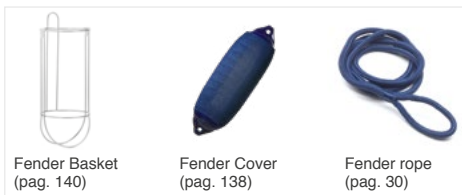

Fender Basket (pag. 140)

Fender Cover (pag. 138)

Fender rope (pag. 30)

**Majoni fenders «Star Fender»
white colour**

Fitted with double eyelet.



**Parabordi Majoni «Star Fender»
colore nero**

Con due fori d'attacco.

| Articolo - Item | €/pc. | Mod. | Ø mm. | Length mm. | Volume lt. | Suggested Fender cover | Suggested Fender basket | kg. |
|-----------------|-------|------|-------|------------|------------|------------------------|-------------------------|-------|
| P 23 12 045 | | SF1 | 120 | 450 | 4 | - | - | 0,600 |
| P 23 15 058 | | SF2 | 150 | 580 | 8 | - | P0632170 | 1,100 |
| P 23 18 060 | | SF2A | 180 | 600 | 13 | - | P0632185 | 1,300 |
| P 23 21 062 | | SF3 | 210 | 620 | 18 | - | P0632215 | 1,800 |
| P 23 24 070 | | SF4 | 240 | 700 | 27 | - | P0642250 | 2,400 |
| P 23 30 090 | | SF5 | 300 | 900 | 56 | - | P0642305 | 4,000 |



SUGGESTED ITEM

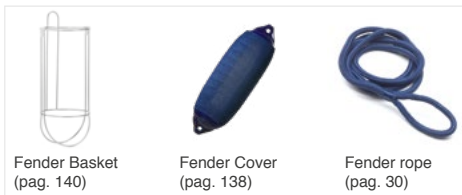

Fender Basket (pag. 140)

Fender Cover (pag. 138)

Fender rope (pag. 30)

**Majoni fenders «Star Fender»
black colour**

Fitted with double eyelet.



P1535100

**Valvola e estrattore per parabordi
Majoni**

Realizzati in ottone.

| Articolo - Item | €/pc. | Mod. | kg. |
|-----------------|-------|---------------|-------|
| P 15 35 100 | | Estrattore | 0,030 |
| P 15 35 101 | | Valvola-Valve | 0,030 |



P1535101

**Majoni fenders «Star Fender»
black colour**

Manufactured in brass.

Parabordi Majoni con cima passante

Con foro passante.

Majoni fenders with loop line

With loop hole.

| Articolo - Item | €/pc. | Mod. | Ø mm. | H mm. | ø foro mm. | Suggested Fender basket | kg. |
|-----------------|-------|------|-------|-------|------------|-------------------------|-------|
| P 15 10 030 | | HF1 | 100 | 300 | 17 | - | 0,500 |
| P 15 15 043 | | HF2 | 150 | 430 | 17 | P0632170 | 0,900 |
| P 15 20 055 | | HF3 | 200 | 550 | 17 | P0632215 | 1,800 |
| P 15 25 068 | | HF4 | 250 | 680 | 17 | P0642250 | 2,400 |
| P 15 30 080 | | HF5 | 300 | 800 | 17 | P0642305 | - |

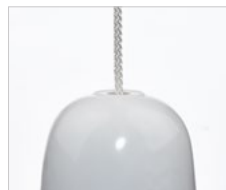

SUGGESTED ITEM



Art. Fender basket (pag. 140)

Parabordi Majoni a sfera rosso/blu

Parabordi a pera di grande robustezza con foro d'attacco rinforzato.

Majoni fenders red & blue

Solid head buoy with reinforced connection eyelet.

| Articolo - Item | €/pc. | Mod. | Ø mm. | H mm. | Galleggiabilità Buoyancy Kg. | Suggested Fender basket | kg. |
|-----------------|-------|-------|-------|-------|------------------------------|-------------------------|-------|
| P 12 35 048 | | RSHB1 | 350 | 480 | 21 | P0975048 | 1,500 |
| P 12 45 062 | | RSHB2 | 450 | 620 | 45 | P0975064 | 2,800 |
| P 12 55 073 | | RSHB3 | 550 | 730 | 83 | P0975073 | 3,800 |
| P 12 65 088 | | RSHB4 | 650 | 880 | 139 | P0975088 | 4,900 |
| P 12 85 105 | | RSHB5 | 850 | 1050 | 314 | P0975105 | 7,500 |

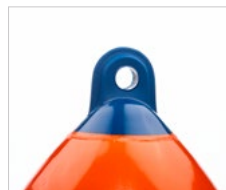

SUGGESTED ITEM



Fender cover (pag. 138)

Fender rope (pag. 30)

Parabordi Majoni a sfera bianco/blu

Parabordi a pera di grande robustezza con foro d'attacco rinforzato.

Majoni fenders white & blue

Solid head buoy with reinforced connection eyelet.

| Articolo - Item | €/pc. | Mod. | Ø mm. | H mm. | Galleggiabilità Buoyancy Kg. | Suggested Fender cover | kg. |
|-----------------|-------|-------|-------|-------|------------------------------|------------------------|-------|
| P 18 35 048 | | WSHB1 | 350 | 480 | 21 | P0975048 | 1,500 |
| P 18 45 062 | | WSHB2 | 450 | 620 | 45 | P0975064 | 2,800 |
| P 18 55 073 | | WSHB3 | 550 | 730 | 83 | P0975073 | 3,800 |
| P 18 65 088 | | WSHB4 | 650 | 880 | 139 | P0975088 | 4,900 |
| P 18 85 105 | | WSHB5 | 850 | 1050 | 314 | P0975105 | 7,500 |

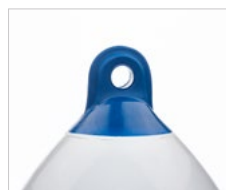

SUGGESTED ITEM



Art. Fender Cover (pag. 138)

Fender rope (pag. 30)

Parabordi Majoni a sfera colore giallo

| Articolo - Item | €/pc. | Mod. | Ø mm. | H mm. | Galleggiabilità Buoyancy Kg. |
|-----------------|-------|------|-------|-------|------------------------------|
| P 22 09 077 | | FB0 | 9 | 11 | 10,00 |
| P 22 15 077 | | FB1 | 15 | 21 | 25,00 |



NEW

SUGGESTED ITEM



Fender rope (pag. 30)



Calze copriparabordi colore blu per Majoni

100% poliestere elasticizzato, lavabile a 40° in lavatrice. Non macchia le fiancate. Dotato di elastico che ne evita la perdita e facilita il montaggio. Elevata resistenza all'usura.

Blue colour protection covers for Majoni fenders

Manufactured in elasticized polyester, non-abrasive fabric. Washable at 40°C. Elasticized bottom edge, high resistant top edge for a perfect fit on every fender.

| Articolo - Item | €/pc. | Mod. | Ø cm. | H cm. |
|------------------------|-------|------|--------|----------|
| P 09 75 045 | | SF1 | 10<>14 | 42<>47 |
| P 09 75 058 | | SF2 | 13<>17 | 55<>60 |
| P 09 75 059 | | SF2A | 16<>20 | 57<>63 |
| P 09 75 062 | | SF3 | 19<>23 | 60<>64 |
| P 09 75 070 | | SF4 | 22<>26 | 68<>73 |
| P 09 75 091 | | SF5 | 27<>32 | 86<>94 |
| P 09 75 082 NEW | | CF4 | 27<>32 | 77<>85 |
| P 09 75 110 NEW | | MF1 | 32<>37 | 105<>115 |



Calze copriparabordi colore blu per Majoni sfera

100% poliestere elasticizzato, lavabile a 40° in lavatrice. Non macchia le fiancate. Dotato di elastico che ne evita la perdita e facilita il montaggio. Elevata resistenza all'usura.

Blue colour protection covers for Majoni fenders

Manufactured in elasticized polyester, non-abrasive fabric. Washable at 40°C. Elasticized bottom edge, high resistant top edge for a perfect fit on every fender.

| Articolo - Item | €/pc. | Mod. | Ø cm. | H cm. |
|-----------------|-------|-------|--------|----------|
| P 09 75 048 | | WSHB1 | 32<>37 | 46<>50 |
| P 09 75 064 | | WSHB2 | 43<>47 | 60<>64 |
| P 09 75 073 | | WSHB3 | 53<>57 | 70<>75 |
| P 09 75 088 | | WSHB4 | 62<>67 | 85<>92 |
| P 09 75 105 | | WSHB5 | 83<>87 | 100<>110 |



Calze copriparabordi colore blu per Polyform serie F-G

100% poliestere elasticizzato, lavabile a 40° in lavatrice. Non macchia le fiancate. Dotato di elastico che ne evita la perdita e facilita il montaggio. Elevata resistenza all'usura.

Blue colour protection covers for Polyform fenders F-G

Manufactured in elasticized polyester, non-abrasive fabric. Washable at 40°C. Elasticized bottom edge, high resistant top edge for a perfect fit on every fender.

| Articolo - Item | €/pc. | Mod. | Ø cm. | H cm. |
|-----------------|-------|-------|--------|----------|
| P 09 75 051 | | F02 | 18<>20 | 62<>66 |
| P 09 75 063 | | F2 | 21<>23 | 60<>64 |
| P 09 75 080 | | F3 | 21<>23 | 72<>78 |
| P 09 75 015 | | F1-G4 | 14<>16 | 58<>62 |
| P 09 75 100 | | F4 | 21<>23 | 100<>108 |
| P 09 75 060 | | F5 | 29<>32 | 74<>78 |
| P 09 75 042 | | G3 | 10<>12 | 40<>50 |



Calze copriparabordi colore blu per Polyform serie A

100% poliestere elasticizzato, lavabile a 40° in lavatrice. Non macchia le fiancate. Dotato di elastico che ne evita la perdita e facilita il montaggio. Elevata resistenza all'usura.

Blue colour protection covers for Polyform fenders A series

Manufactured in elasticized polyester, non-abrasive fabric. Washable at 40°C. Elasticized bottom edge, high resistant top edge for a perfect fit on every fender.

| Articolo - Item | €/pc. | Mod. | Ø cm. | H cm. |
|-----------------|-------|------|--------|--------|
| P 09 75 230 | | A0 | 20<>25 | 25<>32 |
| P 09 75 310 | | A1 | 28<>31 | 36<>39 |
| P 09 75 400 | | A2 | 38<>41 | 48<>51 |
| P 09 75 490 | | A3 | 46<>50 | 58<>62 |
| P 09 75 600 | | A4 | 54<>60 | 68<>73 |



Calze copriparabordi colore bordeaux per Polyform serie F-G

100% poliestere elasticizzato, lavabile a 40° in lavatrice. Non macchia le fiancate. Dotato di elastico che ne evita la perdita e facilita il montaggio. Elevata resistenza all'usura.

Bordeaux colour protection covers for Polyform fenders F-G

Manufactured in elasticized polyester, non-abrasive fabric. Washable at 40°C. Elasticized bottom edge, high resistant top edge for a perfect fit on every fender.

| Articolo - Item | €/pc. | Mod. | Ø cm. | H cm. | kg. |
|-----------------|-------|-------|--------|--------|-------|
| P 09 82 015 | | F1-G4 | 14<>16 | 58<>62 | 0,080 |
| P 09 82 051 | | F02 | 18<>20 | 62<>66 | 0,080 |
| P 09 82 063 | | F2 | 21<>23 | 60<>64 | 0,085 |
| P 09 82 080 | | F3 | 21<>23 | 72<>78 | 0,090 |
| P 09 82 042 | | G3 | 14<>16 | 48<>53 | 0,080 |



Calze copriparabordi colore nero per Polyform serie F-G

100% poliestere elasticizzato, lavabile a 40° in lavatrice. Non macchia le fiancate. Dotato di elastico che ne evita la perdita e facilita il montaggio. Elevata resistenza all'usura.

Black colour protection covers for Polyform fenders F-G

Manufactured in elasticized polyester, non-abrasive fabric. Washable at 40°C. Elasticized bottom edge, high resistant top edge for a perfect fit on every fender.

| Articolo - Item | €/pc. | Mod. | Ø cm. | H cm. | kg. |
|-----------------|-------|------|--------|----------|-------|
| P 09 80 015 | | F1 | 14<>16 | 58<>62 | 0,080 |
| P 09 80 051 | | F02 | 18<>20 | 62<>66 | 0,080 |
| P 09 80 063 | | F2 | 21<>23 | 60<>64 | 0,080 |
| P 09 80 080 | | F3 | 21<>23 | 72<>78 | 0,085 |
| P 09 80 100 | | F4 | 21<>23 | 100<>108 | 0,090 |



CALZE COPRIPARABORDI | PROTECTION COVERS FOR FENDER

Calze copriparabordi felpati colore blu per Polyform serie F

Copriparabordi in resistente tessuto felpato. Proteggono i vostri parabordi evitando loro di usurarsi, di sporcarsi e di cigolare. Morbidi e robusti, non macchiano le fiancate della barca e durano nel tempo. Fatti con 100% tessuto Acrilico di qualità e resistenza superiori.

Blue colour protection covers for Polyform fenders F series

Fender cover made in plushy fabric, 100% high quality and high resistant acrylic. T-Fender are UV resistant and specifically designed and made to be resistant to the marine environment. They are made to save your fenders and your boat.

| Articolo - Item | €/pc. | Mod. | Ø cm. | H cm. | kg. |
|-----------------|-------|------|----------|------------|-------|
| P 09 75 015S | | F1 | 14 <> 16 | 58 <> 62 | 0,120 |
| P 09 75 063S | | F2 | 21 <> 24 | 60 <> 64 | 0,220 |
| P 09 75 080S | | F3 | 21 <> 24 | 72 <> 78 | 0,250 |
| P 09 75 100S | | F4 | 21 <> 23 | 100 <> 108 | 0,320 |



Calze copriparabordi felpati colore blu per Polyform serie A

Copriparabordi in resistente tessuto felpato. Proteggono i vostri parabordi evitando loro di usurarsi, di sporcarsi e di cigolare. Morbidi e robusti, non macchiano le fiancate della barca e durano nel tempo. Fatti con 100% tessuto Acrilico di qualità e resistenza superiori.

Blue colour protection covers for Polyform fenders A series

Fender cover made in plushy fabric, 100% high quality and high resistant acrylic. T-Fender are UV resistant and specifically designed and made to be resistant to the marine environment. They are made to save your fenders and your boat.

| Articolo - Item | €/pc. | Mod. | Ø cm. | H cm. | kg. |
|-----------------|-------|------|----------|----------|-------|
| P 09 75 310S | | A1 | 28 <> 31 | 36 <> 39 | 0,220 |
| P 09 75 400S | | A2 | 38 <> 41 | 48 <> 51 | 0,200 |
| P 09 75 490S | | A3 | 46 <> 50 | 58 <> 62 | 0,330 |



PARABORDI «MAJONI» | FENDERS BY «MAJONI»

Parabordi di prua

Fabbricati in Pvc a tenuta perfettamente stagna. Colore bianco.

Bow fenders

Manufactured in water-proof Pvc. White colour.

| Articolo - Item | €/pc. | Ø | ↑ mm. | kg. |
|-----------------|-------|-----|---------|-------|
| P 05 32 034 | | 80 | 350+350 | 1,000 |
| P 05 32 043 | | 110 | 500+500 | 2,310 |



«Block fender»

«Block fender»

| Articolo - Item | €/pc. | ↑ mm. | kg. |
|-----------------|-------|-------------|-------|
| P 15 12 100 | | 1000x120x70 | 1,800 |



Protezione pontili in Pvc bianco gonfiabile

Fissaggio tramite viti attraverso gli occhi già predisposti o fascette, sfruttando gli incavi del pontile.

White Pvc inflatable fenders for wharfs

Fitting with bolts and screws through made-ready eyelets, or can be mounted with strips into already existing hollows.

| Articolo - Item | €/pc. | Length mm. | Width mm. | H cm. | kg. |
|-----------------|-------|------------|-----------|-------|-------|
| P 15 27 027 | | 885 | 270 | 270 | 6,000 |

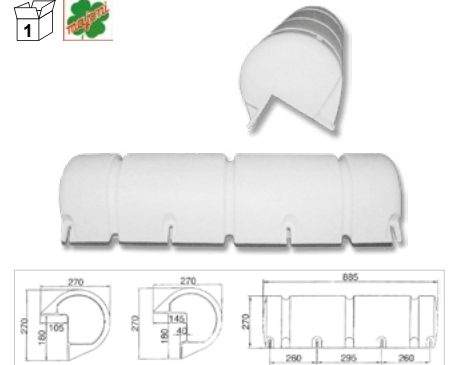

KIT PORTAPARABORDI | FENDER BASKET KIT

Morsetti in plastica per attaccare i cestelli alla battagliola **Plastic clamps for fastening of fender baskets**

| Articolo - Item | €/pc. | per tubo-for pipe Ø mm. | kg. |
|-----------------|-------|----------------------------|-------|
| P 07 22 030 | | 22-30 | 0,060 |

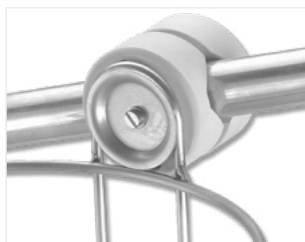

AISI 316

Morsetti Aisi 316 per attaccare i cestelli alla battagliola **Aisi 316 clamps for fastening of fender baskets**

| Articolo - Item | €/pc. | per tubo-for pipe Ø mm. | kg. |
|-----------------|-------|----------------------------|-------|
| P 06 30 000 | | 30 | 0,200 |
| P 06 35 000 | | 35 | 0,200 |
| P 06 50 000 | | 50x28 | 0,250 |



AISI 316

Morsetti per unire i cestelli porta parabordi **Fastening clamps to connect fender baskets**

| Articolo - Item | €/pc. | €/Box | mm. | kg. |
|-----------------|-------|-------|-------|-------|
| P 07 25 025 | | | 25x25 | 0,030 |

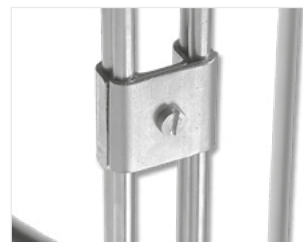

COME COMPORRE IL «FENDY SYSTEM»
ASSEMBLING YOUR «FENDY SYSTEM»

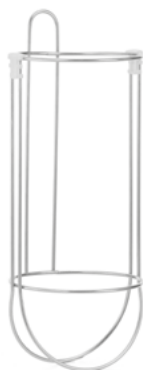

AISI 316

Cestelli porta parabordi Aisi 316

Privi di morsetti di fissaggio.

| Articolo - Item | €/pc. |
|-----------------|-------|
| P 06 32 170 | |
| P 06 32 180 | |
| P 06 32 185 | |
| P 06 32 215 | |
| P 06 32 230 | |
| P 06 42 250 | |
| P 06 42 305 | |



I cestelli sono forniti completi dei coprigiunti art. P0760200.
The baskets are supplied with joint covers art. P0760200.

Aisi 316 Fender baskets

Supplied without fastening clamps.

| mm. | kg. |
|---------------|-------|
| Ø 170 x H 405 | 0,600 |
| Ø 180 x H 430 | 0,620 |
| Ø 195 x H 433 | 0,650 |
| Ø 215 x H 443 | 0,700 |
| Ø 230 x H 450 | 0,730 |
| Ø 250 x H 560 | 0,930 |
| Ø 305 x H 588 | 0,950 |

SCHEMA DI ADATTABILITÀ | ADAPTABILITY TABLE

I portaparabordi «Fendy System» possono essere abbinati a 2 o 3 cestelli sullo stesso pulpito e sono adatti a tutti i parabordi in commercio come sotto indicato:

«Fendy System» fenders could be attached 2 or 3 together on the same pulpit and fit the following fenders:

| Art. Aisi 316 | P 06 32 170 | P 06 32 185 | P 06 32 215 | P 06 32 230 | P 06 42 250 | P 06 42 305 |
|---------------------------|--------------------------------|-------------------|-------------------|-----------------------------|--------------|---------------------------|
| Per parabordi-For fenders | 170 x 405 mm | 195 x 433 mm | 215 x 443 mm | 230 x 450 mm | 250 x 560 mm | 305 x 588 mm |
| Anchor Marine | 93081-93082 | 93091-93092-93493 | 93451-93452-93494 | 93101-93102-93495 | 93453-93454 | 93361-93362 |
| Majoni | SF2-HF2 | SF2A-CF3 | SF2 | | SF4-HF4 | SF5-HF5 |
| Plastimo | 1545 - 1558 | | 2056 2068 | | 2381 | 2563 |
| Polyform | G-3 HTM-1 - F-1 | F-1 G-4 | F-02 | G-5 - HTM-2 F-2 - F-3 - F-4 | F-3 F-4 | G-6 - HTM-3 F-5 - F-6 |
| Scan Marine | 622 FA623 | | FA82 FA827 | FA922-FA927-FA935 | FA1025 | FA1232 |
| Sowester Fenders | 30423 - 30424 30413 - 30414 | 30425 - 30426 | 30427 - 30428 | | | |
| Star Fenders | SCF2W SCF2W/BL | | SCF3W SCF3W/BL | | | SCF4W - SCF5W SCF4W/BL |
| Trem | | | | P 08 22 063 | | |
| Trem | | | | | | |
| Castro | | | | | | |
| Kg. Fender | | | | | | |



AISI 316

Kit cestelli porta parabordi Aisi316

Kit completo di 2 cestelli , 2 morsetti P0722030 e 2 morsetti P0725025.





Aisi 316 fender basket kit

Kit composed by 2 fender baskets , 2 clamps P0722030 and 2 clamps P0725025.

| Articolo - Item | €/kit | ↑ mm. | Cestelli-Baskets | kg. |
|-----------------|-------|-------------|------------------|-------|
| P 06 02 195 | | Ø 195xH 433 | P 06 32 185 | 1,400 |
| P 06 02 215 | | Ø 215xH 443 | P 06 32 215 | 1,500 |
| P 06 02 230 | | Ø 230xH 450 | P 06 32 230 | 1,600 |
| P 06 02 250 | | Ø 250xH 560 | P 06 42 250 | 2,000 |



COMPOSTO DA KIT WITH

| | | | |
|---|---|---|---|
|  |  |  |  |
| P0760200 4x | P0725025 2x (pag. 140) | P0722030 2x (pag. 140) | BASKETS 2x (pag. 140) |

Portaparabordi reclinabile adatto per contenere 2 parabordi

Portaparabordi modello semplificato, fabbricati in trafilata di acciaio inox lucidato. Provvisti di speciale attacco per consentire il fissaggio su battagliole o candelieri dritti o inclinati oppure a parete.

Foldable fender basket for 2 fenders

Manufactured in Aisi 316 stainless steel wire. Supplied with stainless steel plate with some holes for adjusting on all models of rails both right or inclined.

| Articolo - Item | €/pc. | Mod. | Per parabordi For fenders Ø max. cm. | kg. |
|-----------------|-------|-----------|--------------------------------------|-------|
| P 07 05 510 | | F1-F02-G4 | 19 | 0,450 |
| P 07 05 630 | | F2-F3 | 23 | 0,480 |

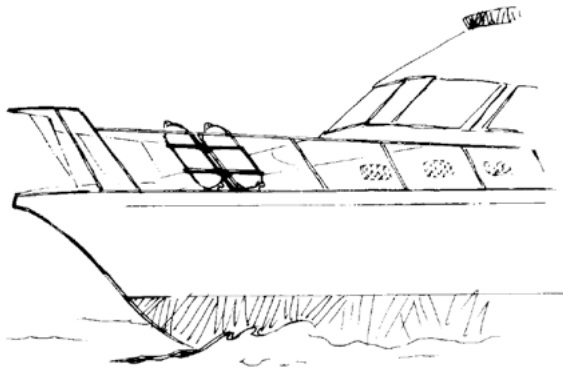

Portaparabordi reclinabile adatto per contenere 3 parabordi

Portaparabordi modello semplificato, fabbricati in trafilata di acciaio inox lucidato. Provvisti di speciale attacco per consentire il fissaggio su battagliole o candelieri dritti o inclinati oppure a parete.

Foldable fender basket for 3 fenders

Manufactured in Aisi 316 stainless steel wire. Supplied with stainless steel plate with some holes for adjusting on all models of rails both right or inclined.

| Articolo - Item | €/pc. | Mod. | Per parabordi For fenders Ø max. cm. | kg. |
|-----------------|-------|-----------|--------------------------------------|-------|
| P 07 03 500 | | F1-F02-G4 | 19 | 0,500 |
| P 07 03 580 | | F2-F3 | 23 | 0,580 |

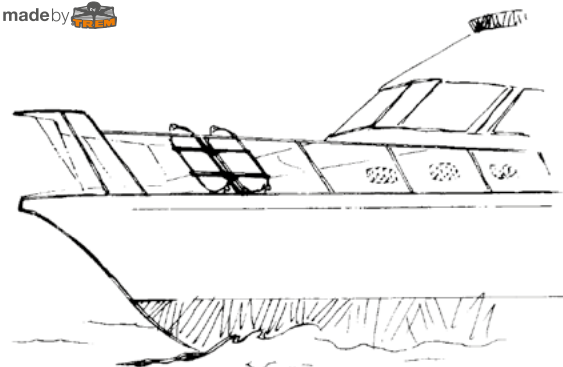

OLIVETTE E GALLEGGIANTI | MARKER FLOATS & BUOY ACCESSORIES

Olivette per delimitazione corsie e spiagge

Fabbricate in polipropilene soffiato e riempite di poliuretano espanso.

Marker float suitable for fences or run enclosures

Manufactured in plastic material.

| Articolo - Item | €/pc. | €/box | Colore Colour | Ø mm. | H mm. | Foro-Hole Ø mm. | kg. |
|-----------------|-------|-------|---------------|-------|-------|-----------------|-------|
| N 18 74 085 | | | □ | 85 | 50 | 20 | 0,050 |



Olivetta bicolore per delimitazione corsie e corridoi di navigazione

Fabbricata in materia plastica rossa e bianca.

Two-colours marker float for fences or navigation lines

Manufactured in white and red plastic material.

| Articolo - Item | €/pc. | Per cima-For line Ø mm. | Ø mm. | kg. |
|-----------------|-------|-------------------------|-------|-------|
| N 18 60 000 | | 6 - 8 - 10 | 60 | 0,070 |



Galleggianti per delimitazione corsie

In materia plastica, indicati anche come galleggianti per sci nautico.

Marker float suitable for run enclosures

Manufactured in plastic material. Also suitable for water ski.

| Articolo - Item | €/pc. | €/box | Colore Colour | Ø esterno outer Ø mm. | Foro-Hole Ø mm. | kg. |
|-----------------|-------|-------|---------------|-----------------------|-----------------|-------|
| N 18 74 030 | | | □ | 75 | 13 | 0,050 |
| N 18 00 030 | | | ■ | 75 | 13 | 0,050 |



Galleggiante per segnalazione corsie

In materia plastica soffiata, provvista di foro passante Ø 20 mm.

Marker float for navigation lines

Manufactured in plastic material. Fitted with central hole Ø 20 mm.

| Articolo - Item | €/pc. | Colore Colour | Lt. | Ø mm. | H mm. | kg. |
|-----------------|-------|---------------|-----|-------|-------|-------|
| P 11 17 070 | | ■ | 2 | 170 | 145 | 0,300 |
| P 11 17 077 | | ■ | 2 | 170 | 145 | 0,300 |
| P 11 17 074 | | □ | 2 | 170 | 145 | 0,300 |
| P 11 26 070 | | ■ | 9 | 260 | 200 | 0,400 |
| P 11 26 077 | | ■ | 9 | 260 | 200 | 0,400 |
| P 11 26 074 | | □ | 9 | 260 | 200 | 0,400 |



BOE E GAVITELLI | MOORING BUOYS

Boa a pera per segnalazioni e ormeggio

In materia plastica soffiata, munita di linea di galleggiamento.

Mooring buoy

Manufactured in plastic material. Suitable for signalling and mooring.

| Articolo - Item | €/pc. | Colore Colour | Lt. | Ø mm. | kg. |
|-----------------|-------|---------------|-----|-------|-------|
| P 11 25 001 | | ■ | 8 | 250 | 0,800 |
| P 11 25 002 | | ■ | 8 | 250 | 0,800 |
| P 11 25 003 | | □ | 8 | 250 | 0,800 |



Boe per segnalazioni e ormeggio

In materia plastica soffiata.

Mooring buoys

Manufactured in plastic material.

| Articolo - Item | €/pc. | Colore Colour | Ø mm. | Foro-Hole Ø mm. | kg. |
|-----------------|-------|---------------|-------|-----------------|-------|
| P 11 14 075 | | ■ | 210 | 14,5 | 0,640 |
| P 11 14 070 | | ■ | 240 | 16 | 1,080 |



Boa biconica «Gavitello»

Fabbricata in materia plastica soffiata.

Biconical buoy «Gavitello»

Manufactured in plastic material.

| Articolo - Item | €/pc. | Colore Colour | Lt. | mm. | kg. |
|-----------------|-------|---------------|-----|----------|-------|
| P 10 09 060 | | ■ | 9 | 270x600 | 1,200 |
| P 10 15 080 | | ■ | 15 | 320x800 | 1,400 |
| P 10 55 103 | | ■ | 55 | 500x1030 | 1,800 |





FANALI DI NAVIGAZIONE A LED IPX7 | LED NAVIGATION LIGHTS IPX7

PRO LED



COLREG 72

ABYC A16

CEVNI

RINA 20m



6-32V



LUCI DI NAVIGAZIONE | NAVIGATION LIGHTS



Fanale di fonda a LED «Gemini 360°»

Fanale di via a led predisposto per il fissaggio su piano o su asta tramite la basetta art. L3920050 e L3920074. Corpo e lenti in policarbonato.

- Dimensioni: Ø 60 mm. - H 80 mm.
- Alimentazione 9-32V.
- Potenza 2,0W.
- Consumo 0,1A.

LED all round anchor light «Gemini 360°»

Flat or pole-mounting LED navigation light. Fitting by base art. L3920050 and L3920074. Body and lens manufactured in Polycarbonate.

- Size: Ø 60 mm. - H 80 mm.
- Voltage 9-32V.
- Power 2,0W.
- Consumption 0,1A.

| Articolo - Item | €/pc. | Articolo - Item | €/pc. | Descrizione Description | Per barche For boats |
|-----------------|-------|-----------------|-------|-------------------------|----------------------|
| L 80 00 361 | | L 74 00 361 | | 360° Fonda Anchor | <20 |



SUGGESTED ITEM



OMOLOGATI



PATENTED

Fanale a LED «Gemini 360°»

Fanale a LED 360° applicabile su tutte le aste TR.EM. rimuovendo il vecchio fanale a lampadina. Corpo e lenti in policarbonato.

- Dimensioni: Ø 60 mm. - H 60 mm.
- Alimentazione 9-32V.
- Potenza 2,0W.
- Consumo 0,1A.

LED all round light «Gemini 360°»

LED 360° all round light suitable for all TR.EM. pole lights by replacing the old bulb lamp. Body and lens manufactured in Polycarbonate.

- Size: Ø 60 mm. - H 60 mm.
- Voltage 9-32V.
- Power 2,0W.
- Consumption 0,1A.

| Articolo - Item | €/pc. | Articolo - Item | €/pc. | Descrizione Description | Per barche For boats |
|-----------------|-------|-----------------|-------|-------------------------|----------------------|
| L 80 00 360 | | L 74 00 360 | | 360° | <20 |



OMOLOGATI



Fanale di fonda a LED «Gemini 360°»

Fanale di via a LED. Corpo e lenti in policarbonato.

- Dimensioni: Ø 60 mm. - H 110 mm.
- Alimentazione 9-32V.
- Potenza 2,0W.
- Consumo 0,1A.

LED all round anchor light «Gemini 360°»

LED navigation light. Body and lens manufactured in Polycarbonate.

- Size: Ø 60 mm. - H 110 mm.
- Voltage 9-32V.
- Power 2,0W.
- Consumption 0,1A.

| Articolo - Item | €/pc. | Articolo - Item | €/pc. | H mm. | Descrizione Description | Per barche For boats |
|-----------------|-------|-----------------|-------|-------|-------------------------|----------------------|
| L 80 74 360 | | L 74 74 360 | | 90 | 360° Fonda Anchor | <20 |



OMOLOGATI



AREA DI MONTAGGIO FIXING AREA

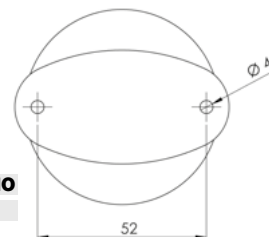

Asta fanale a LED retrattile «Gemini 360°»

Fanale a LED 360°. Asta Aisi 316. Corpo e lenti in policarbonato.

- Alimentazione 9-32V.
- Potenza 2,0W.
- Consumo 0,1A.

LED retractable pole light «Gemini 360°»

360° LED navigation light. Aisi 316 pole. Body and lens manufactured in Polycarbonate.

- Voltage 9-32V.
- Power 2,0W.
- Consumption 0,1A.

| Articolo - Item | €/pc. | Articolo - Item | €/pc. | H mm. | Descrizione Description | Per barche For boats |
|-----------------|-------|-----------------|-------|-------|-----------------------------|----------------------|
| L 80 01 360 | | L 74 01 360 | | 600 | 360° Retrattile Retractable | <20 |
| L 80 01 310 | | L 74 01 310 | | 1000 | | |



OMOLOGATI



Asta fanale a LED abbattibile
«Gemini 360°»

Fanale di via a LED 360°. Asta Aisi 316.
Corpo e lenti in policarbonato.
● Alimentazione 9-32V.
● Potenza 2,0W.
● Consumo 0,1A.

LED folding pole light
«Gemini 360°»

360° LED navigation light. Aisi 316 pole.
Body and lens manufactured in Polycarbonate.
● Voltage 9-32V.
● Power 2,0W.
● Consumption 0,1A.

| Articolo - Item | Articolo - Item | H mm. | Descrizione | Per barche |
|-----------------|-----------------|-------|-------------|-------------|
| €/pc. | €/pc. | | Description | For boats |
| L 80 01 230 | L 74 01 230 | 230 | | |
| L 80 01 610 | L 74 01 610 | 600 | 360° | Abbattibile |
| L 80 01 010 | L 74 01 010 | 1000 | | Folding <20 |



OMOLOGATI



Asta fanale a LED estraibile
«Gemini 360°»

Fanale di via a LED 360°. Asta Aisi 316.
Corpo e lenti in policarbonato.
● Alimentazione 9-32V.
● Potenza 2,0W.
● Consumo 0,1A.

LED pull-out pole light
«Gemini 360°»

360° LED navigation light. Aisi 316 pole.
Body and lens manufactured in Polycarbonate.
● Voltage 9-32V.
● Power 2,0W.
● Consumption 0,1A.

| Articolo - Item | Articolo - Item | H mm. | Descrizione | Per barche |
|-----------------|-----------------|-------|-------------|--------------|
| €/pc. | €/pc. | | Description | For boats |
| L 80 01 530 | L 74 01 530 | 600 | | |
| L 80 01 510 | L 74 01 510 | 1000 | 360° | Estraibile |
| | | | | Pull-out <20 |



OMOLOGATI



Asta fanale a LED attacco a parete
«Gemini 360°»

Fanale a LED 360°. Asta Aisi 316.
Corpo e lenti in policarbonato.
● Alimentazione 9-32V.
● Potenza 2,0W.
● Consumo 0,1A.

LED wall-mounting pole light
«Gemini 360°»

360° LED navigation light. Aisi 316 pole.
Body and lens manufactured in Polycarbonate.
● Voltage 9-32V.
● Power 2,0W.
● Consumption 0,1A.

| Articolo - Item | Articolo - Item | H mm. | Descrizione | Per barche |
|-----------------|-----------------|-------|-------------|--------------|
| €/pc. | €/pc. | | Description | For boats |
| L 80 01 100 | L 74 01 100 | 1000 | 360° | baionetta |
| | | | | A parete <20 |



COMPLETO DI-COMLETE WITH



OMOLOGATI



Asta fanale a LED attacco in piano
«Gemini 360°»

Fanale a LED 360°. Asta Aisi 316.
Corpo e lenti in policarbonato.
● Alimentazione 9-32V.
● Potenza 2,0W.
● Consumo 0,1A.

LED flat-mounting pole light
«Gemini 360°»

360° LED navigation light. Aisi 316 pole.
Body and lens manufactured in Polycarbonate.
● Voltage 9-32V.
● Power 2,0W.
● Consumption 0,1A.

| Articolo - Item | Articolo - Item | H mm. | Descrizione | Per barche |
|-----------------|-----------------|-------|-------------|--------------|
| €/pc. | €/pc. | | Description | For boats |
| L 80 00 100 | L 74 00 100 | 1000 | 360° | baionetta |
| | | | | In piano <20 |



COMPLETO DI-COMLETE WITH



OMOLOGATI



DISEGNO TECNICO-TECHNICAL DRAWING

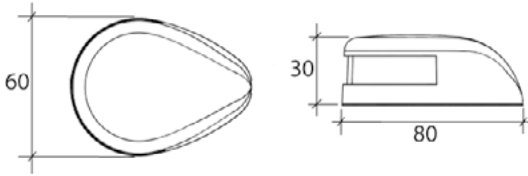

**AREA DI MONTAGGIO
FIXING AREA**

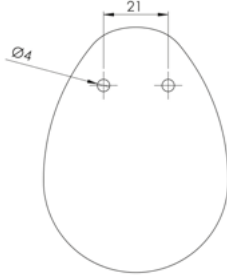

OMOLOGATI



Serie «GEMINI LED»

Lenti in policarbonato. Montaggio in piano.
Completati di circuito a led stagno.
● Alimentazione 9-32V.
● Potenza 1,5W.
● Consumo 0,1A.

«GEMINI LED» Navigation lights

Lens in Polycarbonate. Flat-mounting.
Complete with waterproof LED circuit board.
● Voltage 9-32V.
● Power 1,5W.
● Consumption 0,1A.

| Articolo - Item | Plastic | €/pc. | Articolo - Item | Plastic | €/pc. | Descrizione Description | Per barche For boats |
|-----------------|---------|-------|-----------------|---------|-------|-------------------------|----------------------|
| L 74 80 530 | | | L 74 74 530 | | | Sinistra Port | <12 |
| L 74 80 550 | | | L 74 74 550 | | | Dritta Starboard | <12 |
| L 74 80 610 | | | L 74 74 610 | | | Combi | <12 |



DISEGNO TECNICO-TECHNICAL DRAWING

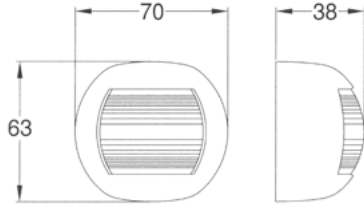

**AREA DI MONTAGGIO
FIXING AREA**

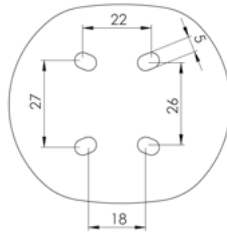

SUGGESTED ITEM



Serie «ORSA PRO LED»

Lenti in policarbonato. Montaggio a parete.
Completati di circuito a led stagno.
● Alimentazione 9-32V.
● Potenza 2,0W.
● Consumo 0,1A.

Series «ORSA PRO LED»

Lens in Polycarbonate. Wall-mounting.
Complete with waterproof LED circuit board.
● Voltage 9-32V.
● Power 2,0W.
● Consumption 0,1A.

| Articolo - Item | €/pc. | Articolo - Item | €/pc. | Articolo - Item Aisi 316 | €/pc. | Descrizione Description | Per barche For boats |
|-----------------|-------|-----------------|-------|--------------------------|-------|-------------------------|----------------------|
| L 76 80 530 | | L 76 74 530 | | L 76 32 530 | | Sinistra Port | <20 |
| L 76 80 550 | | L 76 74 550 | | L 76 32 550 | | Dritta Starboard | <20 |
| L 76 80 560 | | L 76 74 560 | | L 76 32 560 | | Prua Bow | <20 |
| L 76 80 580 | | L 76 74 580 | | L 76 32 580 | | Poppa Stern | <20 |



AISI 316

OMOLOGATI



KIT LUCI DI NAVIGAZIONE | NAVIGATION KIT



Serie 3 fanali «ORSA LED»

Composta da:
112,5° Rosso, 112,5° Verde, 135° Bianco.

Set of 3 navigation lights «ORSA LED»

Set complete with:
112,5° Red, 112,5° Green, 135° White.

| Articolo - Item | €/kit | Corpo-Body |
|-----------------|-------|----------------------|
| L 76 74 003 | | <input type="text"/> |
| L 76 80 003 | | <input type="text"/> |



EASY LED



ABYC
A16

COLREG
72

RINA
12-20m





Fanale di fonda a LED con bassetta «EASY LED»

Lenti in policarbonato.
Completati di lampadine LED e alogena.
• Alimentazione 12V.
• Potenza 2,0W.
• Consumo 0,1A.

LED anchor light with base «EASY LED»

Lens in Polycarbonate.
Supplied with LED and halogen bulbs.
• Voltage 12V.
• Power 2,0W.
• Consumption 0,1A.

| Articolo - Item | €/pc. | Articolo - Item | €/pc. | Articolo - Item | €/pc. | H mm. | Descrizione Description | Per barche For boats |
|-----------------|-------|-----------------|-------|-----------------|-------|-------|-------------------------|----------------------|
| L 38 74 363 | | L 41 74 363 | | L 42 74 363 | | 110 | 360° Fonda Anchor | <20 |

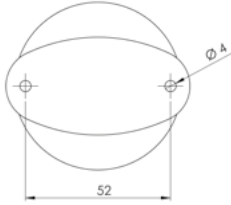

OMOLOGATI



COMPLETO DI-COMLETE WITH



Art. L0812010 (pag. 193) Art. L4400200 (pag. 195) Art. L3900074 (pag. 155)



Fanale 360° di fonda a LED «EASY LED»

Lenti in policarbonato.
Completati di lampadine LED e alogena.
• Alimentazione 12V.
• Potenza 2,0W.
• Consumo 0,1A.

LED 360° anchor light «EASY LED»

Lens in Polycarbonate.
Supplied with LED and halogen bulbs.
• Voltage 12V.
• Power 2,0W.
• Consumption 0,1A.

| Articolo - Item | €/pc. | Articolo - Item | €/pc. | Articolo - Item | €/pc. | H mm. | Descrizione Description | Per barche For boats |
|-----------------|-------|-----------------|-------|-----------------|-------|-------|-------------------------|----------------------|
| L 39 14 363 | | L 41 14 363 | | L 42 14 363 | | 60 | 360° Fonda Anchor | <20 |

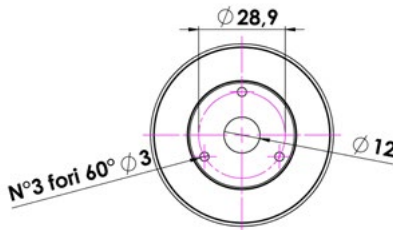

OMOLOGATI



COMPLETO DI-COMLETE WITH



Art. L0812010 (pag. 193) Art. L4400200 (pag. 195) Art. L3900074 (pag. 155)



Asta fanale 360° a LED estraibile a parete «EASY LED»

Corpo ABS. Lenti in policarbonato. Asta Aisi 316.
Completati di lampadine LED e alogena.
• Alimentazione 12V.
• Potenza 2,0W.
• Consumo 0,1A.

LED 360° pull-out wall-mounting anchor light «EASY LED»

ABS body. Lens in Polycarbonate. Aisi 316 pole.
Supplied with LED and halogen bulbs.
• Voltage 12V.
• Power 2,0W.
• Consumption 0,1A.

| Articolo - Item | €/pc. | Articolo - Item | €/pc. | H mm. | Descrizione Description | Per barche For boats |
|-----------------|-------|-----------------|-------|-------|---|----------------------|
| L 38 01 103 | | L 41 01 103 | | 1000 | 360° Estraibile a parete Pull-out wall-mounting | <20 |



OMOLOGATI



COMPLETO DI-COMLETE WITH



Art. L0812010 (pag. 193) Art. L4400200 (pag. 195) Art. L3801102 (pag. 155) Art. L4101102 (pag. 155) Art. L3900074 (pag. 155)



Asta fanale 360° a LED estraibile in piano «EASY LED»

Corpo ABS. Lenti in policarbonato. Asta Aisi 316.
Completati di lampadine LED e alogena.
• Alimentazione 12V.
• Potenza 2,0W.
• Consumo 0,1A.

LED 360° pull-out flat-mounting anchor light «EASY LED»

ABS body. Lens in Polycarbonate. Aisi 316 pole.
Supplied with LED and halogen bulbs.
• Voltage 12V.
• Power 2,0W.
• Consumption 0,1A.

| Articolo - Item | €/pc. | Articolo - Item | €/pc. | H mm. | Descrizione Description | Per barche For boats |
|-----------------|-------|-----------------|-------|-------|---|----------------------|
| L 38 00 103 | | L 41 00 103 | | 1000 | 360° Estraibile in piano Pull-out flat-mounting | <20 |



OMOLOGATI



COMPLETO DI-COMLETE WITH



Art. L0812010 (pag. 193) Art. L4400200 (pag. 195) Art. L3801102 (pag. 155) Art. L4101102 (pag. 155) Art. L3900074 (pag. 155)

Asta fanale a LED retrattile «EASY LED»

Corpo ABS. Lenti in policarbonato. Asta Aisi 316. Completa di lampadine LED e alogena.
 • Alimentazione 12V.
 • Potenza 2,0W.
 • Consumo 0,1A.

LED retractable pole light «EASY LED»

ABS body. Lens in Polycarbonate. Aisi 316 pole. Supplied with LED and halogen bulbs.
 • Voltage 12V.
 • Power 2,0W.
 • Consumption 0,1A.

| Articolo - Item | €/pc. | Articolo - Item | €/pc. | H mm. | Descrizione Description | Per barche For boats |
|-----------------|-------|-----------------|-------|-------|-----------------------------|----------------------|
| L 38 01 363 | | L 41 01 363 | | 600 | 360° Retrattile Retractable | <20 |
| - | | L 41 01 313 | | 1000 | | |



COMPLETO DI-COMLETE WITH



OMOLOGATI



Asta fanale a LED estraibile «EASY LED»

Corpo ABS. Lenti in policarbonato. Asta Aisi 316. Completa di lampadine LED e alogena.
 • Alimentazione 12V.
 • Potenza 2,0W.
 • Consumo 0,1A.

LED pull-out pole light «EASY LED»

ABS body. Lens in Polycarbonate. Aisi 316 pole. Supplied with LED and halogen bulbs.
 • Voltage 12V.
 • Power 2,0W.
 • Consumption 0,1A.

| Articolo - Item | €/pc. | Articolo - Item | €/pc. | H mm. | Descrizione Description | Per barche For boats |
|-----------------|-------|-----------------|-------|-------|--------------------------|----------------------|
| L 38 01 533 | | L 41 01 533 | | 600 | 360° Estraibile Pull-out | <20 |
| L 38 01 513 | | - | | 1000 | | |



COMPLETO DI-COMLETE WITH



OMOLOGATI



Asta fanale a LED abbattibile «EASY LED»

Corpo ABS. Lenti in policarbonato. Asta Aisi 316. Completa di lampadine LED e alogena.
 • Alimentazione 12V.
 • Potenza 2,0W.
 • Consumo 0,1A.

LED folding pole light «EASY LED»

ABS body. Lens in Polycarbonate. Aisi 316 pole. Supplied with LED and halogen bulbs.
 • Voltage 12V.
 • Power 2,0W.
 • Consumption 0,1A.

| Articolo - Item | €/pc. | Articolo - Item | €/pc. | H mm. | Descrizione Description | Per barche For boats |
|-----------------|-------|-----------------|-------|-------|--------------------------|----------------------|
| L 38 01 233 | | L 41 01 233 | | 230 | 360° Abbattibile Folding | <20 |
| L 38 01 613 | | L 41 01 613 | | 600 | | |
| L 38 01 013 | | - | | 1000 | | |



COMPLETO DI-COMLETE WITH



OMOLOGATI



Serie «MINI STAR EASY LED»

Lenti in policarbonato. Montaggio a parete. Completi di lampadine LED e alogena.
 • Alimentazione 12V.
 • Potenza 1,0W.
 • Consumo 0,1A.

«MINI STAR EASY LED» lights

Lens in Polycarbonate. Wall-mounting. Supplied with LED and halogen bulbs.
 • Voltage 12V.
 • Power 1,0W.
 • Consumption 0,1A.

| Articolo - Item | €/pc. | Articolo - Item | €/pc. | Descrizione Description | Per barche For boats |
|-----------------|-------|-----------------|-------|-------------------------|----------------------|
| L 59 80 533 | | L 59 74 533 | | 360° Sinistra Port | <12 |
| L 59 80 553 | | L 59 74 553 | | 360° Dritta Starboard | <12 |
| L 59 80 563 | | L 59 74 563 | | 225° Prua Bow | <12 |
| L 59 80 583 | | L 59 74 583 | | 135° Poppa Stern | <12 |
| L 59 80 613 | | L 59 74 613 | | 225° Combi | <12 |



AREA DI MONTAGGIO FIXING AREA

DISEGNO TECNICO TECHNICAL DRAWING

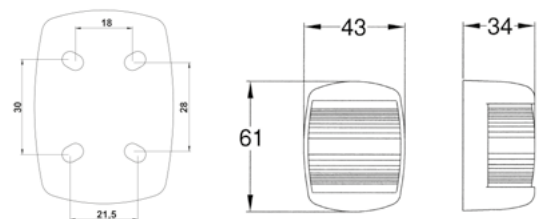

SUGGESTED ITEMS



COMPLETE WITH



OMOLOGATI



**AREA DI MONTAGGIO
FIXING AREA**

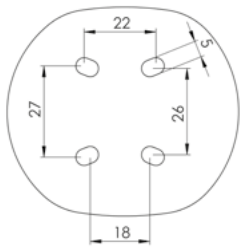

DISEGNO TECNICO-TECHNICAL DRAWING

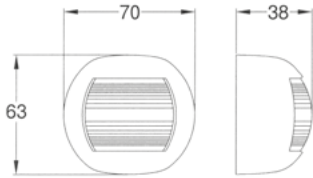

SUGGESTED ITEMS



COMPLETE WITH



OMOLOGATI



Serie «ORSA EASY LED»

Lenti in policarbonato. Montaggio a parete.
Completati di lampadine led e alogena.
• Alimentazione 12V.
• Potenza 1,0W.
• Consumo 0,1A.

«ORSA EASY LED» lights

Lens in Polycarbonate. Wall-mounting.
Supplied with LED and halogen bulbs.
• Voltage 12V.
• Power 1,0W.
• Consumption 0,1A.

| Articolo - Item | Articolo - Item | Articolo - Item | Descrizione | Per barche |
|-----------------|-----------------|-----------------|------------------|------------|
| €/pc. | €/pc. | Aisi 316 | Description | For boats |
| L 58 80 533 | L 58 74 533 | L 58 32 533 | Sinistra Port | <12 |
| L 58 80 553 | L 58 74 553 | L 58 32 553 | Dritta Starboard | <12 |
| L 58 80 563 | L 58 74 563 | L 58 32 563 | Prua Bow | <12 |
| L 58 80 583 | L 58 74 583 | L 58 32 583 | Poppa Stern | <12 |
| L 58 80 613 | L 58 74 613 | L 58 32 613 | Combi | <12 |

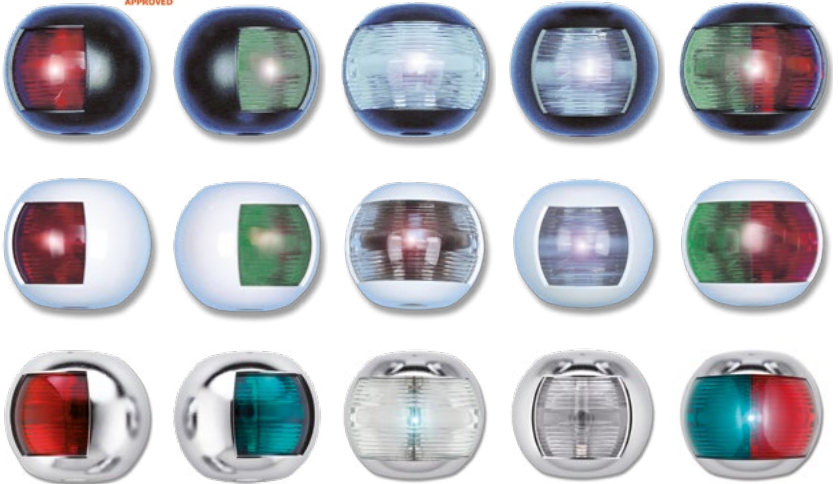

AISI 316

**AREA DI MONTAGGIO
FIXING AREA**

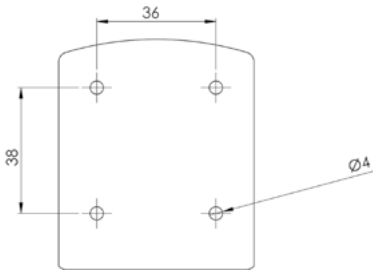

DISEGNO TECNICO-TECHNICAL DRAWING

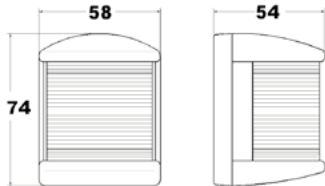

SUGGESTED ITEMS



COMPLETE WITH



OMOLOGATI



Serie «CROCE EASY LED»

Lenti in policarbonato. Montaggio a parete.
Completati di lampadine led e alogena.
• Alimentazione 12V.
• Potenza 1,0W.
• Consumo 0,1A.

«CROCE EASY LED» lights

Lens in Polycarbonate. Wall-mounting.
Supplied with LED and halogen bulbs.
• Voltage 12V.
• Power 1,0W.
• Consumption 0,1A.

| Articolo - Item | Articolo - Item | Descrizione | Per barche |
|-----------------|-----------------|------------------|------------|
| €/pc. | €/pc. | Description | For boats |
| L 36 80 533 | L 36 74 533 | Sinistra Port | <12 |
| L 36 80 553 | L 36 74 553 | Dritta Starboard | <12 |
| L 36 80 563 | L 36 74 563 | Prua Bow | <12 |
| L 36 80 583 | L 36 74 583 | Poppa Stern | <12 |
| L 36 80 613 | L 36 74 613 | Combi | <12 |



ABYC
A16

COLREG
72

RINA
12-20m





Fanale di fonda 360° alogeno con basetta

Lenti in policarbonato.
Completo di lampadina alogena.
• Alimentazione 12V.
• Potenza 10,0W.
• Consumo 1,0A.

Halogen 360° anchor light with base

Lens in Polycarbonate.
Supplied with halogen bulb.
• Voltage 12V.
• Power 10,0W.
• Consumption 1,0A.

| Articolo - Item | €/pc. | Articolo - Item | €/pc. | Articolo - Item | €/pc. | H mm. | Descrizione Description | Per barche For boats |
|-----------------|-------|-----------------|-------|-----------------|-------|-------|-------------------------|----------------------|
| L 38 74 360 | | L 41 74 360 | | L 42 74 360 | | 110 | 360° Fonda Anchor | <20 |

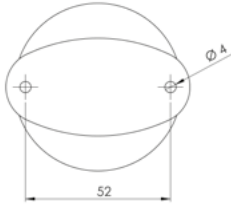

OMOLOGATI



COMPLETO DI-COMLETE WITH



SUGGESTED ITEM



Fanale di fonda 360° alogeno

Lenti in policarbonato.
Completo di lampadina alogena.
• Alimentazione 12V.
• Potenza 10,0W.
• Consumo 1,0A.

Halogen 360° anchor light

Lens in Polycarbonate.
Supplied with halogen bulb.
• Voltage 12V.
• Power 10,0W.
• Consumption 1,0A.

| Articolo - Item | €/pc. | Articolo - Item | €/pc. | Articolo - Item | €/pc. | H mm. | Descrizione Description | Per barche For boats |
|-----------------|-------|-----------------|-------|-----------------|-------|-------|-------------------------|----------------------|
| L 39 14 360 | | L 41 14 360 | | L 42 14 360 | | 60 | 360° Fonda Anchor | <20 |

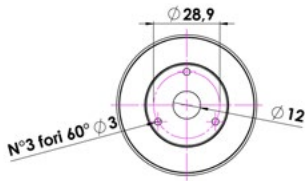

OMOLOGATI



COMPLETO DI-COMLETE WITH



SUGGESTED ITEM



Fanale Non Governo 360° alogeno

Lenti in policarbonato.
Completo di lampadina alogena.
• Alimentazione 12V.
• Potenza 10,0W.
• Consumo 1,0A.

Halogen 360° all round light

Lens in Polycarbonate.
Supplied with halogen bulb.
• Voltage 12V.
• Power 10,0W.
• Consumption 1,0A.

| Articolo - Item | €/pc. | Articolo - Item | €/pc. | Articolo - Item | €/pc. | H mm. | Descrizione Description | Per barche For boats |
|-----------------|-------|-----------------|-------|-----------------|-------|-------|-------------------------|----------------------|
| L 38 82 360 | | L 41 82 360 | | L 42 82 360 | | 110 | 360° Non Governo | <20 |

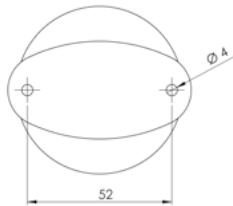

OMOLOGATI



COMPLETO DI-COMLETE WITH



SUGGESTED ITEM



Fanale di Non Governo 360° alogeno

Lenti in policarbonato.
Completo di lampadina alogena.
• Alimentazione 12V.
• Potenza 10,0W.
• Consumo 1,0A.

Halogen 360° all round light

Lens in Polycarbonate.
Supplied with halogen bulb.
• Voltage 12V.
• Power 10,0W.
• Consumption 1,0A.

| Articolo - Item | ABS €/pc. | Articolo - Item | ABS €/pc. | H mm. | Descrizione Description | Per barche For boats |
|-----------------|-----------|-----------------|-----------|-------|-------------------------|----------------------|
| L 39 84 360 | | L 41 84 360 | | 60 | 360° Non Governo | <20 |

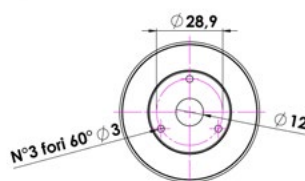

OMOLOGATI



COMPLETO DI-COMLETE WITH



SUGGESTED ITEM



Asta fanale 360° alogena estraibile a parete

Corpo ABS. Lenti in policarbonato. Asta Aisi 316.
Completa di lampadina alogena.
• Alimentazione 12V.
• Potenza 10,0W.
• Consumo 1,0A.

Halogen 360° pull-out wall-mounting pole light

ABS body. Lens in Polycarbonate. Aisi 316 pole.
Supplied with halogen bulb.
• Voltage 12V.
• Power 10,0W.
• Consumption 1,0A.

| Articolo - Item | €/pc. | Articolo - Item | €/pc. | H mm. | Descrizione Description | Per barche For boats |
|-----------------|-------|-----------------|-------|-------|-----------------------------|----------------------|
| L 38 01 100 | | L 41 01 100 | | 1000 | 360° Estraibile a parete | <20 |



COMPLETO DI-COMPLETE WITH



SUGGESTED ITEM



OMOLOGATI



Asta fanale 360° alogena estraibile in piano

Corpo ABS. Lenti in policarbonato. Asta Aisi 316.
Completa di lampadina alogena.
• Alimentazione 12V.
• Potenza 10,0W.
• Consumo 1,0A.

Halogen 360° pull-out flat-mounting pole light

ABS body. Lens in Polycarbonate. Aisi 316 pole.
Supplied with halogen bulb.
• Voltage 12V.
• Power 10,0W.
• Consumption 1,0A.

| Articolo - Item | €/pc. | Articolo - Item | €/pc. | H mm. | Descrizione Description | Per barche For boats |
|-----------------|-------|-----------------|-------|-------|-----------------------------|----------------------|
| L 38 00 100 | | L 41 00 100 | | 1000 | 360° Estraibile in piano | <20 |



COMPLETO DI-COMPLETE WITH



SUGGESTED ITEM



OMOLOGATI



Asta fanale 360° alogena estraibile a parete con fanale Combi 225°

Corpo ABS. Lenti in policarbonato. Asta Aisi 316.
Completa di lampadina led e alogena.
• Alimentazione 12V.
• Potenza 10,0W.+10W.
• Consumo 1,0A.

Halogen 360° pull-out wall-mounting pole light with Combi 225° light

ABS body. Lens in Polycarbonate. Aisi 316 pole.
Supplied with halogen bulb.
• Voltage 12V.
• Power 10,0W.+10,0W.
• Consumption 1,0A.

| Articolo - Item | €/pc. | Articolo - Item | €/pc. | H mm. | Descrizione Description | Per barche For boats |
|-----------------|-------|-----------------|-------|-------|------------------------------------|----------------------|
| L 38 01 101 | | L 41 01 101 | | 1000 | 360° + 225° Estraibile a parete | <20 |



COMPLETO DI-COMPLETE WITH



SUGGESTED ITEM



OMOLOGATI



Asta fanale 360° alogena estraibile in piano con fanale Combi 225°

Corpo ABS. Lenti in policarbonato. Asta Aisi 316.
Completa di lampadina led e alogena.
• Alimentazione 12V.
• Potenza 10,0W.+10W.
• Consumo 1,0A.

Halogen 360° pull-out flat-mounting pole light with Combi 225° light

ABS body. Lens in Polycarbonate. Aisi 316 pole.
Supplied with halogen bulb.
• Voltage 12V.
• Power 10,0W.+10,0W.
• Consumption 1,0A.

| Articolo - Item | €/pc. | Articolo - Item | €/pc. | H mm. | Descrizione Description | Per barche For boats |
|-----------------|-------|-----------------|-------|-------|------------------------------------|----------------------|
| L 38 00 101 | | L 41 00 101 | | 1000 | 360° + 225° Estraibile in piano | <20 |



COMPLETO DI-COMPLETE WITH



SUGGESTED ITEM



OMOLOGATI





Asta fanale alogena estraibile

Corpo ABS. Lenti in policarbonato. Asta Aisi 316.
Completa di lampadina alogena.
• Alimentazione 12V.
• Potenza 10W.
• Consumo 1,0A.
• Base 65x44 mm. x H 65 mm.

Halogen pull-out pole light

ABS body. Lens in Polycarbonate. Aisi 316 pole.
Supplied with halogen bulb.
• Voltage 12V.
• Power 10,0W.
• Consumption 1,0A.
• Base 65x44 mm. x H 65 mm.

| Articolo - Item | €/pc. | Articolo - Item | €/pc. | H mm. | Descrizione Description | Per barche For boats |
|-----------------|-------|-----------------|-------|-------|-----------------------------|----------------------|
| L 38 01 530 | | L 41 01 530 | | 600 | 360° Estraibile Pull-out | <20 |
| L 38 01 510 | | - | | 1000 | | |



COMPLETO DI-COMLETE WITH



SUGGESTED ITEM



OMOLOGATI



Asta fanale alogena abbattibile

Corpo ABS. Lenti in policarbonato. Asta Aisi 316.
Completa di lampadina alogena.
• Alimentazione 12V.
• Potenza 10W.
• Consumo 1,0A.
• Base 77x39 mm.

Halogen folding pole light

ABS body. Lens in Polycarbonate. Aisi 316 pole.
Supplied with halogen bulb.
• Voltage 12V.
• Power 10,0W.
• Consumption 1,0A.
• Base 77x39 mm.

| Articolo - Item | €/pc. | Articolo - Item | €/pc. | H mm. | Descrizione Description | Per barche For boats |
|-----------------|-------|-----------------|-------|-------|-----------------------------|----------------------|
| L 38 01 230 | | L 41 01 230 | | 230 | 360° Abbattibile Folding | <20 |
| L 38 01 610 | | L 41 01 610 | | 600 | | |
| L 38 01 010 | | - | | 1000 | | |



COMPLETO DI-COMLETE WITH



SUGGESTED ITEM



OMOLOGATI



Asta fanale alogena retrattile

Corpo ABS. Lenti in policarbonato. Asta Aisi 316.
Completa di lampadina alogena.
• Alimentazione 12V.
• Potenza 2,0W.
• Consumo 0,1A.
• Base 65x44 mm.

Halogen retractable pole light

ABS body. Lens in Polycarbonate. Aisi 316 pole.
Supplied with halogen bulb.
• Voltage 12V.
• Power 2,0W.
• Consumption 0,1A.
• Base 65x44 mm.

| Articolo - Item | €/pc. | Articolo - Item | €/pc. | H mm. | Descrizione Description | Per barche For boats |
|-----------------|-------|-----------------|-------|-------|--------------------------------|----------------------|
| L 38 01 360 | | L 41 01 360 | | 600 | 360° Retrattile Retractable | <20 |
| - | | L 41 01 310 | | 1000 | | |



COMPLETO DI-COMLETE WITH



SUGGESTED ITEM



OMOLOGATI



Asta fanale combinata

Altezza 200 mm.
Alimentazione 12V.
Consumo 2,5A.

Combi pole light

Height 200 mm.
Power 12v.
Consumption 2.5A.

| Articolo - Item | €/pc. | Colore corpo Body colour | Composta da fanali Composed of lights |
|-----------------|-------|-----------------------------|--|
| L 58 80 003 | | ■ | |
| L 58 74 003 | | □ | |



COMPLETO DI-COMLETE WITH



SUGGESTED ITEM



OMOLOGATI



Asta fanale 360°

Altezza 200 mm.
Alimentazione 12V.
Potenza 10W.
Consumo 1A.

360° pole light

Height 200 mm.
Voltage 12v.
Power 10W.
Consumption 1,0A.

| Articolo - Item | €/pc. | Colore corpo Body colour | Composta da fanali Composed of lights |
|-----------------|-------|-----------------------------|--|
| L 38 20 360 | | ■ | |
| L 41 20 360 | | □ | |



COMPLETO DI-COMLETE WITH



SUGGESTED ITEM



OMOLOGATI



Basetta per applicazione del fanale L3914360 e L4114360 su asta Ø 20 mm. - 28 mm.

Basetta in nylon completa di viti e indicata per tubo Ø 20/28 mm.

Base for mounting light L3914360 and L4114360 on rod Ø 20 mm. - 28 mm.

Manufactured in nylon, with screws, suitable for pipe Ø 20/28 mm.

| Articolo - Item | €/pc. | Tubi-Pipes Ø mm. | Colore-Colour | kg. |
|-----------------|-------|------------------|---------------|-------|
| L 39 20 050 | | 20-28 | ■ | 0,040 |
| L 39 20 074 | | 20-28 | □ | 0,040 |



Vetro di ricambio per fanali 360°

| Articolo - Item | €/pc. | Colore-Colour | kg. |
|-----------------|-------|---------------|-------|
| L 39 00 074 | | □ | 0,030 |
| L 39 00 082 | | ■ | 0,030 |



Spare glass for navigation lights 360°



Clips per fissaggio bandiere

Fabbricata in plastica.
Montaggio a clips.

Clips for flag fastening

Manufactured in plastic.
Clips mounting system.

| Articolo - Item | €/pair | Foro-Hole Ø mm. | kg. |
|-----------------|--------|-----------------|-------|
| L 08 45 018 | | 18 | 0,020 |



AISI 316

Attacchi di ricambio per aste fanale 360°

| Articolo - Item | €/pc. | Attacco Fitting | Colore corpo Body colour |
|-----------------|-------|--------------------|-----------------------------|
| L 38 00 102 | | Al piano-Flat | ■ |
| L 41 00 102 | | Al piano-Flat | □ |
| L 38 01 102 | | A parete-Wall | ■ |
| L 41 01 102 | | A parete-Wall | □ |



Spare connections for 360° light poles



**AREA DI MONTAGGIO
FIXING AREA**

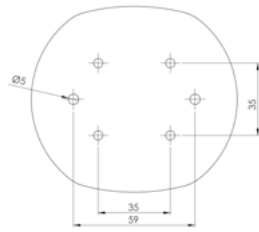

**DISEGNO TECNICO
TECHNICAL DRAWING**

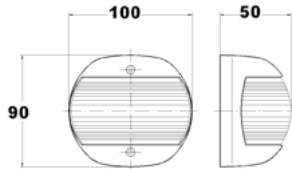

SUGGESTED ITEM



COMPLETE WITH



OMOLOGATI



Fanali alogeni «STELLA POLARE» 12V

Lenti in policarbonato.
Montaggio a parete e chiusura con viti inox.
Completati di lampadine 12V.
● Potenza 15 W.
● Consumo 1,0A.

«STELLA POLARE» halogen lights 12V

Lens in Polycarbonate.
Wall-mounting and fastening by stainless steel screws. Complete with 12V bulbs.
● Power 15 W.
● Consumption 1,0A.

| Articolo - Item | €/pc. | Articolo - Item | €/pc. | Articolo - Item Chromo | €/pc. | Descrizione Description | Per barche For boats |
|-----------------|-------|-----------------|-------|------------------------|-------|-------------------------|----------------------|
| L 57 80 530 | | L 57 74 530 | | L 57 79 530 | | Sinistra Port | <20 |
| L 57 80 550 | | L 57 74 550 | | L 57 79 550 | | Dritta Starboard | <20 |
| L 57 80 560 | | L 57 74 560 | | L 57 79 560 | | Prua Bow | <20 |
| L 57 80 580 | | L 57 74 580 | | L 57 79 580 | | Poppa Stern | <20 |
| L 57 80 610 | | L 57 74 610 | | L 57 79 610 | | Combi | <20 |



**CONFEZIONE BLISTER SINGOLO
BLISTER SINGOLAR PKG SHIPYARD**



**CONFEZIONE SFUSA CANTIERI
BULK PKG FOR SHIPYARD**



Fanali alogeni «STELLA POLARE» 12V

Lenti in policarbonato.
Montaggio a parete e chiusura con viti inox.
Completati di lampadine 12V.
● Potenza 15 W.
● Consumo 1,0A.

«STELLA POLARE» halogen lights 12V

Lens in Polycarbonate.
Wall-mounting and fastening by stainless steel screws. Complete with 12V bulbs.
● Power 15 W.
● Consumption 1,0A.

| Articolo - Item | €/pc. | €/box | Descrizione-Description | Per barche For boats |
|-----------------|-------|-------|-------------------------|----------------------|
| L 57 74 532 | | | Sinistra Port | <20 |
| L 57 74 552 | | | Dritta Starboard | <20 |



**AREA DI MONTAGGIO
FIXING AREA**

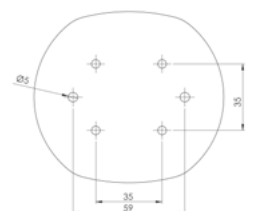

**DISEGNO TECNICO
TECHNICAL DRAWING**

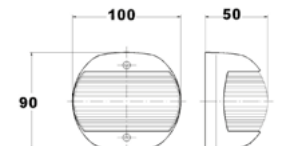

SUGGESTED ITEM



COMPLETE WITH



OMOLOGATI



Fanali alogeni «STELLA POLARE» 24V

Lenti in policarbonato.
Montaggio a parete e chiusura con viti inox.
Completati di lampadine 24V.
● Potenza 15W.
● Consumo 1A.
● Lumen

«STELLA POLARE» halogen lights 24V

Lens in Polycarbonate.
Wall-mounting and fastening by stainless steel screws. Complete with 24V bulbs.
● Power 15W.
● Consumption 1A.
● Lumen





| Articolo - Item | €/pc. | Articolo - Item | €/pc. | Descrizione Description | Per barche For boats |
|-----------------|-------|-----------------|-------|-------------------------|----------------------|
| L 60 80 530 | | L 60 74 530 | | Sinistra Port | <20 |
| L 60 80 550 | | L 60 74 550 | | Dritta Starboard | <20 |
| L 60 80 560 | | L 60 74 560 | | Prua Bow | <20 |
| L 60 80 580 | | L 60 74 580 | | Poppa Stern | <20 |
| L 60 80 610 | | L 60 74 610 | | Combi | <20 |



Fanali di via alogeni «ORSA MINORE» 12V «ORSA MINORE» halogen lights 12V

Lenti in policarbonato.
Montaggio a parete e chiusura a scatto.
Completi di lampadine 12V.
● Potenza 10W.
● Consumo 1,0A.

Lens in Polycarbonate.
Wall-mounting and fastening by stainless steel screws.
Complete with 12V bulbs.
● Power 10W.
● Consumption 1,0A.

| Articolo - Item | €/pc. | Articolo - Item | €/pc. | Articolo - Item Aisi 316 | €/pc. | Descrizione Description | Per barche For boats |
|-----------------|-------|-----------------|-------|--------------------------|-------|--|----------------------|
| L 58 80 530 | | L 58 74 530 | | L 58 32 530 | |  Sinistra Port | <12 |
| L 58 80 550 | | L 58 74 550 | | L 58 32 550 | |  Dritta Starboard | <12 |
| L 58 80 560 | | L 58 74 560 | | L 58 32 560 | |  Prua Bow | <12 |
| L 58 80 580 | | L 58 74 580 | | L 58 32 580 | |  Poppa Stern | <12 |
| L 58 80 610 | | L 58 74 610 | | L 58 32 610 | |  Combi | <12 |

**AREA DI MONTAGGIO
FIXING AREA**

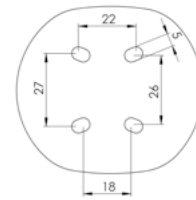

**DISEGNO TECNICO
TECHNICAL DRAWING**

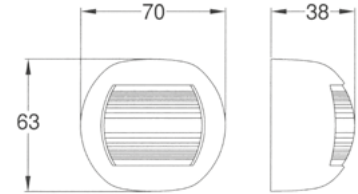

**CONFEZIONE BLISTER SINGOLO
BLISTER SINGULAR PKG SHIPYARD**







COMPLETE WITH SUGGESTED ITEM



OMOLOGATI



Fanali di via alogeni «ORSA MINORE» 12V «ORSA MINORE» halogen lights 12V

| Articolo - Item Bulk 12 pcs. | €/pc. | €/box | Articolo - Item Cablati Bulk 12 pcs. | €/pc. | €/box | Descrizione Description | Per barche For boats |
|------------------------------|-------|-------|--------------------------------------|-------|-------|--|----------------------|
| L 58 74 532 | | | L 58 74 531C | | |  Sinistra Port | <12 |
| L 58 74 552 | | | L 58 74 551C | | |  Dritta Starboard | <12 |
| L 58 74 562 | | - | - | | |  Prua Bow | <12 |
| L 58 74 582 | | - | - | | |  Poppa Stern | <12 |
| L 58 74 612 | | - | - | | |  Combi | <12 |

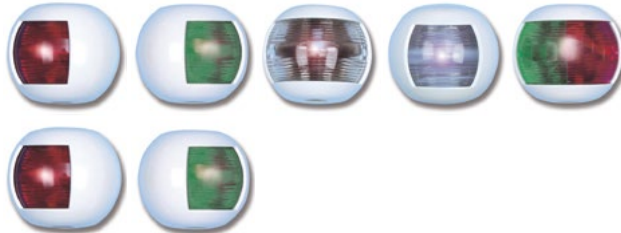

**CONFEZIONE SFUSA CANTIERI
BULK PKG FOR SHIPYARD**





NAVIGATION KIT

Serie 4 fanali «ORSA MINORE»

Composta da:
112,5° Rosso, 112,5° Verde, 225° Bianco, 135° Bianco.

Set of 4 navigation lights «ORSA MINORE»

Set complete with:
112,5° Red, 112,5° Green, 225° White, 135° White.

| Articolo - Item | €/kit | Corpo-Body |
|-----------------|-------|---|
| L 58 74 004 | |  |
| L 58 80 004 | |  |



**AREA DI MONTAGGIO
FIXING AREA**

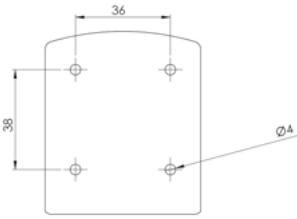

**DISEGNO TECNICO
TECHNICAL DRAWING**

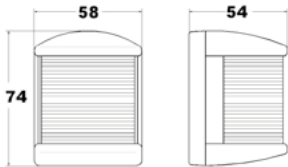

Fanali di via alogeni «CROCE DEL SUD» 12V

Lenti in policarbonato. Montaggio a parete e chiusura a scatto.
Completati di lampadine 12V.
● Potenza 10W. ● Consumo 1A.

«CROCE DEL SUD» halogen lights 12V

Lens in Polycarbonate. Wall-mounting and snap closure system.
Complete with 12V bulbs.
● Power 10W. ● Consumption 1A.

| Articolo - Item | €/pc. | Articolo - Item | €/pc. | Articolo - Item | €/pc. | Descrizione | Per barche |
|-----------------|-------|-----------------|-------|-----------------|-------|------------------|------------|
| | | | | Chromo | | Description | For boats |
| L 36 80 530 | | L 36 74 530 | | L 36 79 530 | | Sinistra Port | <12 |
| L 36 80 550 | | L 36 74 550 | | L 36 79 550 | | Dritta Starboard | <12 |
| L 36 80 560 | | L 36 74 560 | | - | | Prua Bow | <12 |
| L 36 80 580 | | L 36 74 580 | | L 36 79 580 | | Poppa Stern | <12 |
| L 36 80 610 | | L 36 74 610 | | L 36 79 610 | | Combi | <12 |



**CONFEZIONE BLISTER SINGOLO
BLISTER SINGOLAR PKG SHIPYARD**

SUGGESTED ITEM



COMPLETE WITH



OMOLOGATI



**CONFEZIONE SFUSA CANTIERI
BULK PKG FOR SHIPYARD**

Fanali di via alogeni «CROCE DEL SUD» 12V

| Articolo - Item | €/pc. | €/box | Articolo - Item | €/pc. | €/box | Descrizione | Per barche |
|-----------------|-------|-------|-----------------|-------|-------|------------------|------------|
| Bulk 12 pcs. | | | Bulk 12 pcs. | | | Description | For boats |
| L 36 80 532 | | | L 36 74 532 | | | Sinistra Port | <12 |
| L 36 80 552 | | | L 36 74 552 | | | Dritta Starboard | <12 |
| L 36 80 562 | | | - | | | Prua Bow | <12 |
| L 36 80 582 | | | - | | | Poppa Stern | <12 |
| L 36 80 612 | | | L 36 74 612 | | | Combi | <12 |

«CROCE DEL SUD» halogen lights 12V

(This table is merged with the previous one for brevity, as it contains the same data.)



NAVIGATION KIT



Serie 4 fanali «CROCE DEL SUD»

Composta da:
112,5° Rosso, 112,5° Verde, 225° Bianco, 135° Bianco.

Set of 4 navigation lights «CROCE DEL SUD»

Set complete with:
112,5° Red, 112,5° Green, 225° White, 135° White.

| Articolo - Item | €/kit | Corpo-Body |
|-----------------|-------|------------|
| L 36 74 004 | | |
| L 36 80 004 | | |







Fanali di via alogeni «MINI STAR» 12V

Lenti in policarbonato. Montaggio a parete e chiusura a scatto.
Completati di lampadine 12V.
● Potenza 7W. ● Consumo 0,5A.

«MINI STAR» halogen lights 12V

Lens in Polycarbonate. Wall-mounting and snap closure system.
Complete with 12V bulbs.
● Power 7W. ● Consumption 0,5A.

| Articolo - Item | €/pc. | Articolo - Item | €/pc. | Descrizione Description | Per barche For boats |
|-----------------|-------|-----------------|-------|--|----------------------|
| L 59 80 530 | | L 59 74 530 | |  Sinistra Port | <12 |
| L 59 80 550 | | L 59 74 550 | |  Dritta Starboard | <12 |
| L 59 80 560 | | L 59 74 560 | |  Prua Bow | <12 |
| L 59 80 580 | | L 59 74 580 | |  Poppa Stern | <12 |
| L 59 80 610 | | L 59 74 610 | |  Combi | <12 |

AREA DI MONTAGGIO
FIXING AREA

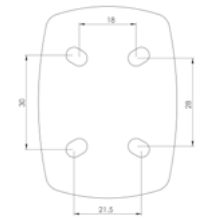

DISEGNO TECNICO
TECHNICAL DRAWING

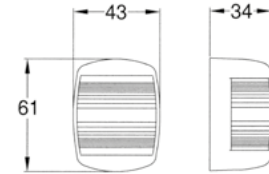

  12V made by  **CONFEZIONE BLISTER SINGOLO**
BLISTER SINGOLAR PKG SHIPYARD



COMPLETE WITH SUGGESTED ITEM







OMOLOGATI



Fanali di via alogeni «MINI STAR» 12V

«MINI STAR» halogen lights 12V

| Articolo - Item | €/pc. | €/box | Articolo - Item | €/pc. | €/box | Descrizione Description | Per barche For boats |
|-----------------|-------|-------|-----------------|-------|-------|--|----------------------|
| Bulk 12 pcs. | | | Cablato-Wired | | | | |
| L 59 74 532 | | | L 59 74 531C | | |  Sinistra Port | <12 |
| L 59 74 552 | | | L 59 74 551C | | |  Dritta Starboard | <12 |
| L 59 74 562 | | | L 59 74 561C | | |  Prua Bow | <12 |
| L 59 74 582 | | | L 59 74 581C | | |  Poppa Stern | <12 |
| L 59 74 612 | | | L 59 74 611C | | |  Combi | <12 |

CONFEZIONE SFUSA CANTIERI
BULK PKG FOR SHIPYARD



RICAMBI | SPARE PARTS

Supporto inclinato in ABS colore nero per applicare i fanali «Stella Polare» sui roll bar o su pareti inclinate

ABS socket black colour for mounting of «Stella Polare» lights on roll bar or inclined walls

| Articolo - Item | €/pc. | Inclinazione-Inclination |
|-----------------|-------|--------------------------|
| L 57 80 012 | | 12,5° |
| L 57 80 013 | | 13,4° |





Placca montaggio supporti fanali «STELLA POLARE»

Black gasket for navigation lights «STELLA POLARE»

| Articolo - Item | €/pc. |
|-----------------|-------|
| L 11 41 726 | |





RICAMBI | SPARE PARTS

Supporto a morsetto per battaglie

Clip for handrail

| Articolo - Item | €/pc. | Tubi/Pipe Ø mm. |
|-----------------|-------|-----------------|
| L 11 22 000 | | 22-30 |

made by  **AISI 316**

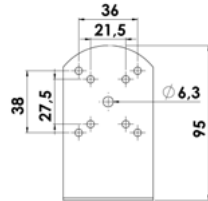
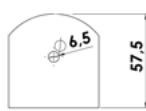

Supporto per applicazione ad albero

Bracket for masthead mounting

| Articolo - Item | €/pc. |
|-----------------|-------|
| L 11 55 000 | |

made by  **AISI 316**

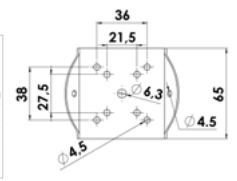
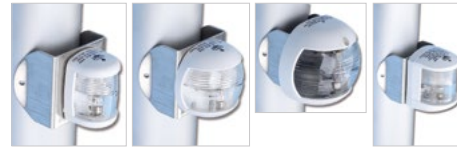
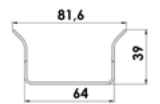

Supporto per superfici piane

Bracket for flat-mounting

| Articolo - Item | €/pc. |
|-----------------|-------|
| L 11 30 000 | |

made by  **AISI 316**

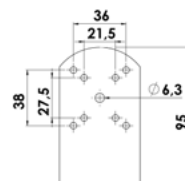
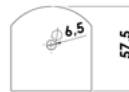

LUCI DI NAVIGAZIONE | NAVIGATION LIGHTS

Fanale di via e luce di coperta per alberi barche a vela

Masthead light for sailing boat

Fanale di via a 225° con abbinata la luce di coperta alogena da 10W. 12V.

Navigation light 225° with halogen deck light 10W. 12V.

| Articolo - Item | €/pc. | Montaggio-Fitting | kg. |
|-----------------|-------|--------------------|-------|
| L 36 00 100 | | Su albero-Masthead | 0,220 |

12V made by 

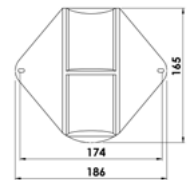

OMOLOGATO





LUCI DI NAVIGAZIONE | NAVIGATION LIGHTS

Fanali di via circolari 12V corpo nero

12V Round navigation lights black colour body

3 modelli.

3 models.

| Articolo - Item | €/pc. | Descrizione Description | kg. |
|-----------------|-------|--|-------|
| L 10 80 001 | |  Bianco-White | 0,220 |
| L 10 80 002 | |  Rosso-Verde Red-Green | 0,230 |
| L 10 80 003 | |  Rosso-Verde Red-Green + Bianco-White | 0,420 |

12V



L1080001

L1080002

L1080003

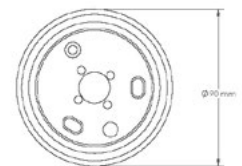
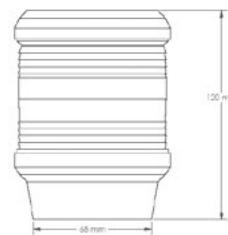

Fanali di via a montaggio orizzontale 12V 8W «ANTARES»

Navigation lights horizontal mounting 12V 8W «ANTARES»

Corpo fabbricato in ABS antiurto.

Body in shockproof ABS.

| Articolo - Item | €/pc. | Descrizione Description | Per barche For boats | kg. |
|-----------------|-------|--|----------------------|-------|
| L 66 74 530 | |  Sinistra-Port | <12 | 0,080 |
| L 66 74 550 | |  Dritta-Starboard | <12 | 0,080 |
| L 66 74 580 | |  Poppa-Stern | <12 | 0,080 |
| L 66 74 560 | |  Prua-Bow | <12 | 0,080 |
| L 66 74 610 | |  Combi | <12 | 0,080 |

12V

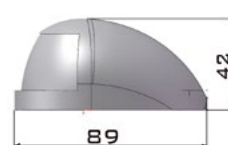

LUCI DI NAVIGAZIONE | NAVIGATION LIGHTS

Luci di via specchio di poppa alogene

Montaggio su specchio di poppa.
Omologate CE. Aisi 316.

Halogen stern lights

For stern mounting.
CE approved. Aisi 316.

| Articolo - Item | €/pc. | V | Per barche For boats mt. |
|-----------------|-------|----|-----------------------------|
| L 44 75 085 | | 12 | |
| L 44 13 085 | | 12 | <12 |

12V AISI 316 CE

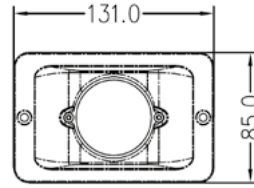
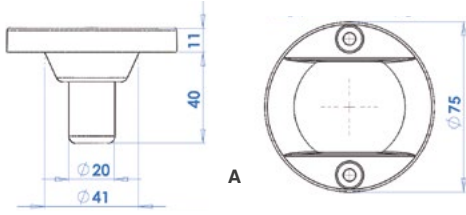

L4475085



L4413085

FANALI AL LED CONFORMI | COMPLYING LED LIGHTS

Luci di via specchio di poppa a LED

Montaggio su specchio di poppa.
Omologate CE. Aisi 316.

LED stern lights

For stern mounting.
CE approved. Aisi 316.

| Articolo - Item | €/pc. | V | W | Visibilità Visibility N.M. | Per barche For boats mt. |
|-----------------|-------|----|------|-------------------------------|-----------------------------|
| L 44 78 032 | | 12 | 0,32 | 2 | |
| L 44 32 172 | | 12 | 0,32 | 2 | <20 |

12V LED AISI 316 CE

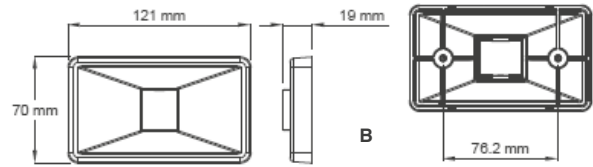
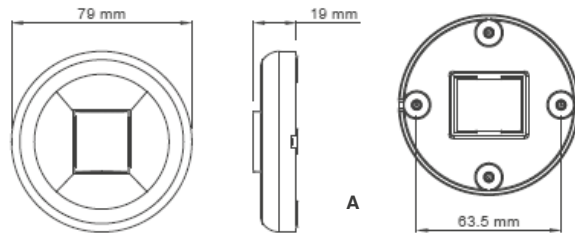

L4478032



L4432172

Luci di via «ORIONE» con sorgente luminosa a LED a basso consumo

Per imbarcazioni fino a 12 metri. 12V.

LED low consumption navigation lights «ORIONE»

For leisure boats up to 12 mt. 12V.

| Articolo - Item ABS Bianco-White | €/pair | Articolo - Item Aisi 316 | €/pair | Mod. | |
|-------------------------------------|--------|-----------------------------|--------|------|-----------------------|
| L 62 74 002 | | L 62 32 002 | | + | 112,5° DX + 112,5° SX |

12V LED

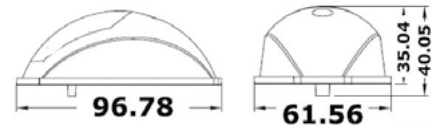

L6274002



L6232002

Luci di via «EVOLED» a led basso consumo in acciaio inox per fissaggio su piano

Omologati NMMA USA per imbarcazioni fino a 20 metri. In accordo con COLREG72 e ABYC A-16.

LED stainless steel low consumption navigation lights «EVOLED» for flat-mounting

NMMA USA approved for leisure boats up to 20 mt. In accordance with COLREG72 e ABYC A-16.

| Articolo - Item ABS Bianco-White | €/pair | Articolo - Item Aisi 316 | €/pair | Mod. | V |
|-------------------------------------|--------|-----------------------------|--------|------|-----------------------|
| L 70 74 218 | | L 70 32 218 | | + | 112,5° DX + 112,5° SX |

| Articolo - Item ABS Bianco-White | €/pc. | Articolo - Item Aisi 316 | €/pc. | Mod. | V |
|-------------------------------------|-------|-----------------------------|-------|------|------------|
| L 70 74 017 | | - | | | 225° Combi |

12V LED

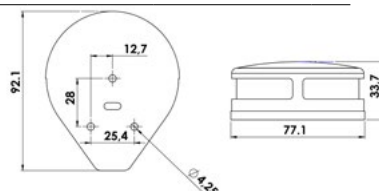

L7074218



L7074017

COMPLETO DI COMPLETE WITH



Art. L0700015 (pag. 193)

Fanali di via a pila per imbarcazioni e canotti **Battery powered navigation lights**

Fabbricati in materiale plastico. Completati di riflettori e di una clips per il fissaggio sui pulpiti delle imbarcazioni a vela. Funzionano con pile intercambiabili. Visibilità due miglia. 1,5V.

Made in plastic material. Complete with fastening clip for fitting on pulpit of sailing boats. Visibility 2 miles. 1,5V.

| Articolo - Item | €/pc. | Descrizione Description | Lampadina di ricambio Spare bulb | kg. |
|-----------------|-------|-------------------------|----------------------------------|-------|
| L 39 00 125 | | Poppa-Stern | L0700015 | 0,080 |
| L 37 00 125 | | Sinistra-Port | L0700015 | 0,080 |
| L 38 00 125 | | Dritta-Starboard | L0700015 | 0,080 |
| L 39 00 225 | | Prua-Bow | L0700015 | 0,080 |
| L 39 00 065 | | 360° | L0700015 | 0,080 |

madeby Funzionamento con 1 pila "C" (non inclusa). Running with 1 battery "C" (not included).

Serie tre fanali di via a pila «sinistra-dritta-prua»

Serie di fanali di via contenuti in confezione self-service. Funzionamento con batteria da 1,5V.

Set of 3 battery powered navigation lights «Port-Starboard-Bow»

Self-service packing. Powered by battery 1,5V.

| Articolo - Item | €/Set 3 pcs. | kg. |
|-----------------|--------------|-------|
| L 40 00 000 | | 0,310 |

madeby Funzionamento con 1 pila "C" (non inclusa). Running with 1 battery "C" (not included).



COMPLETO DI COMPLETE WITH



Art. L0700015 (pag. 193)

Asta luminosa a luce bianca 360°

Funzionamento attraverso 3 pile intercambiabili. 4,5V. Asta luminosa estraibile completa di attacco a parete.

Stern light pole white light 360°

Powered by 3 batteries 4,5V. Extractable pole complete with wall fitting device.

| Articolo - Item | €/pc. | Mod. | H mm. |
|-----------------|-------|---------------------------------|-------|
| L 39 00 075 | | Asta con fanale-Pole with light | 750 |

madeby Funzionamento con 3 pile "C" (non incluse). Running with 3 batteries "C" (not included).



Fanale combinato tre colori indicato per barche a vela

Completo di lampadina 12V. 10W. Montaggio sul piano.

Tricolour navigation light suitable for sailing boats

Complete with bulb 12V. 10W. Flat-mounting.

| Articolo - Item | €/pc. | Modello-Model | kg. |
|-----------------|-------|---------------|-------|
| L 39 03 360 | | Combi | 0,100 |



Fanale bianco 360° su asta

Funzionamento con batterie da 1,5V.

White 360° navigation light on pole

Operated by battery 1,5V.

| Articolo - Item | €/pc. | Mod. |
|-----------------|-------|---|
| L 20 14 260 | | Luce bianca 360° su asta 66 cm. con morsetto 360° white light on pole 66 cm. with bracket |



Fanale con asta inox combinato rosso/verde

Completo di lampadina 12V. 10W. e asta inox abbattibile. Per barche a vela.

Red/Green navigation light with stainless steel pole

Complete with bulb 12V. 10W. and stainless steel folding pole. For sailing boats.

| Articolo - Item | €/pc. | Modello-Model | Altezza-Height mm. | kg. |
|-----------------|-------|---------------|--|-------|
| L 39 03 240 | | | 240 | 0,180 |
| L 39 03 640 | | | 640 | 0,330 |
| L 39 00 003 | | | Vetri ricambio rosso/verde Red/Green spare glasses | 0,020 |



Luce di via a LED

Indicata per battelli. Fabbricata in materiale plastico.

LED navigation lights

Suitable for rubber boats. Manufactured in plastic material.

| Articolo - Item | €/pc. | Descrizione Description | H mm. | Attacco Fitting | kg. |
|-----------------|-------|-------------------------|-------|---------------------------|-------|
| L 65 15 272 | | Bianca-White | 650 | Morsetto-Sucker 0-160 mm. | 0,080 |
| L 65 15 273 | | Combi | 200 | Ventosa-Clamp | 0,080 |
| L 65 15 275 | | Bianca-White | - | Ventosa-Clamp | 0,080 |

Funzionamento con 3 pile "AAA" (non inclusa). Running with 3 batteries "AAA" (not included).



L6515275

L6515273

L6515272

Aqua LINE

LUCI SUBACQUEE | UNDERWATER LIGHTS

Luce subacquea ovale a 6 LED

Realizzata in policarbonato ad alta resistenza isolato da resine che garantiscono l'isolamento. Dal supporto interno escono soltanto i 2 fili per l'alimentazione.

Guscio: sigillato.

Adatta per barche, Jetski, pontili.

Realizzata per essere utilizzata esclusivamente immersa nell'acqua.

6 LED oval underwater light

Made in polycarbonate high resistance.

Housing: resin sealed.

Screw mounting.

Supplied with 2m cable.

Application: Boats, Jetskis, Docks.

Designed to be used in submerged applications only.

| Articolo - Item | €/pc. | Colore luce Light colour | mm. |
|-----------------|-------|-----------------------------|------------|
| L 44 06 012 | | Bianca-White 12000K | 68x206xH30 |
| L 43 06 012 | | Blu-Blue | 68x206xH30 |



SUGGESTED ITEM



| | |
|-----------------|---------------------------|
| LED WATTS | 12W |
| INPUT VOLTS | 9-32V DC Constant Voltage |
| INPUT AMPS | 1A |
| COLORE-COLOUR | Cool White 12000k/Blue |
| LUMENS | 1500lm |
| BEAM ANGLE | 60° - 90° |
| LIFE TIME | 50000 hours |
| WARRANTY | 2 Years |
| DIMENSIONI-SIZE | W68 x H30 x L206mm |
| LED CHIPS | 6 x 2W |
| HOUSING | Resin sealed |
| MOUNTING | Screw mounting |
| IP RATING | CE IP68 (40M) |
| CONNECTION | Cable 2 m |
| CONTROL | Non-dimmable |
| APPLICATION | Boats-Jetskis-Docks |

La luce deve essere utilizzata esclusivamente in immersione.
Module is designed to be used in submerged applications only.

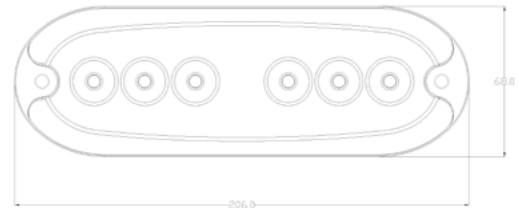

Base per luce 6 LED

Realizzata in Nylon antiurto.

Consente il montaggio della luce a 6 LED L4406012/ L4306012 senza forare l'imbarcazione.

| Articolo - Item | €/pc. |
|-----------------|-------|
| L 43 00 001 | |



Base for 6 LED light

Manufactured in shockproof Nylon. Suitable for mounting of 6 LED lights L4406012/L4306012 with no need of boat drilling.

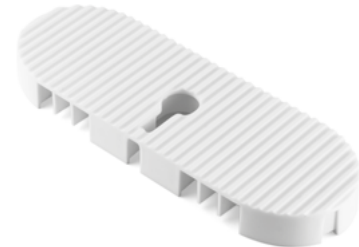

AREA DIDATTICA | EDUCATIONAL AREA

COSA SIGNIFICA IP? WHAT DOES IP MEAN?

| IP | X | Y |
|--|--|---|
| LETTERE CARATTERISTICHE (PROTEZIONE INTERNAZIONALE) | X indica il grado di protezione contro la penetrazione di corpi solidi estranei (da 0 a 6) 0 Nessuna protezione 1 Protetto contro corpi solidi superiori a 50 mm di diametro 2 Protetto contro corpi solidi superiori a 12 mm di diametro 3 Protetto contro corpi solidi superiori a 2,5 mm di diametro 4 Protetto contro corpi solidi superiori a 1 mm di diametro 5 Protetto contro le polveri (nessun deposito nocivo) 6 Totalmente protetto contro le polveri | Y indica il grado di protezione contro la penetrazione di liquidi (da 0 a 8) 0 Nessuna protezione 1 Protetto contro le cadute verticali di gocce d'acqua 2 Protetto contro le cadute di gocce d'acqua o pioggia fino a 15° dalla verticale 3 Protetto contro le cadute di gocce d'acqua o pioggia fino a 60° dalla verticale 4 Protetto contro gli spruzzi d'acqua da tutte le direzioni 5 Protetto contro i getti d'acqua 6 Protetto contro i getti d'acqua potenti 7 Protetto contro gli effetti delle immersioni temporanee 8 Protetto contro gli effetti delle immersioni continue |

| IP | X | Y |
|--|---|---|
| CHARACTERISTIC LETTERS (INTERNATIONAL PROTECTION) | X indicates the protection degree against the penetration of solid foreign bodies (from 0 to 6) 0 No protection 1 Protected against solid bodies over 50 mm in diameter 2 Protected against solid bodies over 12 mm in diameter 3 Protected against solid bodies over 2,5 mm in diameter 4 Protected against solid bodies over 1 mm in diameter 5 Protected against dust (no harmful deposit) 6 Fully protected against dust | Y indicates the protection degree against the penetration of liquids (from 0 to 8) 0 No protection 1 Protected against vertical fall of water drops 2 Protected against falling drops of water or rain up to 15° from the vertical line 3 Protected against falling drops of water or rain up to 60° from the vertical line 4 Protected against water splashes from all directions 5 Protected against water jets 6 Protected against strong water jets 7 Protected against the effects of temporary diving 8 Protected against the effects of continuous diving |

LUCI SUBACQUEE | UNDERWATER LIGHTS

| | |
|-----------------|---------------------------|
| LED WATTS | 6W |
| INPUT VOLTS | 9-32V DC Constant Voltage |
| INPUT AMPS | 500mA |
| COLORE-COLOUR | Cool White 12000k/Blue |
| LUMENS | 1000lm |
| BEAM ANGLE | 60° - 90° |
| LIFE TIME | 50000 hours |
| WARRANTY | 2 Years |
| DIMENSIONI-SIZE | Ø90 x H26 |
| LED CHIPS | 6 x 1W |
| HOUSING | Resin sealed |
| MOUNTING | Screw mounting |
| IP RATING | CE IP68 (40M) |
| CONNECTION | Cable 2 m |
| CONTROL | Non-dimmable |
| APPLICATION | Boats-Jetskis-Docks |

La luce deve essere utilizzata esclusivamente in immersione.
Module is designed to be used in submerged applications only.



Luce subacquea tonda a 6 LED

Realizzata in policarbonato ad alta resistenza isolato da resine che garantiscono l'isolamento. Dal supporto interno escono soltanto i 2 fili per l'alimentazione.
Guscio: sigillato.
Adatta per barche, Jetski, pontili.
Realizzata per essere utilizzata esclusivamente immersa nell'acqua.

6 LED round underwater light

Made in polycarbonate high resistance.
Housing: resin sealed.
Screw mounting.
Supplied with 2m cable.
Application: Boats, Jetskis, Docks.
Designed to be used in submerged applications only.

| Articolo - Item | €/pc. | Colore luce Light colour | mm. |
|-----------------|-------|-----------------------------|----------|
| L 44 06 006 | | Bianca-White 12000K | Ø 90xH26 |
| L 43 06 006 | | Blu-Blue | Ø 90xH26 |

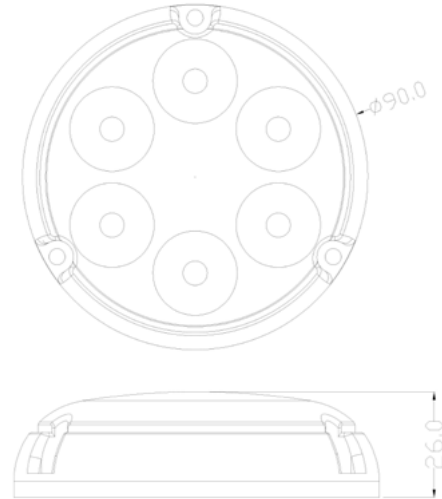

| | |
|-----------------|------------------------------|
| LED WATTS | 3W |
| INPUT VOLTS | 9-32V DC Constant Voltage |
| INPUT AMPS | 500mA |
| COLORE-COLOUR | Cool White 12000k/Blue/Green |
| LUMENS | 800lm |
| BEAM ANGLE | 60° - 90° |
| LIFE TIME | 50000 hours |
| WARRANTY | 2 Years |
| DIMENSIONI-SIZE | - |
| LED CHIPS | 3 x 1W |
| HOUSING | Resin sealed |
| MOUNTING | Screw mounting |
| IP RATING | CE IP68 (40M) |
| CONNECTION | Cable 2 m |
| CONTROL | Non-dimmable |
| APPLICATION | Boats-Jetskis-Docks |

La luce deve essere utilizzata esclusivamente in immersione.
Module is designed to be used in submerged applications only.

Luce subacquea a LED

Realizzata in policarbonato ad alta resistenza isolato da resine che garantiscono l'isolamento. Dal supporto interno escono soltanto i 2 fili per l'alimentazione.
Guscio: sigillato.
Adatta per barche, Jetski, pontili.
Realizzata per essere utilizzata esclusivamente immersa nell'acqua.

LED underwater light

Made in polycarbonate high resistance.
Housing: resin sealed.
Screw mounting.
Supplied with 2m cable.
Application: Boats, Jetskis, Docks.
Designed to be used in submerged applications only.

| Articolo - Item | €/pc. | Colore luce Light colour | Colore corpo Body colour |
|-----------------|-------|-----------------------------|-----------------------------|
| L 44 80 003 | | Bianca-White 12000K | Nero-Black |
| L 43 80 003 | | Blu-Blue | Nero-Black |
| L 44 06 003 | | Bianca-White 12000K | Bianco-White |
| L 43 06 003 | | Blu-Blue | Bianco-White |
| L 43 85 003 | | Verde-Green | Bianco-White |

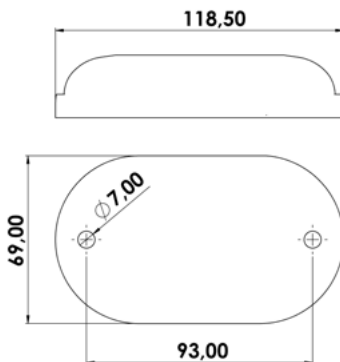

LUCI SUBACQUEE | UNDERWATER LIGHTS

Luce subacquea ovale a 6 LED

Realizzata in policarbonato ad alta resistenza isolato da resine che garantiscono l'isolamento. Dal supporto interno escono soltanto i 2 fili per l'alimentazione.

Guscio: sigillato.

Adatta per barche, Jetski, pontili.

Realizzata per essere utilizzata esclusivamente immersa nell'acqua.

6 LED oval underwater light

Made in polycarbonate high resistance.

Housing: resin sealed.

Screw mounting.

Supplied with 2m cable.

Application: Boats, Jetskis, Docks.

Designed to be used in submerged applications only.

| Articolo - Item | €/pc. | Colore luce Light colour | Colore corpo Body colour |
|-----------------|-------|-----------------------------|-----------------------------|
| L 44 10 074 | | Bianca-White 12000K | Nero-Black |
| L 44 10 053 | | RGB | Nero-Black |

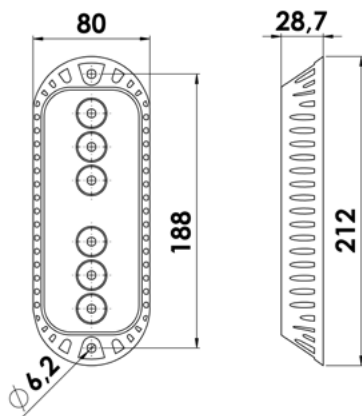

| | |
|------------------|---------------------------------------|
| LED COLOUR | White/WiFi RGB |
| LED TYPE | 6pcs high power BRIDGELUX/EPISTAR LED |
| MATERIAL | Fully Epoxy sealed |
| PROTECTION CLASS | IPX8-RoHS-CE cert underwater 40M |
| DIMENSIONI-SIZE | 206 x 75 x 30 mm |
| POWER | Single colour 10W-RGB 7W-12V AC/DC |
| CORD LENGTH | 2M |
| LIGHT ANGLE | 60°-90° |
| ILLUMINATION | 900lm |
| APPLICATION | Boats-Jetskis-Docks-Yacht |
| MOUNTING | Screw mounting |
| WORKING PERIOD | 8 hours per day |
| RGB SYSTEM | Controlled by WiFi device/DMX System |
| PACKAGE | PVC display box |
| WARRANTY | 2 Years |

La luce deve essere utilizzata esclusivamente in immersione.
Module is designed to be used in submerged applications only.

Luce subacquea ovale a 12 LED

Realizzata in policarbonato ad alta resistenza isolato da resine che garantiscono l'isolamento. Dal supporto interno escono soltanto i 2 fili per l'alimentazione.

Guscio: sigillato.

Adatta per barche, Jetski, pontili.

Realizzata per essere utilizzata esclusivamente immersa nell'acqua.

12 LED oval underwater light

Made in polycarbonate high resistance.

Housing: resin sealed.

Screw mounting.

Supplied with 2m cable.

Application: Boats, Jetskis, Docks.

Designed to be used in submerged applications only.

| Articolo - Item | €/pc. | Colore luce Light colour | Colore corpo Body colour |
|-----------------|-------|-----------------------------|-----------------------------|
| L 44 20 074 | | Bianca-White 12000K | Nero-Black |
| L 44 20 053 | | RGB | Nero-Black |

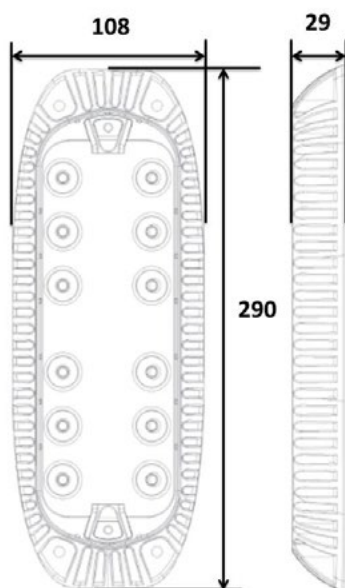

| | |
|------------------|---------------------------------------|
| LED COLOUR | White/WiFi RGB |
| LED TYPE | 6pcs high power BRIDGELUX/EPISTAR LED |
| MATERIAL | Fully Epoxy sealed/Glass cover |
| PROTECTION CLASS | IPX8-RoHS-CE cert underwater 40M |
| DIMENSIONI-SIZE | 290 x 108 x 29 mm |
| POWER | Single colour 20W-RGB 15W-12V AC/DC |
| CORD LENGTH | 2M |
| LIGHT ANGLE | 60°-90° |
| ILLUMINATION | 1800lm |
| APPLICATION | Boats-Jetskis-Docks |
| MOUNTING | Screw mounting |
| WORKING PERIOD | 8 hours per day |
| RGB SYSTEM | Controlled by WiFi device/DMX System |
| PACKAGE | PVC display box |
| WARRANTY | 2 Years |

La luce deve essere utilizzata esclusivamente in immersione.
Module is designed to be used in submerged applications only.

LUCI SUBACQUEE | UNDERWATER LIGHTS

12

Luce subacquea a 6 LED

Realizzata in Aisi 316.
Montaggio allo specchio di poppa.
Cavo 1,5 mt.
Installazione sotto la linea di galleggiamento.

6 LED underwater light

Manufactured in Aisi 316.
For transom mounting.
Cable 1,5 mt.
Installation below the waterline.

| Articolo - Item | €/pc. | Alimentazione Power | Durata LED h. LED working h. | Lumen | LED | Colore LED LED colour | mm. | K. | Angolo Angle | Wattage |
|-----------------|-------|---------------------|------------------------------|-------|------|-----------------------|----------|-----------|--------------|---------|
| L 44 06 299 | | 6-32V | 50.000 | 600 | 6x3W | | Ø 94xH21 | 5500-6300 | 120° | 15 |
| L 43 06 299 | | 6-32V | 50.000 | 300 | 6x3W | | Ø 94xH21 | | 120° | 15 |

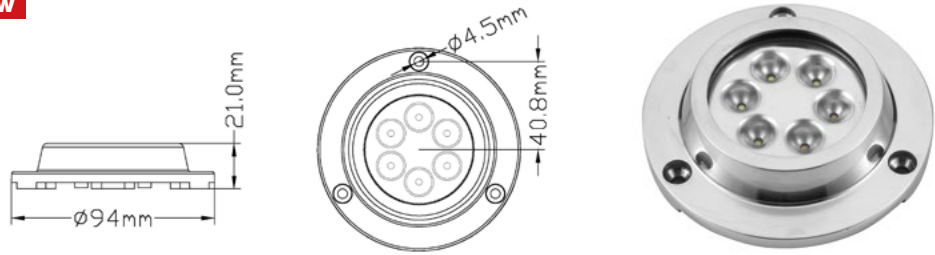

Luce subacquea a 4 LED

Realizzata in Aisi 316.
Montaggio allo specchio di poppa.
Cavo 1,5 mt.
Installazione sotto la linea di galleggiamento.

4 LED underwater light

Manufactured in Aisi 316.
For transom mounting.
Cable 1,5 mt.
Installation below the waterline.

| Articolo - Item | €/pc. | Alimentazione Power | Durata LED h. LED working h. | Lumen | LED | Colore LED LED colour | mm. | K. | Angolo Angle | Wattage |
|-----------------|-------|---------------------|------------------------------|-------|------|-----------------------|----------|-----------|--------------|---------|
| L 44 04 299 | | 6-32V | 50.000 | 300 | 4x3W | | Ø 94xH21 | 5500-6300 | 120° | 11 |
| L 43 04 299 | | 6-32V | 50.000 | 150 | 4x3W | | Ø 94xH21 | | 120° | 11 |

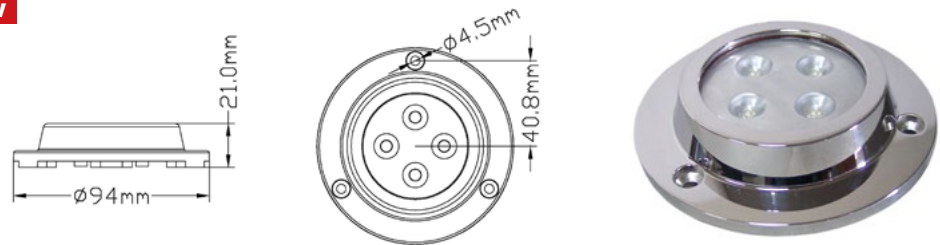

Luce subacquea a 6 LED

Funzionamento attraverso 3 pile intercambiabili. 4,5V.
Asta luminosa estraibile completa di attacco a parete.

6 LED underwater light

Powered by 3 batteries 4,5V.
Extractable bright pole complete with wall fitting device.

| Articolo - Item | €/pc. | Colore LED LED colour | Lumen | Wattage | kg. |
|-----------------|-------|-----------------------|-------|---------|-------|
| L 44 06 536 | | | 60 | 10 | 0,120 |
| L 43 06 536 | | | 15 | 10 | 0,120 |

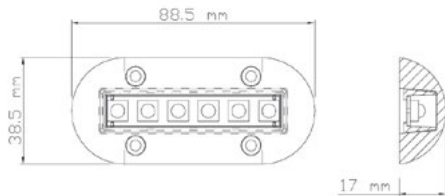

GARANTITA SOLO SE COMPLETAMENTE IMMERSA
GUARANTEED ONLY IF COMPLETELY SUBMERGED

AREA DIDATTICA | EDUCATIONAL AREA

COME SI MISURA LA LUMINOSITÀ? HOW TO MEASURE THE BRIGHTNESS?

LUMINOSITÀ (FLUSSO LUMINOSO)

La quantità di luce emessa da una lampadina si misura in **lumen** (lm). Le vecchie lampadine a incandescenza/alogene in **watt** (W). I watt, in realtà, indicano l'energia consumata, e non l'effettiva luce emessa. A parità di watt consumati, le moderne lampadine (a LED o con altre tecnologie a basso consumo) emettono una luminosità molto superiore.
A puro titolo informativo, riportiamo una tabella che aiuta a passare dalle **lampade alogene** a qualsiasi lampada moderna.

BRIGHTNESS (LIGHT OUTPUT)

The amount of light emitted by a light bulb is measured in **lumens** (lm). The old incandescent/halogen bulbs in **watts** (W). The watts actually indicate the energy consumed, and not the actual light emitted. With the same watts consumed, modern bulbs (with LED or other low consumption technologies) emit a much higher brightness.
For information only, we show a table that helps to switch from halogen lamps to any other modern lamp.

| | | | | | | | | | | |
|--|----------|----------|----------|----------|-----------|-----------|-----------|-----------|-----------|-----------|
| Una sorgente di luce con flusso luminoso di A light source with light output of | 10 lumen | 20 lumen | 50 lumen | 70 lumen | 100 lumen | 150 lumen | 200 lumen | 250 lumen | 350 lumen | 500 lumen |
| Sostituisce una lampada alogena da Can replace a halogen lamp from | 0,5 watt | 1 watt | 3 watt | 4 watt | 6 watt | 9 watt | 12 watt | 15 watt | 20 watt | 30 watt |

Proiettore portatile a LED impermeabile

Corpo in Abs e caoutchouc. Colore bianco-blue. 3 posizioni: intenso, standard, SOS. Provvisto di blocco pulsante per lasciare luce fissa. Dimensioni:
 • Lunghezza 140 mm.
 • Altezza 165 mm.
 • Altezza manico 90 mm.

LED waterproof search light

ABS body and rubber. 3 different functions: high fixed light, low fixed light, SOS signal. Provided with lock button and support. Size:
 • Length 140 mm.
 • Height 165 mm.
 • Handle height 90 mm.

| Articolo - Item | €/pc. | Portata-Visibility mt. | kg. |
|-----------------|-------|------------------------|-----|
| L 22 35 067 | | 450 | |



Funzionamento con 3 batterie "C" (non include).
 Running with 3 batteries "C" (not included).



Mini lampada subacquea a LED impermeabile fino a 100 mt di profondità

Fabbricata in policarbonato e gomma. Provvista di 1 led a 3 watt.

Mini LED diving torch light waterproof up to 100 mt deep

Manufactured in polycarbonate and rubber. 1 led x 3 watt

| Articolo - Item | €/pc. | mm. | Lumen | Impermeabile fino a Diving mt. | kg. |
|-----------------|-------|------------|-------|--------------------------------|-----|
| L 22 00 323 | | Ø 50 x 160 | 150 | 100 | |



Funzionamento con 3 batterie "C" (non include).
 Running with 3 batteries "C" (not included).



Torcetta luminosa anfibia

Accensione all'avviamento.

Torch light

Operating by unscrewing.

| Articolo - Item | €/pc. | Mod. | kg. |
|-----------------|-------|----------------|-------|
| L 19 77 002 | | Normale-Normal | 0,200 |



Funzionamento con 3 batterie "C" (non include).
 Running with 3 "C" batteries (not included).



Torcia luminosa impermeabile

Fabbricata in plastica e rivestita in gomma. Torcia con autonomia superiore a 50 ore.

Waterproof torch light

Manufactured in plastic and covered with rubber. Duration > 50 hours.

| Articolo - Item | €/pc. | Mod. | kg. |
|-----------------|-------|-------------------------|-------|
| L 20 00 021 | | Impermeabile-Waterproof | 0,190 |



Funzionamento con 3 batterie "C" (non include).
 Running with 3 "C" batteries (not included).

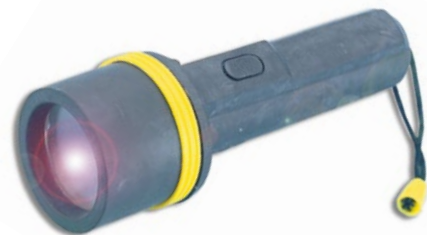



Faro da coperta

Fabbricato in gomma impermeabile ed acciaio inox. Completo di lampada alogena.
Dimensioni:
• Lunghezza 155 mm.
• Altezza 100 mm.
• Ø 110 mm.

Marine search light

Manufactured in waterproof rubber and stainless steel. With halogen bulb.
Size:
• Length 155 mm.
• Height 100 mm.
• Ø 110 mm.

| Articolo - Item | €/pc. | Colore Colour | Montaggio Mounting | Lightbulb icon | kg. |
|-----------------|-------|------------------|-----------------------|----------------|-------|
| L 22 00 806 | | | Coperta-Deck mounting | 12V 35W | 0,450 |



12V

Faro base quadra a radio control

Faro radiocomandato compatto impermeabile. Bulbo alogeno stagno da 12V-55W. Rotazione orizzontale 440° - Angolo verticale 120°. Dimensioni:
• Lunghezza 265 mm.
• Larghezza 295 mm.
• Altezza 300 mm.

Portable search lamp with radio control

Compact waterproof radio-controlled lamp. Waterproof halogen bulb 12V-55W. Horizontal rotation 440° - Vertical angle 120°. Size:
• Length 265 mm.
• Width 295 mm.
• Height 300 mm.

| Articolo - Item | €/pc. | Colore Colour | Potenza candele Candles power | Portata Visibility mt. | Volts | kg. |
|-----------------|-------|------------------|----------------------------------|------------------------------|-------|-----|
| L 22 80 190 | | | 220.000 | 400 | 12 | |



12V



Proiettore portatile con bulbo ottico «Alogeno»

Fabbricato in Abs cromato. Con presa accendisigari a 12V.

Halogen portable searchlamp

Manufactured in chromed Abs. With cigarette lighter 12V.

| Articolo - Item | €/pc. | Parabola Light aperture Ø mm. | Lunghezza cavo Cable length mm. | Portata Visibility mt. | Volts | kg. |
|-----------------|-------|----------------------------------|------------------------------------|---------------------------|-------|-------|
| L 22 10 650 | | 110 | 2000 | 600 | 12 | 0,550 |



12V



SUGGESTED ITEM



Art. L0601331 (pag. 240)

Proiettore portatile

Con presa accendisigari a 12V.

Halogen portable searchlamp

With cigarette lighter 12V.

| Articolo - Item | €/pc. | Mod. | Lunghezza cavo Cable length mm. | Ø mm. | Volts | kg. |
|-----------------|-------|--------------------------------|------------------------------------|-------|-------|-------|
| L 22 06 027 | | Con impugnatura With handle | 2800 | 100 | 12 | 0,480 |



12V



SUGGESTED ITEM



Art. L0601331 (pag. 240)

Faro di profondità alogeno con attacco al pulpito

Costruito in ABS con staffa in alluminio anodizzato e base in acciaio inox. Bulbo ottico Wagner con portata max di 600 mt. Bulbo a doppio filamento. Luce corta a largo fascio 100 mt. Snodo totale con regolazione in altezza e in rotazione 360°, entrambi frizionabili. Faro sfilabile dal basamento con cavo estensibile fino a 2 mt. Interruttore speciale a tenuta stagna con cappuccio in gomma incorporato nella calotta posteriore. Inalterabilità agli agenti atmosferici. Inalterabilità del bulbo ottico che, essendo sotto vuoto, non patisce né l'umidità, né il salino. Grande potenza e leggerezza.

Halogen high-beam light fitted with pulpit coupling

Manufactured in ABS with anodized aluminium bracket and stainless steel base. Wagner optical bulb with 600 mt. max. capacity. Short light with 100 mt. wide beam. Full 360° rotation and elevation joint, frictioning. Detachable light with 2 mt. extension cable. Special waterproof switch, fitted with rubber cover, built-in into the rear dome. Equipped with waterproof plug for flush or flat mounting. Weather resistant. Vacuum-sealed unbreakable optic bulb, humidity and salt resistant. Great power and light weight.

| Articolo - Item | €/pc. | Volts | Watt | Luce di profondità Depth light mt. | Per tubi For pipes mm. | Preso Socket | Lampadina ricambio Spare bulb | kg. |
|-----------------|-------|-------|-------------|---------------------------------------|---------------------------|---------------------------------|-------------------------------------|-------|
| L 22 25 022 | | 12 | 100 +100 | 600 | 22/25 | Bipolare Plug connection | L2212000 | 1,240 |
| L 22 25 604 | | 12 | 100 +100 | 600 | 22/25 | Accendisigari Cigarette plug | L2212000 | 1,240 |



COMPLETO DI-COMPLETE WITH



SUGGESTED ITEM

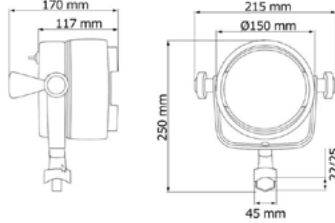

Faro di profondità alogeno con attacco al piano

Costruito in ABS con staffa in alluminio anodizzato e base in acciaio inox. Bulbo ottico Wagner con portata max di 600 mt. Bulbo a doppio filamento. Luce corta a largo fascio 100 mt. Snodo totale con regolazione in altezza e in rotazione 360°, entrambi frizionabili. Faro sfilabile dal basamento con cavo estensibile fino a 2 mt. Interruttore speciale a tenuta stagna con cappuccio in gomma incorporato nella calotta posteriore. Inalterabilità agli agenti atmosferici. Inalterabilità del bulbo ottico che, essendo sotto vuoto, non patisce né l'umidità, né il salino. Grande potenza e leggerezza.

Halogen high-beam light flat-mounting

Manufactured in ABS with anodized aluminium bracket and stainless steel base. Wagner optical bulb with 600 mt. max. capacity. Short light with 100 mt. wide beam. Full 360° rotation and elevation joint, frictioning. Detachable light with 2 mt. extension cable. Special waterproof switch, fitted with rubber cover, built-in into the rear dome. Equipped with waterproof plug for flush or flat mounting. Weather resistant. Vacuum-sealed unbreakable optic bulb, humidity and salt resistant. Great power and light weight.

| Articolo - Item | €/pc. | Volts | Watt | Luce di profondità Depth light mt. | Basetta-Base Ø mm. | Preso Socket | Lampadina ricambio Spare bulb | kg. |
|-----------------|-------|-------|-------------|---------------------------------------|-----------------------|---------------------------------|-------------------------------------|-------|
| L 22 12 022 | | 12 | 100 +100 | 600 | 65 | Bipolare Plug connection | L2212000 | 1,230 |
| L 22 01 604 | | 12 | 100 +100 | 600 | 65 | Accendisigari Cigarette plug | L2212000 | 1,230 |



COMPLETO DI-COMPLETE WITH



SUGGESTED ITEM

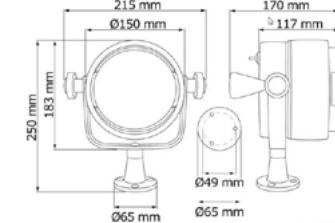

Basetta attacco al piano

Deck connection base

| Articolo - Item | €/pc. | Ø mm. | kg. |
|-----------------|-------|-------|-------|
| L 22 00 022 | | 65 | 0,140 |

Bulbo di ricambio

Spare bulb

| Articolo - Item | €/pc. | kg. |
|-----------------|-------|-------|
| L 22 12 000 | | 0,350 |





Faro elettrico LED quadrato

Carcassa in resine ad alta resistenza anti-corrosione. Completamente stagni. Rotazione orizzontale 355°, a 2 velocità. Rotazione 355° e 70°. Gruppo di LED OSRAM di alta qualità. Consumo 27 W. Radiocomando classico fornito con staffa per fissaggio alla plancia.

LED electric square spotlight

Body manufactured in white high-resistance and anti-corrosion resins. Totally watertight. 2-speed 355° horizontal rotation. 355° and 70° rotation. LED version with OSRAM high-quality LED unit. Consumption 27W. Radio remote control with bracket for mounting on the bridge.

| Articolo - Item | €/pc. | Candele Candles CD | Volts | Watt | K | Lumen | LED | Angolo LED LED Angle | kg. |
|-----------------|-------|-----------------------|-------|------|------|-------|-------|-------------------------|-----|
| L 22 12 450 | | 120.000 | 10-30 | 27 | 6000 | 2000 | 12x3W | 70° | |

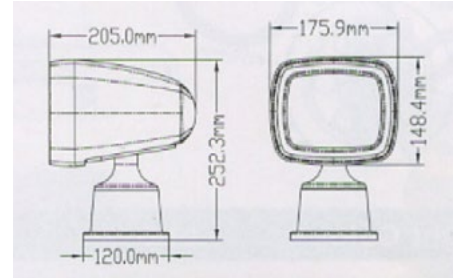

Faro elettrico LED tondo

Carcassa in resine ad alta resistenza anti-corrosione. Completamente stagni. Rotazione orizzontale 355°, a 2 velocità. Rotazione 355° e 70°. Gruppo di LED OSRAM di alta qualità. Consumo 27 W. Radiocomando classico fornito con staffa per fissaggio alla plancia.

LED electric round spotlight

Body manufactured in white high-resistance and anti-corrosion resins. Totally watertight. 2-speed 355° horizontal rotation. 355° and 70° rotation. LED version with OSRAM high-quality LED unit. Consumption 27W. Radio remote control with bracket for mounting on the bridge.

| Articolo - Item | €/pc. | Candele Candles CD | Volts | Watt | K | Lumen | LED | Angolo LED LED Angle | kg. |
|-----------------|-------|-----------------------|-------|------|------|-------|------|-------------------------|-----|
| L 22 09 455 | | 120.000 | 10-30 | 27 | 6000 | 2000 | 9x3W | 70° | |

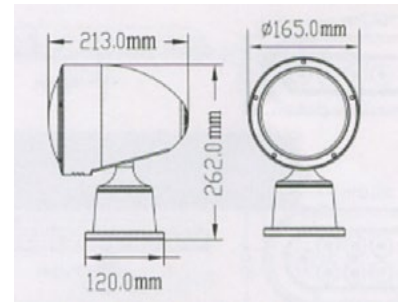

L2274622

Faro «Super-light» con attacco in piano

Fabbricato in alluminio. Led 160-190 Lumen. Angolo 110°. Volts 10-30, Watt 10,5. Colore led bianco 5500-6300 K. Provisto di base cromata, filo allungabile e attacco impermeabile con presa. Rotazione di 360°. Dimensioni: 170x142x215H mm. Faro Ø 140 mm.

Spotlight «Super Light» with flat mounting

Manufactured in aluminium. Led 160-190 Lumen. Angle 110°. Volts 10-30, Watt 10,5. Led colour white 5500-6300 K. Supplied with chrome-plated base, extensible wire and waterproof plug for connection. 360° rotation. Size: 70x142x215H mm. Spotlight Ø 140 mm.

| Articolo - Item | €/pc. | Colore-Colour | Mod. | Volts | kg. |
|-----------------|-------|---------------|--------------------------------|-------|---------------|
| L 22 74 622 | | | Presa bipolare-Plug connection | 12-24 | 9LEDx3W 1,150 |
| L 22 74 601 | | | Accendisigari-Cigarette plug | 12-24 | 9LEDx3W 1,150 |



L2274601

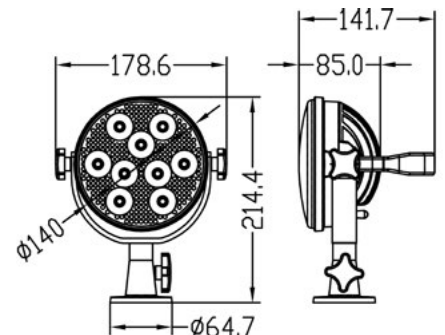

Faro impermeabile a LED

Supporto in acciaio inox.
Fonte luminosa: 6 led x 3W.
Tensione operativa: 10-30VDC.
Carcassa Alu rettangolare bianco.
Temperatura colore: 6000K.
Potenza: 18 Watt.
Lumens 1200.

High power waterproof LED spotlight

Stainless steel holder.
Light source: 6 led x 3W.
Operating voltage: 10-30VDC.
White rectangular alu cover.
Colour temperature: 6000K.
Power: 18 Watt.
Lumens 1200.

| Articolo - Item | €/pc. | mm. | kg. |
|-----------------|-------|------------------|-------|
| L 22 50 160 | | H45 x L160 x P63 | 0,180 |



Faro impermeabile a LED

Fonte luminosa: 9 led x 3W.
Tensione operativa: 10-30VDC.
Carcassa Alu quadrato bianco.
Temperatura colore: 6000K.
Potenza: 27 Watt.
Lumens 1600.

High power waterproof LED spotlight

Light source: 9 led x 3W.
Operating voltage: 10-30VDC.
White square alu cover.
Colour temperature: 6000K.
Power: 27 Watt.
Lumens 1600.

| Articolo - Item | €/pc. | mm. | kg. |
|-----------------|-------|-------------------|-------|
| L 22 30 105 | | H128 x L110 x P35 | 0,210 |

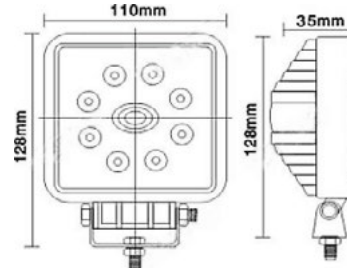

Faro impermeabile a LED

Fonte luminosa: 6 led x 3W luce intensa.
Tensione operativa: 9-30VDC.
Carcassa Alu rettangolare bianco.
Temperatura colore: 6000K.
Potenza: 18 Watt.
Lumens 1080.

High power waterproof LED spotlight

Light source: 6 led x 3W high intensity CREE LEDs.
Operating voltage: 9-30V DC.
White rectangular diecast alu housing.
Colour temperature: 6000K.
Power: 18 Watt.
Lumens 1080.

| Articolo - Item | €/pc. | mm. | kg. |
|-----------------|-------|------------------|-------|
| L 22 73 099 | | H107 x L99 x P73 | 0,550 |

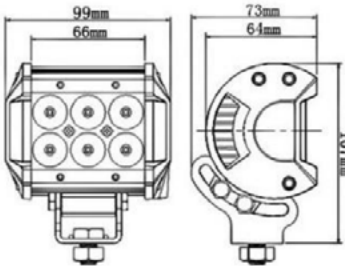

Faro impermeabile a LED

Fonte luminosa: 16 led x 3W.
Tensione operativa: 10-30VDC.
Carcassa Alu quadrato bianco.
Temperatura colore: 6000K.
Potenza: 48 Watt.
Lumens 2880.

High power waterproof LED spotlight

Light source: 16 led x 3W.
Operating voltage: 10-30VDC.
White square alu cover.
Colour temperature: 6000K.
Power: 48 Watt.
Lumens 2880.

| Articolo - Item | €/pc. | mm. | kg. |
|-----------------|-------|-------------------|-------|
| L 22 16 110 | | H164 x L110 x P60 | 0,550 |

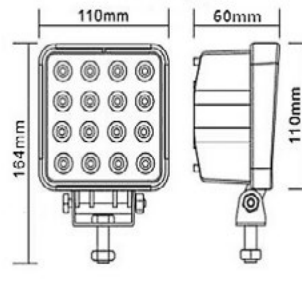

Faro impermeabile a LED

Modello impermeabile con dissipatore.
Fonte luminosa: 6 led.
Tensione operativa: 9~36V.
Consumo: 18W.
Coperchio rettangolare bianco.
Intensità luce: 937 Lumens.
Temperatura colore: 5500K~6300K.

High power waterproof LED spotlight

Water resistant with casting heat sink.
Light source: 6 Leds.
Operating voltage: Multi-Voltage 9~36V.
Power consumption: 18W.
White rectangular cover.
Light output: 937 Lumens:
Colour temperature: 5500K~6300K.

| Articolo - Item | €/pc. | mm. | kg. |
|-----------------|-------|------------|-------|
| L 22 74 058 | | 110x100x55 | 0,470 |



Faro impermeabile a LED

Modello impermeabile con dissipatore.
Fonte luminosa: 10 led.
Tensione operativa: 9~36V.
Consumo: 13W.
Coperchio tondo bianco.
Intensità luce: 1050 Lumens.
Temperatura colore: 6119K.

High power waterproof LED spotlight

Water resistant with casting heat sink.
Light source: 10 Leds.
Operating voltage: Multi-Voltage 9~36V.
Power consumption: 13W.
White round cover.
Light output: 1050 Lumens:
Colour temperature: 6119K.

| Articolo - Item | €/pc. | mm. | kg. |
|-----------------|-------|---------|-------|
| L 22 74 033 | | Ø110x50 | 0,478 |



VISIT OUR B2B AREA

CREATE A CUSTOMER ACCOUNT

CHECK AVAILABILITY & QUANTITY OF ITEMS

CHECK YOUR COMMERCIAL CONDITION

PLACE YOUR ORDER

TRACK YOUR ORDER STATUS

TRACK YOUR PAYMENT PROCESS

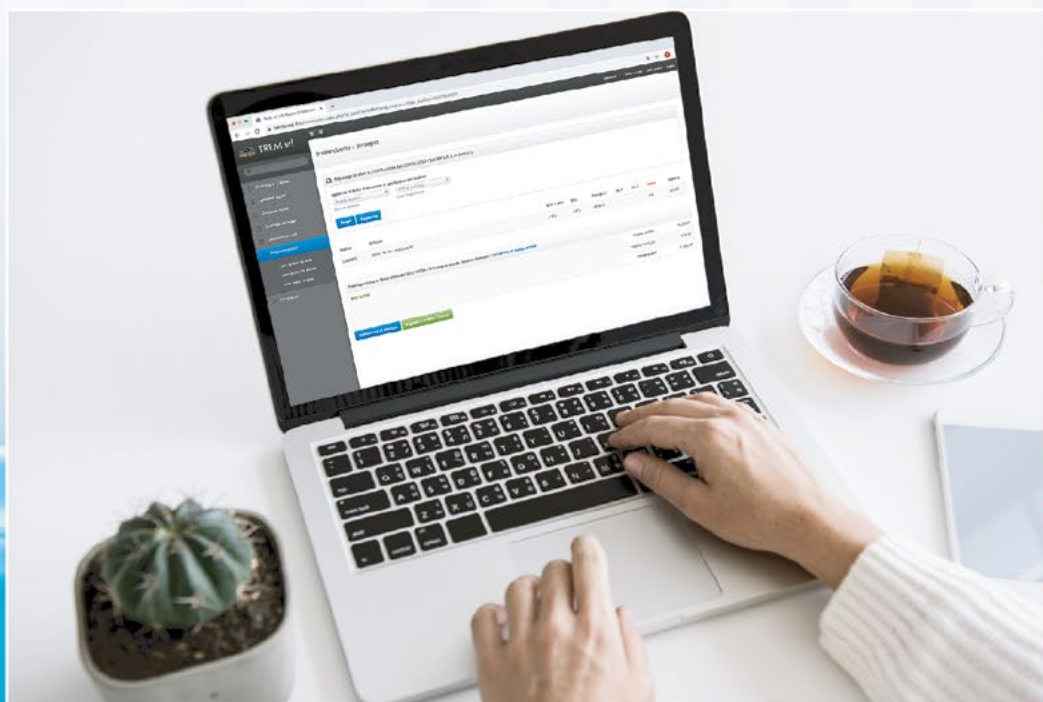

WWW.TREM.NET



AURORA

LIGHTING

AURORA è una linea di prodotti di alta fascia, realizzata appositamente per uso nautico, studiata e disegnata per collimare con le esigenze della tua barca.

AURORA is a high-end product line, made specifically for nautical use, designed to match the needs of your boat.

- GRADI DI PROTEZIONE SINO A IP67
- PROECTION GRADE UP TO IP67



- REALIZZATE IN AISI 316
- MANUFACTURED IN AISI 316

- LUMINOSITÀ FINO A 344 Lumen
- BRIGHTNESS UP TO 344 Lumen

- VOLTAGGI DA 10 A 32VDC
- VOLTAGE 10-32VDC



- TUTTI I FARETTI SONO PROVVISI DI PRESA USB
- ALL SPOTLIGHTS ARE SUPPLIED WITH USB SOCKET

FARETTI A LED «AURORA» | «AURORA» LED SPOTLIGHTS

LUCI INTERNO ED ESTERNO | INDOOR & OUTDOOR LIGHTING



Faretto a LED snodato con presa USB

Fabbricato in alluminio cromato + collo in acciaio ricoperto in gomma siliconica. Provvisto di interruttore a sfioro. Luce dimmerata.

Articulated LED spotlight with USB socket

Manufactured in chromed aluminium + steel neck covered with silicone rubber. Equipped with a soft touch switch. Dimmed light.

| Articolo - Item | €/pc. | Power | Voltage | Light Source | Colour | Lumen | Max intensity CD | Beam Angle | CRI | IP |
|-----------------|-------|--------|----------|--------------|-------------|-------|------------------|------------|-----|----|
| L 44 17 055 | | 3,3+6W | 10-32VDC | 3W COB LED | White 3000K | 270 | 488 | 38,6° | >80 | 20 |

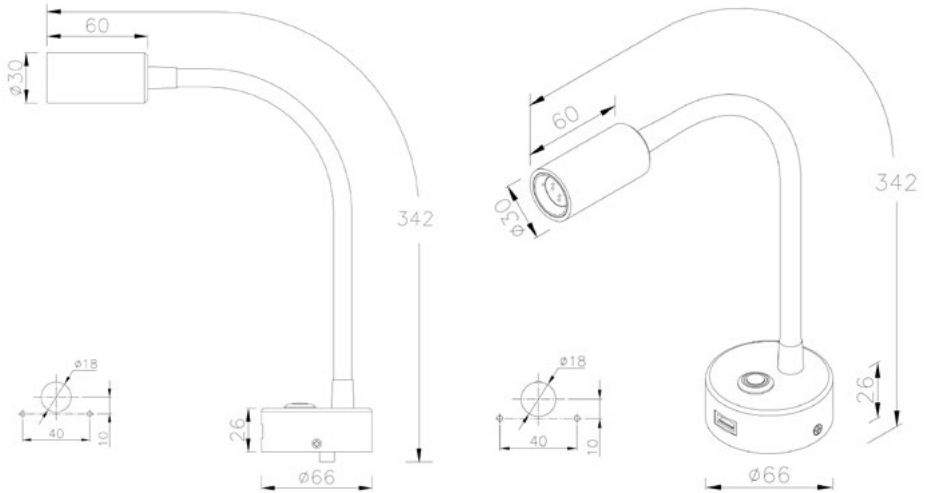

Faretto a LED con presa USB

Fabbricato in alluminio cromato. Provvisto di interruttore a sfioro. Luce dimmerata.

LED spotlight with USB socket

Manufactured in chromed aluminium. Equipped with a soft touch switch. Dimmed light.

| Articolo - Item | €/pc. | Power | Voltage | Light Source | Colour | Lumen | Max intensity CD | Beam Angle | CRI | IP |
|-----------------|-------|--------|----------|--------------|------------------|-------|------------------|------------|-----|----|
| L 44 72 032 | | 3,5+6W | 10-32VDC | 3W COB LED | Warm white 3000K | 213 | 637 | 28,7° | >80 | 20 |

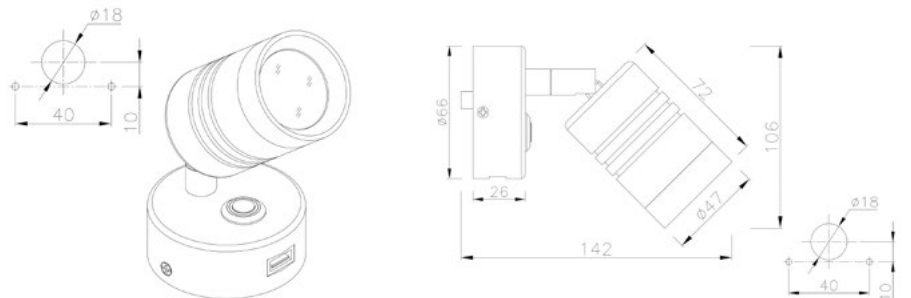

AIUTO NELLA LETTURA | HELP IN READING

POWER: è la potenza
VOLTAGE: è l'alimentazione
LIGHT SOURCE: il modello di LED fornito all'interno
COLOUR: temperatura del colore (vedi pag. 193)
LUMEN: Luminosità (vedi pag. 166)
CD: Massima intensità luminosa
BEAN ANGLE: Angolo di luminosità
CRI: Indice resa cromatica
IP: Grado di protezione (vedi pag. 163)

POWER: is power
VOLTAGE: is current supply
LIGHT SOURCE: is the LED model supplied
COLOUR: Colour temperature (see pag. 193)
LUMEN: Brightness (see pag. 166)
CD: Max. light intensity
BEAN ANGLE: Brightness angle
CRI: Colour rendering index
IP: Protection degree (see pag. 163)

LUCI DI CORTESIA A LED «AURORA» | «AURORA» LED COURTESY LIGHTS

Luce di cortesia a LED da incasso

Fabbricata in Aisi 316 e corpo in plastica. Montaggio con viti.

Recessed mounting LED courtesy light

Manufactured in Aisi 316 and plastic body. Screws mounting.

| Articolo - Item | €/pc. | Power | Voltage | Light Source | Colour | Lumen | Max intensity CD | Beam Angle | Cut out mm. | CRI | IP |
|-----------------|-------|-------|----------|--------------|------------------|-------|------------------|------------|-------------|-----|----|
| L 44 06 038 | | 0,6W | 10-32VDC | 2835 SMD LED | Warm white 3000K | 6 | 11 | 24° | 19 | >80 | 65 |

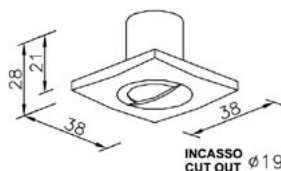

Luce di cortesia a LED da incasso

Fabbricata in Aisi 316 e corpo in plastica. Montaggio con viti.

Recessed mounting LED courtesy light

Manufactured in Aisi 316 and plastic body. Screws mounting.

| Articolo - Item | €/pc. | Power | Voltage | Light Source | Colour | Lumen | Max intensity CD | Beam Angle | Cut out mm. | CRI | IP |
|-----------------|-------|-------|----------|--------------|------------------|-------|------------------|------------|-------------|-----|----|
| L 44 05 028 | | 0,6W | 10-32VDC | 2835 SMD LED | Warm white 3000K | 8,2 | 13,6 | 25,5° | 19 | >80 | 65 |

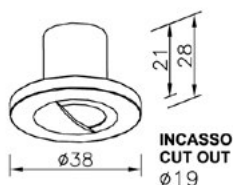

Luce di cortesia a LED da incasso

Fabbricata in Aisi 316 e corpo in plastica. Montaggio con viti.

Recessed mounting LED courtesy light

Manufactured in Aisi 316 and plastic body. Screws mounting.

| Articolo - Item | €/pc. | Power | Voltage | Light Source | Colour | Lumen | Max intensity CD | Beam Angle | Cut out mm. | CRI | IP |
|-----------------|-------|-------|----------|--------------|------------------|-------|------------------|------------|-------------|-----|----|
| L 44 04 038 | | 0,6W | 10-32VDC | 2835 SMD LED | Warm white 3000K | 15 | 19 | 66° | 19 | >80 | 65 |



Luce di cortesia a LED da incasso

Fabbricata in Aisi 316 e corpo in plastica. Montaggio con viti.

Recessed mounting LED courtesy light

Manufactured in Aisi 316 and plastic body. Screws mounting.

| Articolo - Item | €/pc. | Power | Voltage | Light Source | Colour | Lumen | Max intensity CD | Beam Angle | Cut out mm. | CRI | IP |
|-----------------|-------|-------|----------|--------------|------------------|-------|------------------|------------|-------------|-----|----|
| L 44 03 038 | | 0,6W | 10-32VDC | 2835 SMD LED | Warm white 3000K | 17 | 20 | 65° | 19 | >80 | 65 |

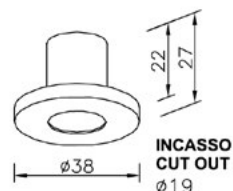

Luce di cortesia a LED da incasso

Fabbricata in Aisi 316 e plastica bianca.

Recessed mounting LED courtesy light

Manufactured in Aisi 316 and white plastic.

| Articolo - Item | €/pc. | Power | Voltage | Light Source | Colour | Lumen | Max intensity CD | Beam Angle | Cut out mm. | CRI | IP |
|-----------------|-------|-------|----------|--------------|------------------|-------|------------------|------------|-------------|-----|----|
| L 44 13 005 | | 0,2W | 10-32VDC | 2835 SMD LED | Warm white 3000K | 10 | 15 | 180° | 18 | >80 | 67 |



PLAFONIERE A LED «AURORA» | «AURORA» LED CEILING LIGHTS

LUCI INTERNO ED ESTERNO | INDOOR & OUTDOOR LIGHTING



Plafoniera a LED da incasso

Fabbricata in Aisi 316 e corpo in alluminio. Montaggio con viti.

Recessed mounting LED ceiling light

Manufactured in Aisi 316 and aluminium body. Screws mounting.

| Articolo - Item | €/pc. | Power | Voltage | Light Source | Colour | Lumen | Max intensity CD | Beam Angle | Cut out mm. | CRI | IP |
|-----------------|-------|-------|----------|--------------|------------------|-------|------------------|------------|-------------|-----|----|
| L 44 04 016 | | 1,3W | 10-32VDC | 3030 SMD LED | Warm white 3000K | 58 | 259 | 23,1° | 30 | >80 | 65 |



Plafoniera a LED da incasso

Fabbricata in Aisi 316 e corpo in alluminio. Montaggio con viti.

Recessed mounting LED ceiling light

Manufactured in Aisi 316 and aluminium body. Screws mounting.

| Articolo - Item | €/pc. | Power | Voltage | Light Source | Colour | Lumen | Max intensity CD | Beam Angle | Cut out mm. | CRI | IP |
|-----------------|-------|-------|----------|--------------|------------------|-------|------------------|------------|-------------|-----|----|
| L 44 16 020 | | 1,3W | 10-32VDC | 3030 SMD LED | Warm white 3000K | 76,8 | 434 | 23,5° | 31 | >80 | 65 |



Plafoniera a LED da incasso

Fabbricata in Aisi 316 e corpo in alluminio. Montaggio con viti.

Recessed mounting LED ceiling light

Manufactured in Aisi 316 and aluminium body. Screws mounting.

| Articolo - Item | €/pc. | Power | Voltage | Light Source | Colour | Lumen | Max intensity CD | Beam Angle | Cut out mm. | CRI | IP |
|-----------------|-------|-------|----------|--------------|------------------|-------|------------------|------------|-------------|-----|----|
| L 44 01 041 | | 1,5W | 10-32VDC | 3030 SMD LED | Warm white 3000K | 110 | 588 | 21,4° | 26 | >80 | 65 |

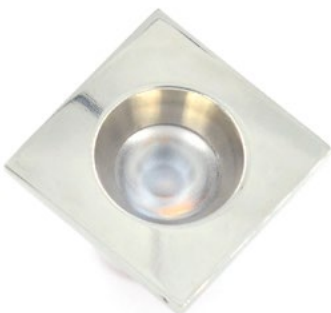
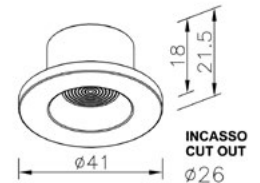

Plafoniera a LED da incasso

Fabbricata in Aisi 316 e corpo in alluminio. Montaggio con viti.

Recessed mounting LED ceiling light

Manufactured in Aisi 316 and aluminium body. Screws mounting.

| Articolo - Item | €/pc. | Power | Voltage | Light Source | Colour | Lumen | Max intensity CD | Beam Angle | Cut out mm. | CRI | IP |
|-----------------|-------|-------|----------|--------------|------------------|-------|------------------|------------|-------------|-----|----|
| L 44 02 036 | | 1,5W | 10-32VDC | 3030 SMD LED | Warm white 3000K | 106 | 618 | 20,4° | 26 | >80 | 65 |

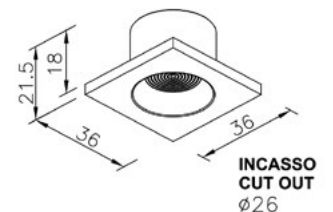

PLAFONIERE A LED «AURORA» | «AURORA» LED CEILING LIGHTS

Plafoniera a LED da incasso

Fabbricata in Aisi 316L e corpo in fusione di alluminio.

Recessed mounting LED ceiling light

Manufactured in Aisi 316L and die-cast aluminium body.

| Articolo - Item | €/pc. | Power | Voltage | Light Source | Colour | Lumen | Max intensity CD | Beam Angle | Cut out mm. | CRI | IP |
|-----------------|-------|-------|----------|--------------|-------------|-------|------------------|------------|-------------|-----|----|
| L 44 08 020 | | 3,6W | 10-32VDC | 3030 SMD LED | White 3000K | 237 | 113 | 87,4° | 55 | >80 | 65 |

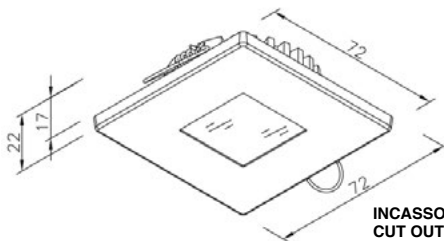

INCASSO
CUT OUT
Ø 55



Plafoniera a LED da incasso

Fabbricata in Aisi 316L e corpo in fusione di alluminio.

Recessed mounting LED ceiling light

Manufactured in Aisi 316L and die-cast aluminium body.

| Articolo - Item | €/pc. | Power | Voltage | Light Source | Colour | Lumen | Max intensity CD | Beam Angle | Cut out mm. | CRI | IP |
|-----------------|-------|-------|----------|--------------|-------------|-------|------------------|------------|-------------|-----|----|
| L 44 07 020 | | 3,6W | 10-32VDC | 3030 SMD LED | White 3000K | 250 | 107 | 95,5° | 55 | >80 | 65 |

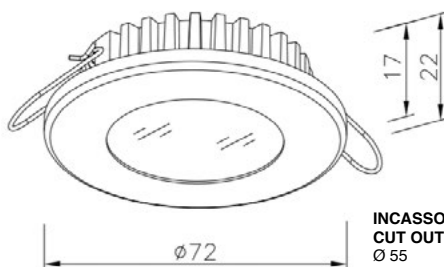

INCASSO
CUT OUT
Ø 55



Plafoniera a LED da incasso

Fabbricata in Aisi 316 e corpo in alluminio.

Recessed mounting LED ceiling light

Manufactured in Aisi 316 and aluminium body.

| Articolo - Item | €/pc. | Power | Voltage | Light Source | Colour | Lumen | Max intensity CD | Beam Angle | Cut out mm. | CRI | IP |
|-----------------|-------|-------|----------|--------------|-------------|-------|------------------|------------|-------------|-----|----|
| L 44 27 079 | | 4,0W | 10-32VDC | OSRAM | White 3000K | 344 | 163 | 97° | 54 | >80 | 20 |

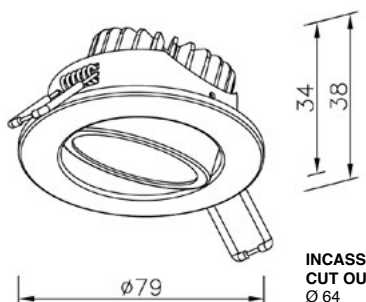

INCASSO
CUT OUT
Ø 64



Plafoniera a LED da appoggio

Fabbricata in Aisi 316L e corpo in alluminio. Montaggio con viti.

Flush mounting LED ceiling light

Manufactured in Aisi 316L and aluminium body. Screws mounting.

| Articolo - Item | €/pc. | Power | Voltage | Light Source | Colour | Lumen | Max intensity CD | Beam Angle | CRI | IP |
|-----------------|-------|-------|----------|--------------|------------------|-------|------------------|------------|-----|----|
| L 44 11 026 | | 3,6W | 10-32VDC | 3030 SMD LED | Warm white 3000K | 260 | 114 | 95° | >80 | 65 |

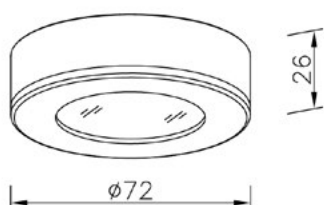



Lampada da carteggio a LED

Provvista di braccio flessibile.

LED chart light

With articulated bracket.

| Articolo - Item | €/pc. | Volts | Watt | LED | Lunghezza Length cm. | Light | Colore luce Light colour | kg. |
|-----------------|-------|-------|------|-----|-------------------------|-------|-----------------------------|-------|
| L 44 08 060 | | 12 | 1,0 | 1 | 50 | 12V | Bianco-White | 0,200 |

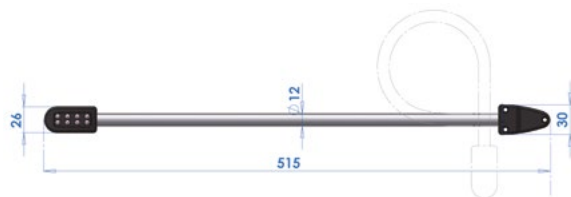

Faretto da lettura a LED

Fabbricato in alluminio cromato.
Interruttore Touch (Dimmer).

LED reading light

Manufactured in chromed aluminium.
Equipped with touch switch (Dimmer).

| Articolo - Item | €/pc. | Volts | Watt | Lumen | K | LED | Colore luce Light colour |
|-----------------|-------|-------|------|-------|-----------|-----|-----------------------------|
| L 44 12 022 | | 10-30 | 3,0 | 200 | 2800-3200 | 1 | Bianco-White |

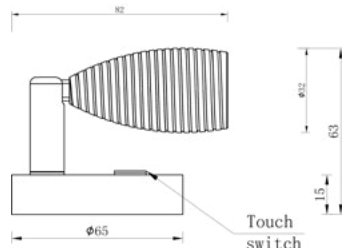

Faretto da lettura a LED

Fabbricato in alluminio.
Led con rotazione a 360°.
Colore bianco luce calda.

LED reading light

Manufactured in aluminium.
Revolving LED 360°.
Warm white light.

| Articolo - Item | €/pc. | Volts | Watt | LED | Interruttore Switch |
|-----------------|-------|-------|------|-----|------------------------|
| L 44 01 193 | | 12 | 0,5 | 6 | SI-YES |

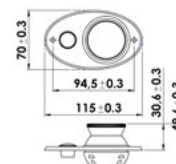

Faretto orientabile a LED

Fabbricato in alluminio.

Adjustable LED spotlight

Manufactured in aluminium.

| Articolo - Item | €/pc. | Volts | Watt | LED | Ø mm. | H mm. | Colore luce Light colour |
|-----------------|-------|-------|------|-----|-------|-------|-----------------------------|
| L 44 00 214 | | 12 | 1,0 | 1 | 54 | 31 | Bianco-White |

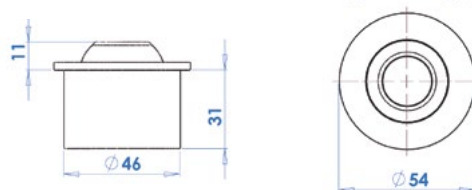

Plafoniera a LED 12V con accensione a pressione del vetro

Fabbricata in plastica.

12V LED ceiling light with lighting by glass pressure

Manufactured in plastic.

| Articolo - Item | €/pc. | Volts | Watt | LED | mm. | Colore luce Light colour |
|-----------------|-------|-------|------|-----|--------|-----------------------------|
| L 44 00 075 | | 12 | 3,0 | 6 | 138x92 | Bianco-White |

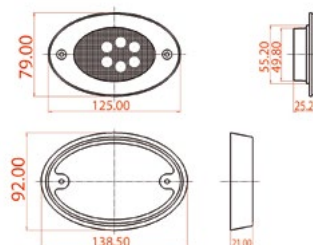

Faretto a LED con accensione a sensore

Fabbricata in plastica bianca.

LED sensor spotlight

Manufactured in white plastic.

| Articolo - Item | €/pc. | Volts | Watt | LED | Colore luce Light colour | kg. |
|-----------------|-------|-------|------|-----|-----------------------------|-------|
| L 44 74 239 | | 12 | 1,0 | 1 | Bianco caldo Warm white | 0,040 |



Faretto a LED

Montaggio in superficie
Corpo in plastica bianca.
Modello a 3 LED e 2 LED a 3 colori:
(rosso, giallo, blu).

LED spotlight

Flush mounting.
White plastic body.
3 LED model and 2 LED with 3 colours:
(red, yellow, blue).

| Articolo - Item | €/pc. | Volts | Watt | LED | Colore luce Light colour |
|-----------------|-------|-------|------|-----|---|
| L 44 00 191 | | 12 | 1,0 | 3 | Rosso-Bianco caldo-Blu Red-Warm white-Blue |



Lampada a LED

Fabbricata in ABS.

LED light

Manufactured in ABS.

| Articolo - Item | €/pc. | Colore Colour | Volts | mm. | Lunghezza cavo Cable length mm. | Colore luce Light colour | kg. |
|-----------------|-------|------------------|-------|------------|------------------------------------|-----------------------------|-------|
| L 44 38 170 | | | 12 | 170x30x38H | 2000 | Bianco-White | 0,070 |

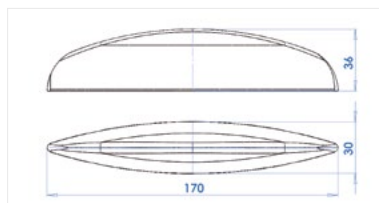

Plafoniera quadrata a LED con interruttore

Realizzata in materiale plastico.
Interruttore 2 posizioni OFF - ON -accesa a metà.

LED square ceiling light with switch

Manufactured in plastic.
2-positions switch.

| Articolo - Item | €/pc. | Colore Colour | Volts | LED | Colore luce Light colour | kg. |
|-----------------|-------|------------------|-------|-----|-----------------------------|-------|
| L 44 01 557 | | | 12 | 36 | Bianco-White | 0,300 |

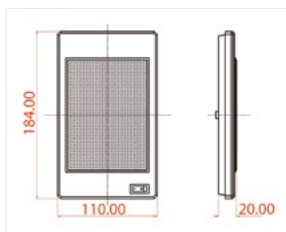

Lampada da interni a LED

Fabbricata in plastica bianca. LED colore bianco naturale. Modello con interruttore a sensibilità tattile.

LED interior light

Manufactured in white plastic. Nature white LED. Equipped with touch switch (dimnable).

| Articolo - Item | €/pc. | Volts | Watt | LED | Lumen | Lunghezza Length mm. | Colore luce Light colour |
|-----------------|-------|-------|------|-----|-------|-------------------------|-----------------------------|
| L 44 02 768 | | 10-30 | 12,0 | 12 | 950 | 136 | Bianco-White |
| L 44 02 769 | | 10-30 | 18,0 | 18 | 1350 | 186 | Bianco-White |

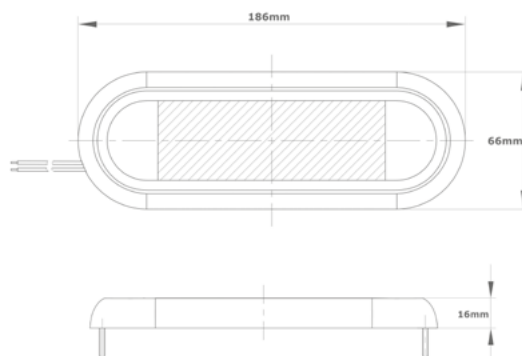
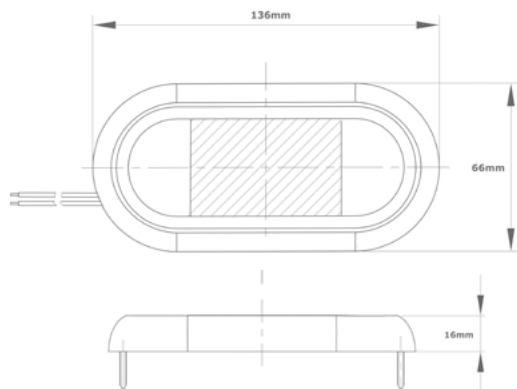



Plafoniera a LED da incasso

Fabbricata in Aisi 316.

Recessed mounting LED light

Manufactured in Aisi 316.

| Articolo - Item | €/pc. | Volts | Watt | LED | Colore luce Light colour |
|-----------------|-------|-------|------|-----|-----------------------------|
| L 44 32 358 | | 12 | 3,0 | 1 | Bianco-White |

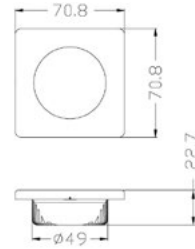

Plafoniera a LED da incasso

Fabbricata in alluminio.

Recessed mounting LED light

Manufactured in aluminium.

| Articolo - Item | €/pc. | Volts | Watt | LED | Colore luce Light colour |
|-----------------|-------|-------|------|-----|-----------------------------|
| L 44 00 190 | | 12 | 3,0 | 1 | Bianco caldo Warm white |

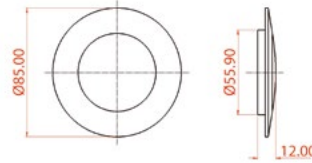

Plafoniera a LED da appoggio

Con coperchio in plastica.

Flush mounting LED light

With plastic cover.

| Articolo - Item | €/pc. | Volts | Watt | LED | Colore luce Light colour |
|-----------------|-------|-------|------|-----|-----------------------------|
| L 44 00 213 | | 12 | 3,0 | 3 | Bianco caldo Warm white |

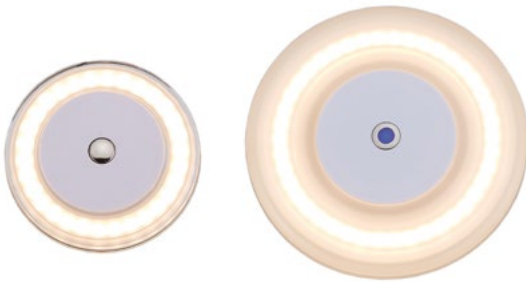
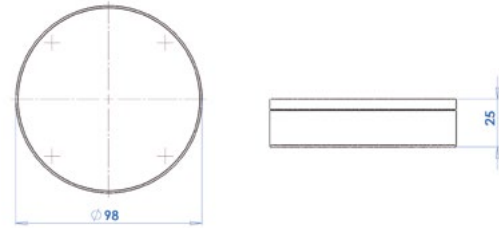

Plafoniera a LED

Fabbricata in plastica.
Interruttore Touch (Dimmer).

LED ceiling light

Manufactured in plastic.
Equipped with touch switch (Dimmer).

| Articolo - Item | €/pc. | Volts | Watt | LED | Lumen | K | Colore luce Light colour |
|-----------------|-------|-------|------|-----|-------|-----------|-----------------------------|
| L 44 74 263 | | 9-16 | 3,0 | 30 | 300 | 2800-3200 | Bianco-White |
| L 44 74 264 | | 9-16 | 6,0 | 42 | 500 | 2800-3200 | Bianco-White |

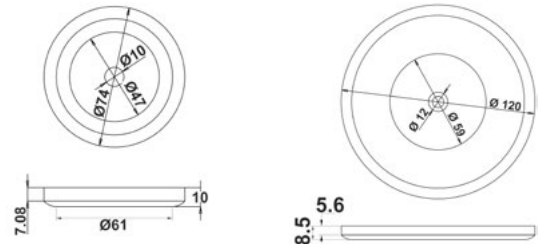

Plafoniera a LED

Fabbricata in alluminio cromato.

LED ceiling light

Manufactured in chromed aluminium.

| Articolo - Item | €/pc. | Ø mm. | H mm. | Volts | Watt | LED | Lumen | K | Interruttore Switch | Colore luce Light colour |
|-----------------|-------|-------|-------|----------|------|-----|-------|------|------------------------|-----------------------------|
| L 44 00 252 | | 74 | 7 | 10-30VDC | 5,0 | 27 | 343 | 3000 | NO | Bianco-White |
| L 44 00 253 | | 120 | 8 | 10-30VDC | 8,0 | 42 | 558 | 3000 | TOUCH | Bianco-White |



Plafoniera a LED senza incasso

Recessless LED ceiling light

Corpo in acciaio inox lucidato a specchio.

Body in mirror polished stainless steel.

| Articolo - Item | €/pc. | Ø mm. | Volts | Watt | Lumen | K | Angolo LED LED Angle | LED | Colore luce Light colour |
|-----------------|-------|-------|-------|------|-------|-----------|-------------------------|-----|-----------------------------|
| L 44 05 070 | | 94 | 12 | 3,0 | 84 | 2900-3200 | 25° | 5 | Bianco-White |
| L 44 06 070 | | 110 | 12 | 3,2 | 108 | 2900-3200 | 25° | 6 | Bianco-White |
| L 44 09 070 | | 132 | 12 | 5,0 | 162 | 2900-3200 | 25° | 9 | Bianco-White |

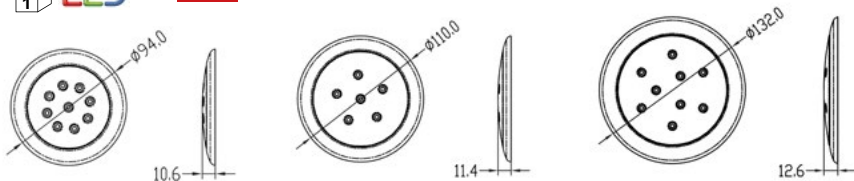

Plafoniera senza incasso a LED

Recessless LED ceiling light

Corpo in ABS, lente in vetro satinato.
Versione ultrapiatta con interruttore Touch e due livelli di luminosità.
Finitura cromata.

ABS body, satin-finish glass.
Ultra-flat version with touch switch and two light levels.
Chrome plated finishing.

| Articolo - Item | €/pc. | Volts | Watt | Lumen | K | Angolo LED LED Angle | LED | Colore luce Light colour |
|-----------------|-------|-------|------|-------|-----------|-------------------------|------------|-----------------------------|
| L 44 04 609 | | 12/24 | 3,0 | 168 | 3050-3800 | 120° | 42 LED SMD | Bianco-White |

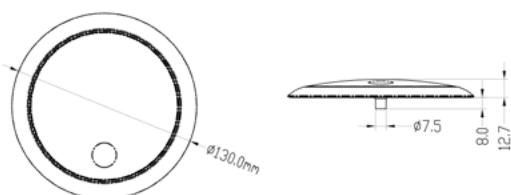

Plafoniera a LED senza incasso

Recessless LED ceiling light

Finitura lucida.

Polished finish.

| Articolo - Item | €/pc. | Ø mm. | Volts | Watt | Lumen | K | LED | Colore luce Light colour |
|-----------------|-------|-------|-------|------|-------|------|-----|-----------------------------|
| L 44 32 601 | | 94 | 12 | 3,2 | 100 | 3500 | 16 | Bianco-White |
| L 44 28 602 | | 132 | 12 | 5,6 | 110 | 3500 | 28 | Bianco-White |

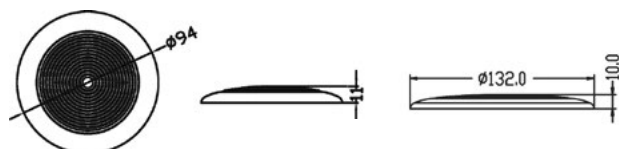

Plafoniera a LED senza incasso accensione a sensore

Recessless sensor switch LED ceiling light

Corpo in acciaio inox lucidato a specchio.

Body in mirror polished stainless steel.

| Articolo - Item | €/pc. | Volts | Watt | Lumen | K | Angolo LED LED Angle | LED | Colore luce Light colour |
|-----------------|-------|-------|------|-------|-----------|-------------------------|-----|-----------------------------|
| L 44 74 601 | | 12 | 2,5 | 207 | 2900-3200 | 25° | 16 | Bianco-White |

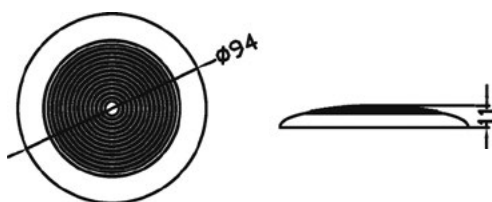

Plafoniera a LED senza incasso

Recessless LED ceiling light

Fabbricata in plastica.

Manufactured in plastic.

| Articolo - Item | €/pc. | Finitura Plastic | Volts | Watt | Lumen | K | LED |
|-----------------|-------|---------------------|-------|------|-------|-----------|-------------------------------|
| L 44 10 608 | | Plastica Plastic | 12 | 6,0 | 390 | 2900-3200 | 30 Bianchi-White +26 Blu-Blue |

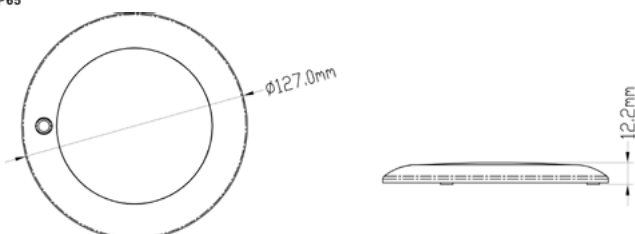



Plafoniera a LED

Fabbricata in acciaio inox.

LED ceiling light

Manufactured in stainless steel.

| Articolo - Item | €/pc. | Volts | Watt | LED | Lumen | Colore luce Light colour |
|-----------------|-------|-------|------|-----|-------|-----------------------------|
| L 44 00 553 | | 12 | 4,5 | 24 | 250 | Bianco-White |

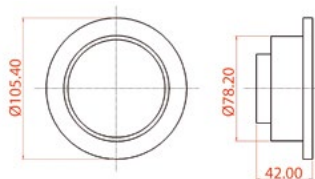

Plafoniera tonda a LED

Fabbricata in alluminio.
Modello inclinabile.

Round LED ceiling light

Manufactured in aluminium.
Tilting model.

| Articolo - Item | €/pc. | Volts | Watt | LED | Colore luce Light colour |
|-----------------|-------|-------|------|-----|-----------------------------|
| L 44 00 217 | | 12 | 6,0 | 6 | Bianco-White |

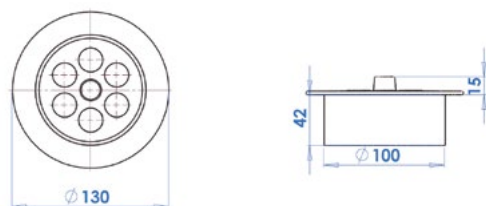

Plafoniera tonda a LED

Fabbricata in acciaio inox Aisi 316.

Round LED ceiling light

Manufactured in Aisi 316 stainless steel.

| Articolo - Item | €/pc. | Volts | Ø mm. | H mm. | LED |
|-----------------|-------|-------|-------|-------|----------------------------------|
| L 44 00 211 | | 12 | 52 | 22 | 4 Rossi-Red + 8 Bianchi-White |

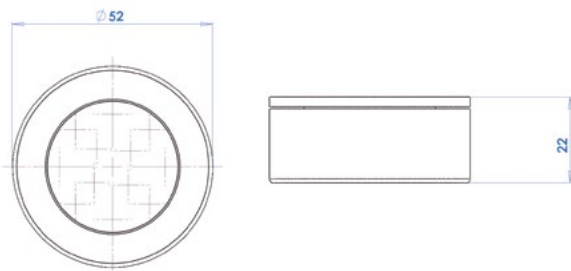

Plafoniera da appoggio e incasso a LED

Fabbricata in acciaio inox Aisi 316.

Flush and recessed mounting LED ceiling light

Manufactured in Aisi 316 stainless steel.

| Articolo - Item | €/pc. | Volts | Watt | LED | Colore luce Light colour |
|-----------------|-------|-------|------|-----|-----------------------------|
| L 44 32 158 | | 12 | 3,0 | 1 | Bianco-White |

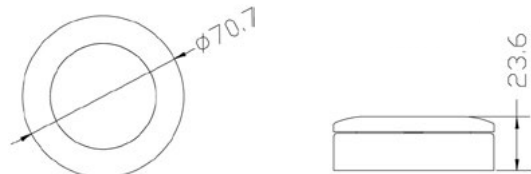

Plafoniera da appoggio a LED con interruttore

Fabbricata in ABS.

Flush mounting LED light with switch

Manufactured in ABS.

| Articolo - Item | €/pc. | Volts | Watt | LED | Lumen | K | Colore luce Light colour |
|-----------------|-------|-------|------|-----|-------|-----------|-----------------------------|
| L 44 12 553 | | 12DC | 4,4 | 24 | 328 | 2900-3200 | Bianco-White |

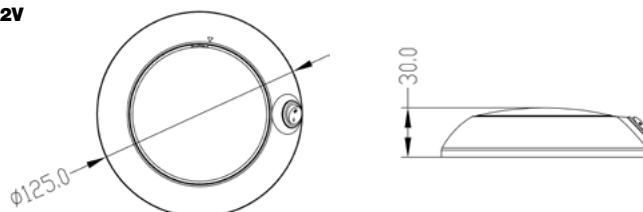

Plafoniera a LED

Fabbricata in alluminio. Orientabile a 270°. Base 21x16 mm. Con interruttore.

LED ceiling light

Manufactured in aluminium. Tilting 270°. Base 21x16 mm. With switch.

| Articolo - Item | €/pc. | Volts | Watt | LED | Colore luce Light colour | kg. |
|-----------------|-------|-------|------|-----|--------------------------|-------|
| L 44 20 290 | | 12 | 10,0 | 18 | Bianco-White | 0,120 |



Plafoniera a LED

Fabbricata in ABS. Orientabile a 180°. Applicabile in qualsiasi posizione. Con interruttore.

LED ceiling light

Manufactured in ABS. Tilting 180°. Can be fitted in any position. With switch.

| Articolo - Item | €/pc. | Volts | Watt | LED | Colore luce Light colour | kg. |
|-----------------|-------|-------|------|-----|--------------------------|-------|
| L 44 09 280 | | 12 | 2,0 | 6 | Bianco-White | 0,160 |

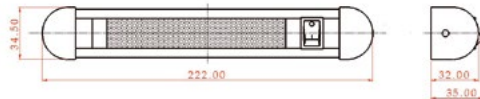

Plafoniera a LED

Fabbricata in ABS. Dotata di pulsante nero ON-OFF.

LED ceiling light

Manufactured in ABS. Black switch ON-OFF.

| Articolo - Item | €/pc. | Volts | Watt | LED | Colore luce Light colour |
|-----------------|-------|-------|------|-----|--------------------------|
| L 44 01 804 | | 10-30 | 12,0 | 12 | Bianco-White |

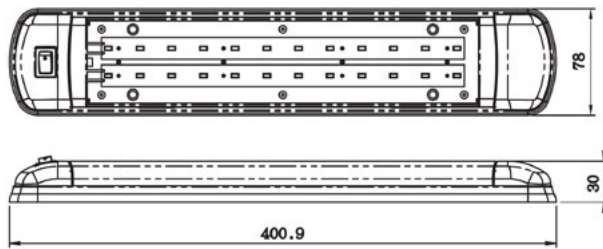

Plafoniera a LED

Fabbricata in plastica.

LED ceiling light

Manufactured in plastic.

| Articolo - Item | €/pc. | Volts | Watt | LED | Colore luce Light colour |
|-----------------|-------|-------|------|-----|--------------------------|
| L 44 00 231 | | 12 | 6,0 | 2 | Bianco-White |

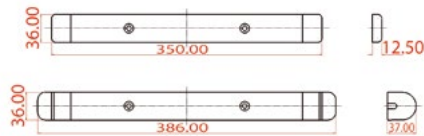

Plafoniera a LED

Fabbricata in plastica. Interruttore Touch Switch.

LED ceiling light

Manufactured in plastic. Touch Switch.

| Articolo - Item | €/pc. | Volts | Watt | Lumen | LED | Colore luce Light colour |
|-----------------|-------|-------|------|-------|-----|--------------------------|
| L 44 22 077 | | 10-30 | 4,4 | 185 | 22 | Bianco-White |
| L 44 54 077 | | 10-30 | 10,8 | 515 | 54 | Bianco-White |

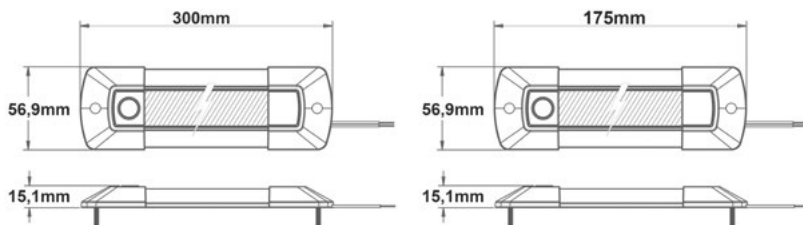



Luce di cortesia ovale a LED

LED oval courtesy light

| Articolo - Item | €/pc. | Volts | Colour | K | Watt | LED | kg. |
|-----------------|-------|-------|--------|------|------|-----|-------|
| L 44 03 007 | | 12 | white | 3000 | 0,4 | 3 | 0,040 |



Luce a LED montaggio al piano

Flush mounting LED light

Fabbricata in plastica.

Manufactured in plastic.

| Articolo - Item | €/pc. | Volts | Colour | K | Watt | LED |
|-----------------|-------|-------|--------|------|------|-----|
| L 44 00 183 | | 12 | white | 3000 | 0,6 | 6 |

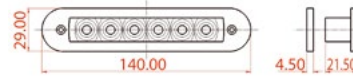

Luce di cortesia a LED

LED courtesy light

Fabbricata in acciaio inox.

Manufactured in stainless steel.

| Articolo - Item | €/pc. | Volts | Watt | LED | Colore luce Light colour | Mod. |
|-----------------|-------|-------|------|-----|-----------------------------|--------------------------------------|
| L 44 12 751 | | 12 | 1,0 | 9 | Bianco caldo Warm white | Luce verso il basso Down light |
| L 44 12 753 | | 12 | 1,0 | 9 | Bianco caldo Warm white | Luce alto e basso Up & down light |

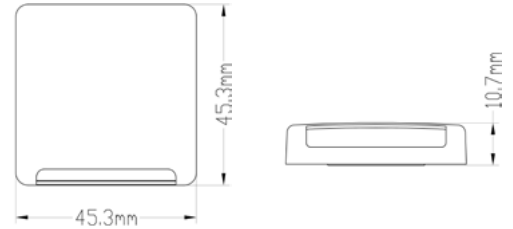

Luce di cortesia a LED senza incasso

Recessless LED courtesy light

Finitura cromata.
Fissaggio tramite viti invisibili.
Dimensioni:
• Esterno 80x18 mm.
• Sporgenza 15,8 mm.

Chrome plated finishing.
Fastening by invisible screws.
Size:
• Outside 80x18 mm.
• Overhang 15,8 mm.

| Articolo - Item | €/pc. | Volts | Watt | LED | Lumen | K | Angolo LED LED Angle | Colore luce Light colour |
|-----------------|-------|-------|------|-----|-------|-----------|-------------------------|-----------------------------|
| L 44 00 181 | | 12 | 0,4 | 5 | 30 | 2900-3200 | 120° | Bianco-White |

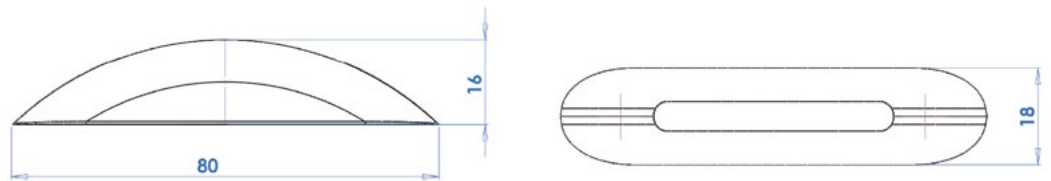

Luce di cortesia a LED con coperchio

LED courtesy light with cover

Fabbricata in acciaio inox Aisi 316.

Manufactured in Aisi 316 stainless steel.

| Articolo - Item | €/pc. | Volts | Watt | LED | Lumen | K | Colore luce Light colour |
|-----------------|-------|-------|------|-----|-------|------|-----------------------------|
| L 44 74 262 | | 12 | 0,4 | 2 | 28 | 6300 | Bianco-White |
| L 44 75 262 | | 12 | 0,4 | 2 | 5 | - | Blu-Blue |

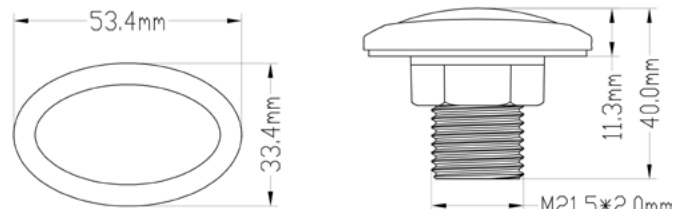

Luce di cortesia a LED da incasso

Recessed mounting LED courtesy light

Fabbricata in policarbonato trasparente.

Manufactured in transparent Polycarbonate.

| Articolo - Item | €/pc. | Volts | Watt | Lumen | K | Angolo LED LED Angle | LED | Colore luce Light colour | kg. |
|-----------------|-------|-------|------|-------|-----------|-------------------------|-----|-----------------------------|-------|
| L 44 74 910 | | 12 | 0,2 | 12,5 | 5500-6300 | 120° | 1 | Bianco-White | 0,040 |
| L 44 75 910 | | 12 | 0,2 | 2 | - | 120° | 1 | Blu-Blue | 0,040 |

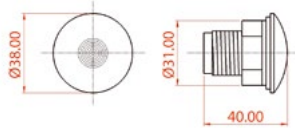

Luce di cortesia a LED da incasso

Recessed mounting LED courtesy light

Fabbricata in tecnopolimero con palpebra di acciaio inox Aisi 316 lucidato.

Manufactured in technopolymer with polished Aisi 316 stainless steel cover.

| Articolo - Item | €/pc. | Volts | Watt | Lumen | K | Angolo LED LED Angle | LED | Colore luce Light colour | kg. |
|-----------------|-------|-------|------|-------|------|-------------------------|-----|-----------------------------|-----|
| L 44 74 062 | | 12 | 0,4 | 21 | 5500 | 120° | 2 | Bianco-White | |
| L 44 75 062 | | 12 | 0,4 | 4 | - | 120° | 2 | Blu-Blue | |

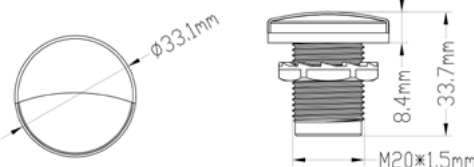

Luce di cortesia a LED da incasso

Recessed mounting LED courtesy light

Corpo in plastica bianca, frontale in acciaio inox lucidato a specchio. Montaggio a scatto.

Body manufactured in white plastic, mirror-polished stainless steel front panel. Snap mounting.

| Articolo - Item | €/pc. | Volts | Watt | Lumen | K | Angolo LED LED Angle | LED | Colore luce Light colour | kg. |
|-----------------|-------|--------|------|-------|------|-------------------------|-----|-----------------------------|-----|
| L 44 74 360 | | 12//24 | 0,5 | 25 | 3000 | 360° | 6 | Bianco-White | |
| L 44 75 360 | | 12//24 | 0,5 | 10 | - | 360° | 6 | Blu-Blue | |
| L 44 74 180 | | 12//24 | 0,5 | 25 | 3000 | 180° | 6 | Bianco-White | |
| L 44 75 180 | | 12//24 | 0,5 | 10 | - | 180° | 6 | Blu-Blue | |

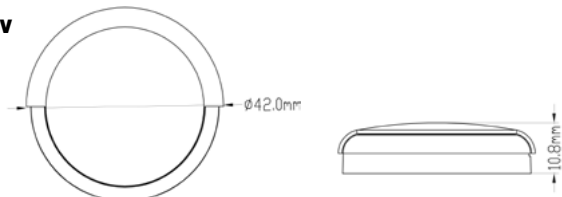

Luce di cortesia a LED senza incasso

Recessless LED courtesy light

Fabbricata in plastica bianca.
Dimensioni:
• 70x38x Sporgenza 10 mm.

Manufactured in white plastic.
Size:
• Outside 70x38x Overhang 10 mm.

| Articolo - Item | €/pc. | Volts | Watt | Lumen | K | Angolo LED LED Angle | LED | Colore luce Light colour | kg. |
|-----------------|-------|-------|------|-------|-----------|-------------------------|-----|-----------------------------|-------|
| L 44 74 182 | | 12 | 0,4 | 38 | 2900-3200 | 120° | 5 | Bianco-White | 0,030 |
| L 44 75 182 | | 12 | 0,4 | 11,4 | - | 120° | 5 | Blu-Blue | 0,030 |

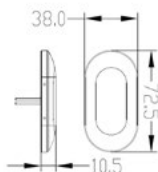

Luce di cortesia a LED senza incasso

Recessless LED courtesy light

Frontale in acciaio inox lucidato a specchio.
Dimensioni:
• Esterno 72,5x38 mm.
• Sporgenza 10,5 mm.

Mirror-polished stainless steel front panel.
Size:
• Outside 72,5x38 mm.
• Overhang 10,5 mm.

| Articolo - Item | €/pc. | Volts | Watt | Lumen | K | Angolo LED LED Angle | LED | Colore luce Light colour | kg. |
|-----------------|-------|-------|------|-------|-----------|-------------------------|-----|-----------------------------|-----|
| L 44 74 767 | | 12 | 1,2 | 83 | 5500-6300 | 120° | 6 | Bianco-White | |
| L 44 75 767 | | 12 | 1,2 | 22 | - | 120° | 6 | Blu-Blue | |

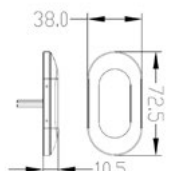

LUCI DI CORTESIA A LED | LED COURTESY LIGHTS

13



Luca di cortesia a LED

Fabbricata in policarbonato.
Montaggio a incasso.

Articolo - Item €/pc. Volts Watt LED
L 44 00 189 12 0,5 1



Flush mounting LED light

Manufactured in polycarbonate.
Flush-mounting.

Colore luce Light colour ↑ mm. kg.
Bianco-White 45x31

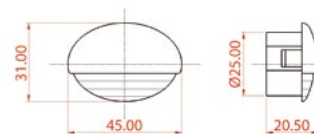

Luca a LED montaggio al piano

Fabbricata in plastica.

Articolo - Item €/pc. Volts Watt LED
L 44 00 193 12 1,0 6



Flush mounting LED light

Manufactured in plastic.

Colore luce Light colour ↑ mm. kg.
Bianco-White 140x17x24H 0,060

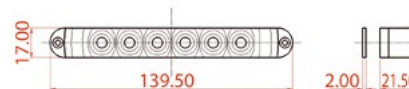

Luca a LED multiuso

Colore bianco. Resistente all'acqua.

Articolo - Item €/pc. Volts Watt LED
L 44 91 025 12 0,03 6



Multipurpose LED light

White colour. Water resistant.

Colore luce Light colour ↑ mm. kg.
Bianco-White 95x15 0,040

LUCI DA ESTERNO A LED | OUTDOOR LED LIGHTS



Plafoniera Push On 16 LED da incasso

Corpo in plastica bianca.
Si aziona premendo la lente.

Articolo - Item €/pc. Volts Watt LED Lumen K
L 44 74 165 12 1,5 16 230 4500



Recessed mounting Push On 16 LED ceiling light

Body in white plastic.
It is activated by pressing the glass.

Colore luce Light colour Ø mm. H mm. kg.
Bianco-White 110 44 0,120

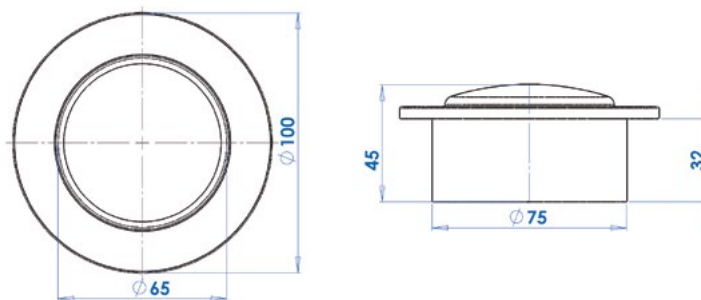

Plafoniera Push On 16 LED fissaggio in superficie

Corpo in plastica bianca.
Si aziona premendo la lente.

Articolo - Item €/pc. Volts Watt LED Lumen K
L 44 74 166 12 1,5 16 230 4500



Flush mounting Push On 16 LED light

Body in white plastic.
It is activated by pressing the glass.

Colore luce Light colour Ø mm. H mm. kg.
Bianco-White 100 30 0,140

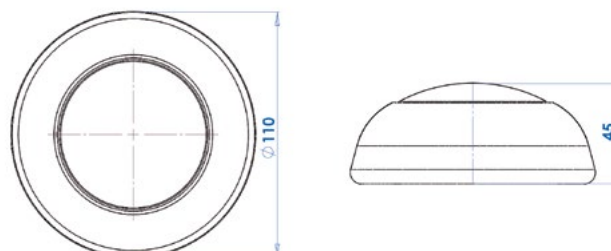

Luce da incasso per pozzetto

Resistente agli spruzzi.

Recessed mounting cockpit light

Waterproof.

| Articolo - Item | €/pc. | Volts | Watt | LED | K | Colore luce Light colour | Ø est. mm. Outer Ø mm. | Incasso Recess Ø mm. | H mm. | kg. |
|-----------------|-------|-------|------|-----|------|-----------------------------|---------------------------|-------------------------|----------|-------|
| L 44 91 054 | | 9-32 | 9,8 | 8 | 4500 | Bianco-White | 150 | 115 | 45 | 0,415 |

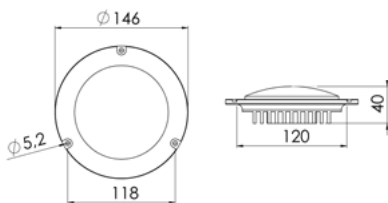
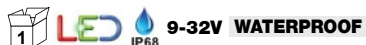

Luce stagna con lente in plexiglass trasparente fissaggio in superficie

Particolarmente adatta per illuminazione vani motore, gavoni o pozzetto.

Watertight light with transparent plexiglass flush mounting

Particularly suitable for lighting engine rooms, peaks or cockpit.

| Articolo - Item | €/pc. | Volts | Watt | LED | K | Colore vetro Glass colour | kg. |
|-----------------|-------|-------|------|-----|------|------------------------------|-------|
| L 44 18 606 | | 12 | 2,0 | 5 | 6500 | Bianco-White | 0,500 |

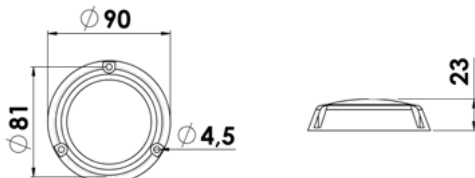

Luce stagna da incasso per pozzetto

Completamente stagna, con lente in plexiglass trasparente molto robusto, si incassa nelle paratie del pozzetto o del Fly Bridge. Adatta anche come luce di banchina per essere incassata sulla poppa. Può essere usata come luce subacquea in vasche o piscine. Prodotto in Luran resistente UV.

Watertight recessed mounting cockpit light

100% watertight, fitted with very sturdy plexiglass clear lens, designed for mounting on the cockpit bulkheads or on the flybridge. Also suitable as dock light for stern mounting and it may also be used as underwater light in tanks or pools. UV-resistant Luran body.

| Articolo - Item | €/pc. | Volts | Watt | LED | K | Colore vetro Glass colour | kg. |
|-----------------|-------|-------|------|-----|------|------------------------------|-------|
| L 44 18 607 | | 12 | 2,0 | 5 | 6500 | Bianco-White | 0,500 |

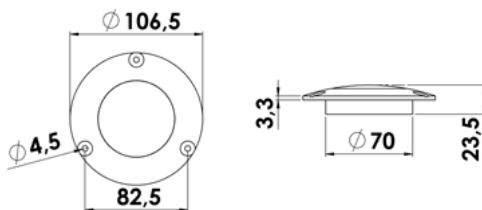

Luce «Star Lux»

Fabbricata in plastica con vetro in policarbonato. Per utilizzo da interno o da esterno.

«Star Lux» light

Manufactured in plastic material with Polycarbonate glass. Suitable for indoor and outdoor application.

| Articolo - Item | €/pc. | Volts | Watt | LED | Colore luce Light colour | kg. |
|-----------------|-------|-------|------|-----|-----------------------------|-------|
| L 44 24 666 | | 12 | 7,0 | 36 | Bianco-White | 0,530 |

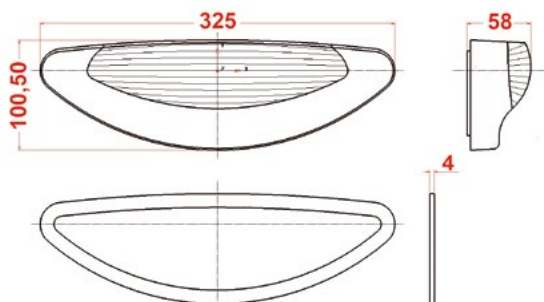



Lampada a LED da incasso a parete senza interruttore

Provvista di 3 LED a luce bianca. Basso consumo.

Recessed mounting LED light without switch

Supplied with 3 white LED. Low consumption.

| Articolo - Item | €/pc. | Volts | Watt | LED | Lumen | Colore luce Light colour | kg. |
|-----------------|-------|-------|------|-----|-------|-----------------------------|-------|
| L 44 00 158 | | 12 | 2,0 | 3 | 45 | Bianco-White | 0,050 |

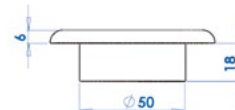
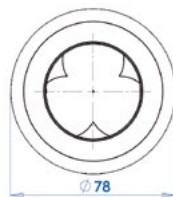

Faretto a LED senza interruttore

Corpo in plastica bianca. Montaggio da incasso o superficie. Provvista di 3 LED a luce bianca.

LED spotlight without switch

Body manufactured in white plastic. Flush or surface mounting. Supplied with 3 white LED.

| Articolo - Item | €/pc. | Volts | Watt | LED | Lumen | Colore luce Light colour | kg. |
|-----------------|-------|-------|------|-----|-------|-----------------------------|-------|
| L 44 02 358 | | 12 | 1,5 | 3 | 20 | Bianco-White | 0,060 |

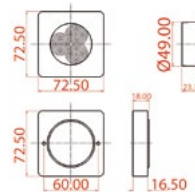

Faretto a LED

Corpo in plastica bianca. Montaggio da incasso o superficie. Luce bianca. Base in alluminio.

LED spotlight

Body manufactured in white plastic. Flush or surface mounting. White light. Aluminium base.

| Articolo - Item | €/pc. | Volts | Watt | LED | Lumen | Colore luce Light colour | kg. |
|-----------------|-------|-------|------|-----|-------|-----------------------------|-------|
| L 44 03 358 | | 12 | 2,0 | 3 | 45 | Bianco-White | 0,100 |

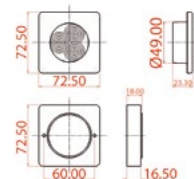

Faretto a LED

Corpo in plastica colore argento. Montaggio in superficie. Provvista di interruttore.

LED spotlight

Body manufactured in silver colour plastic. Surface mounting. With switch.

| Articolo - Item | €/pc. | Volts | Watt | LED | Lumen | Colore luce Light colour | kg. |
|-----------------|-------|-------|------|-----|-------|-----------------------------|-------|
| L 44 00 511 | | 12 | 4,0 | 20 | - | Bianco-White | 0,160 |

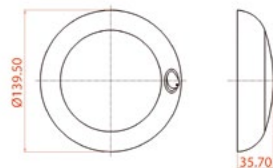

Faretto a LED da incasso

Corpo in alluminio a 3 fori. Luce bianca + Luce blu notturna.

Recessed mounting LED spotlight

Aluminium body with 3 holes. White light + Blue night light.

| Articolo - Item | €/pc. | Volts | Watt | LED | Colore luce Light colour | mm. | Foro-Hole Ø mm. | H after mounting mm. | kg. |
|-----------------|-------|-------|------|-----|-----------------------------|---------|--------------------|-------------------------|-------|
| L 44 22 065 | | 12 | 1,5 | 1 | White-blue | Ø65xH22 | 45 | 6 | 0,750 |



LED CALPESTABILI | WALKABLE LED



Serpentina calpestabile a LED

Provista di 60 led per metro. Possibilità di essere tagliata ogni 3 led. Involucro in plastica sigillato provvisto di bioadesivo per il fissaggio.

LED strip light

Supplied with 60 leds per meter. Possibility of cutting every 3 leds. Sealed plastic body with bioadhesive tape.

| Articolo - Item | €/ | Volts | LED | mt. | Colore-Colour | kg. |
|-----------------|----|-------|-----|-----|---------------|-------|
| L 44 03 528 | | 12 | 5 | | | 0,160 |



Applique snodata

Fabbricata in ottone cromato.
Provvista di interruttore.

| Articolo - Item | €/pc. | Lunghezza Length cm. | Light | Colore luce Light colour | kg. |
|-----------------|-------|----------------------|------------|--------------------------|-------|
| L 44 01 408 | | 35 | G4 12V 20W | Bianco-White | 0,340 |

12V

Articulated reading light

Manufactured in chromed brass.
Supplied with switch.



Applique snodata

Fabbricata in ottone cromato.
Provvista di interruttore.

| Articolo - Item | €/pc. | Light | Colore luce Light colour | kg. |
|-----------------|-------|------------|--------------------------|-------|
| L 44 00 943 | | G4 12V 20W | Bianco-White | 0,160 |

12V

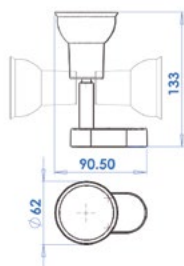

Articulated reading light

Manufactured in chromed brass.
Supplied with switch.



Lampada alogena da parete

Fabbricata in nylon.

| Articolo - Item | €/pc. | Light | Vetro-Glass | kg. |
|-----------------|-------|---------|-------------|-------|
| L 44 00 926 | | 12V 10W | | 0,170 |
| L 44 74 926 | | 12V 10W | | 0,160 |

12V

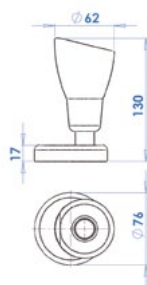

Halogen reading light

Manufactured in nylon.



L4474926

L4400926

Applique da parete

Fabbricata in policarbonato metallizzato.

| Articolo - Item | €/pc. | Mod. | Light | Colore luce Light colour | kg. |
|-----------------|-------|-----------------|---------|--------------------------|-------|
| L 44 00 939 | | Alogena-Halogen | 12V 10W | Bianco-White | 0,110 |
| L 44 12 939 | | LED | 12V 10W | Bianco-White | 0,110 |

12V

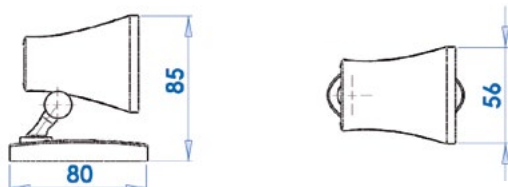

Reading light

Manufactured in metallized Polycarbonate .



Plafoniera in ottone cromato 12V ideale per il montaggio sotto il rollbar

Provvista di interruttore.

| Articolo - Item | €/pc. | Volts | Watt | Bulb | Colore luce Light colour | kg. |
|-----------------|-------|-------|------|------|--------------------------|-------|
| L 44 00 520 | | 12 | 10,0 | G4 | Bianco-White | 0,160 |

12V

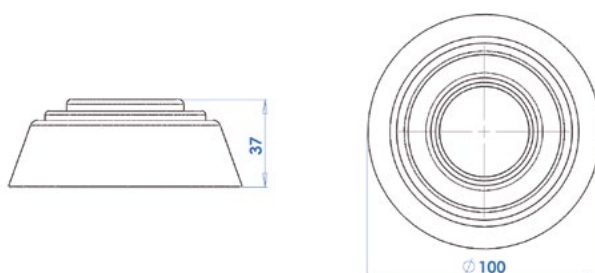

Brass ceiling light 12V suitable for fitting under the rollbar

With switch.





Plafoniera senza incasso

Lente in vetro punteggiato.
Finitura in acciaio inox.

Recessless ceiling light

Dotted glass diffuser.
Stainless steel finishing.

| Articolo - Item | €/pc. | Ø mm. | Volts | Watt | Interruttore Switch | Tipo lampadina Bulb type | Colore luce Light colour |
|-----------------|-------|-------|-------|------|---------------------|--------------------------|--------------------------|
| L 44 32 110 | | 109 | 12 | 15,0 | SI-YES | BA15D | Bianco-White |
| L 44 03 175 | | 137 | 12 | 15,0 | SI-YES | BA15D | Bianco-White |



12V

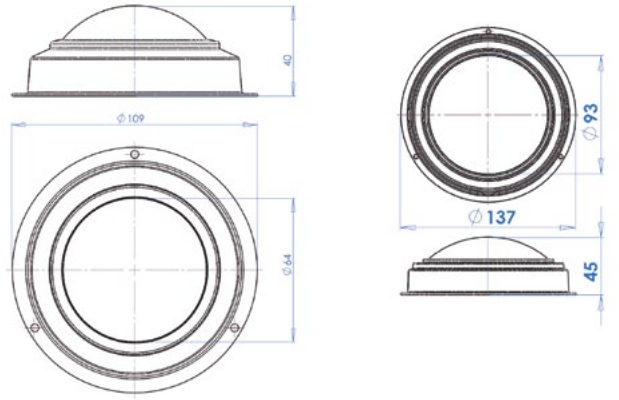

Faretto alogeno quadro

Fabbricata in ottone.
Vetro satinato.

Square halogen spotlight

Manufactured in brass.
Glazed glass.

| Articolo - Item | €/pc. | mm. | Light | Colore luce Light colour | kg. |
|-----------------|-------|-------|---------|--------------------------|-------|
| L 44 00 176 | | 85x85 | 12V 10W | Bianco-White | 0,170 |



12V

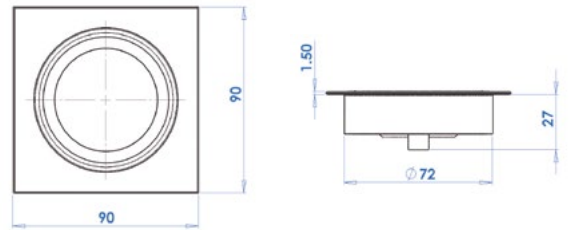

Plafoniera tonda

Fabbricata in acciaio smaltato.
Con lampadina alogena.

Round ceiling light

Manufactured in enamelled steel.
With halogen bulb.

| Articolo - Item | €/pc. | Vetro-Glass Ø mm. | Base Ø mm. | Light | Colore luce Light colour | kg. |
|-----------------|-------|-------------------|------------|---------|--------------------------|-------|
| L 44 00 550 | | 95 | 140 | 12V 10W | Bianco-White | 0,210 |



12V

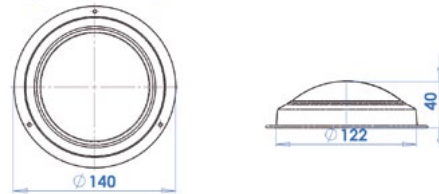

Faretto alogeno

Fabbricata in ottone lucidato.
Vetro satinato.

Halogen spotlight

Manufactured in polished brass.
Glazed glass.

| Articolo - Item | €/pc. | Ø mm. | Light | Colore luce Light colour | kg. |
|-----------------|-------|-------|---------|--------------------------|-------|
| L 44 00 172 | | 90 | 12V 10W | Bianco-White | 0,260 |



12V

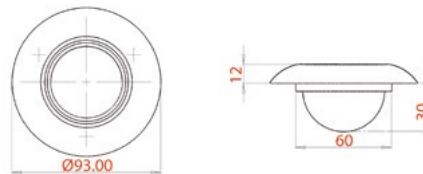

Plafoniera tonda

Provista di lampadina e tubo 1W.

Ceiling light

With bulb and tube 1W.

| Articolo - Item | €/pc. | Vetro-Glass Ø mm. | Base Ø mm. | Light | Colore luce Light colour | kg. |
|-----------------|-------|-------------------|------------|--------|--------------------------|-------|
| L 44 74 951 | | 120 | 152 | 12V 3W | Bianco-White | 0,190 |



12V

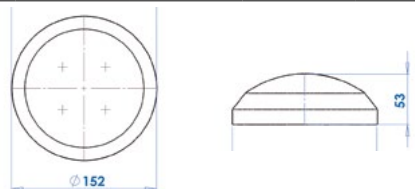



LUCI DI CORTESIA ALOGENE | HALOGEN COURTESY LIGHTS

Luce di cortesia e segnapasso

Fabbricata in materia plastica con anello di copertura inox.

Courtesy light

Manufactured in plastic material with stainless steel cover.

| Articolo - Item | €/pc. | Ø mm. |  | Colore luce Light colour |  kg. |
|-----------------|-------|-------|---|-----------------------------|---|
| L 44 00 139 | | 80 | 12V 10W | Bianco-White | 0,070 |

 12V

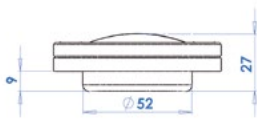
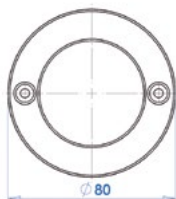

Luce di cortesia ovale

Fabbricata in materia plastica con cornice in alluminio anodizzato.

Oval courtesy light

Manufactured in plastic with frame in anodised aluminium.

| Articolo - Item | €/pc. | Colore lente Lens colour |  |  kg. |
|-----------------|-------|---|---|---|
| L 44 82 169 | |  | 12V 10W | 0,070 |

 12V

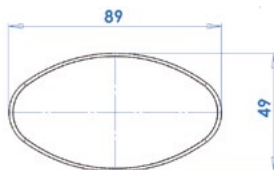
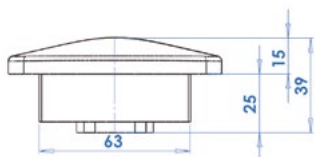

Luce di cortesia

Corpo fabbricato in acciaio inox e vetro esterno in plexiglass.

Courtesy light

Body in stainless steel and outer glass in plexiglass.

| Articolo - Item | €/pc. | Mod. |  | Colore luce Light colour |  kg. |
|-----------------|-------|-------------|---|-----------------------------|---|
| L 44 50 000 | | Tondo-Round | 12V | Bianco-White | 0,150 |

 12V

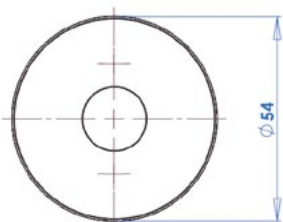

LUCI DA ESTERNO ALOGENE | OUTDOOR HALOGEN LIGHTS

Plafoniera da incasso

Lente in vetro satinato. Indicata anche per pozzetti o sala motore. Finitura in ottone cromato.

Recessed mounting light

Satin-finish glass. Suitable for cockpits or engine rooms. Chrome-plated brass finishing.

| Articolo - Item | €/pc. | Volts | Watt | Lumen | Tipo lampadina Bulb type | Colore luce Light colour |  kg. |
|-----------------|-------|-------|------|-------|-----------------------------|-----------------------------|---|
| L 44 15 148 | | 12 | 20 | - | G4 | Bianco-White | 0,210 |

 12V

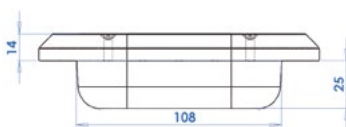
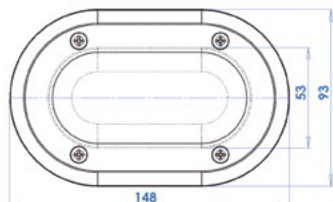

Luce «Star Lux»

Fabbricata in plastica con vetro in policarbonato. Per utilizzo da interno o da esterno.

«Star Lux» light

Manufactured in plastic material with Polycarbonate glass. Suitable for indoor and outdoor application.

| Articolo - Item | €/pc. | Mod. | ↑ mm. | Colore luce Light colour |  kg. |
|-----------------|-------|---------------|------------|-----------------------------|---|
| L 44 10 285 | | 1x10W Halogen | 250x87x56H | Bianco-White | 0,280 |

 12V

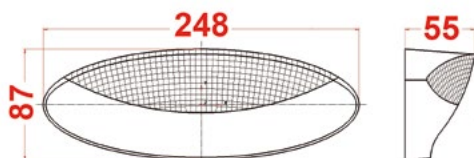

VISIT OUR B2B AREA

CREATE A CUSTOMER ACCOUNT
CHECK AVAILABILITY & QUANTITY OF ITEMS
CHECK YOUR COMMERCIAL CONDITION
PLACE YOUR ORDER
TRACK YOUR ORDER STATUS
TRACK YOUR PAYMENT PROCESS



WWW.TREM.NET



LAMPADINE | BULBS

| Foto Picture | Articolo - Item | €/pc. | €/box | Volt | Watt | Attacco Fitting | mm. | Montata di serie Standard fitted | Optional per fanale Optional for light | Box | kg. |
|--------------|-----------------|-------|-------|------|------|-----------------|---------|---------------------------------------|--|-----|-----|
| | L 08 08 012 | | | 12 | 7 | Siluro | 11x39,5 | Mini Star | - | | |
| | L 08 10 012 | | | 12 | 10 | Siluro | 11x38,5 | Orsa Minore | - | | |
| | L 08 08 024 | | | 24 | 10 | Siluro | 11x38 | - | Orsa Minore Mini Star | | |
| | L 08 15 012 | | | 12 | 15 | Siluro | 15x44 | Stella Polare 12V. 112,5° - 125° | - | | |
| | L 08 10 041 | | | 12 | 10 | Siluro | 11x44 | Stella Polare 12V. 135° Croce del Sud | - | | |
| | L 08 15 024 | | | 24 | 15 | Siluro | 15x44 | Stella Polare 24V. 112,5° - 125° | - | | |
| | L 08 10 024 | | | 24 | 10 | Siluro | 11x44 | Stella Polare 24V. 135° Croce del Sud | Croce del Sud | | |

| Foto Picture | Articolo - Item | €/pc. | €/box | Volt | Watt | Attacco Fitting | mm. | Montata di serie Standard fitted | Optional per fanale Optional for light | Box | kg. |
|--------------------------------------|-----------------|-------|-------|------|------|-----------------|-----|----------------------------------|--|-----|-----|
| LAMPADINE BA15D - BA15D BULBS | | | | | | | | | | | |
| | L 08 12 010 | | | 12 | 10 | BA15D | 15 | Pole 360° | - | | |
| | L 08 24 010 | | | 24 | 10 | BA15D | 15 | - | Pole 360° | | |

Lampadina ricambio per fanali a pila attacco E10 12V

Spare bulb for battery powered navigation lights fitting E10 12V

| Articolo - Item | €/pc. | €/box | Tipo-Type | Adatto per Suitable for | kg. |
|-----------------|-------|-------|-----------|-------------------------|-----|
| L 07 00 015 | | | 1,5V 0,3A | L 39 00 065 | |



Lampadina ricambio per boette attacco E10 12V

Spare bulb for lifebuoy lights fitting E10 12V

| Articolo - Item | €/pc. | €/box | Tipo-Type | Adatto per Suitable for | kg. |
|-----------------|-------|-------|-----------|-------------------------|-----|
| L 07 16 045 | | | 4,5V 1,6W | L 19 90 450 S | |



AREA DIDATTICA | EDUCATIONAL AREA

TEMPERATURA DI COLORE - COLOUR TEMPERATURE

La **Temperatura Colore** indica la tonalità della luce e si misura in **KELVIN (K)**. Ogni sorgente luminosa ha una propria temperatura colore caratteristica, che va dal caldo (come una candela, 1000K) al freddo (lampadina allo Xeno 6200K). Le luci fredde, oltre i 5300K, tendono all'azzurro/blu. Le lampade a incandescenza tradizionali sono a luce calda, circa 2900K, ma per illuminare aree di lavoro normalmente si utilizzano luci più fredde, tra i 3500K e 6000K. La luce calda (2900K) si usa per ambienti familiari, mentre luci fredde (tra 3500K e 6000K) sono più indicate per ambienti di lavoro.

The **Color Temperature** indicates the shade of light and is measured in **KELVIN (K)**. Each light source has its own characteristic color temperature, ranging from hot (like a candle, 1000K) to cold (6200K Xenon bulb). Cold lights, above 5300K, tend to light blue/blue. Traditional incandescent lamps have warm light, about 2900K, but cooler lights are normally used to illuminate working spaces, between 3500K and 6000K. Warm light (2900K) is used for family environments, while cold lights (between 3500K and 6000K) are more suitable for work environments.



LAMPADINE | BULBS

Lampadine a LED SMD

Sostituiscono tutte le lampadine alogene da 10 watt con attacco laterale. Generano una luminosità pari alla alogena da 10 Watt con una durata di 10.000 ore.

SMD LED

Suitable to replace the halogen bulbs 10 watt with side fitting. They can generate the same lighting of halogen bulbs 10 watt with a working time of 10.000 hours.

| Articolo - Item | €/pc. | Attacco Fitting | Ø chip mm. | Volts | Watt | Watt equivalenti Equivalent watt | LED | Luce-Light | Lumen | kg. |
|-----------------|-------|-----------------|------------|-------|------|----------------------------------|------|-------------|-------|-------|
| L 44 06 023 | | G4 laterale | 23 | 9-32 | 1,8 | 7 | A-6 | Fredda-Cold | 70 | 0,010 |
| L 44 09 028 | | G4 laterale | 28 | 9-32 | 1,8 | 15 | B-9 | Fredda-Cold | 130 | 0,010 |
| L 44 12 030 | | G4 laterale | 30 | 9-32 | 1,5 | 20 | C-12 | Fredda-Cold | 130 | 0,010 |
| L 43 06 023 | | G4 laterale | 23 | 9-32 | 1,8 | 7 | A-6 | Calda-Warm | 70 | 0,010 |
| L 43 09 028 | | G4 laterale | 28 | 9-32 | 1,8 | 15 | B-9 | Calda-Warm | 130 | 0,010 |
| L 43 12 030 | | G4 laterale | 30 | 9-32 | 1,5 | 20 | C-12 | Calda-Warm | 130 | 0,010 |

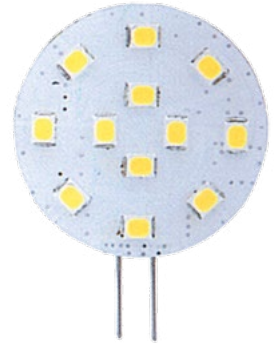

Lampadina e circuito a LED per boette TR.EM.

LED bulb and circuit for TR.EM. lifebuoy lights

| Articolo - Item | €/pc. | Mod. | Attacco Fitting | Volts | Watt | LED | Lumen | kg. |
|-----------------|-------|---------------------|-----------------|-------|------|-----|-------|-------|
| L 44 01 006 | | Per boetta L1900240 | E10 | 6 | 1,0 | 1 | 60 | 0,010 |



Lampadina e circuito a LED per boette TR.EM.

LED bulb and circuit for TR.EM. lifebuoy lights

| Articolo - Item | €/pc. | Lunghezza Length mm. | LED Power | Lente Lens | Volts | kg. |
|-----------------|-------|----------------------|-----------|------------|-------|-------|
| L 44 00 010 | | 42xØ12 | 6x0,5W | SI-YES | 12 | 0,010 |



Lampadina a LED a baionetta BA15D

Bayonet LED bulb BA15D

| Articolo - Item | €/pc. | H mm. | Led colour | Contatto Contact | Volts | LED | Adatti per Suitable for | kg. |
|-----------------|-------|-------|------------|------------------|-------|----------|-------------------------|-------|
| L 44 74 063 | | 31 | | Parallel | 12 | 9 x 0,7W | Pole 360 | 0,010 |



BA15D

Dual Contact Bayonet DC Marine

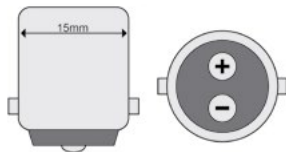

Lampadina a LED a baionetta 360° BA15D

Bayonet LED bulb 360° BA15D

| Articolo - Item | €/pc. | H mm. | Led colour | Ø mm. | Volts | LED | Adatti per Suitable for | kg. |
|-----------------|-------|-------|------------|-------|-------|-----------|-------------------------|-------|
| L 44 91 010 | | 42 | | 20 | 12 | 10 x 0,2W | Pole 360 | 0,020 |



POLI IN LINEA
IN-LINE POLES

Lampadine a LED SMD zoccolo BA15D per faretto

LED bulbs SMD base BA15D for spotlights

| Articolo - Item | €/pc. | Volts | Watt | Watt equivalenti Equivalent watt | LED | Luce-Light | Lumen | ↕ mm. | kg. |
|-----------------|-------|-------|------|-------------------------------------|-----|-------------------|-------|---------|-----|
| L 44 12 156 | | 12/24 | 2,0 | 12 | 13 | Calda-Warm 3000K | 156 | Ø16x41L | |
| L 44 00 156 | | 12/24 | 2,0 | 12 | 13 | Fredda-Cold 6000k | 156 | Ø16x41L | |



BA15D
Dual Contact Bayonet
DC Marine

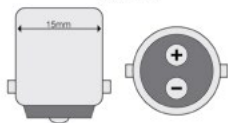

Lampadine a LED SMD zoccolo BA15D per faretto con copertura in resina

LED bulbs SMD base BA15D for spotlights with resin covering

| Articolo - Item | €/pc. | Volts | Watt | Watt equivalenti Equivalent watt | LED | Luce-Light | Lumen | ↕ mm. | kg. |
|-----------------|-------|-------|------|-------------------------------------|-----|-------------------|-------|---------|-----|
| L 44 00 200 | | 12/24 | 2,5 | 20 | 48 | Calda-Warm 3000K | 200 | Ø13x40L | |
| L 44 20 200 | | 12/24 | 2,5 | 20 | 48 | Fredda-Cold 6000k | 200 | Ø13x40L | |



BA15D
Dual Contact Bayonet
DC Marine

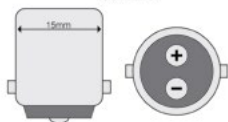

Lampadine a LED BAY15D perni disassati per fanali di via con copertura in resina

LED bulbs BAY15D with pins out of axis for navigation lights with resin covering

| Articolo - Item | €/pc. | Volts | Watt | Watt equivalenti Equivalent watt | LED | Luce-Light | Lumen | ↕ mm. | kg. |
|-----------------|-------|-------|------|-------------------------------------|-----|-------------------|-------|---------|-----|
| L 44 20 215 | | 12/24 | 2,5 | 20 | 48 | Calda-Warm 3000K | 200 | Ø13x40L | |
| L 44 00 215 | | 12/24 | 2,5 | 20 | 48 | Fredda-Cold 6000k | 200 | Ø13x40L | |



BAY15D
Dual Contact Bayonet
DC Marine

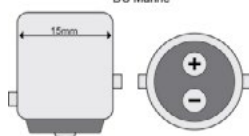

Lampadine a siluro a LED

Provviste di LED con irraggiamento totale sui 360°.

LED festoon bulbs

With 360° lighting LED.

| Articolo - Item | €/paio-pair | Lunghezza Length mm. | Volts | Watt | Chip | LED | Adatta per fanali Suitable for lights | Luce-Light | kg. |
|-----------------|-------------|-------------------------|-------|------|------|-----|--|--------------------|-------|
| L 44 10 031 B | | 31 | 12 | 0,8 | 12 | 4 | - | Fredda- Cold 6000k | 0,010 |
| L 44 10 039 B | | 39 | 12 | 1,7 | 24 | 8 | Mini Star-Orsa Minore | Fredda- Cold 6000k | 0,010 |
| L 44 10 044 B | | 44 | 12 | 2,4 | 36 | 12 | Croce del Sud-Stella Polare | Fredda- Cold 6000k | 0,010 |
| L 43 10 039 B | | 39 | 12 | 1,7 | 24 | 8 | Mini Star-Orsa Minore | Calda-Warm 3000K | 0,010 |
| L 43 10 044 B | | 44 | 12 | 2,4 | 36 | 12 | Croce del Sud-Stella Polare | Calda-Warm 3000K | 0,010 |



L4410031B



L4310039B
L4410039B



L4310044B
L4410044B

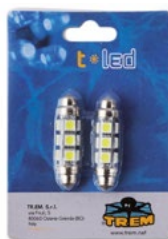

Lampadine a siluro a LED

Provviste di LED con irraggiamento totale sui 360°.

LED festoon bulbs

With 360° lighting LED.

| Articolo - Item | €/pc. | H mm. | Volts | Watt | LED | Luce-Light | kg. |
|-----------------|-------|-------|-------|------|-------------------|------------------|-----|
| L 44 12 039 | | 39 | 12 | 2,0 | MONOFILAMENT 360° | Calda-Warm 3000K | |
| L 44 12 044 | | 44 | 12 | 2,0 | MONOFILAMENT 360° | Calda-Warm 3000K | |



VISIT OUR NEW WEB SITE



WWW.TREM.NET



MARINE
EMERGENCY VEHICLE
INDUSTRIAL
RV



Battery Management
Circuit Protection & Switches
Connectors & Insulators
Custom Panels
Meters
Power Conversion & Connection
Power Distribution



Coprиморsetti testa quadra

Realizzati in robustissimo Pvc morbido.

Square cable cap insulators

Insulates battery terminals which have in-line dual posts.

| Articolo - Item | €/Paia-Pairs | Mod. | Colore Colour | Paia-Pairs | kg. |
|-----------------|--------------|------|---------------|------------|-------|
| K 00 04 018 | | 4018 | Red-Black | 5 | 0,090 |



Cappucci in Pvc isolanti

Realizzati in Pvc morbido.

Utili per isolare terminali di potenza su batterie, alternatori, motorini di avviamento, portafusibili, verricelli e altri servizi ad alta potenza.

Stud cable cap insulators

Made of strong soft Pvc.

Insulates single stud on alternators, starters, windlasses and high amperage termination points.

| Articolo - Item | €/box | Mod. | Sezione cavo Cable section mm2 | Colore Colour | kg. |
|-----------------|-------|-------|--------------------------------|---------------|-------|
| K 00 04 011 | | 4011B | 10 - 25 | Black | 0,500 |
| K 00 04 012 | | 4012B | 35 - 70 | Red | 0,750 |
| K 00 04 013 | | 4013B | 35 - 70 | Black | 0,750 |
| K 00 04 015 | | 4015B | 95 - 120 | Black | 0,750 |



NODI PER CAVI | CABLE CONNECTORS



Nodi di potenza passanti

Questi connettori sono indicati per il collegamento dei cavi attraverso scafi, paratie, coperte. Rendono la connessione stagna ed eliminano eventuali spellature del cavo. Contatti in rame argentato. Supporto in materiale termoplastico rinforzato.

Terminal feed through connectors

Eliminates chafe and provides strain relief when passing high current through hulls, decks and bulkheads. Protects large cables that are subject to chafing when passed through holes. The large terminals have a mounting face that can be gasketed or bedded to provide a water tight installation.

| Articolo - Item | €/pc. | Mod. | Sez bullone Bolt section | Amp. continuo Continuous rating | Tensione Voltage max DC | Foro passante Hole Ø mm. | Colore Colour | kg. |
|-----------------|-------|------|--------------------------|---------------------------------|-------------------------|--------------------------|---------------|-------|
| K 02 02 202 | | 2202 | M8 | 250A | 48V | 21,84 | Red | 0,140 |
| K 02 02 201 | | 2201 | M8 | 250A | 48V | 21,84 | Black | 0,140 |
| K 02 02 204 | | 2204 | M10 | 250A | 48V | 21,84 | Red | 0,140 |
| K 02 02 203 | | 2203 | M10 | 250A | 48V | 21,84 | Black | 0,140 |

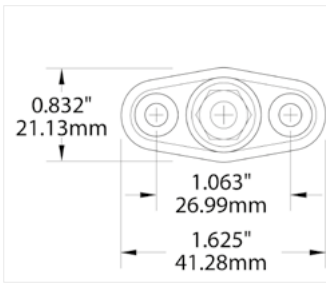

Nodi per cavi alto amperaggio

Adatti per alto amperaggio, determinati non dal nodo, ma dal diametro del cavo. Base in materiale termoplastico rinforzato. Barra in rame argentato. Perni in acciaio inox. Cappuccio rosso di protezione. Voltage max 48V

Powerpost cable connectors

Insulated single stainless steelstud terminates multiple large conductors. Connects high amperage cables securely. Includes insulator. Stainless steel pin. Red protection cap. Voltage max 48V

| Articolo - Item | €/pc. | Mod. | Sezione bullone Bolt section | Colore cappuccio Insulator colour | kg. |
|-----------------|-------|------|------------------------------|-----------------------------------|-------|
| K 02 02 011 | | 2011 | M6 | Red | 0,020 |
| K 02 02 002 | | 2002 | M8 | Red | 0,110 |
| K 02 02 003 | | 2003 | M10 | Red | 0,120 |



INTERRUTTORI MONTAGGIO SU BATTERIA | BATTERY MOUNT SWITCHES

Interruttori montaggio su batteria

SAE J1171. Standard IP54 resistente agli spruzzi d'acqua da tutte le direzioni.

Terminale batteria montaggio su morsetto

- Connettori in rame stagnato
- Fori di montaggio ø 3/8" per entrambi i terminali
- Terminale batteria montaggio su perno
- Connettori in ottone stagnato
- Fori di montaggio standard per entrambi i terminali

Battery mount switches

Meets SAE J1171 external ignition protection requirements IP54-protected against water splashed in all directions.

Battery Terminal Stud Mount

- Tin-plated copper bus
- 3/8" mounting hole for either terminals
- Battery Post Mount
- Tin-plated brass bus
- They fit standard tapered post for either terminals

| Articolo - Item | €/pc. | Mod. | Cranking rating: 30sec. | Intermittent rating: 5min. | Amp. continuo Continuous rating | Tensione Voltage max | Descrizione-Description |
|-----------------|-------|-------|-------------------------|----------------------------|---------------------------------|----------------------|---|
| K 00 05 990 | | 5990B | 450A | 225A | 150A | 32V DC | Terminale batteria montaggio su morsetto Battery terminal stud mount |
| K 00 05 991 | | 5991B | 450A | 225A | 150A | 32V DC | Terminale batteria montaggio su perno Battery post mount |

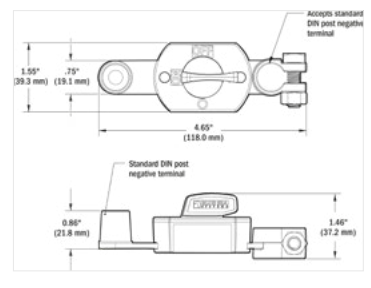
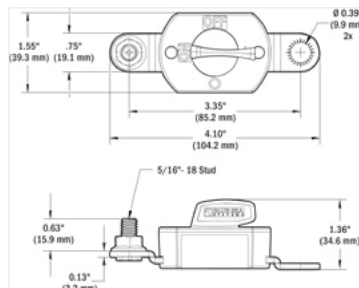
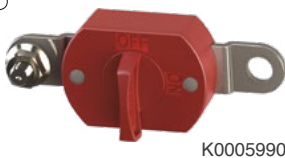

Accessorio per collegare in parallelo gli staccabatteria

Paralleling link bus to link multiple battery switches

| Articolo - Item | €/pc. | Mod. | kg. |
|-----------------|-------|-------|-------|
| K 06 09 159 | | 9159B | 0,140 |



TELERUTTORI E SOLENOIDI | SOLENOID SWITCHES & REMOTE CONTROL SWITCHES

Solenoide bistabile «Blue Sea» Serie ML

ML-Series solenoid switches

Stagno, completamente protetto dalla corrosione (IP 67).
 Funzionamento bistabile: consumo di corrente solo in fase di eccitazione e diseccitazione, nessun assorbimento in fase stabile.
 Contatti in rame argentato. Risponde alle norme: SAE J1171 - ISO 8846. Anti-deflagrante.
 Indicato per l'installazione su motori a benzina.

500 Amp magnetic latching (bi-stable) solenoid provides high-amp switching under load where manual control is not required.
 LED output to remotely indicate switch state. 3-8"-16 tin-plated copper studs for maximum conductivity and corrosion resistance.
 Label recesses for circuit identification. Silver alloy contacts provide high reliability for switching live loads.

| Articolo - Item | €/pc. | Mod. | Tensione Voltage V | Potenza cont Cont rating | Potenza interm. 5 min. Intermittent rating | Potenza 10 sec. 10 sec. rating | Comando manuale Hand control | Comando bobina Coil control | Terminali Terminal size | Bobina Coil | Controllo man Man control | kg. |
|-----------------|-------|-------|--------------------|--------------------------|--|--------------------------------|------------------------------|-----------------------------|-------------------------|-------------|---------------------------|-------|
| K 09 07 701 | | 7701B | 12 | 300A | 500A | 2500A | No | 2 fili-wires | M10 | Isolata | No | 0,920 |

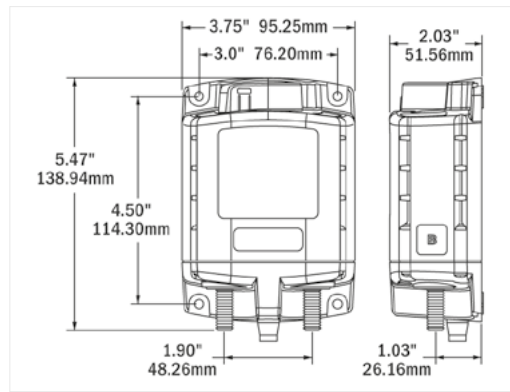

Interruttori dedicati IP 67

Remote control Contura switch IP67

Studiati per facilitare e ottimizzare l'utilizzo dei solenoidi bistabili.
 Solo interruttore a pulsante con blocco meccanico.
 Tre interruttori a pulsante montati su pannello 360 «Blue Sea».

Specially designed for ML-series solenoid switches.
 Switch with mechanical lock.
 Three switches fitted on «Blue Sea» 360 panel.

| Articolo - Item | €/pc. | Mod. | Funzione Function | N. interruttori N. of switches | pannello Panel mm. | Potenza max Max power 12V | Potenza max Max power 24V | Interblocco sicurezza Safety lock | Retro illuminaz tasto Rear lighting key | kg. |
|-----------------|-------|------|-------------------|--------------------------------|--------------------|---------------------------|---------------------------|-----------------------------------|---|-------|
| K 09 02 145 | | 2145 | ON-OFF-ON | 1 | No | 20A | 15A | Si - Yes | Led | 0,040 |
| K 09 01 148 | | 1148 | ON-OFF-ON | 3 | 123,8x120,6x50,8 | 20A | 15A | Si - Yes | Led | 0,380 |



Solenoide «Blue Sea» 12-24V.

«Blue Sea» solenoid switch 12-24V.

Basso assorbimento della bobina (Max 3.8A).
 Stagno, completamente protetto dalla corrosione.
 Anti-deflagrante. Indicato per l'installazione su motori a benzina.

Hermetically sealed contacts. Activated by an ON-OFF switch mounted remotely.
 Integrated coil control minimizes heating and amperage draw.
 Mount in a dry location.

| Articolo - Item | €/pc. | Mod. | Tensione Voltage CC | Potenza cont Cont rating | Potenza 30 sec. 30 sec. rating | mm. | Comando bobina Coil control | Terminali Terminal size | Bobina Coil | Materiale involucro Case material | kg. |
|-----------------|-------|-------|---------------------|--------------------------|--------------------------------|-------------------|-----------------------------|-------------------------|-------------|-----------------------------------|-------|
| K 09 09 012 | | 9012B | 12-24V | 300A | 1000A | 80,52x66,80x72,64 | 2 fili-wires | M8 | Isolata | Plastica - Plastic | 0,450 |

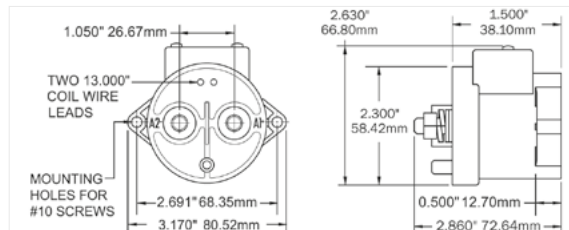

Staccabatteria «Mini» 300A . a chiave e pomello

Montaggio esterno o ad incasso. Realizzato in policarbonato rinforzato. Leva di comando sfilabile. Terminali di generose dimensioni in rame argentato stampati a caldo. Contatti in rame argentato.

Battery switch «Mini» 300A. with key and knob

Made of reinforced polycarbonate. Case design allows surface, rear, or front panel mounting options. Removable key. Tin-plated copper studs for maximum conductivity and corrosion resistance.

| Articolo - Item | €/pc. | Mod. | Potenza continua Continuous rating | Potenza interm. Intermittent rating 5 min. | Potenza 10 sec. 10 sec. rating | Tensione Voltage | Poli interr N. Poles N. | Sezione perni Pins | Foro incasso Hole mm. | ↑ mm. | kg. |
|-----------------|-------|-------|---------------------------------------|---|-----------------------------------|---------------------|----------------------------|-----------------------|--------------------------|-------------------|-------|
| K 06 06 005 | | 6005B | 300A | 500A | 1500A | 48V | 1 | M10 | 60,33 | 71,76x71,76x77,94 | 0,280 |
| K 06 06 006 | | 6006B | 300A | 500A | 1500A | 48V | 1 | M10 | 60,33 | 71,76x71,76x77,94 | 0,290 |
| K 06 06 004 | | 6004B | 300A | 500A | 1500A | 48V | 1 | M10 | 60,33 | 71,76x71,76x77,94 | 0,290 |



K0606005



K0606006



K0606004

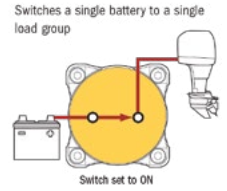

Staccabatteria «Mini» bipolare 300A .

Interruttore simultaneo di polo positivo e negativo. Montaggio esterno o ad incasso. Realizzato in policarbonato rinforzato. Leva di comando sfilabile. Terminali di generose dimensioni in rame argentato stampati a caldo. Contatti in rame argentato.

Dual circuit battery switch «Mini» 300A.

Simultaneously switches the positive and negative conductors. Made of reinforced polycarbonate. Case design allows surface, rear, or front panel mounting options. Removable key. Tin-plated copper studs for maximum conductivity and corrosion resistance.

| Articolo - Item | €/pc. | Mod. | Potenza continua Continuous rating | Potenza interm. Intermittent rating 5 min. | Potenza 10 sec. 10 sec. rating | Tensione Voltage | Poli interr N. Poles N. | Sezione perni Pins | Foro incasso Hole mm. | ↑ mm. | kg. |
|-----------------|-------|-------|---------------------------------------|---|-----------------------------------|---------------------|----------------------------|-----------------------|--------------------------|-----------------------|-------|
| K 06 06 010 | | 6010B | 300A | 450A | 1000A | 32V | 2 | M10 | 60,33 | 71,76x71,76 x77,94 | 0,360 |

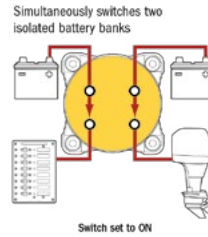

Deviatore «Mini» 0-1-2 BOTH

Montaggio esterno o ad incasso. Realizzato in policarbonato rinforzato. Contatti in rame argentato.

Single circuit ON-OFF

Made of reinforced polycarbonate. Surface, rear, or front panel mounting options. Switches a single battery to a single load group.

| Articolo - Item | €/pc. | Mod. | Potenza continua Continuous rating | Potenza interm. Intermittent rating 5 min. | Potenza 10 sec. 10 sec. rating | Tensione Voltage | Poli interr N. Poles N. | Sezione perni Pins | Foro incasso Hole mm. | ↑ mm. | kg. |
|-----------------|-------|-------|---------------------------------------|---|-----------------------------------|---------------------|----------------------------|-----------------------|--------------------------|-----------------------|-------|
| K 06 06 007 | | 6007B | 300A | 500A | 1500A | 32V | 1 | M10 | 60,33 | 71,76x71,76 x77,94 | 0,350 |

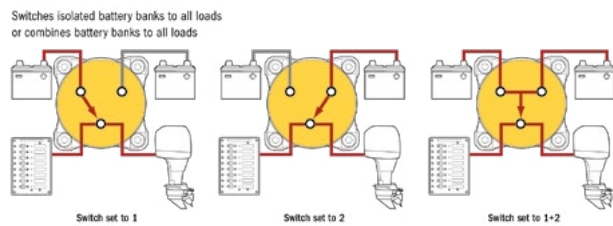

Speciale «Mini» staccabatteria - parallelatore 300A.

Doppi contatti per un doppio circuito (4 perni in rame argentato). Apre e chiude simultaneamente i circuiti di due banche batterie. Mantiene l'isolamento tra due banche di batterie. Nella posizione BOTH commuta in parallelo i due banche batterie. Montaggio esterno o ad incasso. Contatti in rame argentato.

Dual circuit Plus 300A.

Simultaneously switches two isolated battery banks or combines battery banks to all loads. Can not be used to switch positive and negative conductors because of the combine feature. Surface, rear, or front panel mounting options. Terminal studs made of tin-plated copper.

| Articolo - Item | €/pc. | Mod. | Potenza continua Continuous rating | Potenza interm. Intermittent rating 5 min. | Potenza 10 sec. 10 sec. rating | Tensione Voltage | Poli interr N. Poles N. | Sezione perni Pins | Foro incasso Hole mm. | ↑ mm. | kg. |
|-----------------|-------|-------|---------------------------------------|---|-----------------------------------|---------------------|----------------------------|-----------------------|--------------------------|-----------------------|-------|
| K 06 06 011 | | 6011B | 300A | 450A | 1000A | 32V | 1 | M10 | 60,33 | 71,76x71,76 x77,94 | 0,360 |

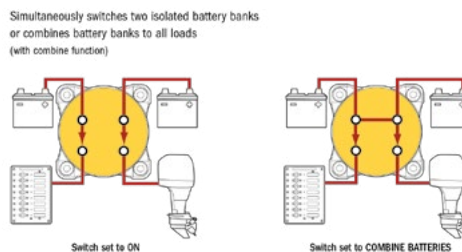

Deviatore «Maxi» Heavy Duty 0-1-2 BOTH

Perni di collegamento in rame argentato da 12 mm.
Montaggio esterno o ad incasso.
Contatti in rame argentato.

Selector 4 position «Maxi» Heavy Duty

Switches isolated battery banks to all loads or combines battery banks to all load.
Surface, rear, or front panel mounting options.
Terminal studs made of tin-plated copper.

| Articolo - Item | €/pc. | Mod. | Potenza continua Continuous rating | Potenza intermittente Intermittent rating 5 min. | Potenza 10 sec. 10 sec. rating | Tensione Voltage | Poli interr N. Poles N. | Sezione perni Pins | Foro incasso Hole mm. | ↑ mm. x78,67 | kg. |
|-----------------|-------|-------|---------------------------------------|---|-----------------------------------|---------------------|----------------------------|-----------------------|--------------------------|-----------------------|-------|
| K 06 03 002 | | 3002B | 500A | 700A | 2750A | 32V | 1 | M12 | 92,08 | 97,79x97,79 x78,67 | 0,570 |

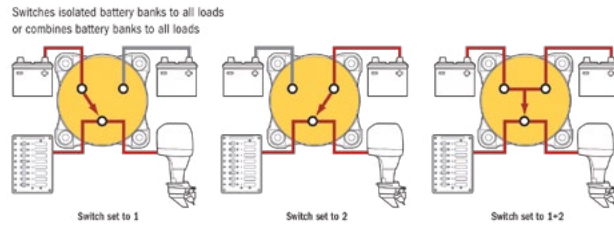

Staccabatteria Maxi Super Heavy Duty 600A .

Elevatissima potenza e ingombri ridotto. Montaggio esterno o ad incasso. Realizzato in policarbonato rinforzato. Terminali di generose dimensioni in rame argentato stampati a caldo. Contatti in rame argentato.

Single circuit ON-OFF «Maxi» 600A.

Made of reinforced polycarbonate.
Switches a single battery to a single load group.
Surface, rear, or front panel mounting options.
Terminal studs made of tin-plated copper.

| Articolo - Item | €/pc. | Mod. | Potenza continua Continuous rating | Potenza intermittente Intermittent rating 5 min. | Potenza 10 sec. 10 sec. rating | Tensione Voltage | Poli interr N. Poles N. | Sezione perni Pins | Foro incasso Hole mm. | ↑ mm. x78,67 | kg. |
|-----------------|-------|-------|---------------------------------------|---|-----------------------------------|---------------------|----------------------------|-----------------------|--------------------------|-----------------------|-------|
| K 06 03 000 | | 3000B | 600A | 900A | 2750A | 32V | 1 | M12 | 92,08 | 97,79x97,79 x78,67 | 0,590 |

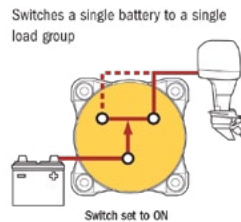

Staccabatteria Maxi 350A .

Montaggio esterno o ad incasso. Realizzato in policarbonato rinforzato. Terminali di generose dimensioni in rame argentato stampati a caldo. Contatti in rame argentato.

Battery switch «Maxi» 350A.

Made of reinforced polycarbonate. Surface, rear, or front panel mounting options. Switches a single battery to a single load group. Terminal studs made of tin-plated copper.

| Articolo - Item | €/pc. | Mod. | Potenza continua Continuous rating | Potenza intermittente Intermittent rating 5 min. | Potenza 10 sec. 10 sec. rating | Tensione Voltage | Poli interr N. Poles N. | Sezione perni Pins | Foro incasso Hole mm. | ↑ mm. x78,67 | kg. |
|-----------------|-------|--------|---------------------------------------|---|-----------------------------------|---------------------|----------------------------|-----------------------|--------------------------|-----------------------|-------|
| K 06 09 003 | | 9003eB | 350A | 600A | 2000A | 48V | 1 | M10 | 92,08 | 97,79x97,79 x78,67 | 0,590 |

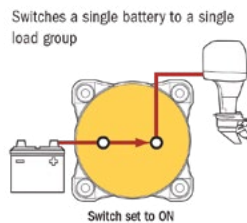

Deviatore Maxi 0 – 1 – 2

Deviatore a tre posizioni senza la funzione both.
Perni in rame argentato M10.
Contatti in rame argentato.

Selector 3 position

Switches isolated battery banks to all loads.
Pins made of M10 tin-plated copper.
Terminal studs made of tin-plated copper.

| Articolo - Item | €/pc. | Mod. | Potenza continua Continuous rating | Potenza interm.ittente Intermittent rating 5 min. | Potenza 10 sec. 10 sec. rating | Tensione Voltage | Poli interr N. Poles N. | Sezione perni Pins | Foro incasso Hole mm. | ↑ mm. x78,67 | kg. |
|-----------------|-------|---------|---------------------------------------|--|-----------------------------------|---------------------|----------------------------|-----------------------|--------------------------|-----------------------|-------|
| K 06 11 001 | | 11001 B | 350A | 600A | 2000A | 32V | 1 | M10 | 92,08 | 97,79x97,79 x78,67 | 0,590 |

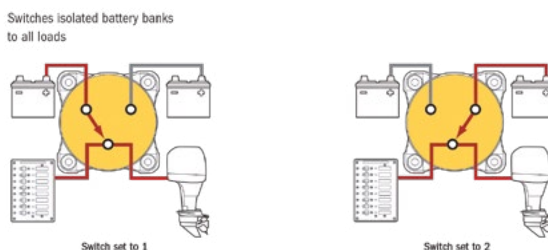

Deviatore Maxi Heavy Duty 0 - 1 - 2

Deviatore altissima potenza a tre posizioni senza la funzione both.
Perni in rame argentato M12.
Contatti in rame argentato.

Selector 3 position «Maxi» Heavy Duty

Switches isolated battery banks to all loads.
Surface, rear, or front panel mounting options.
Terminal studs made of tin-plated copper.

| Articolo - Item | €/pc. | Mod. | Potenza continua Continuous rating | Potenza interm. Intermittent rating 5 min. | Potenza 10 sec. 10 sec. rating | Tensione Voltage | Poli interr N. Poles N. | Sezione perni Pins | Foro incasso Hole mm. | ↑ ↓ mm. | kg. |
|-----------------|-------|--------|---------------------------------------|---|-----------------------------------|---------------------|----------------------------|-----------------------|--------------------------|-----------------------|-------|
| K 06 11 003 | | 11003B | 500A | 700A | 2750A | 32V | 1 | M12 | 92,08 | 97,79x97,79 x78,67 | 0,590 |



Switches isolated battery banks to all loads

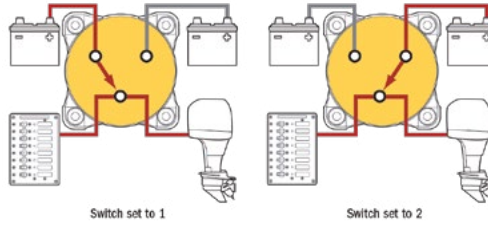

Deviatore Maxi 0 - 1 - 2 Both

Realizzato in policarbonato rinforzato.
Montaggio esterno o ad incasso. Contatti in rame argentato.

Selector 4 position

Made of reinforced polycarbonate. Surface, rear, or front panel mounting options.
Terminal studs made of tin-plated copper.

| Articolo - Item | €/pc. | Mod. | Potenza continua Continuous rating | Potenza interm. Intermittent rating 5 min. | Potenza 10 sec. 10 sec. rating | Tensione Voltage | Poli interr N. Poles N. | Sezione perni Pins | Foro incasso Hole mm. | ↑ ↓ mm. | kg. |
|-----------------|-------|--------|---------------------------------------|---|-----------------------------------|---------------------|----------------------------|-----------------------|--------------------------|-----------------------|-------|
| K 06 09 001 | | 9001eB | 350A | 600A | 2000A | 32V | 1 | M10 | 92,08 | 97,79x97,79 x78,67 | 0,590 |



Switches isolated battery banks to all loads
or combines battery banks to all loads

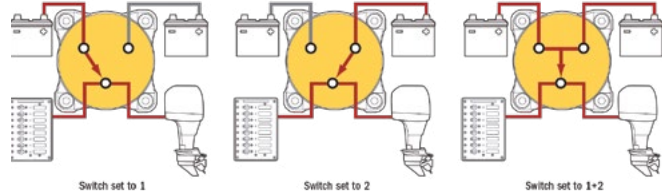

Staccabatteria Maxi Bipolare 350A .

Interruttore simultaneo di polo positivo e negativo.
Montaggio esterno o ad incasso. Realizzato in policarbonato rinforzato.
Terminali di generose dimensioni in rame argentato stampati a caldo.
Contatti in rame argentato.

Dual circuit battery switch «Maxi» 350A.

Simultaneously switches the positive and negative conductors.
Made of reinforced polycarbonate.
Case design allows surface, rear, or front panel mounting options. Removable key. Tin-plated copper studs for maximum conductivity and corrosion resistance.

| Articolo - Item | €/pc. | Mod. | Potenza continua Continuous rating | Potenza interm. Intermittent rating 5 min. | Potenza 10 sec. 10 sec. rating | Tensione Voltage | Poli interr N. Poles N. | Sezione perni Pins | Foro incasso Hole mm. | ↑ ↓ mm. | kg. |
|-----------------|-------|--------|---------------------------------------|---|-----------------------------------|---------------------|----------------------------|-----------------------|--------------------------|-----------------------|-------|
| K 06 05 510 | | 5510eB | 350A | 525A | 1500A | 32V | 2 | M10 | 92,08 | 97,79x97,79 x78,67 | 0,590 |



Simultaneously switches two isolated battery banks

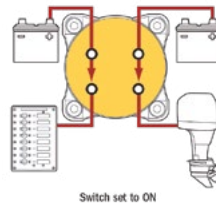

Speciale Maxi Staccabatteria - Parallelatore 350A.

Doppi contatti per un doppio circuito (4 perni in rame argentato).
Apri e chiude simultaneamente i circuiti di due banche batterie.
Mantiene l'isolamento tra due banche batterie.
Nella posizione Both commuta in parallelo i due banche batterie.
Montaggio esterno o ad incasso. Contatti in rame argentato.

Dual circuit battery switch «Maxi» 350A.

Simultaneously switches two isolated battery banks or combines battery banks to all loads.
Can not be used to switch positive and negative conductors because of the combine feature.
Surface, rear, or front panel mounting options.
Terminal studs made of tin-plated copper.

| Articolo - Item | €/pc. | Mod. | Potenza continua Continuous rating | Potenza interm. Intermittent rating 5 min. | Potenza 10 sec. 10 sec. rating | Tensione Voltage | Poli interr N. Poles N. | Sezione perni Pins | Foro incasso Hole mm. | ↑ ↓ mm. | kg. |
|-----------------|-------|--------|---------------------------------------|---|-----------------------------------|---------------------|----------------------------|-----------------------|--------------------------|-----------------------|-------|
| K 06 05 511 | | 5511eB | 350A | 525A | 1000A | 32V | 1 | M10 | 92,08 | 97,79x97,79 x78,67 | 0,590 |



Simultaneously switches two isolated battery banks or combines battery banks to all loads (with combine function)

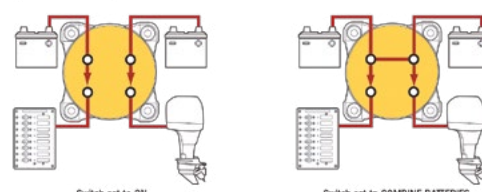

Morsettiere 20A.

Base in nylon. Ogni circuito è completamente isolato dalla superficie di montaggio.
Connessioni in ottone nickelato.

Terminal blocks 20A.

Each screw pair is one isolated circuit. Terminal block jumpers allow creation of common circuits. Closed back design completely insulates power from the mounting surface. Bus material in Nickel-plated brass.



| Articolo - Item | €/pc. | Mod. | N. vie Circuits | Sezione vite Screw section | Lunghezza Length mm. | Larghezza Width mm. | Amp. max Max rating AC/DC | Tensione max Max voltage AC/DC | kg. |
|-----------------|-------|------|-----------------|----------------------------|----------------------|---------------------|---------------------------|--------------------------------|-------|
| K 03 02 408 | | 2408 | 8 | 3 mm. | 92,96 | 22,35 | 20A | 300V | 0,050 |
| K 03 02 410 | | 2410 | 10 | 3 mm. | 112,01 | 22,35 | 20A | 300V | 0,050 |



Jumper per morsettiere da 20A.

Realizzati in ottone nickelato.

Terminal blocks jumpers 20A.

Bus material in Nickel-plated brass



| Articolo - Item | €/box | Mod. | pcs. | kg. |
|-----------------|-------|------|------|-------|
| K 03 09 218 | | 9218 | 5 | 0,010 |

Morsettiere 30A.

Base in phenolo. Ogni circuito è completamente isolato dalla superficie di montaggio.
Connessioni in ottone nickelato.

Terminal blocks 30A.

Each screw pair is one isolated circuit. Terminal block jumpers allow creation of common circuits. Closed back design completely insulates power from the mounting surface. Bus material in Nickel-plated brass.



| Articolo - Item | €/pc. | Mod. | N. vie Circuits | Sezione vite Screw section | Lunghezza Length mm. | Larghezza Width mm. | Amp. max Max rating AC/DC | Tensione max Max voltage AC/DC | kg. |
|-----------------|-------|------|-----------------|----------------------------|----------------------|---------------------|---------------------------|--------------------------------|-------|
| K 03 02 506 | | 2506 | 6 | 4 mm. | 110,24 | 33,27 | 30A | 600V | 0,100 |
| K 03 02 512 | | 2512 | 12 | 4 mm. | 195,58 | 33,27 | 30A | 600V | 0,160 |



Jumper per morsettiere da 30A.

Realizzati in ottone nickelato.

Terminal blocks jumpers 30A.

Bus material in Nickel-plated brass



| Articolo - Item | €/box | Mod. | pcs. | kg. |
|-----------------|-------|------|------|-------|
| K 03 09 217 | | 9217 | 5 | 0,020 |

Morsettiere 65A.

Base in phenolo. Ogni circuito è completamente isolato dalla superficie di montaggio.
Connessioni in ottone nickelato.

Terminal blocks 65A.

Each screw pair is one isolated circuit. Terminal block jumpers allow creation of common circuits. Closed back design completely insulates power from the mounting surface. Bus material in Nickel-plated brass.



| Articolo - Item | €/pc. | Mod. | N. vie Circuits | Sezione vite Screw section | Lunghezza Length mm. | Larghezza Width mm. | Amp. max Max rating AC/DC | Tensione max Max voltage AC/DC | kg. |
|-----------------|-------|------|-----------------|----------------------------|----------------------|---------------------|---------------------------|--------------------------------|-------|
| K 03 02 604 | | 2604 | 4 | 5 mm. | 98,55 | 45,97 | 65A | 600V | 0,120 |



Jumper per morsettiere da 65A.

Realizzati in ottone nickelato.

Terminal blocks jumpers 65A.

Bus material in Nickel-plated brass



| Articolo - Item | €/box | Mod. | pcs. | kg. |
|-----------------|-------|------|------|-------|
| K 03 09 216 | | 9216 | 5 | 0,020 |

PASSACAVI | CABLE CLAMS

Passacavi stagni

Permette l'installazione di un cavo coassiale senza rimuovere il connettore.
Viti in acciaio inox. Corpo in acetale.
Ideale per passaggio cavo GPS, VHF e Radar.

Waterproof cable clams

Provides a waterproof pass-through for antenna cables without requiring removal of the factory installed connector.
Stainless steel screws.



| Articolo - Item | €/pc. | Mod. | Cavo - Cable Ø mm. | Base Ø mm. | Connector max Ø mm. | kg. |
|-----------------|-------|------|--------------------|------------|---------------------|-------|
| K 01 01 001 | | 1001 | 4,5 - 9 | 43,18 | 17 | 0,090 |



Solenoide remoto per batterie Serie ML completo di interruttore ML-series remote battery switches with switch

Stagno, completamente protetto dalla corrosione (IP 67).
 Funzionamento bistabile: consumo di corrente solo in fase di
 eccitazione e diseccitazione, nessun assorbimento in fase stabile.
 Contatti in rame argentato.
 Risponde alle norme: SAE J1171 - ISO 8846 - UL 1500.

500 Amp magnetic latching (bi-stable) switch provides high-amp switching under load, ma-
 nually or from remote locations.
 Manual override knob provides an added level of safety, 3/8"-16 tin-plated copper studs for
 maximum conductivity and corrosion resistance. Silver alloy contacts provide high reliability
 for switching live loads.

| Articolo - Item | €/pc. | Mod. | Tensione Voltage V | Potenza cont Cont rating | Potenza interm. 5 min. Intermittent rating | Potenza Rating 10 sec. | Comando manuale Hand control | Comando bobina Coil control | Terminali Terminal size | Bobina Coil | Controllo man Handy control | Switch | ML Functions | kg. |
|-----------------|-------|-------|--------------------|--------------------------|--|------------------------|------------------------------|-----------------------------|-------------------------|-------------|-----------------------------|--------|--------------|-------|
| K 09 07 700 | | 7700B | 12 | 500A | 700A | 2500A | Si - Yes | 2 fili-wires | M10 | Isolated | Si - Yes | 2145 | Bi-Stabile | 0,930 |
| K 09 07 702 | | 7702B | 24 | 500A | 700A | 2500A | Si - Yes | 2 fili-wires | M10 | Isolated | Si - Yes | 2145 | Bi-Stabile | 0,950 |
| K 09 07 712 | | 7713B | 12 | 500A | 700A | 2500A | Si - Yes | 2 fili-wires | M10 | Isolated | Si - Yes | 2155 | Autorilascio | 0,940 |

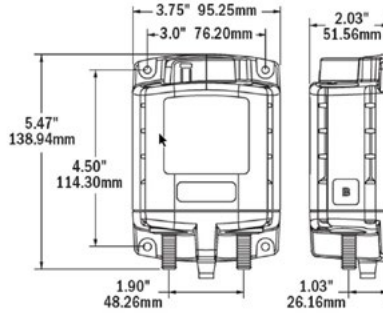

MATERIALE ELETTRICO | ELECTRICAL EQUIPMENT

RELÉ AUTOMATICI | AUTOMATIC CHARGING RELAYS

Relé automatico di carica

Funzionamento bistabile.
 Nessun assorbimento di corrente in fase stabile.
 Contatti ausiliari (normalmente aperto e normalmente chiuso).

Automatic charging relay

Automatically combines batteries during charging, isolates batteries when discharging or at rest. Senses charging on two battery banks.
 Led indicates ACR status.

| Articolo - Item | €/pc. | Mod. | Tensione Voltage V | Potenza continua Continuous rating | Potenza max picco Max peak rating 5 min. | Potenza max picco Max peak rating 1 min. | Potenza max picco Max peak rating 10 sec. | kg. |
|-----------------|-------|-------|--------------------|------------------------------------|--|--|---|-------|
| K 10 07 601 | | 7601B | 12-24 | 65A | 115A | N/A | N/A | 0,290 |

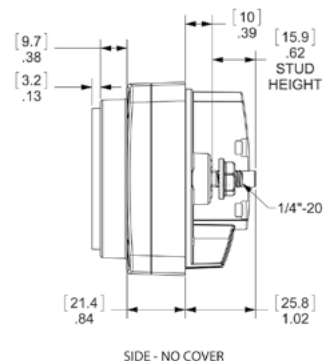
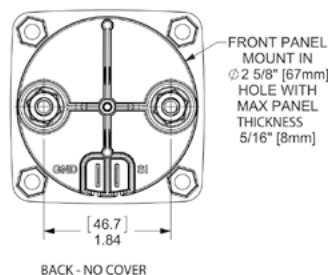
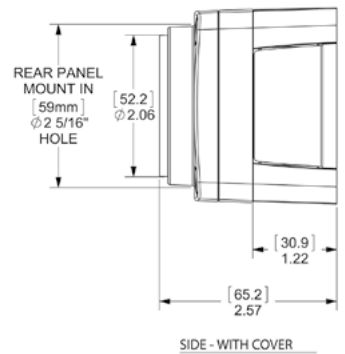
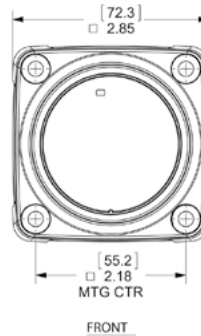

Relé automatico di carica serie SI

Involucro stagno IP 67 (immersione per 30 minuti).
 Connette automaticamente i banchi batterie durante il ciclo di carica e li disconnette durante la scarica. Funziona sia che la sorgente di carica sia un alternatore o un carica batterie. Controllo automatico per caricare più banchi batterie. Possibilità di collegare, tramite contatto ausiliario, spia di indicazione On.

SI-series automatic charging relay

Automatically combines batteries during charging, isolates batteries when discharging and when starting engines. Senses charging on two battery banks. Side and bottom knockouts for cable connections. Clip-on cover insulates terminal connections. 22 mm. stud length to accept multiple cable terminals. Integrated Led indicates ACR status.

| Articolo - Item | €/pc. | Mod. | Tensione Voltage | Chiusura contatto Contact closing | Apertura contatto Contact opening | Potenza continua max Max continuous power | Potenza max 2 min. Max power 2 min. | Potenza max 5 sec. Max power 5 sec. | ↑ mm. | Perni filettati Pins | kg. |
|-----------------|-------|-------|------------------|-----------------------------------|-----------------------------------|---|-------------------------------------|-------------------------------------|----------|----------------------|-------|
| K 10 07 610 | | 7610B | 9-36Vdc | 13,5-27V | 12,7-25,4V | 120A | 210A | 280A | 99x89x50 | M10 | 0,570 |

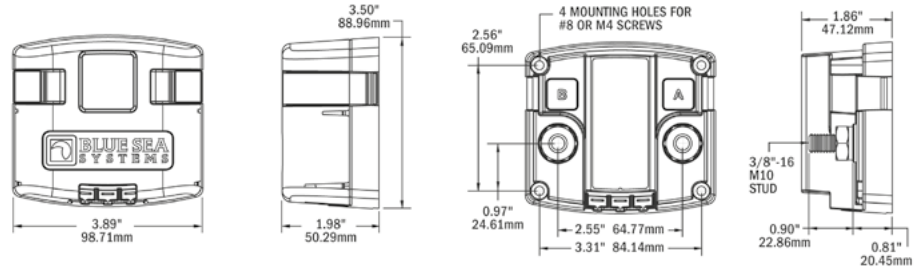

PORTAFUSIBILI | FUSES HOLDER

ST-Blade portafusibili

Permette di aggiungere facilmente fino a 4 circuiti sotto fusibile direttamente al terminale della batteria. Facile installazione di 4 circuiti ATO/ATC. Montaggio direttamente sul perno della batteria. Fornito di viti di fissaggio e 4 faston.

ST-Blade battery terminal mount fuse block

Easily add up to 4 fused circuits with insulating cover to the terminal of a battery. Provides power to new accessories in your boat or vehicle. Easy to install 4 ATO/ATC fused circuits. Mounts on the battery terminal stud. Screw terminals for securing wires. Four nylon insulated ring terminals included and insulating cover included. Accepts small Format Circuit Labels and includes 1 fuse.

| Articolo - Item | €/pc. | Mod. | Tensione Voltage V | Amperage Max. Operating/per circuit | Amperage Max. Operating/per block | Fuse type | Screw Terminal viti 8-32 c/rondezza 8-32 screws w/ washer | kg. |
|-----------------|-------|------|--------------------|-------------------------------------|-----------------------------------|------------|---|-----|
| K 12 05 023 | | 5023 | 32 | 30A | 100A | ATO or ATC | | |



TERMINALI ISOLATI AD ANELLO IN NYLON NYLON INSULATED RING TERMINALS

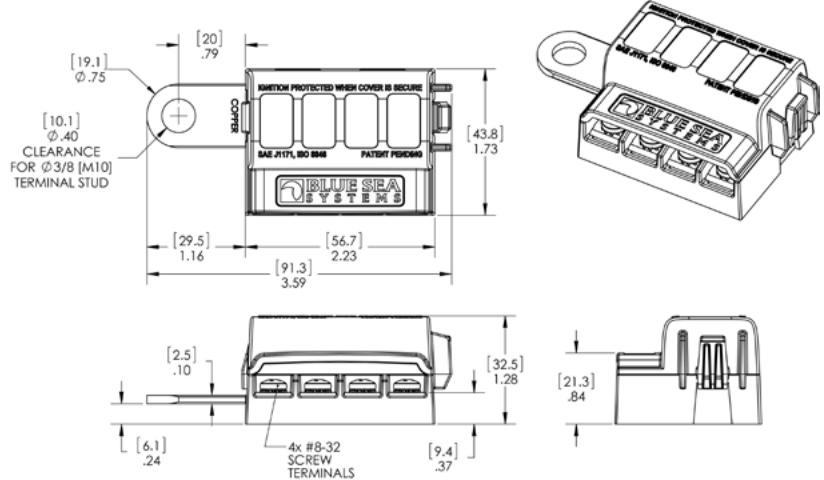

ST-Blade Kit portafusibili

Permette di aggiungere facilmente fino a 4 circuiti sotto fusibile direttamente al terminale della batteria. Facile installazione di 4 circuiti ATO/ATC. Montaggio direttamente sul perno della batteria. Fornito di viti di fissaggio e 8 faston.

ST-Blade battery terminal mount fuse block kit

Easily installed battery terminal mount 4 ATO/ATC Fuse block and negative BusBar. Easy to install 4 ATO/ATC fused circuits. Mounts on the battery terminal stud. Screw terminals for securing wires. Eight nylon ring terminals included and insulating cover included.

| Articolo - Item | €/pc. | Mod. | kg. |
|-----------------|-------|------|-----|
| K 12 05 024 | | 5024 | |

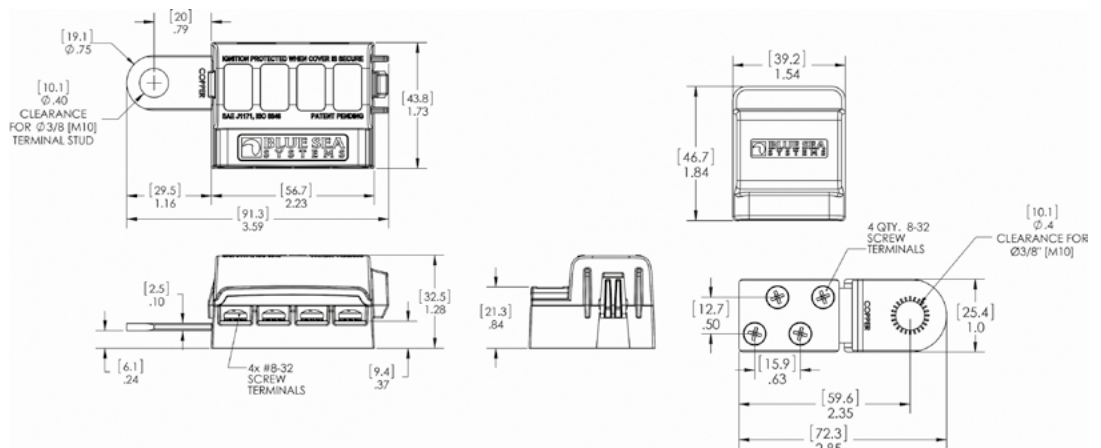

Barre doppie di connessione 150A.

Permettono di combinare negativi e positivi in un'unica barra. Viti e perno in acciaio inox. Base completamente isolata in policarbonato rinforzato. Complete di coperchio in policarbonato trasparente. Barra in rame argentato.

Dual Bus Plus 150A. common Bus bars

Secure, clear polycarbonate cover snaps on easily. Combines negative and positive buses on one block. Cover release button. Screws and pin in stainless steel. Fully isolated base made of reinforced polycarbonate.

| Articolo - Item | €/pc. | Mod. | N. vie Circuits | Sezione vite Screw section | Sezione perni Pins | Lunghezza Length mm. | Larghezza Width mm. | Amp. max Max rating AC/DC | Tensione max Max voltage AC/DC | kg. |
|-----------------|-------|------|-----------------|----------------------------|--------------------|----------------------|---------------------|---------------------------|--------------------------------|-------|
| K 05 02 722 | | 2722 | 5 | 5 mm. | M6 | 123,83 | 65,53 | 150A | 300/48V | 0,300 |



Barre di potenza 600A.

Viti e perno in acciaio inox. Base in policarbonato rinforzato. Barra in rame argentato per la massima conducibilità e resistenza alla corrosione.

Power bar 600A. common Bus bars

Highest amp rated bus bar with 3/8" terminal studs. Screws and pin in stainless steel. Bus made of tin-plated copper.

| Articolo - Item | €/pc. | Mod. | N. vie Circuits | Sezione vite Screw section | Sezione perni Pins | Lunghezza Length mm. | Larghezza Width mm. | Amp. max Max rating AC/DC | Tensione max Max voltage AC/DC | kg. |
|-----------------|-------|------|-----------------|----------------------------|--------------------|----------------------|---------------------|---------------------------|--------------------------------|-------|
| K 05 02 104 | | 2104 | 4 | - | M10 | 177,8 | 50,8 | 600A | 300/48V | 0,790 |
| K 05 02 107 | | 2107 | 8 | - | M10 | 288,93 | 50,8 | 600A | 300/48V | 1,250 |



Protezione in Abs per barre

Abs protection cover for bars

| Articolo - Item | €/pc. | Mod. | Per barre - For bars | kg. |
|-----------------|-------|------|----------------------|-------|
| K 05 02 708 | | 2708 | 2104 | 0,050 |



Minibarre di connessione 100A.

Viti e perno in acciaio inox. Base completamente isolata in Abs. Particolarmente indicate per applicazioni con spazi limitati.

Mini Bus 100A. common bus bars

Provides convenient busing for limited space applications. Fully isolated base in Abs. Screws and pins in stainless steel.

| Articolo - Item | €/pc. | Mod. | N. vie Circuits | Sezione vite Screw section | Sezione perni Pins | Lunghezza Length mm. | Larghezza Width mm. | Amp. max Max rating AC/DC | Tensione max Max voltage AC/DC | kg. |
|-----------------|-------|------|-----------------|----------------------------|--------------------|----------------------|---------------------|---------------------------|--------------------------------|-------|
| K 05 02 304 | | 2304 | 5 | 4 mm. | M5 | 106,68 | 22,86 | 100A | 300/48V | 0,070 |
| K 05 02 305 | | 2305 | 4 | - | M5 | 106,68 | 22,86 | 100A | 300/48V | 0,070 |
| K 05 02 306 | | 2306 | 6 | 4 mm. | - | 95,25 | 12,7 | 100A | 300/48V | 0,050 |



Barre doppie di connessione 100A.

Permettono di combinare negativi e positivi in un'unica barra. Viti e perno in acciaio inox. Base completamente isolata in Abs. Barra in rame argentato per la massima conducibilità e resistenza alla corrosione.

Dual Bus 100A. common Bus bars

Combines two buses on one block. Combines negative and positive buses for DC Systems and neutral and ground buses for AC Systems. Fully isolated base in Abs. Screws and pins in stainless steel. Bus made of tin-plated copper.

| Articolo - Item | €/pc. | Mod. | N. vie Circuits | Sezione vite Screw section | Sezione perni Pins | Lunghezza Length mm. | Larghezza Width mm. | Amp. max Max rating AC/DC | Tensione max Max voltage AC/DC | kg. |
|-----------------|-------|------|-----------------|----------------------------|--------------------|----------------------|---------------------|---------------------------|--------------------------------|-------|
| K 05 02 701 | | 2701 | 5x2 | 4 mm. | - | 76,5 | 46,48 | 100A | 300/48V | 0,100 |
| K 05 02 702 | | 2702 | 10x2 | 4 mm. | - | 128,52 | 46,48 | 100A | 300/48V | 0,140 |



Barre di connessione 150A.

Base in nylon rinforzato. Viti e perno in acciaio inox. Barra in rame argentato per la massima conducibilità e resistenza alla corrosione.

150A. common Bus bars

Insert-molded stainless steel stud eliminates need for securing nut and allows high torquing for excellent electrical contact.

| Articolo - Item | €/pc. | Mod. | N. vie Circuits | Sezione vite Screw section | Sezione perni Pins | Lunghezza Length mm. | Larghezza Width mm. | Amp. max Max rating AC/DC | Tensione max Max voltage AC/DC | kg. |
|-----------------|-------|------|-----------------|----------------------------|--------------------|----------------------|---------------------|---------------------------|--------------------------------|-------|
| K 05 02 301 | | 2301 | 10 | 4 mm. | M6 | 149,22 | 31,75 | 130/150A | 300/48V | 0,150 |
| K 05 02 302 | | 2302 | 20 | 4 mm. | M6 | 231,78 | 31,75 | 130/150A | 300/48V | 0,230 |
| K 05 02 303 | | 2303 | 4 | - | M6 | 149,22 | 31,75 | 130/150A | 300/48V | 0,160 |



K0502301-302



K0502303

Protezione in Abs per minibarre

Abs cover for Mini Bus

| Articolo - Item | €/pc. | Mod. | Per barre - For bars | kg. |
|-----------------|-------|------|----------------------|-------|
| K 05 02 715 | | 2715 | 2301-2303 | 0,040 |



PORTAFUSIBILI | FUSES HOLDER

Portafusibili per polo batteria

Si installano direttamente sul polo della batteria. Portano fusibili da 30A. a 300A. Particolarmente indicati per salpa ancora, eliche di manovra, inverter. Versione ad 1 porta fusibile. Versione a 2 porta fusibili. Cappuccio di protezione in gomma rosso.

Terminal fuse blocks

Satisfies ABYC 7" circuit protection rule by mounting on a 3/8" battery post, battery switch, or bus bar. Appropriate for DC Main, inverter, windlass, and bow thruster circuit protection. Weatherproof—suitable for small open-cockpit boats and other harsh environments. Insulating cap prevents accidental shorts.

| Articolo - Item | €/pc. | Mod. | Portafusibili Fuses holder | Tensione max Max voltage | Potenza max A Max power A | Fusibili dedicati Terminal fuses av | Perni Pins M6 | Foro fissaggio batt Mounting hole mm. | mm. | kg. |
|-----------------|-------|------|----------------------------|--------------------------|---------------------------|-------------------------------------|---------------|---------------------------------------|----------|-------|
| K 12 05 191 | | 5191 | 1 | 58V | 300A | 30-300A | 1 | Ø 13,5 mm. | 20x61x45 | 0,070 |

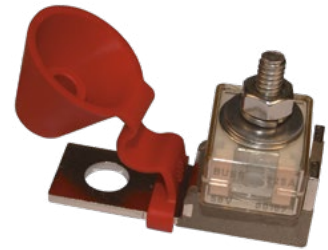

Pannello portafusibili ATO/ATC

Per fusibili ATO/ATC. Realizzato in robustissimo policarbonato rinforzato. Barre e contatti in rame argentato. Barra di distribuzione polo negativo inclusa. Copertura isolata. Perno +/- bulloni 5 mm.

ATO/ATC blade fuse blocks screw terminal

Compact ATO/ATC fuse block consolidates branch circuits and eliminates the tangle of in-line fuses. Made of very strong reinforced polycarbonate. Tin-plated copper buses and fuse clips. Fuse Blocks with covers include 20 write-on circuit labels.

| Articolo - Item | €/pc. | Mod. | N. vie - Circuits | Potenza totale Full power | Attacchi Fittings | Massa Ground | mm. | kg. |
|-----------------|-------|------|--------------------|---------------------------|-------------------|--------------|----------|-------|
| K 12 05 025 | | 5025 | 6 circuiti + massa | max 100A | vite-screw 4 mm. | No | 84x93x39 | 0,250 |
| K 12 05 028 | | 5028 | 6 circuiti | max 100A | vite-screw 4 mm. | Si - Yes | 84x93x39 | 0,190 |



Pannello portafusibili ATO/ATC

Per fusibili ATO/ATC. Realizzato in robustissimo policarbonato rinforzato. Barre e contatti in rame argentato. Barra di distribuzione polo negativo inclusa. Copertura isolata. Perno +/- bulloni 5 mm.

ATO/ATC blade fuse blocks screw terminal

Compact ATO/ATC fuse block consolidates branch circuits and eliminates the tangle of in-line fuses. Made of very strong reinforced polycarbonate. Tin-plated copper buses and fuse clips. Fuse Blocks with covers include 20 write-on circuit labels.

| Articolo - Item | €/pc. | Mod. | N. vie - Circuits | Potenza totale Full power | Attacchi Fittings | Massa Ground | mm. | kg. |
|-----------------|-------|------|---------------------|---------------------------|-------------------|--------------|-----------|-------|
| K 12 05 026 | | 5026 | 12 circuiti + massa | max 100A | vite-screw 4 mm. | No | 84x164x39 | 0,340 |
| K 12 05 029 | | 5029 | 12 circuiti | max 100A | vite-screw 4 mm. | Si - Yes | 84x164x39 | 0,310 |





Fusibili in vetro 6,3 x 32 AGC

AGC 6,3 x 32 fast acting glass fuses

| Articolo - Item | €/box | Mod. | Potenza Power | DC Volts | AC Volts | ↑ mm. | pcs. | kg. |
|-----------------|-------|-------|---------------|----------|----------|----------|------|-------|
| K 11 05 204 | | 5204B | 1A | 9 - 32V | 250V | 6,3 x 32 | 10 | 0,250 |
| K 11 05 206 | | 5206B | 2A | 9 - 32V | 250V | 6,3 x 32 | 10 | 0,250 |
| K 11 05 208 | | 5208B | 3A | 9 - 32V | 250V | 6,3 x 32 | 10 | 0,250 |
| K 11 05 209 | | 5209B | 4A | 9 - 32V | 250V | 6,3 x 32 | 10 | 0,250 |
| K 11 05 210 | | 5210B | 5A | 9 - 32V | 250V | 6,3 x 32 | 10 | 0,250 |
| K 11 05 212 | | 5212B | 7A | 9 - 32V | 250V | 6,3 x 32 | 10 | 0,250 |
| K 11 05 219 | | 5219B | 25A | 9 - 32V | 250V | 6,3 x 32 | 10 | 0,250 |

Fusibili a lama «Maxi Fuses»

Blade-type «Maxi» fuses



| Articolo - Item | €/pc. | Mod. | Potenza Power | DC Volts | pcs. | kg. |
|-----------------|-------|------|---------------|----------|------|-------|
| K 11 05 138 | | 5138 | 30A | 9 - 32V | 1 | 0,020 |
| K 11 05 139 | | 5139 | 40A | 9 - 32V | 1 | 0,020 |

Fusibili ANL

ANL fuses

| Articolo - Item | €/pc. | Mod. | Potenza Power Amp. | Tensione Voltage | Capacità interruzione Interrupting capacity | ↑ mm. | Int. fori Holes distance mm. | pcs. | kg. |
|-----------------|-------|------|--------------------|------------------|---|-----------|------------------------------|------|-------|
| K 11 05 122 | | 5122 | 50 | 9 - 32V | 6000A | 80,9x22,6 | 61,72 | 1 | 0,030 |
| K 11 05 123 | | 5123 | 60 | 9 - 32V | 6000A | 80,9x22,6 | 61,72 | 1 | 0,030 |
| K 11 05 124 | | 5124 | 80 | 9 - 32V | 6000A | 80,9x22,6 | 61,72 | 1 | 0,020 |
| K 11 05 125 | | 5125 | 100 | 9 - 32V | 6000A | 80,9x22,6 | 61,72 | 1 | 0,020 |
| K 11 05 126 | | 5126 | 130 | 9 - 32V | 6000A | 80,9x22,6 | 61,72 | 1 | 0,040 |
| K 11 05 127 | | 5127 | 150 | 9 - 32V | 6000A | 80,9x22,6 | 61,72 | 1 | 0,040 |
| K 11 05 128 | | 5128 | 175 | 9 - 32V | 6000A | 80,9x22,6 | 61,72 | 1 | 0,040 |
| K 11 05 129 | | 5129 | 200 | 9 - 32V | 6000A | 80,9x22,6 | 61,72 | 1 | 0,040 |
| K 11 05 131 | | 5131 | 250 | 9 - 32V | 6000A | 80,9x22,6 | 61,72 | 1 | 0,040 |
| K 11 05 133 | | 5133 | 300 | 9 - 32V | 6000A | 80,9x22,6 | 61,72 | 1 | 0,030 |
| K 11 05 135 | | 5135 | 350 | 9 - 32V | 6000A | 80,9x22,6 | 61,72 | 1 | 0,030 |
| K 11 05 136 | | 5136 | 400 | 9 - 32V | 6000A | 80,9x22,6 | 61,72 | 1 | 0,040 |
| K 11 05 137 | | 5137 | 500 | 9 - 32V | 6000A | 80,9x22,6 | 61,72 | 1 | 0,050 |

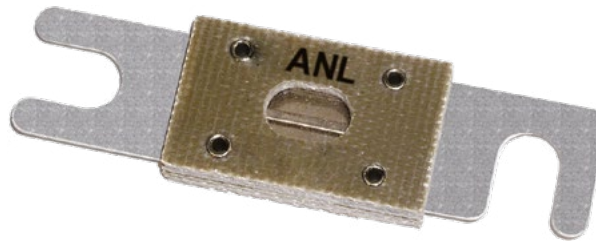

Fusibili Mega - Val

Mega - Val fuses

| Articolo - Item | €/pc. | Mod. | Potenza Power Amp. | Tensione Voltage | Capacità interruzione Interrupting capacity | ↑ mm. | Interasse fori Holes distance mm. | Colore Colour | pcs. | kg. |
|-----------------|-------|------|--------------------|------------------|---|-----------|-----------------------------------|---------------|------|-------|
| K 11 05 101 | | 5101 | 100 | 9 - 32V | 2000A | 68,6x19,1 | 50,8 | Yellow | 1 | 0,030 |
| K 11 05 102 | | 5102 | 125 | 9 - 32V | 2000A | 68,6x19,1 | 50,8 | Sky blue | 1 | 0,030 |
| K 11 05 103 | | 5103 | 150 | 9 - 32V | 2000A | 68,6x19,1 | 50,8 | Orange | 1 | 0,030 |
| K 11 05 104 | | 5104 | 175 | 9 - 32V | 2000A | 68,6x19,1 | 50,8 | White | 1 | 0,030 |
| K 11 05 105 | | 5105 | 200 | 9 - 32V | 2000A | 68,6x19,1 | 50,8 | Blue | 1 | 0,030 |
| K 11 05 107 | | 5107 | 250 | 9 - 32V | 2000A | 68,6x19,1 | 50,8 | Pink | 1 | 0,030 |

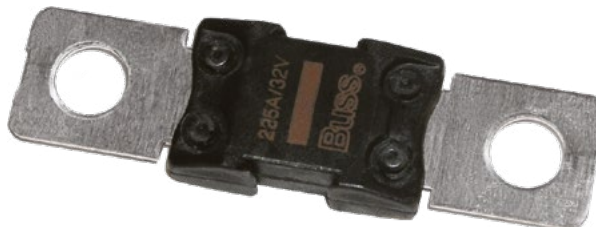

Fusibili «Midi»

Ideali per proteggere i circuiti principali: salpa ancora, eliche, inverter.
Codifica colorata per una semplice identificazione dell'ampérage.

«Midi» fuses

Compact fuse for main or branch 30 to 200A. circuit protection.
Clear window offers visible indication of blown condition.
Color-coded for easy amperage identification.

| Articolo - Item | €/Pair | Mod. | Potenza Power | Tensione Voltage max | Capacità interruzione Interrupting capacity 12Vdc | ↑ mm. | Int. fori mm. Holes distance mm. | Colore Colour | kg. |
|-----------------|--------|------|---------------|----------------------|---|----------|----------------------------------|---------------|-------|
| K 11 05 250 | | 5250 | 30A | 9 - 32V | 5000 | 44x12,35 | 30 | Orange | 0,020 |
| K 11 05 251 | | 5251 | 40A | 9 - 32V | 5000 | 44x12,35 | 30 | Green | 0,020 |
| K 11 05 252 | | 5252 | 50A | 9 - 32V | 5000 | 44x12,35 | 30 | Red | 0,020 |
| K 11 05 253 | | 5253 | 60A | 9 - 32V | 5000 | 44x12,35 | 30 | Yellow | 0,020 |
| K 11 05 254 | | 5254 | 70A | 9 - 32V | 5000 | 44x12,35 | 30 | Brown | 0,020 |
| K 11 05 255 | | 5255 | 80A | 9 - 32V | 5000 | 44x12,35 | 30 | White | 0,020 |
| K 11 05 256 | | 5256 | 100A | 9 - 32V | 5000 | 44x12,35 | 30 | Blue | 0,020 |
| K 11 05 257 | | 5257 | 125A | 9 - 32V | 5000 | 44x12,35 | 30 | Pink | 0,020 |
| K 11 05 258 | | 5258 | 150A | 9 - 32V | 5000 | 44x12,35 | 30 | Light Blue | 0,020 |
| K 11 05 259 | | 5259 | 175A | 9 - 32V | 5000 | 44x12,35 | 30 | Tan | 0,020 |
| K 11 05 260 | | 5260 | 200A | 9 - 32V | 5000 | 44x12,35 | 30 | Purple | 0,020 |



Fusibili dedicati (30-300A.)

Terminal fuses

| Articolo - Item | €/pc. | Mod. | Potenza Power | Tensione Voltage | Capacità interruzione Interrupting capacity 14Vdc | Capacità interruzione Interrupting capacity 32Vdc | Foro perno Pin hole mm. | ↑ mm. | kg. |
|-----------------|-------|------|---------------|------------------|---|---|-------------------------|--------------|-------|
| K 11 05 175 | | 5175 | 30A | 9 - 32V | 10000A | 5000A | 8,3 | 27,8x23x16,3 | 0,030 |
| K 11 05 176 | | 5176 | 40A | 9 - 32V | 10000A | 5000A | 8,3 | 27,8x23x16,3 | 0,030 |
| K 11 05 177 | | 5177 | 50A | 9 - 32V | 10000A | 5000A | 8,3 | 27,8x23x16,3 | 0,030 |
| K 11 05 178 | | 5178 | 60A | 9 - 32V | 10000A | 5000A | 8,3 | 27,8x23x16,3 | 0,030 |
| K 11 05 180 | | 5180 | 75A | 9 - 32V | 10000A | 5000A | 8,3 | 27,8x23x16,3 | 0,030 |
| K 11 05 181 | | 5181 | 80A | 9 - 32V | 10000A | 5000A | 8,3 | 27,8x23x16,3 | 0,030 |
| K 11 05 182 | | 5182 | 90A | 9 - 32V | 10000A | 5000A | 8,3 | 27,8x23x16,3 | 0,030 |
| K 11 05 183 | | 5183 | 100A | 9 - 32V | 10000A | 5000A | 8,3 | 27,8x23x16,3 | 0,030 |
| K 11 05 184 | | 5184 | 125A | 9 - 32V | 10000A | 5000A | 8,3 | 27,8x23x16,3 | 0,030 |
| K 11 05 185 | | 5185 | 150A | 9 - 32V | 10000A | 5000A | 8,3 | 27,8x23x16,3 | 0,030 |
| K 11 05 187 | | 5187 | 200A | 9 - 32V | 10000A | 5000A | 8,3 | 27,8x23x16,3 | 0,030 |
| K 11 05 189 | | 5189 | 250A | 9 - 32V | 10000A | 5000A | 8,3 | 27,8x23x16,3 | 0,030 |
| K 11 05 190 | | 5190 | 300A | 9 - 32V | 10000A | 5000A | 8,3 | 27,8x23x16,3 | 0,030 |



PORTAFUSIBILI | FUSES HOLDER

Portafusibili volanti «Blue Sea»

Per fusibili in vetro 6,3x32 mm.
Portata massima 30A.

Crimpable in-line fuse holder «Blue Sea»

For use with 6,3x32 mm. glass fuses.
Max fuse amperage: 30A.

| Articolo - Item | €/pc. | Mod. | Waterproof | Potenza Power | Tensione Voltage | kg. |
|-----------------|-------|------|------------|---------------|------------------|-------|
| K 12 05 060 | | 5060 | No | 30A | 9 - 32V | 0,010 |
| K 12 05 061 | | 5061 | Si - Yes | 30A | 9 - 32V | 0,010 |



Portafusibile stagno da pannello

Per fusibili in vetro 6,3x32 mm.
Grado di protezione IP 66.

Water resistant fuse holder for panel

For use with 6,3x32 mm. glass fuses.
IP 66 protection.

| Articolo - Item | €/pc. | Mod. | Potenza Power | Tensione Voltage | ↑ mm. | Attacchi Fittings | Foro incasso Hole mm. | kg. |
|-----------------|-------|------|---------------|------------------|-------|-------------------|-----------------------|-------|
| K 12 05 021 | | 5021 | 1-35A | 9 - 32V | 15x53 | Faston | 12,70 | 0,010 |



Portafusibili ST-Blade

Blocco fusibile compatto. Ideale per fusibili a lama ATO & ATC. Ingresso cavi da un solo lato per limitare l'ingombro. Accensione protetta ISO8846 e SAE J1171 per utilizzo in camera motori. Coperchio isolato a norma ABYC/USCG. In rame stagnato. Compatibile con terminali a forcella o anello. Include etichette. Fusibili venduti separatamente.

ST-Blade compact fuse blocks

Compact common source fuse block. Accepts ATO and ATC fast acting blade fuses. Single side design allows wire entry from one side to minimize footprint. Ignition Protected-meets ISO 8846 and SAE J1171 for use in a gasoline engine compartment. Insulating cover meets ABYC/USCG insulation requirements. Tin-plated copper buses and fuse clips. Accepts ring or snap fork type terminals. Small format standard and custom labels available. Includes write-on circuit labels. Fuses sold separately.

| Articolo - Item | €/pc. | Mod. | Voltage max operating | Amperage max operating | Fusibile tipo Fuse type | Terminal/Mounting Screw | Circuiti Circuits | Copertura Cover | kg. |
|-----------------|-------|--------|-----------------------|---------------------------|-------------------------|--|-------------------|---------------------|-------|
| K 12 05 045 | | A-5045 | 32V DC | 30A/circuit 100A/block | ATO / ATC | 8-32 screws w/captive star lock washer | 4 | Inclusa Included | 0,110 |
| K 12 05 046 | | B-5046 | 32V DC | 30A/circuit 100A/block | ATO / ATC | 8-32 screws w/captive star lock washer | 8 | Inclusa Included | 0,180 |

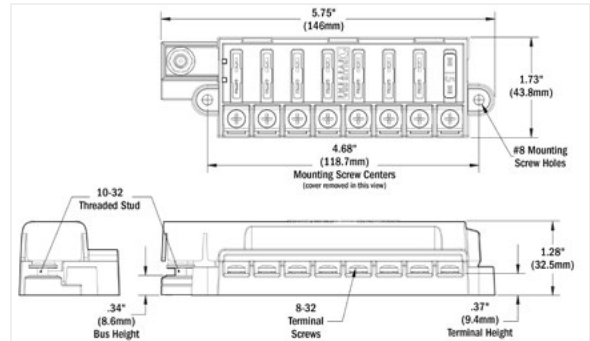
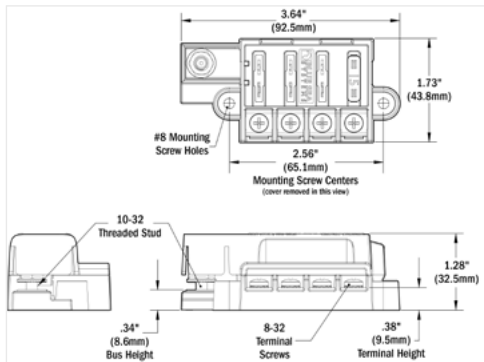

Porta interruttori automatici ST-CLB

Con una superficie compatta garantisce un montaggio a vite sicuro.

- Copertura isolante e trasparente con spazio per etichette, omologata ABYC/USCG
- Terminali a vite in rame stagnato
- Le aperture consentono accesso ai cavi in due direzioni
- Possibilità di montaggio terminali ad anello
- Possibilità di installare i bottoni sopra il coperchio
- Predisposta per etichette quadrate
- Stacca batteria venduto separatamente

ST-CLB Circuit breaker blocks

Compact surface mount solution providing secure screw termination where Push Button Reset-Only CLB Circuit Breakers are desired.

- Clear insulating cover with square format label recesses, satisfies ABYC/USCG insulation requirements
- Quick connect clips allow circuit breakers to snap easily into place
- Tin-plated copper busses and screw terminals
- Breakouts allow wire access in two directions
- Accepts ring terminals
- Optional push button waterproof boots or dress nuts can be installed over cover
- Accepts square labels
- Optional jumper K1602129/137
- Circuit breakers sold separately

Specifiche tecniche:

- Amperaggio massimo: 40A - 100A
- Temperatura di funzionamento: -10° C a 60° C
- Tipo di interruttore: solo pulsante reset con terminali Quick Connect
- Morsetto a vite: #8-32 viti con rondella di bloccaggio a stella
- Morsetto ad anello: #8 (M4), #10(M5)
- Montaggio: #8 M4 or #8 dadi

Specifications

- Amperage Max Operating: 100A (per block-common source)
- Amperage Max Operating: 40A (per jumped circuit group-independent source)
- Temp. Operating Range: -10°C to 60°C
- Breaker Type: Push Button Reset-Only Circuit Breaker with Quick Connect Terminals
- Screw Terminal: #8-32 Screws with Captive Star Lock Washer
- Ring Terminals: Screw Terminals #8(M4), Negative Bus #10(M5)
- Mounting: #8 Screw (M4) or #8 Nut

| Articolo - Item | €/pc. | Voltage max operating | Amperage max operating | Positions | Source | (A) Mounting Centers mm. | (B) Mounting Centers mm. | (C) Height mm. |
|-----------------|-------|-----------------------|------------------------|-----------|-------------|--------------------------|--------------------------|----------------|
| K 31 05 050 | | 32V DC | 32A (per circuit) | 6 | Independent | 5,63 | 1,40 | 6,69 |
| K 31 05 051 | | 32V DC | 32A (per circuit) | 12 | Independent | 10,13 | 1,71 | 11,19 |

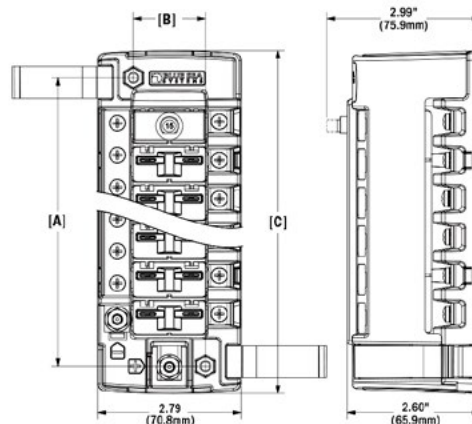

Porta fusibile per fusibili Megaval

Ingresso cavi a 180°.
Coperchio isolante conforme alle normative ABYC/USCG.
Perni in acciaio inox resistenti alla corrosione e al forte serraggio.
Base resistente ad alte temperature (UL 94-V0).

Safety fuse block

Sealed cover protects fuses from the harsh marine environment and satisfies ABYC/USCG insulation requirements.
Cover breakouts allow wire access in three directions.
Stainless steel studs provide resistance to corrosion and high torque. High temperature resistant base (UL 94-V0).

| Articolo - Item | €/pc. | Mod. | Fusibile tipo Fuse type | Potenza Power A | Tensione Voltage V | Terminali Terminal stud | Serraggio max Screw torque Nm | ↑ mm. | kg. |
|-----------------|-------|------|----------------------------|--------------------|-----------------------|----------------------------|----------------------------------|-----------|-------|
| K 12 07 721 | | 7721 | Mega-Val | 100-300A | 32V | 2xM8 | 12,40 Nm | 103x38x42 | 0,200 |



Porta fusibile per fusibili ANL (35-300A.)

Ingresso cavi a 180°.
Coperchio isolante conforme alle normative ABYC/USCG.
Perni in acciaio inox resistenti alla corrosione e al forte serraggio.
Base resistente ad alte temperature (UL 94-V0).

ANL fuse block

Sealed cover protects fuses from the harsh marine environment and satisfies ABYC/USCG insulation requirements.
Cover breakouts allow wire access in three directions.
Stainless steel studs provide resistance to corrosion and high torque. High temperature resistant base (UL 94-V0).

| Articolo - Item | €/pc. | Mod. | Fusibile tipo Fuse type | Potenza Power A | Tensione Voltage V | Terminali Terminal stud | Serraggio max Screw torque Nm | ↑ mm. | kg. |
|-----------------|-------|------|----------------------------|--------------------|-----------------------|----------------------------|----------------------------------|-----------|-------|
| K 12 05 005 | | 5005 | ANL | 35-300A | 32V | 2xM8 | 12,40 Nm | 114x38x42 | 0,160 |



Porta fusibile per fusibili ANL (35-750A.)

Ingresso cavi a 180°.
Coperchio isolante conforme alle normative ABYC/USCG.
Perni in acciaio inox resistenti alla corrosione e al forte serraggio.
Base resistente ad alte temperature (UL 94-V0).

ANL fuse block (35-750A.)

Sealed cover protects fuses from the harsh marine environment and satisfies ABYC/USCG insulation requirements.
Cover breakouts allow wire access in three directions.
Stainless steel studs provide resistance to corrosion and high torque. High temperature resistant base (UL 94-V0).

| Articolo - Item | €/pc. | Mod. | Fusibile tipo Fuse type | Potenza Power A | Tensione Voltage V | Terminali Terminal stud | Serraggio max Screw torque Nm | ↑ mm. | kg. |
|-----------------|-------|------|----------------------------|--------------------|-----------------------|----------------------------|----------------------------------|-----------|-------|
| K 12 05 503 | | 5503 | ANL | 35-750A | 32V | 4xM8 | 12,09 Nm | 178x51x58 | 0,500 |



Porta fusibile per fusibili Class T (225-400A.)

Ingresso cavi a 180°.
Coperchio isolante conforme alle normative ABYC/USCG.
Perni in acciaio inox resistenti alla corrosione e al forte serraggio.
Base resistente ad alte temperature (UL 94-V0).

Class T fuse block (225-400A.)

Sealed cover protects fuses from the harsh marine environment and satisfies ABYC/USCG insulation requirements.
Cover breakouts allow wire access in three directions.
Stainless steel studs provide resistance to corrosion and high torque. High temperature resistant base (UL 94-V0).

| Articolo - Item | €/pc. | Mod. | Fusibile tipo Fuse type | Potenza Power A | Tensione Voltage V | Terminali Terminal stud | Serraggio max Screw torque Nm | ↑ mm. | kg. |
|-----------------|-------|------|----------------------------|--------------------|-----------------------|----------------------------|----------------------------------|-----------|-------|
| K 12 05 502 | | 5502 | Class T | 225-400A | 160V | 4xM10 | 21,47 Nm | 178x51x58 | 0,500 |



Magnetotermici «Heavy Duty» IP 66

Studiati per utilizzo nautico. Resistenti all'ambiente salmastro. Contatti bimetallici e perni di grossa sezione. Unico comando di azionamento ON/OFF. Resistente alle vibrazioni. Sistema anti deflagrante. Utile per installazioni vicino a motori a benzina. Temperatura di esercizio: -25° C + 82° C. Certificazione CE.

IP 66 «Heavy Duty» circuit breakers

Specially designed for marine use. Provides medium duty circuit protection for 25 to 150 Amp loads when switching and circuit protection are both required. Single lever operation. Trip-free cannot be held closed after trip. Recessed mounting holes for clean appearance. Working temperature -25° C + 82° C. CE marked.

| Articolo - Item | €/pc. | Mod. | Potenza max Max power A | Potere di interr A Interrupting capacity | Tensione max Max voltage Vdc | Poli N. Poles N. | mm. | Perni Pins mm. | kg. |
|-----------------|-------|-------|----------------------------|---|---------------------------------|---------------------|----------------|-------------------|-------|
| K 13 07 136 | | 7136B | 30A | 5000A | 48Vdc | 1 | 87,35x59x45,64 | 8 | 0,260 |
| K 13 07 138 | | 7138B | 40A | 5000A | 48Vdc | 1 | 87,35x59x45,64 | 8 | 0,260 |
| K 13 07 139 | | 7139B | 50A | 5000A | 48Vdc | 1 | 87,35x59x45,64 | 8 | 0,260 |
| K 13 07 140 | | 7140B | 60A | 5000A | 48Vdc | 1 | 87,35x59x45,64 | 8 | 0,260 |
| K 13 07 141 | | 7141B | 70A | 5000A | 48Vdc | 1 | 87,35x59x45,64 | 8 | 0,260 |
| K 13 07 142 | | 7142B | 80A | 5000A | 48Vdc | 1 | 87,35x59x45,64 | 8 | 0,260 |
| K 13 07 146 | | 7146B | 120A | 5000A | 48Vdc | 1 | 87,35x59x45,64 | 8 | 0,260 |

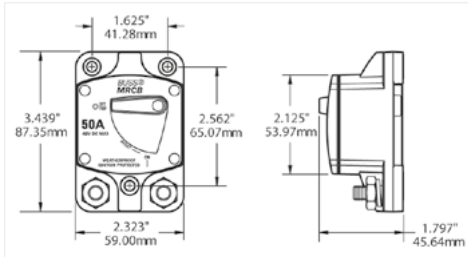

Magnetotermici Heavy Duty da incasso rotondo

Per soluzioni ad incasso (foro tondo da 53,5 mm). Studiati per utilizzo nautico. Resistenti all'ambiente salmastro. Contatti bimetallici e perni di grossa sezione. Unico comando di azionamento ON/OFF. Resistente alle vibrazioni. Sistema anti deflagrante. Utile per installazioni vicino a motori a benzina. Temperatura di esercizio: -25° C + 82° C. Certificazione CE.

Round case «Heavy Duty» circuit breakers

Round case for easy installation with hole 53,5 mm. Specially designed for marine use. Provides medium duty circuit protection for 25 to 150 Amp loads when switching and circuit protection are both required. Single lever operation. Trip-free cannot be held closed after trip. Recessed mounting holes for clean appearance. Working temperature -25° C + 82° C. CE marked.

| Articolo - Item | €/pc. | Mod. | Potenza max Max power A | Potere di interr A Interrupting capacity | Tensione max Max voltage Vdc | Poli N. Poles N. | mm. | Perni Pins mm. | kg. |
|-----------------|-------|-------|----------------------------|---|---------------------------------|---------------------|-----------------|-------------------|-------|
| K 13 07 038 | | 7038B | 40A | 5000A | 48Vdc | 1 | 69,85x53,5x44,5 | 8 | 0,230 |
| K 13 07 039 | | 7039B | 50A | 5000A | 48Vdc | 1 | 69,85x53,5x44,5 | 8 | 0,230 |
| K 13 07 040 | | 7040B | 60A | 5000A | 48Vdc | 1 | 69,85x53,5x44,5 | 8 | 0,230 |
| K 13 07 041 | | 7041B | 70A | 5000A | 48Vdc | 1 | 69,85x53,5x44,5 | 8 | 0,230 |
| K 13 07 042 | | 7042B | 80A | 5000A | 48Vdc | 1 | 69,85x53,5x44,5 | 8 | 0,230 |
| K 13 07 044 | | 7044B | 100A | 5000A | 48Vdc | 1 | 69,85x53,5x44,5 | 8 | 0,230 |
| K 13 07 046 | | 7046B | 120A | 5000A | 48Vdc | 1 | 69,85x53,5x44,5 | 8 | 0,230 |

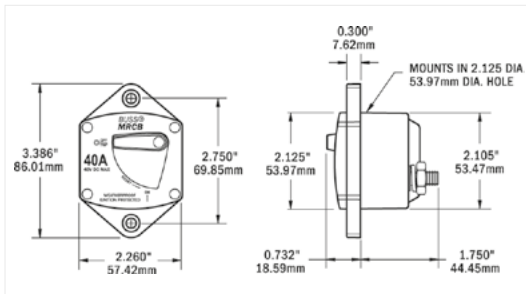

Magnetotermici IP 67

Studiati per utilizzo nautico. Resistenti all'ambiente salmastro. Doppia funzione di interruttore e di protezione termica. Sistema anti deflagrante. Utile per installazioni vicino a motori a benzina. Normalmente utilizzati come protezione di motori salpa ancore. Temperatura di esercizio: -25° C + 82° C. Certificazione CE.

IP 67 circuit breakers

Specially designed for marine use. Provides medium duty circuit protection for 25 to 150 Amp loads when switching and circuit protection are both required. Visible reset lever shows open condition. Trip-free cannot be held closed after trip. Working temperature -25° C + 82° C. CE marked.

| Articolo - Item | €/pc. | Mod. | Potenza max Max power A | Potere di interr A Interrupting capacity | Tensione max Max voltage Vdc | Poli N. Poles N. | mm. | Perni Pins mm. | kg. |
|-----------------|-------|-------|----------------------------|---|---------------------------------|---------------------|-------------------|-------------------|-------|
| K 13 07 182 | | 7182B | 40A | 3000A | 48Vdc | 1 | 56,64x48,26x45,21 | 6 | 0,230 |
| K 13 07 183 | | 7183B | 50A | 3000A | 48Vdc | 1 | 56,64x48,26x45,21 | 6 | 0,230 |
| K 13 07 184 | | 7184B | 60A | 3000A | 48Vdc | 1 | 56,64x48,26x45,21 | 6 | 0,230 |
| K 13 07 185 | | 7185B | 70A | 3000A | 48Vdc | 1 | 56,64x48,26x45,21 | 6 | 0,230 |
| K 13 07 186 | | 7186B | 80A | 3000A | 48Vdc | 1 | 56,64x48,26x45,21 | 6 | 0,230 |
| K 13 07 187 | | 7187B | 100A | 3000A | 48Vdc | 1 | 56,64x48,26x45,21 | 6 | 0,230 |
| K 13 07 188 | | 7188B | 120A | 3000A | 48Vdc | 1 | 56,64x48,26x45,21 | 6 | 0,230 |

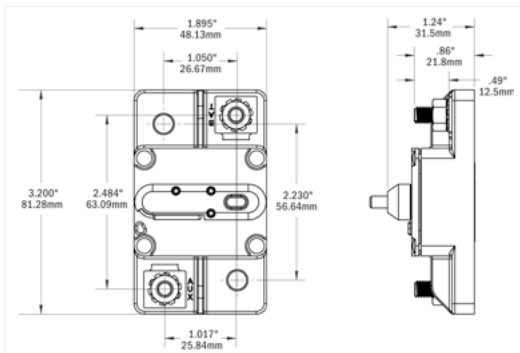

Magnetotermici da incasso quadrato

Per soluzioni ad incasso (foro 48,26 x 39,88 mm.). Studiati per utilizzo nautico. Resistenti all'ambiente salmastro. Doppia funzione di interruttore e di protezione termica. Sistema anti deflagrante.

Utile per installazioni vicino a motori a benzina. Normalmente utilizzati come protezione di motori salpa ancore. Temperatura di esercizio: -25° C + 82°C. Certificazione CE.

Square case circuit breakers

Square case for easy installation with holes 48,26 x 39,88 mm. Specially designed for marine use. Provides medium duty circuit protection for 25 to 150 Amp loads when switching and circuit protection are both required. Visible reset lever shows open condition. Trip-free cannot be held closed after trip. Working temperature -25° C + 82°C. CE marked.

| Articolo - Item | €/pc. | Mod. | Potenza max Max power A | Potere di interr A Interrupting capacity | Tensione max Max voltage Vdc | Poli N. Poles N. | mm. | Perni Pins mm. | kg. |
|-----------------|-------|-------|----------------------------|---|---------------------------------|---------------------|-------------------|-------------------|-------|
| K 13 07 083 | | 7083B | 50A | 3000A | 48Vdc | 1 | 61,21x48,26x39,88 | 6 | 0,230 |
| K 13 07 086 | | 7086B | 80A | 3000A | 48Vdc | 1 | 61,21x48,26x39,88 | 6 | 0,230 |
| K 13 07 087 | | 7087B | 100A | 3000A | 48Vdc | 1 | 61,21x48,26x39,88 | 6 | 0,230 |
| K 13 07 088 | | 7088B | 120A | 3000A | 48Vdc | 1 | 61,21x48,26x39,88 | 6 | 0,230 |
| K 13 07 089 | | 7089B | 150A | 3000A | 48Vdc | 1 | 61,21x48,26x39,88 | 6 | 0,230 |

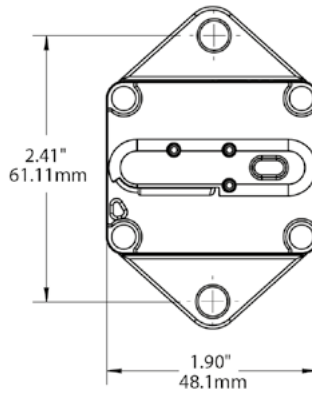

Pannello serie 360 per installazione magnetotermici da incasso quadrati **360 panel for circuit breaker mounting**

| Articolo - Item | €/pc. | Mod. | kg. |
|-----------------|-------|------|-------|
| K 32 01 477 | | 1477 | 0,330 |



FUSIBILI ELETTRONICI | ELECTRONIC FUSES

Cappuccio nero di protezione IP 67 **IP 66 black push button waterproof boot**

| Articolo - Item | €/box | Mod. | kg. |
|-----------------|-------|-------|-------|
| K 16 04 137 | | 4137B | 0,400 |



Cappuccio trasparente di protezione IP 67 **IP 67 transparent push button waterproof boot**

| Articolo - Item | €/box | Mod. | kg. |
|-----------------|-------|-------|-------|
| K 16 04 135 | | 4135B | 0,400 |



Interruttori termici a pulsante media potenza **Medium duty push button circuit breakers**

Adatti per uso in ambiente marino. Disposizione del pulsante per il ripristino. Montaggio con due viti a pannello (pannelli dedicati Blue Sea serie 360).

Suitable for marine use. Provides circuit protection for 15 to 60 Amp loads when switching is provided elsewhere or not required. Push-to-reset operation.

| Articolo - Item | €/pc. | Mod. | Potenza max Max power A | Tensione Voltage AC | Tensione Voltage DC | Capacità interruz Interrupt capacity | Perni Pins | mm. | kg. |
|-----------------|-------|------|----------------------------|---------------------|---------------------|---|---------------|----------|-------|
| K 33 02 143 | | 2143 | 60A | 120V | 32V | 5000A | M5 | 51x30x34 | 0,070 |



Magneto idraulico serie «Restricted OFF Rocker» CA≈CC

Massima sicurezza contro gli azionamenti accidentali.
 Sistema di disinserimento solo tramite l'utilizzo di un piccolo cacciavite.
 Molto indicati per sistemi con utilizzatori sotto tensione 24 ore su 24.
 Posizionabili sia in orizzontale che in verticale.
 Simboli ON/OFF con grafica internazionale.
 Viti fissaggio anteriori 3 mm.
 Contatti a vite sezione 5 mm inclinati di 45° verso l'interno.

AC≈DC «Restricted OFF Rocker» A-series circuit breakers

White actuator indicates OFF position. Single pole is available in Flat Rocker and Restricted Off styles. Restricted OFF actuator can only be switched to OFF by insertion of small screwdriver into slot. Raised Rocker actuator style is used for AC source selection on the 360 Panel System. Double pole is typically used for AC main circuit protection. International ON and OFF symbols support vertical or horizontal mounting. Front mounting screws 3 mm.

| Articolo - Item | €/pc. | Mod. | Potenza max Max rating A | Potere di inter Interrupt capacity A | Tensione max Max voltage V DC | Tensione max Max voltage V AC | Poli Poles N. | Foro incasso Mounting hole mm. | Interasse fori Holes mm. | Interasse viti Screws mm. | kg. |
|-----------------|-------|-------|-----------------------------|---|-------------------------------------|-------------------------------------|------------------|--------------------------------------|-----------------------------|------------------------------|-------|
| K 14 07 425 | | 7425B | 5 | 1500 | 32 | 250 | 1 | 32 | 19,05 | 42,16 | 0,080 |
| K 14 07 427 | | 7427B | 10 | 1500 | 32 | 250 | 1 | 32 | 19,05 | 42,16 | 0,080 |
| K 14 07 428 | | 7428B | 15 | 1500 | 32 | 250 | 1 | 32 | 19,05 | 42,16 | 0,080 |
| K 14 07 429 | | 7429B | 20 | 1500 | 32 | 250 | 1 | 32 | 19,05 | 42,16 | 0,080 |
| K 14 07 430 | | 7430B | 25 | 1500 | 32 | 250 | 1 | 32 | 19,05 | 42,16 | 0,080 |

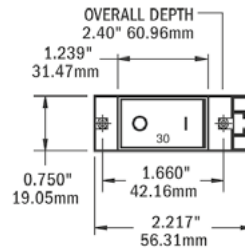

Magneto idraulico Rocker serie «Flat Rocker» CA≈CC

Alta sicurezza contro gli azionamenti accidentali.
 Molto indicati per sistemi con utilizzatori sotto tensione 24 ore su 24.
 Posizionabili sia in orizzontale che in verticale.
 Simboli ON/OFF con grafica internazionale.
 Viti fissaggio anteriori 3 mm. Contatti a vite sezione 5 mm inclinati di 45° verso l'interno.

AC≈DC «Flat Rocker» A-series single pole circuit breakers

Standard circuit breaker used on the 360 Panel System. Flat actuator resists accidental switching by being flush in the ON position. Restricted OFF actuator can only be switched to OFF by insertion of small screwdriver into slot. International ON and OFF symbols support vertical or horizontal mounting. Front mounting screws 3 mm.

| Articolo - Item | €/pc. | Mod. | Potenza max Max rating A | Potere di inter Interrupt capacity A | Tensione max Max voltage V DC | Tensione max Max voltage V AC | Poli Poles N. | Foro incasso Mounting hole mm. | Interasse fori Holes mm. | Interasse viti Screws mm. | kg. |
|-----------------|-------|-------|-----------------------------|---|-------------------------------------|-------------------------------------|------------------|--------------------------------------|-----------------------------|------------------------------|-------|
| K 14 07 400 | | 7400B | 5 | 1500 | 32 | 250 | 1 | 32 | 19,05 | 42,16 | 0,100 |
| K 14 07 402 | | 7402B | 10 | 1500 | 32 | 250 | 1 | 32 | 19,05 | 42,16 | 0,100 |
| K 14 07 403 | | 7403B | 15 | 1500 | 32 | 250 | 1 | 32 | 19,05 | 42,16 | 0,100 |
| K 14 07 404 | | 7404B | 20 | 1500 | 32 | 250 | 1 | 32 | 19,05 | 42,16 | 0,100 |

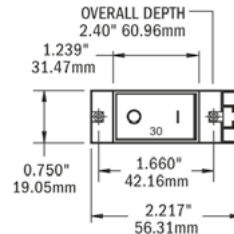

FUSIBILI ELETTRONICI | ELECTRONIC FUSES

Magneto idraulico Rocker serie «Flat Rocker» CA≈CC

Alta sicurezza contro gli azionamenti accidentali.
 Molto indicati per sistemi con utilizzatori sotto tensione 24 ore su 24.
 Posizionabili sia in orizzontale che in verticale.
 Simboli ON/OFF con grafica internazionale.
 Viti fissaggio anteriori 3 mm. Contatti a vite sezione 5 mm inclinati di 45° verso l'interno.

AC≈DC «Flat Rocker» A-series single pole circuit breakers

Standard circuit breaker used on the 360 Panel System. Flat actuator resists accidental switching by being flush in the ON position. Restricted OFF actuator can only be switched to OFF by insertion of small screwdriver into slot. International ON and OFF symbols support vertical or horizontal mounting. Front mounting screws 3 mm.

| Articolo - Item | €/pc. | Mod. | Potenza max Max power A | Tensione Voltage AC | Tensione Voltage DC | Capacità interruz Interrupt capacity | mm. | Attacchi Fittings | Foro incasso Hole mm. | kg. |
|-----------------|-------|------|----------------------------|------------------------|------------------------|---|--------------|----------------------|--------------------------|-------|
| K 16 02 130 | | 2130 | 5A | 250V | 32V | 3000A | 35x14,5x58,6 | Faston | 10 | 0,040 |
| K 16 02 132 | | 2132 | 10A | 250V | 32V | 3000A | 35x14,5x58,6 | Faston | 10 | 0,040 |
| K 16 02 133 | | 2133 | 15A | 250V | 32V | 3000A | 35x14,5x58,6 | Faston | 10 | 0,040 |
| K 16 02 134 | | 2134 | 20A | 250V | 32V | 3000A | 35x14,5x58,6 | Faston | 10 | 0,040 |
| K 16 02 135 | | 2135 | 25A | 250V | 32V | 3000A | 35x14,5x58,6 | Faston | 10 | 0,040 |
| K 16 02 136 | | 2136 | 30A | 250V | 32V | 3000A | 35x14,5x58,6 | Faston | 10 | 0,040 |
| K 16 02 137 | | 2137 | 40A | 250V | 32V | 3000A | 35x14,5x58,6 | Faston | 10 | 0,040 |



Magneto idraulico «Toggle» «A-Series» CA≈CC

Foro tondo fissaggio a pannello.
Dimensioni: 50,80 x 19,05 mm.
Temperatura d'esercizio: -40 +85°C.
Viti di fissaggio anteriori 3 mm.
Contatti a vite sezione 5 mm.

«A-series» AC≈DC single pole toggle circuit breakers

Round hole for panel mounting.
Size: 50,80 x 19,05 mm.
Working temperature: -40 +85°C.
Mounting screws: 3 mm.

LEVETTA NERA - BLACK LEVER

| Articolo - Item | €/pc. | Mod. | Potenza max Max rating A | Potere di inter Interrupt capacity A | Tensione max Max voltage V DC | Tensione max Max voltage V AC | Poli Poles N. | Foro incasso Mounting hole mm. | Interasse viti Screws mm. | kg. |
|-----------------|-------|-------|-----------------------------|---|-------------------------------------|-------------------------------------|------------------|--------------------------------------|------------------------------|-------|
| L 07 05 521 | | 7200B | 5 | 1500 | 65 | 250 | 1 | 16 | 42,16 | 0,080 |
| L 07 10 521 | | 7204B | 10 | 1500 | 65 | 250 | 1 | 16 | 42,16 | 0,080 |
| L 07 15 521 | | 7208B | 15 | 1500 | 65 | 250 | 1 | 16 | 42,16 | 0,080 |
| L 07 20 521 | | 7212B | 20 | 1500 | 65 | 250 | 1 | 16 | 42,16 | 0,080 |
| L 07 25 521 | | 7216B | 25 | 1500 | 65 | 250 | 1 | 16 | 42,16 | 0,080 |
| L 07 30 521 | | 7220B | 30 | 1500 | 65 | 250 | 1 | 16 | 42,16 | 0,080 |
| L 07 40 521 | | 7224B | 40 | 1500 | 65 | 250 | 1 | 16 | 42,16 | 0,080 |
| L 07 50 521 | | 7228B | 50 | 1500 | 65 | 250 | 1 | 16 | 42,16 | 0,080 |

LEVETTA BIANCA - WHITE LEVER

| Articolo - Item | €/pc. | Mod. | Potenza max Max rating A | Potere di inter Interrupt capacity A | Tensione max Max voltage V DC | Tensione max Max voltage V AC | Poli Poles N. | Foro incasso Mounting hole mm. | Interasse viti Screws mm. | kg. |
|-----------------|-------|-------|-----------------------------|---|-------------------------------------|-------------------------------------|------------------|--------------------------------------|------------------------------|-------|
| K 14 07 202 | | 7202B | 5 | 1500 | 65 | 250 | 1 | 16 | 42,16 | 0,080 |
| K 14 07 206 | | 7206B | 10 | 1500 | 65 | 250 | 1 | 16 | 42,16 | 0,080 |
| K 14 07 210 | | 7210B | 15 | 1500 | 65 | 250 | 1 | 16 | 42,16 | 0,080 |
| K 14 07 214 | | 7214B | 20 | 1500 | 65 | 250 | 1 | 16 | 42,16 | 0,080 |
| K 14 07 218 | | 7218B | 25 | 1500 | 65 | 250 | 1 | 16 | 42,16 | 0,080 |
| K 14 07 222 | | 7222B | 30 | 1500 | 65 | 250 | 1 | 16 | 42,16 | 0,080 |

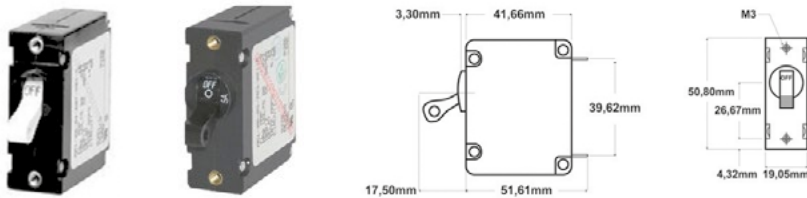

Magneto idraulico «Toggle» «A-Series» CA≈CC 2 poli

Fori tondi fissaggio a pannello.
Dimensioni: 50,80 x 38,10 mm.
Temperatura d'esercizio: -40 +85°C.
Viti di fissaggio anteriori 3 mm.
Contatti a vite sezione 5 mm.

«A-series» AC≈DC dual poles toggle circuit breakers

Round hole for panel mounting.
Size: 50,80 x 38,10 mm.
Working temperature: -40 +85°C.
Mounting screws: 3 mm.

LEVETTA NERA - BLACK LEVER

| Articolo - Item | €/pc. | Mod. | Potenza max Max rating A | Potere di inter Interrupt capacity A | Tensione max Max voltage V DC | Tensione max Max voltage V AC | Poli Poles N. | Foro incasso Mounting hole mm. | Interasse fori Holes mm. | Interasse viti Screws mm. | kg. |
|-----------------|-------|-------|-----------------------------|---|-------------------------------------|-------------------------------------|------------------|--------------------------------------|-----------------------------|------------------------------|-------|
| L 07 50 522 | | 7241B | 50 | 1500 | 65 | 250 | 2 | 2 x 16 | 19,05 | 42,16 | 0,140 |

LEVETTA BIANCA - WHITE LEVER

| Articolo - Item | €/pc. | Mod. | Potenza max Max rating A | Potere di inter Interrupt capacity A | Tensione max Max voltage V DC | Tensione max Max voltage V AC | Poli Poles N. | Foro incasso Mounting hole mm. | Interasse fori Holes mm. | Interasse viti Screws mm. | kg. |
|-----------------|-------|-------|-----------------------------|---|-------------------------------------|-------------------------------------|------------------|--------------------------------------|-----------------------------|------------------------------|-------|
| K 14 07 233 | | 7233B | 10 | 1500 | 65 | 250 | 2 | 2 x 16 | 19,05 | 42,16 | 0,140 |
| K 14 07 260 | | 7260B | 20 | 1500 | 65 | 250 | 2 | 2 x 16 | 19,05 | 42,16 | 0,140 |

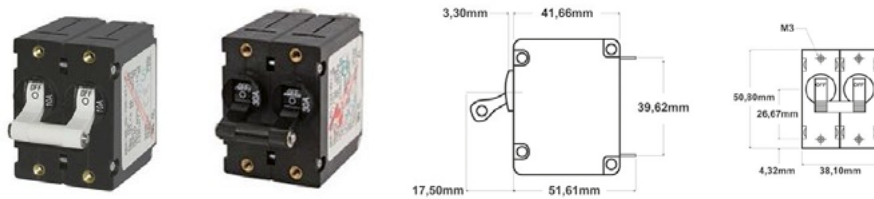

Magneto idraulico C-series «Toggle» CA≈CC

Foro rettangolare di fissaggio a pannello. Alto potere di interruzione.
Dimensioni: 63,50 x 19,05 mm. Leva di comando Bianca.
Cicli ON/OFF di vita 10.000. Viti fissaggio anteriori 3 mm.
Robusti contatti di potenza con bulloni da 6 mm.

C-series single pole AC≈DC «Toggle» circuit breakers

Rectangular hole for panel mounting. Large frame provides stud termination for 5–300 Amp loads. Provides overcurrent protection for inverters, bow thrusters, and windlasses. Offers high interrupt capacity. Front mounting screws 3 mm. Switching cycles 10.000.

| Articolo - Item | €/pc. | Mod. | Potenza max Max rating A | Potere di inter Interrupt capacity A | Tensione max Max voltage V DC | Tensione max Max voltage V AC | Poli Poles N. | Foro incasso Mounting hole mm. | Interasse fori Holes mm. | Interasse viti Screws mm. | kg. |
|-----------------|-------|-------|-----------------------------|---|-------------------------------------|-------------------------------------|------------------|--------------------------------------|-----------------------------|------------------------------|-------|
| K 14 07 246 | | 7246B | 60 | 5000 | 80 | 250 | 1 | 36,78 | 19,05 | 52,37 | 0,110 |

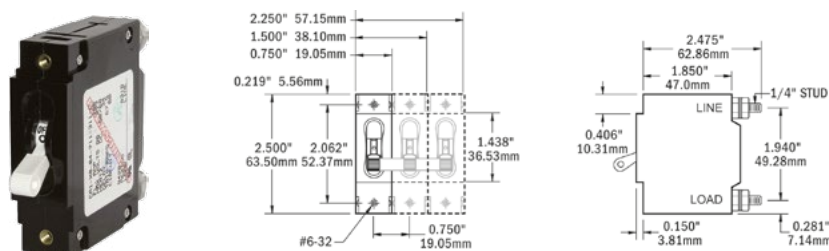

Interruttori «Carling Contura»

Completi di tasto a bascula di colore grigio senza simboli (a richiesta colore nero).
 Stagni grado di protezione IP 68.
 Realizzati in policarbonato termoplastico.
 Contatti in argento - Terminali in ottone argentato F 6,3.
 Resistenti alle vibrazioni e agli ultravioletti. Temperatura di esercizio -40° +85°C.
 Foro di montaggio 36,83 x 21,08 mm.
 Consumo Led 18 mA. Protetti con sistema antideflagrante (per uso con motori a benzina).

Water resistant «Carling Contura» switches

Specifically manufactured for use in Blue Sea Systems Contura Water Resistant Panels. Vibration, shock, thermoshock, moisture and salt spray resistant. IP 68 protection rate. Made of thermoplastic polycarbonate. Silver contacts. Silver-plated terminals F 6,3. Working temperature -40° +85°C. Mounting hole size: 36,83 x 21,08 mm. Amperage operating current 18 mA. Explosion proof for use with petrol engines.

INTERRUPTORI UNIPOLARI TASTO GRIGIO - SINGLE POLAR SWITCHES GREY KEY

| Articolo - Item | €/pc. | Mod. | Contatto elettrico Electric contact | Tensione Voltage V | Posiz interruttore Switch position | N. contatti Contacts | Carico max Load 12V-24V | Tasto Nylon Nylon key 66 | Simboli Symbols | Faston N. | Led N. | kg. |
|-----------------|-------|-------|--|-----------------------|---------------------------------------|-------------------------|----------------------------|-----------------------------|--------------------|-----------|--------|-------|
| K 15 08 234 | | 8234B | Instabile* | 12-24V | ON*-OFF-ON* | Unipolare | 20A-15A | Grigio-Grey | No | 3 | 0 | 0,040 |
| K 15 08 233 | | 8233B | Instabile* | 12-24V | ON*-OFF-ON | Unipolare | 20A-15A | Grigio-Grey | No | 4 | 1 | 0,040 |
| K 15 08 230 | | 8230B | Stabile | 12-24V | OFF-ON | Unipolare | 20A-15A | Grigio-Grey | No | 3 | 1 | 0,040 |

INTERRUPTORI BIPOLARI TASTO GRIGIO - DOUBLE POLAR SWITCHES GREY KEY

| Articolo - Item | €/pc. | Mod. | Contatto elettrico Electric contact | Tensione Voltage V | Posiz interruttore Switch position | N. contatti Contacts | Carico max Load 12V-24V | Tasto Nylon Nylon key 66 | Simboli Symbols | Faston N. | Led N. | kg. |
|-----------------|-------|-------|--|-----------------------|---------------------------------------|-------------------------|----------------------------|-----------------------------|--------------------|-----------|--------|-------|
| K 15 08 222 | | 8222B | Instabile* | 12-24V | ON*-OFF-ON* | Bipolare | 20A-15A | Grigio-Grey | No | 6 | 0 | 0,040 |
| K 15 08 221 | | 8221B | Instabile* | 12-24V | ON*-OFF-ON | Bipolare | 20A-15A | Grigio-Grey | No | 7 | 1 | 0,040 |
| K 15 08 219 | | 8219B | Instabile* | 12-24V | OFF-ON* | Bipolare | 20A-15A | Grigio-Grey | No | 4 | 0 | 0,040 |



Tasti di ricambio neri

Black spare keys

| Articolo - Item | €/pc. | Mod. | Colore - Colour | Tipo - Type | kg. |
|-----------------|-------|-------|-----------------|-------------|-------|
| K 15 08 296 | | 8296B | ■ | Cieco-Blind | 0,010 |
| K 15 08 294 | | 8294B | ■ | 1 Led | 0,010 |



Cornici per interruttori «Contura Carling»

«Contura Carling» switch mounting panels

Spessore pannello di montaggio da 0,76 a 4,76 mm.

Mounting panel thickness: 0,76 - 4,76 mm.

| Articolo - Item | €/pc. | Mod. | Misure esterne Outer size mm. | Misure interne Inner size mm. | Posizioni interruttore Switch positions | kg. |
|-----------------|-------|-------|----------------------------------|----------------------------------|--|-------|
| K 15 08 267 | | 8267B | 58x29 | 37x21 | 1 Laterale-Side | 0,040 |
| K 15 08 266 | | 8266B | 58x29 | 37x21 | 1 Centrale-Center | 0,040 |



ACCESSORI PER QUADRI | ACCESSORIES FOR ELECTRICAL PANELS

Spia luminosa Micro-Led 12-24V.

Installazione a pressione grazie allo speciale porta Led.

Micro-Led indicator light 12-24V.

Simple push-in installation mounts in any thickness material.

| Articolo - Item | €/pc. | Mod. | Colore Colour | Tensione Voltage | Ø Spia Light mm. | Ø Led mm. | Foro incasso Hole mm. | Spessore pannello Panel thickness mm. | Profondità max Max depth mm. | Contatti tipo Contacts type | kg. |
|-----------------|-------|-------|------------------|---------------------|---------------------|--------------|--------------------------|--|---------------------------------|--------------------------------|-------|
| K 33 08 171 | | 8171B | ■ Rosso | 12-24V | 5 | 3 | 4 | 1-5 | 15 | Fili-Wires | 0,010 |
| K 33 08 172 | | 8172B | ■ Verde | 12-24V | 5 | 3 | 4 | 1-5 | 15 | Fili-Wires | 0,010 |
| K 33 08 033 | | 8033B | ■ Giallo | 12-24V | 5 | 3 | 4 | 1-5 | 15 | Fili-Wires | 0,010 |

Spia luminosa Micro-Led 220V.

Installazione a pressione grazie allo speciale porta Led.

Micro-Led indicator light 220V.

Simple push-in installation mounts in any thickness material.

| Articolo - Item | €/pc. | Mod. | Colore Colour | Tensione Voltage | Ø Spia Light mm. | Ø Led mm. | Foro incasso Hole mm. | Spessore pannello Panel thickness mm. | Profondità max Max depth mm. | Contatti tipo Contacts type | kg. |
|-----------------|-------|-------|------------------|---------------------|---------------------|--------------|--------------------------|--|---------------------------------|--------------------------------|-------|
| K 33 08 166 | | 8166B | ■ Rosso | 220V | 5 | 3 | 4 | 1-5 | 15 | Fili-Wires | 0,010 |
| K 33 08 134 | | 8134B | ■ Verde | 220V | 5 | 3 | 4 | 1-5 | 15 | Fili-Wires | 0,010 |
| K 33 08 167 | | 8167B | ■ Giallo | 220V | 5 | 3 | 4 | 1-5 | 15 | Fili-Wires | 0,010 |

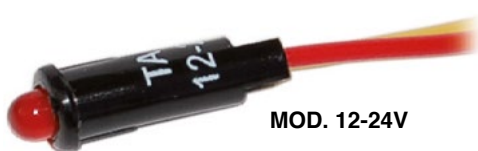

Quadri modulari serie 360 230V. CA

Versione con interruttori termici levetta nera e Flat Rocker.
 Completamente precablati. Fase, neutri e terra cablati su barre in rame argentato.
 Realizzati su pannelli modulari in robusto alluminio anodizzato. Scritte retroilluminate da led (30 in dotazione - 120 optional).
 Led di segnalazione «ON» 230V. colore verde cablati.
 Vasta gamma di magnetotermici da 5 a 50A. (a richiesta).
 Versioni dotate di strumenti analogici (Volt-Ampere).
 I quadri dotati di Generale Bipolare hanno un led rosso per indicare l'inversione di polarità.

AC 360 Combination circuit breaker panels 230V.

AC Branch panels distribute current from a high amperage input into lower amperage circuits. ON-indicating Leds in all circuit positions. Panels with voltmeters include a toggle switch to monitor voltage on up to three battery banks. Backlit label positions for select models. No exposed screws. Made on strong anodised aluminium modular panels.
 DC Digital Multimeter. DC Analog Meters.
 Amber ON-indicating Leds.
 Red reverse polarity indication Led.
 Green ON indicating Leds.

| Articolo - Item | €/pc. | Mod. | Termici installati CC | Term 8A installati | Tensione Voltage | Volt analogico Analog Volt 8-16V | Strum analog Volt Analog Volt | Multimetro digitale Digital multimeter | mm. | kg. |
|-----------------|-------|------|-----------------------|--------------------|------------------|----------------------------------|-------------------------------|--|----------------|-------|
| K 25 01 229 | | 1229 | - | 8 | 230V | - | - | - | 123,8x196,8x65 | 1,230 |



QUADRI ELETTRICI SOTTO COPERTA | BELOW DECK CIRCUIT BREAKER PANELS

Quadri elettrici sotto coperta

Below deck circuit breaker panel

| Articolo - Item | €/pc. | Mod. | Voltage in funzione Voltage Operating | Tensione DC totale max. Max. Total cont. current | Circuit breaker rating | N. vie-Circuits | mm. totali-overall | mm. taglio- cutout | kg. |
|-----------------|-------|---------|---------------------------------------|--|------------------------|---------------------------------------|--------------------|--------------------|-----|
| K 31 04 350 | | F-4350B | 12V DC Nominal | 45A | 15A | 4 | 108x145x44 | 76x130 | |
| K 31 04 352 | | G-4352B | 12V DC Nominal | 45A | 15A | 6 | 114x165x44 | 76x130 | |
| K 31 04 351 | | H-4351B | 12V DC Nominal | 45A | 15A | 4 + 2 prese 12V. 4 + 2 12V Sockets | 114x165x44 | 76x130 | |



Pannelli con commutatori a camme

Pannello in alluminio con finitura in poliuretano.
 Led rosso per indicare inversione di polarità.

Source selection rotary switch panels

Aluminium panel with polyurethane finishing.
 Panels include ON and red reverse polarity indicating led.

| Articolo - Item | €/pc. | Mod. | Corrente term nom Thermal voltage | Tens isolam nom Insulating voltage | Posiz selettore Selector position | Poli selezionati Selected poles N. | mm. | Ø max sez cavi Wire section max Ø | Ø min sez cavi Wire section min Ø | kg. |
|-----------------|-------|------|-----------------------------------|------------------------------------|-----------------------------------|------------------------------------|------------------------|-----------------------------------|-----------------------------------|-------|
| K 34 08 359 | | 8359 | 30A | 600V | 2+OFF | 2 | 133,35x95,25 x48,51 | 2,59 | 1,63 | 0,290 |
| K 34 08 358 | | 8358 | 30A | 600V | 3+OFF | 2 | 133,35x95,25 x61,21 | 2,59 | 1,63 | 0,320 |



Quadri stagni 12-24V. con fusibili

Studiati per applicazioni esterne IP 66. Dotati di fusibili in vetro 6,3 x 32 da 10A. Pannello in robusto alluminio verniciato e marinizzato. Completamente cablati e pronti per l'installazione. Interruttori a bascula «Carling Switches».

Quadri verticali: set di 30 targhette identificative incluso.

Quadri orizzontali: set di 60 targhette identificative incluso.

Led di indicazione «ON» sulla bascula degli interruttori. Bascula di colore grigio (a richiesta, a parte nera). Il Quadretto ad 1 interruttore è dedicato al comando pompa di sentina (Auto-Off-ON*).

Waterproof panels 12-24V. with fuses

IP 66 waterproof.

Designed for open-cockpit and flybridge applications using switches to complement existing controls commonly used on many boats. Equipped with glass fuses 6,3 x 32 10A. Designed for 12 or 24V DC systems.

Watertight mounting gasket. ON indicating Leds embedded in all switches.

Includes small format label set. Vertical panels (30 labels). Horizontal panels (60 labels). Panel manufactured in strong painted aluminium.

| Articolo - Item | €/pc. | Mod. | N. vie Circuits | Tipo installaz Mounting | Tipo interruttore Switch type | Tensione Voltage DC | Potenza max pannello Panel max power | Potenza interruttore Switch power 12-24V | Fusibile vetro Glass fuse 6,3x32 | mm. | kg. |
|-----------------|-------|------|-----------------|-------------------------|-------------------------------|---------------------|--------------------------------------|--|----------------------------------|------------------|-------|
| K 30 08 053 | | 8053 | 6 | Vert-Vertical | ON-OFF | 12-24V | 45A | 20A-15A | 10A | 133,3x190,5x76,2 | 0,540 |



Quadri stagni 12-24V. con protezioni termica ripristinabile

Studiati per applicazioni esterne IP 66. Dotati di protezioni termiche ripristinabili. Pannello in robusto alluminio verniciato e marinizzato. Completamente cablati e pronti per l'installazione. Interruttori a bascula «Carling Switches» ON -OFF (a richiesta, a parte, altri modelli). Led di indicazione «ON» sulla bascula degli interruttori.

Quadri bianchi: Bascula di colore grigio.

Waterproof panels 12-24V. with thermal protection

IP 66 protected for outdoor application.

«Carling Switches» ON-OFF toggle switches.

Panel manufactured in strong painted aluminium.

Fully pre-wired and ready for installation.

ON indicating Leds embedded in all switches.

White panels: grey colour toggle switch.

| Articolo - Item | €/pc. | Mod. | N. vie Circuits | Tipo installaz Installation | Tipo interruttore Switch type | Tensione Voltage DC | Potenza max pannello Panel max power | Potenza interruttore Switch power 12-24V | Protez term riprist Thermal protection | mm. | kg. |
|-----------------|-------|------|-----------------|-----------------------------|-------------------------------|---------------------|--------------------------------------|--|--|------------------|-------|
| K 31 08 272 | | 8272 | 4 | Orizz-Horiz | ON-OFF | 24V | 45A | 20A-15A | 15A | 133,3x107,9x82,5 | 0,430 |

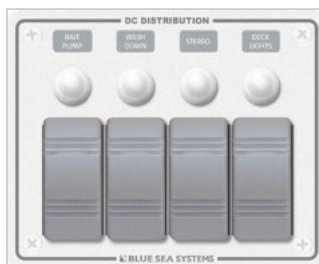

Quadri stagni 12-24V. con protezione termica ripristinabile

Solo per impianti a 12V. e 24V.

Studiati per applicazioni esterne IP 67. Posizionabili in 4 differenti orientamenti. Realizzati in speciali materiali anti-corrosione. Interruttori «Carling Switches» a levetta. Termici ripristinabili a protezione dei circuiti. Circuito indipendente retroilluminazione Led scritte. Led bicolore retroilluminazione: ON (verde). Kit di 30 targhette con scritte quadrate (posizionabili a 360°).

Sagoma anteriore studiata per evitare l'azionamento accidentale degli interruttori.

Circuit breaker panels 12-24V. with thermal protection

For 12V. and 24V. systems only.

IP 67 protected for outdoor application. Panels can be mounted in four different orientations. UV stabilized weather-resistant faceplate snaps on and off providing access to components and concealing mounting screws. «Carling Switches» lever-type switches. Integrated switch guards reduce the risk of accidental switching. Independent label backlighting allows switching and dimming. Fuse models only: bicolored Leds illuminate circuit labels to quickly identify ON (Green) circuits. Circuit breaker models only: green Leds illuminate circuit labels. Square format label set with 30 labels included.

| Articolo - Item | €/pc. | Mod. | N. vie Circuits | Tipo installaz Installation | Tipo interruttore Switch type | Tensione Voltage DC | Potenza max pannello Panel max power | Potenza interruttore Switch power 12-24V | Fusibile protez Uni-Val Fuse | mm. | kg. |
|-----------------|-------|------|-----------------|-----------------------------|-------------------------------|---------------------|--------------------------------------|--|------------------------------|------------------|-------|
| K 29 04 376G | | | 6 | 360° | ON-OFF | 12-24V | 45A | 15A-9A | 15A | 107,9x152,4x88,9 | 0,610 |
| K 29 04 374G | | | 4 | 360° | ON-OFF | 12-24V | 45A | 15A-9A | 15A | 107,9x109,2x88,9 | 0,440 |
| K 29 04 378G | | | 8 | 360° | ON-OFF | 12-24V | 45A | 15A-9A | 15A | 107,9x181,3x88,9 | 0,770 |



Interruttori «Mini Rocker»

Interruttori per pannelli serie 360.
UNIPOLARI

360 Panel «Mini Rocker» switches

Suitable for 360 panels.
SINGLE POLE

| Articolo - Item | €/pc. | Mod. | Funzione-Function | Potenza max Max power 12V DC | Potenza max Max power 24V DC | Potenza max Max power 230V AC | Sezioni terminali Terminal size | kg. |
|-----------------|-------|------|-------------------|---------------------------------|---------------------------------|----------------------------------|------------------------------------|-------|
| K 33 07 480 | | 7480 | ON-OFF | 10A | 10A | 10A | F4,8 | 0,040 |
| K 33 07 481 | | 7481 | (ON)-OFF | 10A | 10A | 6A | F4,8 | 0,040 |
| K 33 07 484 | | 7484 | (ON)-OFF-(ON) | 10A | 8A | 8A | F4,8 | 0,040 |
| K 33 07 485 | | 7485 | (ON)-OFF-(ON) | 10A | 8A | 8A | F4,8 | 0,040 |



K3307480-481



K3307484



K3307485



Caricatori con doppia porta USB

Dotati di doppia porta USB con tappo di protezione per una più lunga durata operativa dei caricatori. Realizzati in materiale anti-corrosione in grado di assicurare contatti affidabili e di ridurre il rischio di cadute di tensione.

Dual USB Chargers

Two USB ports with protective cap. Protective cap with tether keeps dust and spray from shortening the life of the charger. Made with corrosion resistant materials which ensure a solid contact and low voltage drop.

| Articolo - Item | €/pc. | Mod. | Corrente max. uscita Maximum Output Current | Voltaggio d'entrata Input Voltage | Voltaggio d'uscita Output Voltage | Colore-Colour | Descrizione - Description | kg. |
|-----------------|-------|---------|--|--------------------------------------|--------------------------------------|---------------|---|-------|
| K 33 01 016 | | 1016 | 2,1A DC | 12V DC | 5V DC ± 5% | Nero-Black | Pres a con 2 porte USB Dual USB Charger Socket | 0,090 |
| K 33 74 016 | | 1016200 | 2,1A DC | 12V DC | 5V DC ± 5% | Bianco-White | Pres a con 2 porte USB Dual USB Charger Socket | - |
| K 33 01 045 | | 1045 | 4,8A DC | 9-32V DC | 5V DC ± 5% | Nero-Black | Pres a con 2 porte USB Dual USB Charger Socket | 0,070 |



K3301016



K3374016



K3301045

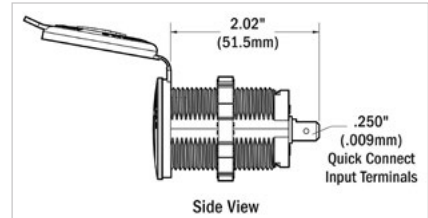

Pannello con presa e doppia porta USB

Pres a DC e caricatore USB in un unico pannello 360.

Socket & Dual USB Charger panels

Integrates DC sockets and USB Charger with 360 Panel system.

| Articolo - Item | €/pc. | Mod. | Descrizione - Description | mm. | kg. |
|-----------------|-------|------|--|----------------|-------|
| K 33 01 478 | | 1478 | Pres a 12V DC + 2 Caricatori USB 12V DC 12V DC Socket + 12V DC Dual USB Charger | 124 x 121 x 38 | 0,320 |



Sistema presa-spina 12 Volts

Materiale resistente alla corrosione per garantire un contatto ottimale e una bassa dispersione. Larga superficie di contatto per un'ottima connessione elettrica. Completa di guarnizione e tappo. Facile installazione.

12 Volt Socket-Plug System

Corrosion resistant materials to ensure solid contact and low voltage drop. Large contact surfaces for good electrical connection. Twist lock system-plug locks securely into socket. Internal strain relief and cord seal. Nickel plated copper alloy used for all current carrying components.

| Articolo - Item | €/pc. | Mod. | Descrizione - Description | Voltaggio nominale Voltage nominal | Amperaggio max. in funzione Amperage Max. Operating | kg. |
|-----------------|-------|---------|---|---------------------------------------|--|-------|
| K 33 01 010 | | 1010 | Spina - Plug | 12V DC | 10A DC | - |
| K 33 01 011 | | 1011 | Pres a nera - Black Socket | 12V DC | 15A DC | - |
| K 33 74 011 | | 1011200 | Pres a bianca - White Socket | 12V DC | 15A DC | - |
| K 33 04 353 | | 4363 | Panel w/12V socket, 15A circuit breaker and a 2,1A Dual USB Charger | - | - | 0,180 |



K3301010



K3301011



K3374011



K3304353

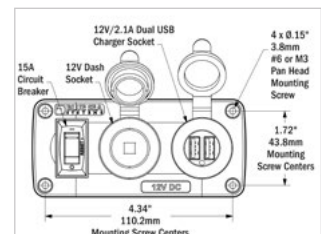
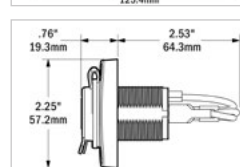
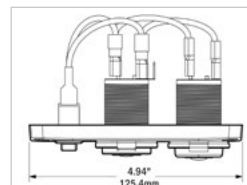

Frontale stagno IP 66.
Display a caratteri Led rossi di grosse dimensioni (14,2 mm).
Lettura con due decimali (es: 12,75V).
Illuminazione display regolabile su 3 livelli.

IP 66 waterproof.
Allows easy monitoring of key AC functions. Large, bright Led characters.
Three levels of brightness. Splash-proof case.
Easy to surface mount in a 2" round hole

Voltmetro CC

Precisione di lettura ± 0,5%.

DC Voltmeter

Accuracy (% of reading): ± 0,5%.

| Articolo - Item | €/pc. | Mod. | Tensione utilizzo Operating current V | Scala lettura Reading scale | Consumo max Max consumption V | Allarme visivo Visual alarm | Allarme sonoro Audio alarm | ↑ mm. | Foro incasso Mounting hole mm. | kg. |
|-----------------|-------|------|--|--------------------------------|----------------------------------|--------------------------------|-------------------------------|----------------|-----------------------------------|-------|
| K 35 08 235 | | 8235 | 7-60 | 0-60 | 1 | No | No | 73,5x61,7x86,3 | 52 | 0,200 |
| K 35 08 251 | | 8251 | 7-60 | 0-60 | 1 | Si-Yes | Si-Yes | 73,5x61,7x86,3 | 52 | 0,510 |



Amperometro CC

Lettura 0,01-99,9A e 100-500A precisione ± 0,5%.
Include shunt 500A/50 mv.

DC Ammeter

Reading 0,01-99,9A and 100-500A Accuracy ± 0,5%.
Includes shunt 500A/50 mv.

| Articolo - Item | €/pc. | Mod. | Tensione utilizzo Operating current V | Scala lettura Reading scale | Consumo max Max consumption V | Allarme visivo Visual alarm | Allarme sonoro Audio alarm | ↑ mm. | Foro incasso Mounting hole mm. | kg. |
|-----------------|-------|------|--|--------------------------------|----------------------------------|--------------------------------|-------------------------------|----------------|-----------------------------------|-------|
| K 35 08 236 | | 8236 | 7-60 | -500 +500 | 1 | No | No | 73,5x61,7x86,3 | 52 | 0,480 |



STRUMENTI ANALOGICI CC | DC ANALOG DIN METERS

Voltmetro analogico CC

Semplice collegamento con soli due fili (al + e al -).
Intercambiabili in tutti i quadri predisposti «BlueSea».
Possibilità di montaggio sia a retroquadro che esterno.

DC Analog voltmeters

Easy connection: 2 wires to + and -.
Can be fitted on the whole «BlueSea» panels range.
Rear panel, external panel mounting options.



Misura «Standard»

«Standard» size

| Articolo - Item | €/pc. | Mod. | Scala lettura CC | | Precisione Accuracy | Lett increm ago Needle reading | ↑ mm. | Montaggio-Fitting | | kg. |
|-----------------|-------|------|------------------|---------------------------|------------------------|-----------------------------------|-----------|-------------------|---------------------|-------|
| | | | DC Reading scale | Impianti CC DC Systems | | | | Est. mm. | Retro quadro mm. | |
| K 36 08 003 | | 8003 | 8-16V | 12V | 2,50% | 0,25V | 71,1x60,3 | 51 | 66,6x32 | 0,110 |
| K 36 08 240 | | 8240 | 18-32V | 24V | 2,50% | 0,25V | 71,1x60,3 | 51 | 66,6x32 | 0,110 |



Amperometri CC

Semplice collegamento con soli due fili (dallo Shunt esterno).
Intercambiabili in tutti i quadri predisposti «BlueSea» (montaggio a retroquadro). Shunt esterno dedicato incluso da 50mV. Possibilità di montaggio sia a retroquadro che esterno. Precisione 2,5%.

DC Analog ammeters

Easy connection with 2 wires (from the outer Shunt).
Can be fitted on the whole «BlueSea» panels range.
Rear panel, external panel mounting options.
Accuracy: 2,5%.



Misura «Standard»

«Standard» size

| Articolo - Item | €/pc. | Mod. | Scala lettura CC | | Shunt int Inner Shunt | Shunt est Outer Shunt | Lett increm ago Needle reading | ↑ mm. | Montaggio-Fitting | | kg. |
|-----------------|-------|------|------------------|---------------------------|--------------------------|--------------------------|-----------------------------------|-----------|-------------------|---------------------|-------|
| | | | DC Reading scale | Impianti CC DC Systems | | | | | Est. mm. | Retro quadro mm. | |
| K 36 08 005 | | 8005 | 0-25A | 12V | Si-Yes | No | 1A | 71,1x60,3 | 51 | 66,6x32 | 0,110 |
| K 36 08 022 | | 8022 | 0-50A | 24V | No | 50A/50mV | 2A | 71,1x60,3 | 51 | 66,6x32 | 0,270 |
| K 36 08 017 | | 8017 | 0-100A | 24V | No | 100A/50mV | 4A | 71,1x60,3 | 51 | 66,6x32 | 0,270 |



Amperometro analogico con zero centrale

Semplice collegamento con soli due fili (dallo Shunt esterno).
Shunt esterno dedicato incluso da 50 mV.

Zero center analog ammeters

Connection: 2 wire from shunt , 3 connections for backlight.

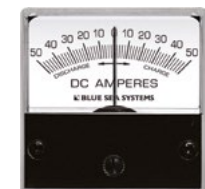

Misura «Standard»

«Standard» size

| Articolo - Item | €/pc. | Mod. | Scala lettura CC | | Shunt int Inner Shunt | Shunt est Outer Shunt | Lett increm ago Needle reading | ↑ mm. | Montaggio-Fitting | | kg. |
|-----------------|-------|------|------------------|---------------------------|--------------------------|--------------------------|-----------------------------------|-----------|-------------------|---------------------|-------|
| | | | DC Reading scale | Impianti CC DC Systems | | | | | Est. mm. | Retro quadro mm. | |
| K 36 08 254 | | 8254 | 50A-50mV | 24V | No | 50A/50mV | 2A | 50,8x50,8 | 44 | 47,2x26,8 | 0,180 |



Shunt per amperometri CC

Selezionati per la perfetta compatibilità con gli strumenti «Blue Sea».
Uso continuo: Si consiglia di non superare il 66% della capacità max - Uso intermittente: 5 min on 5 off 100% della capacità max - Picco max: per 3 secondi 300% della capacità max.

DC Shunts

For use with DC Ammeters. For continuous operation, it is recommended that shunts not be run at more than two-thirds (66%) the rated current under normal conditions. I300 Amperage Int. Rating (5 min.) 100%—Full scale rating. I3 Amperage Int. Rating (3 sec.) 300%—Full scale rating



| Articolo - Item | €/pc. | Mod. | Fondoscala amp dig Dig Amp reading | Lett sul negativo Negative reading | Bulloni potenza Power bolts mm. | Viti Screws | Uscita Shunt Shunt | ↑ mm. | kg. |
|-----------------|-------|-------|---------------------------------------|---------------------------------------|------------------------------------|----------------|-----------------------|----------------|-------|
| K 36 09 230 | | 9230B | 0-100A | Si-Yes | 6 | 4 | 50mV | 50,8x31,7x42,6 | 0,090 |



Frontale stagno IP 66.
Possibilità di montaggio sia a retroquadro che esterno.
Display a caratteri Led rossi di grosse dimensioni (14,2 mm).
Illuminazione display regolabile su 3 livelli.

IP 66 waterproof.
Allows easy monitoring of key AC functions. Large, bright Led characters.
Three levels of brightness. Splash-proof case.
Easy to surface mount in a 2" round hole

Voltmetro CA

AC Voltmeter

Precisione di lettura ± 1%.

Accuracy (% of reading): ± 1%.

| Articolo - Item | €/pc. | Mod. | Tensione utilizzo Operating current V | Scala lettura Reading scale | Consumo max Max consumption V | Allarme visivo Visual alarm | Allarme sonoro Audio alarm | ↳ mm. | Foro incasso Mounting hole mm. | kg. |
|-----------------|-------|------|--|--------------------------------|----------------------------------|--------------------------------|-------------------------------|-----------------|-----------------------------------|-------|
| K 37 08 237 | | 8237 | 80-249 | 80-249 | 1 | No | No | 73,5x61,7x85,73 | 52 | 0,330 |



Multimetro CA con allarme

AC Multimeter with Alarm

Precisione di lettura ± 1%. Lettura Corrente: (0 - 150A).
Lettura Tensione: (80 - 270V). Lettura Kilowatts: (10 - 45Kw).
Lettura Hertz: (40 - 90Hz).

Accuracy (% of reading): ± 1%. Current measurement: (0 - 150A).
Voltage measurement: (80 - 270V). Power measurement: (10 - 45Kw). L.Frequency measurement: (40 - 90Hz).

| Articolo - Item | €/pc. | Mod. | Tensione utilizzo Operating current V | Scala lettura Reading scale | Consumo max Max consumption V | Allarme visivo Visual alarm | Allarme sonoro Audio alarm | ↳ mm. | Foro incasso Mounting hole mm. | kg. |
|-----------------|-------|------|--|--------------------------------|----------------------------------|--------------------------------|-------------------------------|----------------|-----------------------------------|-------|
| K 37 08 247 | | 8247 | 80-270 | V-A-Hz-W | 0,027 | Si-Yes | Si-Yes | 73,5x61,7x86,3 | 52 | 0,330 |



STRUMENTI ANALOGICI CA | AC ANALOG DIN METERS

Voltmetri analogici CA

AC Analog voltmeters

Semplice collegamento con soli due fili (alla fase e al neutro).
Immediata percezione visiva. Intercambiabili in tutti i quadri predisposti «Blue Sea» (montaggio a retroquadro). Possibilità di montaggio sia a retroquadro che esterno. Precisione: 2,5%.

Connection: 2 wire to AC hot and neutral, 3 connections for backlight. Backlit meter face (separate 12V or 24V DC backlight connections). Rear panel, external panel mounting options. Accuracy: 2,5%.

Misura «Standard»

«Standard» size

| Articolo - Item | €/pc. | Mod. | Scala lettura CC DC Reading scale | Impianti CA AC Systems | Lett. increm. ago Needle reading | ↳ mm. | Montaggio-Fitting | | kg. |
|-----------------|-------|------|--------------------------------------|---------------------------|-------------------------------------|-----------|-------------------|------------------|-------|
| | | | | | | | Est. mm. | Retro quadro mm. | |
| K 38 09 354 | | 9354 | 0-250V | 230V | 5A | 71,1x60,3 | 51 | 66,6x32 | 0,120 |



Amperometri CA

AC Ammeters

Trasformatore toroidale per la lettura amperometrica incluso.
Semplice collegamento con soli due fili (dal trasformatore CA esterno).
Immediata percezione visiva. Intercambiabili in tutti i quadri predisposti «Blue Sea» (montaggio a retroquadro). Possibilità di montaggio sia a retroquadro che esterno. Precisione: 2,5%.

Includes appropriate external AC Current Transformer.
Connection: 2 wire to AC hot and neutral, 3 connections for backlight. Backlit meter face (separate 12V or 24V DC backlight connections). Rear panel, external panel mounting options. Accuracy: 2,5%.

Misura «Standard»

«Standard» size

| Articolo - Item | €/pc. | Mod. | Scala lettura CC DC Reading scale | Trasform lettura amperometro Current transformer | Lett increm ago Needle reading | ↳ mm. | Montaggio-Fitting | | kg. |
|-----------------|-------|------|--------------------------------------|--|-----------------------------------|-----------|-------------------|------------------|-------|
| | | | | | | | Est. mm. | Retro quadro mm. | |
| K 38 08 258 | | 8258 | 0-100A | Si-Yes | 4A | 71,1x60,3 | 51 | 66,6x32 | 0,160 |



Trasformatore per correnti alternate

AC Transformer

Da utilizzarsi per letture amperometriche in alternata.

For use with AC Ammeters.

| Articolo - Item | €/pc. | Mod. | Fondoscala amp dig Ratio | Uscita trasform Output AC | Lettura sulla fase Reading | Ø est trasform Outer Ø | Ø int pass cavi Inside Ø | Tipo Type | kg. |
|-----------------|-------|------|-----------------------------|------------------------------|----------------------------------|---------------------------|-----------------------------|--------------|-----|
| | | | | | | | | | |

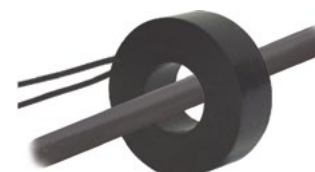

STRUMENTI ANALOGICI | ANALOG DIN METERS

Strumenti analogici DIN per corrente continua DC Analog Din Meter

| Articolo - Item | €/pc. | Mod. | Tipo Type | Tensione utilizzo Operating current V | Scala lettura Reading scale | Shunt interno Internal shunt | Shunt esterno Ext shunt | ↳ mm. | Foro incasso Mounting hole mm. | kg. |
|-----------------|-------|------|--------------|--|--------------------------------|---------------------------------|----------------------------|-------|-----------------------------------|-----|
| | | | | | | | | | | |



VISIT OUR B2B AREA

CREATE A CUSTOMER ACCOUNT

CHECK AVAILABILITY & QUANTITY OF ITEMS

CHECK YOUR COMMERCIAL CONDITION

PLACE YOUR ORDER

TRACK YOUR ORDER STATUS

TRACK YOUR PAYMENT PROCESS

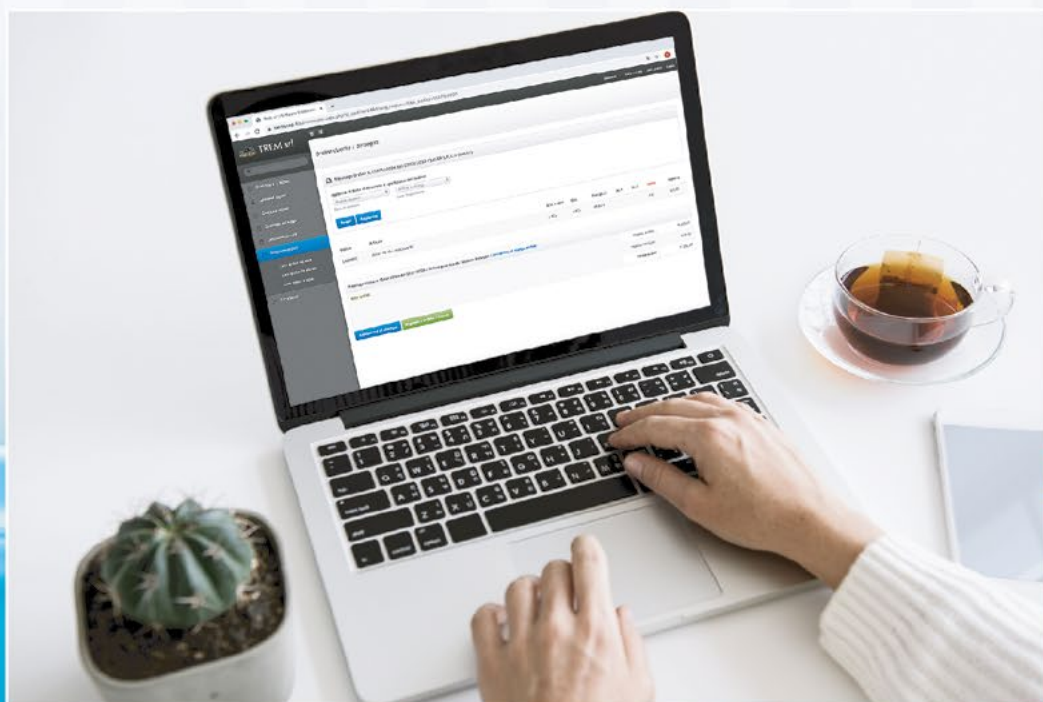

WWW.TREM.NET



BATTERIE E CASSETTE PORTABATTERIA | BATTERIES ACCESSORIES

Batterie a tecnologia AGM

Le batterie TR.EM. con tecnologia AGM sono sigillate, pertanto esenti da esalazioni acide. Estremamente compatte, hanno prestazioni elevate, nonostante misure e pesi più contenuti rispetto alle batterie convenzionali. Sono prive di manutenzione e hanno una lunga durata, oltre a una bassissima auto-scarica. Prodotto ideale batterie/servizi. Possono funzionare in qualsiasi posizione.

AGM Technology Battery

When it's simply not possible or practical to plug into the main supply, the AGM technology provides the perfect mobile power source. This latest development offers major benefits over other batteries and can be used in marine and caravanning applications. Significantly improved lifespan.

| Articolo - Item | €/pc. | Volts | Capacità - Capacity Ah | | Scarica A. Rapida (EN) | Lunghezza Length mm. | Profondità Width mm. | Altezza Height mm. | Terminali Terminals | Kg. |
|-----------------|-------|-------|------------------------|-----|------------------------|----------------------|----------------------|--------------------|---------------------|--------|
| | | | 20h | 10h | | | | | | |
| L 15 10 179 | | 12 | 100 | 74 | 66 | 600 | 350 | 167 | F11* | 24,500 |
| L 15 00 220 | | 12 | 120 | 115 | 92 | 800 | 330 | 171 | F12 | 32,000 |
| L 15 12 287 | | 12 | 140 | 130 | 119 | 950 | 341 | 172 | F12 | 42,500 |
| L 15 12 240 | | 12 | 200 | 190 | 180 | 1150 | 522 | 218 | F12 | 58,000 |



Caratteristiche tecniche principali - Main features

| | |
|--|---|
| Ermetica Hermetic | Priva di esalazioni e fuoriuscita acido Esente da manutenzione (NON APRIRE!) Inclinazione max. 90° No fumes and leakage of acid No maintenance required (DO NOT OPEN!) Maximum inclination 90° |
| Temperatura Temperature | Capacità dichiarata 25°C +/- 3°C Range lavoro da -25°C ~ 55°C Rated capacity 25°C +/- 3°C Working range from -25°C to 55°C |
| Tecnologia di costruzione Building technology | Piastre in lega piombo/acciaio Separatore in fibre di vetro Contenitore in ABS (UL 94-HB) Plates in lead alloy and steel Separator in fibreglass Case in ABS (UL 94-HB) |



Terminali Batterie

Battery Terminals

| Articolo - Item | €/pair | Terminale-Terminal mod. | M | Ø mm. |
|-----------------|--------|-------------------------|---|-------|
| L 15 00 020 | | F11 | 6 | 14 |
| L 15 00 025 | | F12 | 8 | 16 |



Doppia piastra fissa batteria o serbatoio

- Kit completo di:
- Cinghia da 135 cm
 - Fibbia regolabile
 - 2 Piastre in plastica
 - 2 Ponticelli
 - 8 Viti 3,9x16 mm

Double plate for battery box and portable tank

- Set complete with:
- Belt 135 cm
 - Adjustable buckle
 - 2 Plastic plates
 - 2 Fittings
 - 8 Screws 3,9x16 mm

| Articolo - Item | €/kit | Fabbricata in-Manufactured in | kg. |
|-----------------|-------|-------------------------------|-------|
| N 01 00 180 | | Plastica-Plastic | 0,190 |

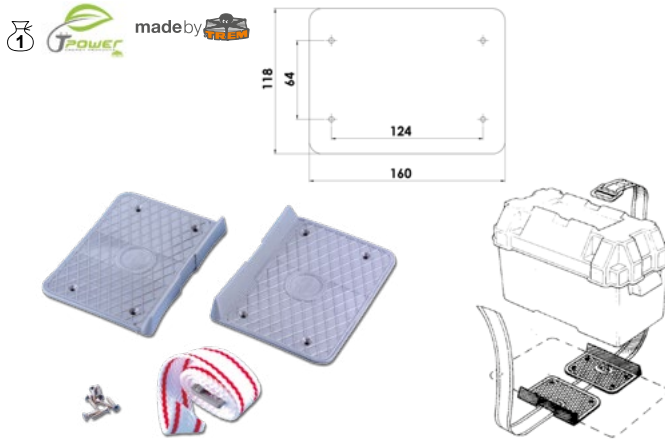

Vassoio portabatteria o serbatoio

Fabbricato in gomma nera. Assolve a funzioni antiderapanti di ammortizzamento della batteria e di raccolta di eventuale fuoriuscita di acido.

Single plate for battery box and portable tank

Manufactured in black rubber. Useful as protection against fuel and acid leakage.

| Articolo - Item | €/pc. | Per batterie For batteries | Per serbatoi For tanks | mm. | kg. |
|-----------------|-------|----------------------------|------------------------|---------|-------|
| N 01 38 380 | | <140AH | <12LT | 380x250 | 0,380 |
| N 01 47 550 | | <200AH | <24LT | 470x320 | 0,550 |



Cinghia fermaserbatoio o batteria

Cinghia completa di fibbie di regolazione e di due ponticelli da applicare sul fondo dell'imbarcazione. Con viti autofilettanti.

Fastening belt for battery box or auxiliary jerrycan

Belt complete with adjusting buckle. Supplied with self-threading screws.

| Articolo - Item | €/Kit. | Lunghezza cinghia Belt length mm. | kg. |
|-----------------|--------|-----------------------------------|-------|
| N 01 40 000 | | 1350 | 0,030 |



«Battery Tester»

Realizzato in ABS. Bassa: 5-11,7V. (12V.) - 16-23,5V. (24V.) Media: 11,8-12,47V. (12V.) - 23,6-24,9V. (24V.) Alta: 12,5-15,9V. (12V.) - 25-30V. (24V.)

«Battery Tester»

Manufactured in ABS. Low: 5-11,7V. (12V.) - 16-23,5V. (24V.) Medium: 11,8-12,47V. (12V.) - 23,6-24,9V. (24V.) High: 12,5-15,9V. (12V.) - 25-30V. (24V.)

| Articolo - Item | €/pc. | Mod. | kg. |
|-----------------|-------|---|-------|
| L 15 01 341 | | con presa accendisigari-cigarette lighter | 0,080 |



Coppia morsetti per batteria serie «Extra» positivo e negativo

Fabbricati in ottone.

Pair of battery clamps series «Extra» positive and negative

Manufactured in brass.

| Articolo - Item | €/pairs | Materiale-Material | kg. |
|-----------------|---------|----------------------------------|-------|
| L 20 06 000 | | Acciaio zincato-Galvanised steel | 0,150 |
| L 20 06 857 | | Ottone-Brass | 0,250 |



Morsetto stacca batterie «ON-OFF» modello antifurto

Con una rotazione del pomello si inserisce il contatto elettrico sul polo+. Rimuovendo il pomello si ottiene una efficace azione antifurto.

«ON-OFF» Circuit breaker, antitheft model

Just rotate the knob to disconnect the electric contact on pole +. By removing the knob a good antitheft action can be performed.

| Articolo - Item | €/pc. | kg. |
|-----------------|-------|-------|
| L 20 03 007 | | 0,140 |

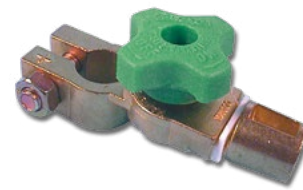

Cassetta portabatteria «Octopus»

Con cinghie e ponticelli di fissaggio.

Battery-holder «Octopus»

Complete with belts and fastening fittings.

| Articolo - Item | €/pc. | Fabbricata in Manufactured in | Per batterie For batteries max A-h | Dimensioni-Size mm. | | Nastro di ricambio Spare belt |
|-----------------|-------|---|---------------------------------------|---------------------|---------------|----------------------------------|
| | | | | Interne-Inner | Esterne-Outer | |
| N 01 38 120 | | Moplen bianco/rosso White/Red Moplen | 90 | 285x190xH240 | 320x230xH270 | N0140000 |



SUGGESTED ITEM



Art. N0100180
(pag. 224)

COMPLETO DI-COMLETE WITH



Art. N0140000
(pag. 224)



Cassetta portabatteria «Kanguro»

Con cinghie, ponticelli e pannello separatore.

Battery-holder «Kanguro»

Complete with belts and fastening fittings.

| Articolo - Item | €/pc. | Fabbricata in Manufactured in | Per batterie For batteries max A-h | Dimensioni-Size mm. | | Nastro di ricambio Spare belt |
|-----------------|-------|---|---------------------------------------|---------------------|---------------|----------------------------------|
| | | | | Interne-Inner | Esterne-Outer | |
| N 01 41 250 | | Moplen bianco/giallo White/Yellow Moplen | 140 | 410x200xH250 | 460x240xH280 | N0140000 |



SUGGESTED ITEM



Art. N0100180
(pag. 224)

COMPLETO DI-COMLETE WITH



Art. N0140000
(pag. 224)



Cassetta portabatteria «Koala»

Con cinghie e ponticelli di fissaggio.

Battery-holder «Koala»

Complete with belts and fastening fittings.

| Articolo - Item | €/pc. | Fabbricata in Manufactured in | Per batterie For batteries max A-h | Dimensioni-Size mm. | | Nastro di ricambio Spare belt |
|-----------------|-------|--|---------------------------------------|---------------------|---------------|----------------------------------|
| | | | | Interne-Inner | Esterne-Outer | |
| N 01 43 260 | | Polipropilene nero Black Polypropylen | 110 | 360x180xH240 | 430x230xH270 | N0140000 |



SUGGESTED ITEM



Art. N0100180
(pag. 224)

COMPLETO DI-COMLETE WITH

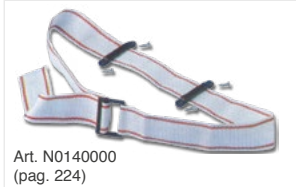

Art. N0140000
(pag. 224)



Cassetta portabatteria «Combi»

Con cinghie e ponticelli di fissaggio.

Battery-holder «Combi»

Complete with belts and fastening fittings.

| Articolo - Item | €/pc. | Fabbricata in Manufactured in | Per batterie For batteries max A-h | Dimensioni-Size mm. | |
|-----------------|-------|---|---------------------------------------|---------------------|---------------|
| | | | | Interne-Inner | Esterne-Outer |
| N 01 14 546 | | Polipropilene bianco/blu White/Blue Polypropylen | 100 | 340x200xH270 | 350x210xH280 |



SUGGESTED ITEM



Art. N0100180
(pag. 224)



Cassetta portabatteria precablata ed equipaggiata

Equipaggiata con morsetti esterni + presa corrente stagna con fusibile automatico da 10A stagno + indicatore a LED dello stato di carica della batteria.

Pre-wired and equipped battery-holder

Equipped with external clamps + watertight socket with automatic fuse 10A + LED indicator of battery charge level.

| Articolo - Item | €/pc. | Per-For | Fabbricata in Manufactured in | Per batterie For batteries max A-h | Dimensioni-Size mm. | |
|-----------------|-------|-----------------------|----------------------------------|---------------------------------------|---------------------|---------------|
| | | | | | Interne-Inner | Esterne-outer |
| N 01 11 537 | | 1 Batteria-Battery | Polipropilene Polypropylen | 105 | 318x175xH257 | 421x245xH309 |





A

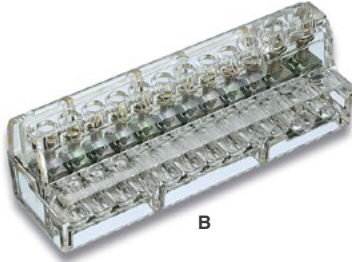

B

Morsettiere unipolari

Morsettiere di collegamento e derivazione a 3, 5, 6 e 10 vie per conduttori da 1 a 6 mmq. Compatte e robuste, ideali per l'esecuzione rapida e sicura di impianti elettrici. I morsetti a serraggio indiretto garantiscono un'ottima stabilità nel tempo della connessione ed hanno l'estremità inferiore opportunamente sagomata per chiudere gli ingressi eventualmente non utilizzati. Corpo in policarbonato antiurto e antistinguente, morsetti in acciaio trattato, piastrina di collegamento in rame. 450V.

Single pole terminal blocks

3, 5, 6 and 10 way, single pole terminal blocks for conductor section 17 to 10 AWG. Self contained and robust, they are quick and easy to install for both industrial and domestic use. The indirect clamping of the "ZETApiù" terminal blocks guarantees a low and stable contact resistance. Indirect clamping eliminates damage to the conductor strands. The easy-entry receptacles also grant a fast and reliable insertion of the cable. Polycarbonate body, clamps in electroplated galvanized steel and connection plate in tinned electrolytic copper electrolytically. 450V.

MOD. A

| Articolo - Item | €/pc. | Mod. | Sezione cavo Cable section mm ² | ↑ mm. | N. Vie Ways | | |
|-----------------|-------|-------|---|------------|----------------|---|--|
| L 15 05 006 | | Z6-5D | 6 | 35x40x36,5 | 5 | 1 | |
| L 15 06 006 | | Z6-6D | 6 | 23x53x34 | 6 | 1 | |

MOD. B

| Articolo - Item | €/pc. | Mod. | Sezione cavo Cable section mm ² | ↑ mm. | N. Vie Ways | | |
|-----------------|-------|--------|---|----------|----------------|---|--|
| L 15 03 160 | | Z16-3D | 16 | 38x50x44 | 3 | 1 | |



Morsetti unipolari

Morsetti di collegamento e derivazione per conduttori da 0,5 a 35mmq. Corpo in policarbonato antiurto antistinguente, morsetto e vite in acciaio trattato zincati elettroliticamente. Piastrina di collegamento in rame.

Single pole terminal blocks

One way, single pole terminal blocks for conductors sections from 0,5 - 35 mm². Polycarbonate body, clamps in electroplated galvanized steel and connection plate in tinned electrolytic copper electrolytically.

| Articolo - Item | €/pc. | €/box | Mod. | Sezione cavo Cable section mm ² | ↑ mm. | | |
|-----------------|-------|-------|--------|---|--------------------|----|--|
| L 15 01 025 | | | Z2,5-1 | 2,5 | 7,6 x 20 x 23,5 | 10 | |
| L 15 01 060 | | | Z6-1 | 6 | 11,5 x 28 x 29 | 10 | |
| L 15 01 101 | | | Z10-1 | 10 | 15,6 x 32 x 32,5 | 10 | |
| L 15 01 160 | | | Z16-1 | 16 | 18 x 34 x 38 | 10 | |
| L 15 01 250 | | | Z25-1 | 25 | 20,8 x 42,5 x 43,5 | 10 | |



Piggy-Back faston doppio preisolato da 6,3 mm

Pre insulated Piggy-Back double faston 6,3 mm

| Articolo - Item | €/box | Cavo mm ² | Faston abbinabili Compatible Faston | |
|-----------------|-------|----------------------|--|-----|
| L 15 68 256 | | 1,5/2,5 | L1568225-L1568025 | 100 |
| L 15 68 156 | | 0,25/1,5 | L1568125 | 100 |



Terminali preisolati cilindrici

Cylindrical pre insulated terminals

| Articolo - Item | €/box | Mod. | I-Cavo mm ² | E Ø mm. | |
|-----------------|-------|-------------------|------------------------|---------|-----|
| L 15 05 250 | | Maschio Male | 1/2,5 | 4 | 100 |
| L 15 05 251 | | Femmina Female | 1/2,5 | 4 | 100 |

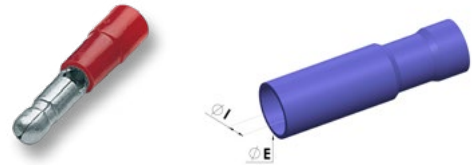

Spinotto maschio + giunzione femmina preisolato

Male plug + pre insulated female connection

| Articolo - Item | €/box | Mod. | Cavo mm ² | |
|-----------------|-------|--------------|----------------------|-----|
| L 15 67 268 | | Maschio-Male | 2,5/6,0 | 100 |

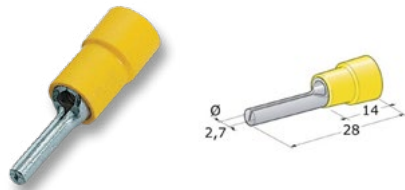

Tubetto preisolato termoretraibile 2 cavi per giunzione stagna

Pre-insulated heat-shrinkable pipe for sealing joints

| Articolo - Item | €/box | I-Cavo mm ² | |
|-----------------|-------|------------------------|-----|
| L 15 23 036 | | 1/2,5 | 100 |
| L 15 34 041 | | 2,5/6,0 | 100 |



Faston preisolati da 6,3 mm

Pre insulated Faston 6,3 mm

| Articolo - Item | €/box | Mod. | Cavo mm ² | Apertura Opening mm. | |
|-----------------|-------|----------------|----------------------|-------------------------|-----|
| L 15 68 025 | | Femmina-Female | 1/2,5 | 6,3 | 100 |
| L 15 68 125 | | Maschio-Male | 1/2,5 | 6,3 | 100 |
| L 15 68 060 | | Femmina-Female | 2,5/6,0 | 6,3 | 100 |
| L 15 68 160 | | Maschio-Male | 2,5/6,0 | 6,3 | 100 |



Faston completamente preisolato da 6,3 mm

Fully pre insulated Faston 6,3 mm

| Articolo - Item | €/box | Mod. | Cavo mm ² | Apertura Opening mm. | |
|-----------------|-------|----------------|----------------------|-------------------------|-----|
| L 15 68 225 | | Femmina-Female | 1/2,5 | 6,3 | 100 |
| L 15 68 260 | | Femmina-Female | 2,5/6,0 | 6,3 | 100 |



Cavo batterie flessibili H07V-K

Tensione nominale 100V. Trefoli in rame sottilissimi per la massima flessibilità. Guaina esterna in neoprene siliconico (impermeabilità al salino). Direttiva europea 2006/95/CE

Flexible battery cable H07V-K

Nominal voltage rating 100V. Copper leaves for a higher flexibility. Outer sheath manufactured in Neoprene. European directive 2006/95/CE

| Articolo - Item | €/mt. | € | N. conduttori Threads N. | Sezione cavo Cable section mm ² | Ø esterno outer mm. | Colore guaina Sheath colour | Spessore isolante Insulating thickness mm. | Resistance 20°C Ohm/Km. | Portata-Load 30°C A | mt. | kg. |
|-----------------|-------|---|-----------------------------|--|------------------------|--------------------------------|--|----------------------------|------------------------|-----|--------|
| L 15 80 016 | | | 1x | 16 | 8 | Nero-Black | 1,6 | 1,21 | 76 | 25 | 4,200 |
| L 15 82 016 | | | 1x | 16 | 8 | Rosso-Red | 1,6 | 1,21 | 76 | 25 | 4,200 |
| L 15 80 025 | | | 1x | 25 | 10 | Nero-Black | 1,8 | 0,78 | 101 | 25 | 6,500 |
| L 15 82 025 | | | 1x | 25 | 10 | Rosso-Red | 1,8 | 0,78 | 101 | 25 | 6,500 |
| L 15 80 035 | | | 1x | 35 | 12 | Nero-Black | 1,8 | 0,55 | 125 | 25 | 8,500 |
| L 15 82 035 | | | 1x | 35 | 12 | Rosso-Red | 1,8 | 0,55 | 125 | 25 | 8,500 |
| L 15 80 050 | | | 1x | 50 | 14 | Nero-Black | 1,8 | 0,38 | 151 | 25 | 12,500 |
| L 15 82 050 | | | 1x | 50 | 14 | Rosso-Red | 2,2 | 0,38 | 151 | 25 | 12,500 |
| L 15 80 070 | | | 1x | 70 | 16 | Nero-Black | 2,2 | 0,27 | 192 | 25 | 16,800 |
| L 15 82 070 | | | 1x | 70 | 16 | Rosso-Red | 2,2 | 0,27 | 192 | 25 | 16,800 |



Guaine termorestringenti termoblock

Autoestinguenti in Poliolefina rapporto di restringimento 2 : 1
Caratteristiche generali:
• Temperatura di utilizzo: -55°C +125°C
• Temperatura minima di restringimento: 70°C
• Temperatura di restringimento completo: 110°C
• Conforme a RoHS

Termoblock heat-shrinkable tubing

Heat-shrinkable in polyolefin. Contracting ratio 2:1
General features:
• Operating temperature: -55°C +125°C
• Minimum shrink temperature: 70°C
• Minimum fully recovery temperature: 110°C
• RoHS compliant

| Articolo - Item | € | Ø interno espanso Expanded inner Ø mm. | Ø interno ristretto Narrow inner Ø mm. | Colore-Colour | mt. | kg. |
|-----------------|---|---|---|---------------|-----|-----|
| L 15 05 095 | | 10 | 5 | Nero-Black | 10 | |
| L 15 12 254 | | 25 | 12 | Nero-Black | 5 | |

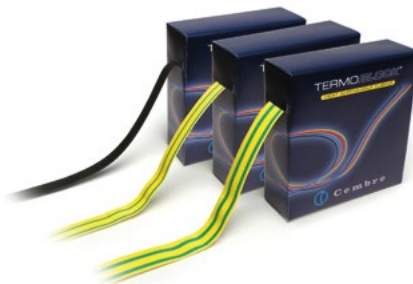

Capicorda di potenza in rame stagnato

Tin-plated copper lugs

| Articolo - Item | € sacchetto da 10 pz. | Sezione cavo Cable section mm ² | D3 mm. | L mm. | D4 mm. | D2 mm. | D1 mm. |
|-----------------|-----------------------|---|--------|-------|--------|--------|--------|
| L 15 06 016 | | 16 | 14 | 35 | 6,4 | 5,6 | 7,5 |
| L 15 08 025 | | 25 | 16 | 40 | 8,3 | 7,1 | 9,5 |
| L 15 08 035 | | 35 | 19 | 44 | 8,3 | 8,2 | 11 |
| L 15 10 035 | | 35 | 19 | 44 | 10,3 | 8,2 | 11 |
| L 15 08 050 | | 50 | 20 | 53 | 8,3 | 9,5 | 13 |
| L 15 10 050 | | 50 | 20 | 53 | 10,3 | 9,5 | 13 |
| L 15 10 070 | | 70 | 22 | 57 | 10,5 | 11,2 | 14,2 |
| L 15 13 070 | | 70 | 22 | 57 | 13,2 | 11,2 | 14,2 |

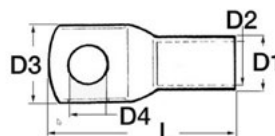



Staccabatteria Mini con pomello

Capacità 250A in continuo a 12V; 350A intermittente. Montaggio a scomparsa.

Mini Battery Switch with Knob

Rated 250A Continuous Duty at 12V; 350A Intermittent. Flush Mount.

| Articolo - Item | €/pc. | Capacità Capacity | Spunto max | Posizione Position | Angolo apert. pomello Knob opening angle | kg. |
|-----------------|-------|-------------------|------------|--------------------|--|-------|
| L 06 01 392 | | 250A | 350A | 2P | 90° | 0,190 |

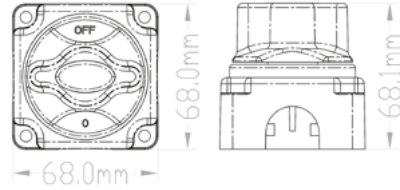

Deviatore staccabatteria Mini

Deviatore staccabatteria compatto a quattro posizioni. Permette di staccare il circuito, di selezionare una delle due batterie, oppure entrambe in contemporanea. Si monta esterno o a incasso.

Mini Battery Switch

Four position battery switch: OFF, battery one, battery two, both batteries. Flush or recessed mounting.

| Articolo - Item | €/pc. | Capacità Capacity | Spunto max | mm. |
|-----------------|-------|-------------------|------------|-----------|
| L 06 10 192 | | 200A | 300A | 70x70xH85 |



Staccabatteria a manopola

Staccabatteria 250A montaggio a parete. Comando a manopola.

Knob battery switch

Wall mounting, 250A.

| Articolo - Item | €/pc. | Capacità Capacity | Spunto max | mm. |
|-----------------|-------|-------------------|------------|-----------|
| L 06 00 092 | | 200A | 350A | 68x68xH66 |



Staccabatteria

Staccabatteria 250A montaggio a parete. Chiave estraibile.

Battery switch

Wall mounting, 250A. With extractable key.

| Articolo - Item | €/pc. | Capacità Capacity | Spunto max | mm. |
|-----------------|-------|-------------------|------------|-----------|
| L 06 00 093 | | 250A | 350A | 68x68xH75 |



COMPLETO DI-COMLETE WITH



Art. L0613066 (pag. 230)



Deviatore staccabatteria

Deviatore staccabatteria per uso continuato a quattro posizioni. Permette di staccare il circuito, di selezionare una delle due batterie, oppure entrambe in contemporanea.

Battery Switch

Four position battery switch: OFF, battery one, battery two, both batteries. Flush or recessed mounting.

| Articolo - Item | €/pc. | Capacità Capacity | Spunto max | mm. |
|-----------------|-------|-------------------|------------|-------------|
| L 06 12 350 | | 280A | 380A | 100x100xH75 |



Stacca batteria Heavy Duty

Capacità 180A in continuo a 12V; 1000A intermittente per 5 sec.

Heavy Duty Battery Switch

Rated 180A Continuous Duty At 12V; 1000A Intermittent/5 sec.

| Articolo - Item | €/pc. | Posizione Position | kg. |
|-----------------|-------|--------------------|-------|
| L 06 10 090 | | 2P (ON-OFF) | 0,250 |



Staccabatteria marino

In policarbonato nero con fissaggio su flangia. Completo di cappuccio stagno in gomma e chiave antispruzzo. Modello con perno chiave in ottone nichelato, robustissimo. Omologato CE. Dispositivo obbligatorio da montare sul cavo positivo, norme ISO 10133.

Marine Battery Switch

Made of black polycarbonate, flange fixing; fitted with watertight rubber cap and splash-proof key. Model with nickel plated brass key pin, very sturdy. Mandatory for mounting on a positive cable, under ISO 10133 standards.

| Articolo - Item | €/pc. | Capacità-Capacity max | | Incasso Flush Ø mm. | Flangia Flange Ø mm. | Chiave di ricambio Spare key | Perni Pins mm. |
|-----------------|-------|-----------------------|-------------|------------------------|-------------------------|---------------------------------|-------------------|
| | | per 5 sec | in continuo | | | | |
| L 06 13 065 | | 1000A | 100A | 57 | 60 | L0613066 | 10 |



COMPLETO DI-COMLETE WITH



Art. L0613066 (pag. 230)



Staccabatteria marino Heavy Duty

In policarbonato nero, con fissaggio su flangia. Completo di coperchio stagno in PVC e chiave anti-spruzzo in ottone nichelato. Omologato CE. Dispositivo obbligatorio da montare sul cavo positivo, norme ISO 10133.

Heavy Duty Marine Battery Switch

Made of black polycarbonate, flange fixing; fitted with watertight rubber cap and nickel-plated splash-proof key. Mandatory for mounting on a positive cable, under ISO 10133 standards.

| Articolo - Item | €/pc. | Capacità-Capacity max | | Incasso Flush Ø mm. | Flangia Flange Ø mm. | Chiave di ricambio Spare key | Perni Pins mm. |
|-----------------|-------|-----------------------|-------------|------------------------|-------------------------|---------------------------------|-------------------|
| | | per 5 sec | in continuo | | | | |
| L 06 10 180 | | 2500A | 280A | 55 | 66 | L0610089 | 10 |



COMPLETO DI-COMLETE WITH



Art. L0610089 (pag. 230)



Staccabatteria con corpo inox

Staccabatteria in policarbonato nero con fissaggio su flangia. Versione extra con corpo in acciaio inox AISI 316. Fissaggio del collo tramite doppio dado filettato. Robustissimo. Completo di coperchio stagno in PVC e chiave antispruzzo in ottone nichelato. Omologato CE. Dispositivo obbligatorio da montare sul cavo positivo, norme ISO 10133.

Battery Switch stainless steel body

Made of black polycarbonate, flange fixing; extra version with AISI 316 stainless steel body, collar mounting with double threaded screw nut, very sturdy; equipped with watertight PVC cap and splash-proof nickel-plated brass key. Mandatory for mounting on a positive cable, under ISO 10133 standards.

| Articolo - Item | €/pc. | Capacità-Capacity max | | Incasso Flush Ø mm. | Flangia Flange Ø mm. | Chiave di ricambio Spare key | Perni Pins mm. |
|-----------------|-------|-----------------------|-------------|------------------------|-------------------------|---------------------------------|-------------------|
| | | per 5 sec | in continuo | | | | |
| L 06 20 180 | | 2500A | 280A | 55 | 66 | L0610089 | 10 |



COMPLETO DI-COMLETE WITH



Art. L0610089 (pag. 230)



Contenitore in ABS completo di interruttore staccabatteria 180A.

Applicabile in parete con scasso Ø 70 mm. Completo di staccabatteria e L0610180.

ABS case with battery selector and battery switch 180A.

Wall mounting hole Ø 70mm. Complete with L0610180.

| Articolo - Item | €/kit. | Ø mm. |
|-----------------|--------|-------|
| L 06 70 002 | | 70 |



COMPLETO DI-COMLETE WITH

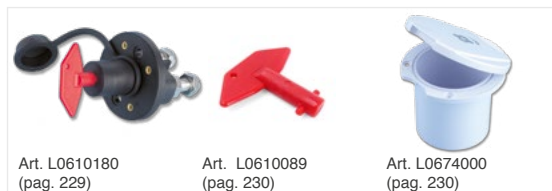

Art. L0610180 (pag. 229)

Art. L0610089 (pag. 230)

Art. L0674000 (pag. 230)



STACCABATTERIA E DEVIATORI | BATTERY SWITCHES

Interruttore-deviatore batterie

Max. 6-12-24-32V. Tensione 175A, Tensione Max 300A, 3 posizioni interruttore.

| Articolo - Item | €/pc. | VOLTS | kg. |
|-----------------|-------|-------|-------|
| L 06 17 540 | | 9-32 | 0,450 |

1 9-32V

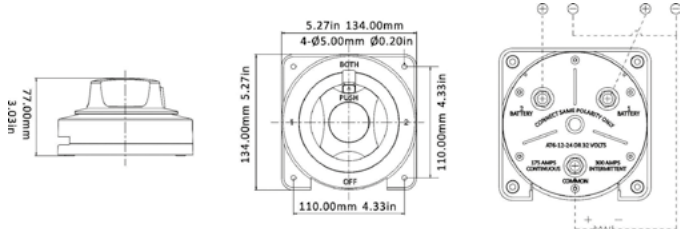

Battery selector switch

Max. Volt 6-12-24-32. Amp Draw 175A, Max Amp Draw 300A, Switch positions 3.

Deviatore staccabatteria

Deviatore staccabatteria compatto a quattro posizioni. Permette di staccare il circuito, di selezionare una delle due batterie, oppure entrambe in contemporanea.

Battery Switch

Four position battery switch: OFF, battery one, battery two, both batteries. Flush or recessed mounting.

| Articolo - Item | €/pc. | Capacità Capacity | Spunto max | VOLTS |
|-----------------|-------|-------------------|------------|-------|
| L 06 12 120 | | 175A | 300A | 9-32 |

1 9-32V

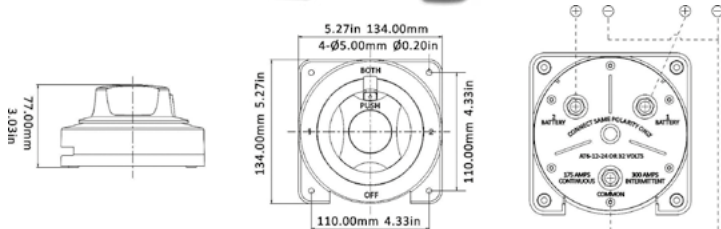

Staccabatteria mini

Max. 50V. Tensione 275A, Tensione Max 1250A, 2 posizioni interruttore.

| Articolo - Item | €/pc. | mm. | kg. |
|-----------------|-------|-----------|-------|
| L 06 27 520 | | 78x78xH80 | 0,200 |

1 9-32V



Battery solator switch

Max. Volt 50. Amp Draw 275A, Max Amp Draw 1250A, Switch positions 2.

Staccabatteria

Fabbricato in materiale plastico ed alluminio. Capacità 300A. in corrente continua e 1000A. per 10 secondi. 2 fori di fissaggio

Battery switch

In plastic material and aluminium. Capacity 300A. continuous. 1000A. for 30 sec.

| Articolo - Item | €/pc. | Ø mm. | kg. |
|-----------------|-------|-------|-------|
| L 06 10 091 | | 66 | 0,240 |

1 9-32V



Deviatore staccabatteria

Deviatore staccabatteria compatto a quattro posizioni. Permette di staccare il circuito, di selezionare una delle due batterie, oppure entrambe in contemporanea. Con chiave di sicurezza.

| Articolo - Item | €/pc. | Capacità Capacity | Spunto max | mm. |
|-----------------|-------|-------------------|------------|----------|
| L 06 00 400 | | 175A | 300A | Ø133xH65 |

1 9-32V



Battery Switch

Four position battery switch: OFF, battery one, battery two, both batteries. Flush or recessed mounting. With safety key.

Interruttore-deviatore batterie

150A.-12V. in continuo e 300A-6V. in continuo. 150A.-12VDC and 300A-6DC

Battery selector switch

| Articolo - Item | €/pc. | mm. | kg. |
|-----------------|-------|--------|-------|
| L 06 10 180 | | 140x70 | 0,300 |

1 12V



Contenitore per staccabatteria realizzato in Abs bianco

Case for battery manufactured in white Abs

| Articolo - Item | €/pc. | €/box | Incasso-Recess ø mm. |
|-----------------|-------|-------|----------------------|
| L 06 74 000 | | | 70 |

made by TPOWER



Chiave di ricambio

In materiale plastico

Spare key

In plastic material.

| Articolo - Item | €/pc. |
|-----------------|-------|
| L 06 13 066 | |

1



Chiave di ricambio

In materiale plastico

Spare key

In plastic material.

| Articolo - Item | €/pc. |
|-----------------|-------|
| L 06 10 089 | |

1 **NEW**



Stacca batteria

La manopola non può essere rimossa quando nelle posizioni ON-OFF, ma solo ruotando la stessa in senso anti-orario di 45°.
Dotato di coperchi rimovibili posteriori per prevenire contatti accidentali o corto circuiti sui collegamenti come richiesto dalle norme ABYC. Può essere montato a pannello o incassato (foro da 52,4 mm).

Caratteristiche tecniche:

- Portata continua: 275A DC
- Portata intermittente: 455A DC
- Portata allo spunto: 1250A DC
- Azione: ON/OFF
- Montaggio: incasso o superficie
- Misura terminali di collegamento: 2x10mm
- Perni e dadi in rame stagnato
- Conforme ai requisiti di antideflagranza

Battery Switch

Extractable knob moving 45° counterclockwise. It can not be removed in ON-OFF position. Complete with extractable back cover as per ABYC rules.
Flush or recessed mounting (hole 52,4 mm).

Technical features:

- Continulous capacity: 275A DC
- Intermittent capacity: 455A DC
- Max capacity: 1250A DC
- ON/OFF
- Flush or recessed mounting
- Terminal connectors: 2x10mm
- Tin-plated copper pins and nuts
- In compliance with anti deflagration rules



| Articolo - Item | €/pc. | Tensione Voltage |
|-----------------|-------|------------------|
| L 06 10 814 | | 48V DC |

1 **9-32V NEW** made by

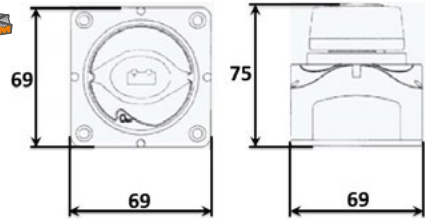

Stacca batteria montaggio a incasso

La manopola non può essere rimossa quando nelle posizioni ON-OFF, ma solo ruotando la stessa in senso anti-orario di 45°.
Dotato di coperchi rimovibili posteriori per prevenire contatti accidentali o corto circuiti sui collegamenti come richiesto dalle norme ABYC. Può essere montato a pannello o incassato (foro da 52,4 mm).

Caratteristiche tecniche:

- Portata continua: 275A DC
- Portata intermittente: 455A DC
- Portata allo spunto: 1250A DC
- Azione: ON/OFF
- Misura terminali di collegamento: 2x10mm
- Perni e dadi in rame stagnato
- Conforme ai requisiti di antideflagranza

Flush mount battery switch

Extractable knob moving 45° counterclockwise. It can not be removed in ON-OFF position. Complete with extractable back cover as per ABYC rules.
Flush or recessed mounting (hole 52,4 mm).

Technical features:

- Continulous capacity: 275A DC
- Intermittent capacity: 455A DC
- Max capacity: 1250A DC
- ON/OFF
- Terminal connectors: 2x10mm
- Tin-plated copper pins and nuts
- In compliance with anti deflagration rules

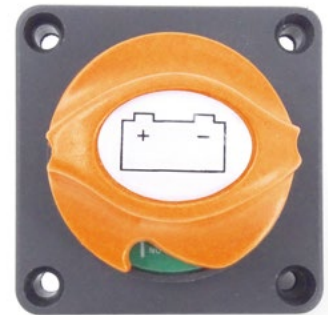

| Articolo - Item | €/pc. | Tensione Voltage |
|-----------------|-------|------------------|
| L 06 10 816 | | 48V DC |

1 **9-32V NEW** made by

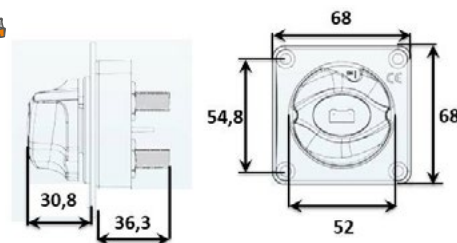

Deviatore per batterie

Il più compatto selettore disponibile sul mercato.
Attenzione: questo selettore non protegge gli apparati elettronici dallo spunto dei motori.

Caratteristiche tecniche:

- Portata continua: 200A DC
- Portata intermittente: 300A DC
- Portata allo spunto: 1000A DC
- Azione: batteria 1/batteria2/parallelo/spento
- Montaggio: incasso o superficie
- Misura terminali di collegamento: 3x8mm
- Perni e dadi in rame stagnato

Battery Switch

It cannot protect any electronic device from the breakaway torque of engines.

Technical features:

- Continulous capacity: 200A DC
- Intermittent capacity: 300A DC
- Max capacity: 1000A DC
- Battery 1/Battery 2/Parallel/OFF
- Flush or recessed mounting
- Terminal connectors: 3x8mm
- Tin-plated copper pins and nuts



| Articolo - Item | €/pc. | Tensione Voltage |
|-----------------|-------|------------------|
| L 06 10 815 | | 48V DC |

1 **9-32V NEW** made by

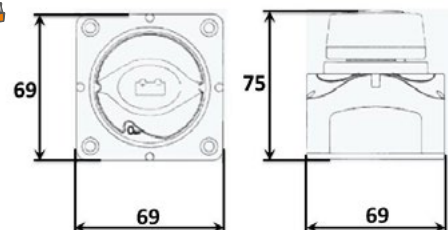



Inverter onda modificata 300W

Completo di display.

| | |
|------------------------------------|--------------------|
| Articolo - Item | L 06 12 300 |
| Modello-Model | 300 W - 12V |
| Voltaggio in entrata-Input Voltage | DC 12V |
| Voltaggio in uscita-Output Voltage | 230V AC +/- 10% |
| Potenza continua-DC current | 300 W |
| Potenza di picco-Peak current | 600 W |
| Peso-Weight kg. | 10,500 |
| Dimensioni-Size mm. P x L x H | 180x120x60 |
| €/pc. | |

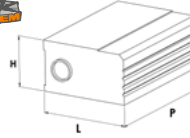

SUGGESTED ITEMS



CONTROLLO REMOTO (pag. 233)



Inverter onda modificata 500W

Completo di display.

| | |
|------------------------------------|--------------------|
| Articolo - Item | L 06 12 600 |
| Modello-Model | 500 W - 12V |
| Voltaggio in entrata-Input Voltage | DC 12V |
| Voltaggio in uscita-Output Voltage | 230V AC +/- 10% |
| Potenza continua-DC current | 500 W |
| Potenza di picco-Peak current | 1000 W |
| Peso-Weight kg. | 12,800 |
| Dimensioni-Size mm. P x L x H | 230x120x60 |
| €/pc. | |

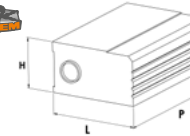

SUGGESTED ITEMS



CONTROLLO REMOTO (pag. 233)



Inverter onda modificata 1000W

Completo di display.

| | |
|------------------------------------|--------------------|
| Articolo - Item | L 06 22 100 |
| Modello-Model | 1000 W - 12V |
| Voltaggio in entrata-Input Voltage | DC 12V |
| Voltaggio in uscita-Output Voltage | 230V AC +/- 10% |
| Potenza continua-DC current | 1000 W |
| Potenza di picco-Peak current | 2000 W |
| Peso-Weight kg. | 11,000 |
| Dimensioni-Size mm. P x L x H | 320x180x80 |
| €/pc. | |

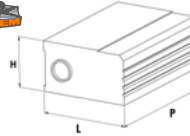

SUGGESTED ITEMS



CONTROLLO REMOTO (pag. 233)



Inverter onda modificata 1500W

Completo di display.

| | | |
|------------------------------------|--------------------|--------------------|
| Articolo - Item | L 06 22 150 | L 06 30 150 |
| Modello-Model | 1500 W - 12V | 1500 W - 24V |
| Voltaggio in entrata-Input Voltage | DC 12V | DC 24V |
| Voltaggio in uscita-Output Voltage | 230V AC +/- 10% | 230V AC +/- 10% |
| Potenza continua-DC current | 1500 W | 1500 W |
| Potenza di picco-Peak current | 3000 W | 3000 W |
| Peso-Weight kg. | 14,000 | 14,000 |
| Dimensioni-Size mm. P x L x H | 340x180x80 | 340x180x80 |
| €/pc. | | |

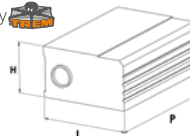

SUGGESTED ITEMS



CONTROLLO REMOTO (pag. 233)

Inverter onda modificata 2000W

Completo di display a LED.

| Articolo - Item | L 06 22 200 | L 06 40 200 |
|------------------------------------|-----------------|-----------------|
| Modello-Model | 2000 W - 12V | 2000 W - 24V |
| Voltaggio in entrata-Input Voltage | DC 12V | DC 24V |
| Voltaggio in uscita-Output Voltage | 230V AC +/- 10% | 230V AC +/- 10% |
| Potenza continua-DC current | 2000 W | 2000 W |
| Potenza di picco-Peak current | 4000 W | 4000 W |
| Peso-Weight kg. | 12,100 | 12,100 |
| Dimensioni-Size mm. P x L x H | 380x218x100 | 380x218x100 |

€/pc.

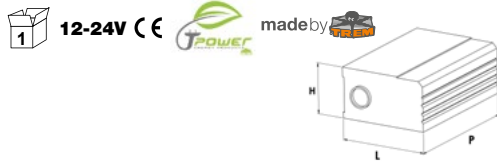

Modified sine wave inverter 2000W

Supplied with LED display.



SUGGESTED ITEMS



Inverter onda modificata 3000W

Completo di display a LED.

| Articolo - Item | L 06 12 317 | L 06 24 317 |
|------------------------------------|---------------------------|-----------------|
| Modello-Model | 3000 W - 12V | 3000 W - 24V |
| Voltaggio in entrata-Input Voltage | DC 12V | DC 24V |
| Voltaggio in uscita-Output Voltage | 230V AC +/- 10% | 230V AC +/- 10% |
| Potenza continua-DC current | 3000 W | 3000 W |
| Potenza di picco-Peak current | 6000 W | 6000 W |
| Peso-Weight kg. | 14,000 | 14,000 |
| Dimensioni-Size mm. P x L x H | 410x218x100 | 410x218x100 |
| USB | 2 Porte 1A - 2 Sockets 1A | |

€/pc.



Modified sine wave inverter 3000W

Supplied with LED display.



SUGGESTED ITEMS



Controllo remoto

Completo di cavo da 10 mt. e piastra di fissaggio.

| Articolo - Item | €/pc. | ↳ Esterne-Outer mm. | ↳ Incasso-Recess mm. |
|-----------------|-------|---------------------|----------------------|
| L 06 22 000 | | 100x60 | 52x42 |



Remote control

Complete with 10 mt. cable and fastening plate.



Inverter onda pura

Protezioni: sovraccarico, surriscaldamento, sovratensione in entrata, basso voltaggio in entrata e uscita, cortocircuito.

| Articolo - Item | L 06 08 150 |
|------------------------------------|---------------------------|
| Modello-Model | 1500W-12V |
| Voltaggio in entrata-Input Voltage | DC 12V |
| Voltaggio in uscita-Output Voltage | AC 220V-240V/AC 110V-120V |
| Potenza continua-DC current | 1500W |
| Potenza di picco-Peak current | 3000W |
| Frequenza di uscita-Exit frequency | 50Hz. |
| Peso-Weight kg. | 2,50 kg. |
| Dimensioni-Size mm. P x L x H | 335x203x78 |
| USB | DC 5V 500mA |
| Distorsione-Distortion | <3% |

€/pc.



Pure sine wave inverter

Protection specifications: Overload, Overheat, Input Overvoltage, Input Lowvoltage and Output Short-circuit protection.



SUGGESTED ITEMS



PRESE E SPINE «RATIO» | «RATIO» SOCKETS & PLUGS

Spina da incasso in poliammide 16A/250V

- Poliammide PA6
- Marchio CE
- Stagno grado di protezione IP56

Cutout power inlet made of polyamide 16A/250V

- Polyamide PA6
- CE marking
- IP56 waterproof

| Articolo - Item | €/pc. | kg. |
|-----------------|-------|-------|
| Z 20 16 045 | | 0,190 |

**Spina da incasso in acciaio inox Aisi 316 32A/250V**

- Acciaio inox Aisi 316
- Marchio CE
- Stagno grado di protezione IP56

Cutout power inlet Aisi 316 stainless steel

- Aisi 316 stainless steel
- CE marking
- IP56 waterproof

| Articolo - Item | €/pc. | kg. |
|-----------------|-------|-------|
| Z 20 32 032 | | 0,600 |

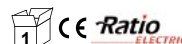
**Connettore 32A/250V**

Provvisto di marchio CE.
Cavo consigliato: H07BQ-F 3G 4,00mm2 e H07BQ-F 3G 6,00mm2.

Connector 32A/250V

CE marked.
Recommended cable: H07BQ-F 3G 4,00mm2 e H07BQ-F 3G 6,00mm2.

| Articolo - Item | €/pc. | kg. |
|-----------------|-------|-------|
| Z 20 32 110 | | 0,270 |

**Clip fissaggio banchina per cavo di alimentazione**

- Idonea per bordo banchina
- Ideale per tenere ordinati i cavi e al di sopra dell'acqua
- Facilità d'installazione
- Viti di fissaggio inox comprese

Shore power cord clips

- Suitable for dock
- Easy fitting
- With stainless steel screws

| Articolo - Item | €/box | Ideale per For Ø mm. | kg. |
|-----------------|-------|----------------------|-------|
| Z 20 70 041 | | 10 | 0,600 |

**Cavo da banchina**

- Colore giallo.
- Marchio CE.
- Stagno grado di protezione IP56.
- Led per indicazione di alimentazione.
- La presa è munita di tappo di protezione come richiesto dalle specifiche CE.

Shore power cable

- Yellow colour.
- CE marked.
- IP56 protection rate.
- Led Power indicator light.
- Complete with watertight connector cap to ensure CE compliance.

| Articolo - Item | €/pc. | Ø mm. | mm. ² | Cavo-Cable mt. | Amp. | kg. |
|-----------------|-------|-------|------------------|----------------|------|-------|
| Z 20 25 016 | | 10 | 3x2,5 | 25 | 16 | 4,750 |

**Cavo da banchina**

- Colore giallo.
- Marchio CE.
- Stagno grado di protezione IP56.
- Led per indicazione di alimentazione.
- La presa è munita di tappo di protezione come richiesto dalle specifiche CE.

Shore power cable

- Yellow colour.
- CE marked.
- IP56 protection rate.
- Led Power indicator light.
- Complete with watertight connector cap to ensure CE compliance.

| Articolo - Item | €/pc. | Ø mm. | mm. ² | Cavo-Cable mt. | Amp. | kg. |
|-----------------|-------|-------|------------------|----------------|------|-------|
| Z 20 56 032 | | 12 | 3x4 | 15 | 25 | 4,500 |





PRESE, SPINE E CAVI DI ALIMENTAZIONE «ELECTRA» | «ELECTRA» POWER INLETS, SOCKETS & SHORE CABLES

Spina 16A-250V

Realizzata in PA6 PVC con contatti in ottone argentato. Omologata CE ISO13297.

Plug 16A-250V

Manufactured in PA6 PVC with silver plated brass contacts. CE ISO13297.

| Articolo - Item | €/pc. | IP | Amp. | Volts | Cavo consigliato Suggested cable |
|-----------------|-------|----|------|-------|----------------------------------|
| Z 20 16 001 | | 56 | 16 | 250 | Z2016011 |



Presse 16A-250V

Realizzata in PA6 con contatti in ottone nichelato. Omologata CE ISO13297.

Socket 16A-250V

Manufactured in PA6 PVC with nickel plated brass contacts. CE ISO13297.

| Articolo - Item | €/pc. | IP | Amp. | Volts | A mm. | B mm. | C mm. |
|-----------------|-------|----|------|-------|-------|-------|-------|
| Z 20 10 002 | | 56 | 16 | 250 | 52 | 4 | 61 |



**AREA DI MONTAGGIO
FIXING AREA**

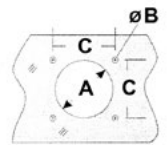

Cavo banchina

Colore giallo. Pre-cablato. Omologato CE ISO13297.

Wharf cable

Yellow colour. Pre-wired. CE ISO13297.

| Articolo - Item | €/pc. | Ø mm. | mm. ² | Cavo-Cable mt. | Amp. |
|-----------------|-------|-------|------------------|----------------|------|
| Z 20 10 015 | | 10 | 3x2,5 | 15 | 16 |
| Z 20 10 025 | | 10 | 3x2,5 | 25 | 16 |



COMPLETO DI-COMPLETE WITH



Cavo tripolare colore giallo

Three-pole cable, yellow colour

| Articolo - Item | €/mt. | €/100 | Matassa Reel mt. | Sezione cavo Cable section mm ² | Cavo-Cable Ø mm. | Capacità-Capacity Amp. 220V. | Spessore isolante Insulating thickness mm. |
|-----------------|-------|-------|------------------|--|------------------|------------------------------|--|
| Z 20 16 011 | | | 50 | 3 x 2,5 | 11 | 16 | 1,6 |
| Z 20 32 014 | | | 50 | 3 x 6 | 14 | 32 | 1,6 |





Spina di corrente a 7 poli

PVC plug 7 poles

| Articolo - Item | €/pc. | Mod. | kg. |
|-----------------|-------|------|-------|
| Z 20 05 197 | | 12V | 0,080 |



Pres a fissa a 7 poli con coperchio

PVC socket 7 poles with cover

| Articolo - Item | €/pc. | Mod. | kg. |
|-----------------|-------|------|-------|
| Z 20 04 217 | | 12V | 0,080 |



Spina di corrente a 13 poli

Plug 13 poles

| Articolo - Item | €/pc. | Mod. | kg. |
|-----------------|-------|------|-------|
| Z 20 01 013 | | 12V | 0,140 |



Pres a fissa a 13 poli con coperchio

Socket 13 poles with cover

| Articolo - Item | €/pc. | Mod. | kg. |
|-----------------|-------|------|-------|
| Z 20 12 013 | | 12V | 0,100 |



Microadattatore

Spina 13 poli + presa 7 poli 12V.

Microadaptor

13 pins, 7 plugs. 12V.

| Articolo - Item | €/pc. | Mod. | kg. |
|-----------------|-------|------|-------|
| Z 20 40 403 | | 12V | 0,080 |



Adattatori di corrente per carrelli

Power adaptor for boat trailers

| Articolo - Item | €/pc. | Mod. | kg. |
|-----------------|-------|---|-------|
| Z 20 13 007 | | da spina a 13 poli a presa 7 from pin 13 poles to plug 7 | 0,120 |
| Z 20 07 013 | | da spina a 7 poli a presa 13 from pin 7 poles to plug 13 | 0,070 |



Cavo prolunga rimorchio

Extension cable for boat trailer

| Articolo - Item | €/pc. | Lunghezza-Length mt. | Mod. |
|-----------------|-------|----------------------|--|
| O 10 07 005 | | 5 | presa volante 7 poli + spina 7 poli 7-pole socket + 7-pole plug |
| O 10 07 007 | | 7 | presa volante 7 poli + spina 7 poli 7-pole socket + 7-pole plug |
| O 10 07 010 | | 10 | presa volante 7 poli + spina 7 poli 7-pole socket + 7-pole plug |
| O 10 27 005 | | 5 | 2 spine 7 poli - 2x7-pole plugs |
| O 10 27 007 | | 7 | 2 spine 7 poli - 2x7-pole plugs |
| O 10 27 010 | | 10 | 2 spine 7 poli - 2x7-pole plugs |
| O 10 13 005 | | 5 | 2 spine 13 poli - 2x13-pole plugs |
| O 10 13 007 | | 7 | 2 spine 13 poli - 2x13-pole plugs |
| O 10 13 010 | | 10 | 2 spine 13 poli - 2x13-pole plugs |



Presa tripolare CE con coperchio

16A.

CE tripolar socket with cover

16A.

| Articolo - Item | €/pc. | mm. | V | IP | kg. |
|-----------------|-------|--------|-----|----|-------|
| Z 20 01 000 | | 130x50 | 230 | 44 | 0,120 |



Spina tripolare CE

16A.
Ideale per cavo Ø 6/12 mm.

CE tripolar plug

16A.
Suitable for Ø 6/12 mm cable.

| Articolo - Item | €/pc. | mm. | V | IP | kg. |
|-----------------|-------|--------|-----|----|-------|
| Z 20 01 100 | | 125x53 | 230 | 44 | 0,140 |



Presa a gomito CE/SCHUKO

16A.

Elbow plug CE/SCHUKO

16A.

| Articolo - Item | €/pc. | mm. | V | IP | kg. |
|-----------------|-------|-------------|-----|----|-------|
| Z 20 82 030 | | Ø50x90x115H | 250 | 44 | 0,160 |



Presa tripolare CE a parete con coperchio

16A.

CE tripolar socket with cover wall mount

16A.

| Articolo - Item | €/pc. | mm. | V | IP | kg. |
|-----------------|-------|-----------|-----|----|-------|
| Z 20 02 000 | | 130x70x30 | 250 | 44 | 0,180 |



Presa tripolare CE con coperchio

32A.
Ideale per cavo Ø 6/12 mm.

CE tripolar socket with cover

32A.
Suitable for Ø 6/12 mm cable.

| Articolo - Item | €/pc. | mm. | V | IP | kg. |
|-----------------|-------|--------|-----|----|-------|
| Z 20 01 105 | | 160x65 | 250 | 44 | 0,220 |



Spina tripolare CE

32A.
Ideale per cavo Ø 6/12 mm.

CE tripolar plug

32A.
Suitable for Ø 6/12 mm cable.

| Articolo - Item | €/pc. | mm. | V | IP | kg. |
|-----------------|-------|--------|-----|----|-------|
| Z 20 01 005 | | 160x95 | 250 | 44 | 0,170 |



Spina CE a parete

32A.

CE tripolar plug wall mount

32A.
Suitable for Ø 11/18 mm cable.

| Articolo - Item | €/pc. | mm. | V | IP | kg. |
|-----------------|-------|-----------|-----|----|-------|
| Z 20 01 205 | | 160x80x84 | 250 | 44 | 0,180 |



Spina tripolare CE con coperchio

16A.
Ideale per cavo Ø 11/18 mm.

CE tripolar plug with cover

16A.
For cable Ø 11/18 mm.

| Articolo - Item | €/pc. | mm. | V | kg. |
|-----------------|-------|------------|-----|-------|
| Z 20 82 103 | | 160x100x80 | 250 | 0,350 |



Spina CE

16A.

CE plug

16A.

| Articolo - Item | €/pc. | mm. | V | kg. |
|-----------------|-------|-------------|-----|-------|
| Z 20 82 113 | | 115x110x100 | 240 | 0,240 |





Z2082024-018-181
Z2005092

Z2000010-025

Prolunga 16A, IP44

Spina e presa Cee-Cee.
Cavo in Neoprene.

Extension cable 16A, IP44

Cee-Cee plug and socket.
Neoprene cable.

| Articolo - Item | €/pc. | Mod. | mt. | Amp. | IP | kg. |
|-----------------|-------|-------------------------------|-----|------|----|-------|
| Z 20 82 024 | | H07RN-F3G 1,5 mm ² | 10 | 16 | 44 | 1,750 |
| Z 20 05 092 | | H07RN-F3G 1,5 mm ² | 25 | 16 | 44 | 5,200 |
| Z 20 82 018 | | H07RN-F3G 2,5 mm ² | 10 | 16 | 44 | 2,300 |
| Z 20 82 181 | | H07RN-F3G 2,5 mm ² | 25 | 16 | 44 | 6,700 |
| Z 20 00 010 | | Sacca per-Bag for 10mt. | | | | |
| Z 20 00 025 | | Sacca per-Bag for 25mt. | | | | |



Prolunga CE/SCHUKO

16A. IP44.
Lunghezza 1,5 mt.

CE/SCHUKO Extension cable

16A. IP44.
Length 1,5 mt.



| Articolo - Item | €/pc. | Spina-Plug | Accoppiatore Coupler | Mod. | V | Amp. | IP | kg. |
|-----------------|-------|------------|----------------------|-----------------------|-----|------|----|-------|
| Z 20 08 180 | | CEE | CEE | 3x2,5 mm ² | 250 | 16 | 44 | 0,600 |
| Z 20 08 270 | | Schuko | CEE | 3x2,5 mm ² | 250 | 16 | 44 | 0,400 |
| Z 20 82 022 | | CEE | Schuko | 3x2,5 mm ² | 250 | 16 | 44 | 0,500 |



Adattatore CE/SCHUKO

16A.

CE/SCHUKO Extension cable

16A.



| Articolo - Item | €/pc. | Spina-Plug | Mod. | V | Amp. | kg. |
|-----------------|-------|------------|-------------------------------|-----|------|-------|
| Z 20 82 035 | | Schuko-CEE | H07RN-F3Gx1,5 mm ² | 250 | 16 | 0,240 |



Ciabatta a 3 prese e porta USB CE con coperchio

CE Three way and USB socket with cover



| Articolo - Item | €/pc. | Mod. | mt. |
|-----------------|-------|-------------------------------|-----|
| Z 20 03 015 | | H07RN-F3Gx1,5 mm ² | 1,5 |



Ciabatta CE/SCHUKO a 4 prese con coperchio

CE/SCHUKO Extension 4 outlets cable with cover

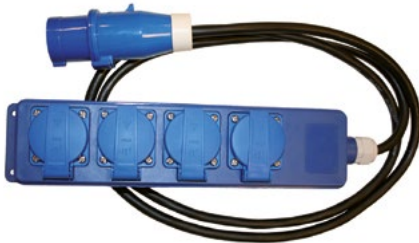

Provvista di cavo in neoprene 3 x 1,5 mm².
16A.

Provided with neoprene cable
3 x 1,5 mm². 16A.

| Articolo - Item | €/pc. | Mod. | mt. | Amp. | kg. |
|-----------------|-------|-----------------------|-----|------|-------|
| Z 20 46 503 | | 3x1,5 mm ² | 1,5 | 16 | 1,000 |



Presca tripla SCHUKO 230V-12V. antenna TV

Triple socket SCHUKO 230V-12V. TV antenna



| Articolo - Item | €/pc. | Mod. | Cavo-Cable mt. | Amp. | kg. |
|-----------------|-------|-----------------------|----------------|------|-------|
| Z 20 82 016 | | 3x1,5 mm ² | 1,0 | 16 | 1,000 |



Contenitore impermeabile per prolunghe

Waterproof holder for extension lead

| Articolo - Item | €/pc. | ↑ mm. | Per prese For socket | kg. |
|-----------------|-------|---------|----------------------|-------|
| Z 20 82 043 | | Ø95x365 | 16A | 0,320 |



Impugnatura per cavi

Cable handle

| Articolo - Item | €/pc. | ↑ mm. | kg. |
|-----------------|-------|--------|-------|
| Z 20 02 090 | | 180x90 | 0,080 |



Arrotolatore per cavi e tubi provvisto di maniglia

Cable and hose handle

| Articolo - Item | €/pc. | ↑ mm. |
|-----------------|-------|------------|
| Z 20 01 090 | | 378x168x67 |



Spina e presa stagna 10A.

Fabbricate in ottone cromato, Ø 42 mm. Provviste di tappo di protezione da avvitare, fissato alla presa con una catenella.

Waterproof plug & socket 10A.

Made of brass chromed plated housing. Ø 42 mm. Provided with protection cap and chain.

| Articolo - Item | €/pc. | Mod. | Ø base mm. | Amp. | kg. |
|-----------------|-------|-------------|------------|------|-------|
| L 06 42 110 | | Bipolar | 42 | 10 | 0,200 |
| L 06 42 115 | | Tripolar | 42 | 10 | 0,200 |
| L 06 42 120 | | Quadripolar | 42 | 10 | 0,200 |



Spina e presa stagna 5A.

Fabbricate in ottone cromato, Ø 38 mm. Provviste di tappo di protezione da avvitare, fissato alla presa con una catenella.

Waterproof plug & socket 5A.

Made of brass chromed plated housing. Ø 38 mm. Provided with protection cap and chain.

| Articolo - Item | €/pc. | Mod. | Ø base mm. | Amp. | kg. |
|-----------------|-------|-------------|------------|------|-------|
| L 06 38 080 | | Bipolar | 38 | 5 | 0,100 |
| L 06 38 085 | | Tripolar | 38 | 5 | 0,100 |
| L 06 38 090 | | Quadripolar | 38 | 5 | 0,100 |



Spina e presa stagna bipolare 3A.

Carico massimo 3A. Ideale per fari e lampade portatili. Fabbricata in ottone cromato e tappo di protezione.

Waterproof plug & socket 3A.

Maximum load 3A. Made of brass chromed plated housing. Provided with protection cap.

| Articolo - Item | €/kit. | Mod. | Ø base mm. | Amp. | kg. |
|-----------------|--------|--------------|------------|------|-------|
| L 06 36 048 | | 2 poli-poles | 36 | 3 | 0,130 |

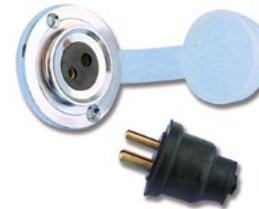

Premistoppa stagno

Indicati per passaggio cavi. Fabbricati in ottone cromato e gomma antisalina.

Waterproof fairlead gland

Suitable for cable connection. Manufactured in chromed brass and rubber.

| Articolo - Item | €/pc. | Per spine stagne | | Amp. | kg. |
|-----------------|-------|----------------------|-----------------|------|-------|
| | | For waterproof plugs | For cable Ø mm. | | |
| L 06 31 013 | | 3A. | 6 | 3 | 0,030 |
| L 06 08 003 | | 3A. | 8 | 3 | 0,030 |
| L 06 10 003 | | 3A. | 10 | 3 | 0,050 |

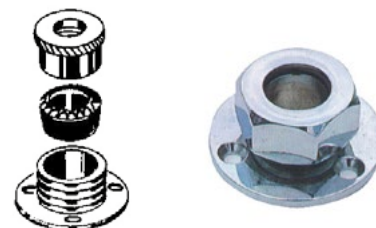

PRESE E SPINE | SOCKETS & PLUGS

**Spinotto accendisigari**

Con fusibile 8A.

Cigarette lighter plug

Fuse 8A.

| Articolo - Item | €/pc. | Volts | kg. |
|-----------------|-------|-------|-------|
| L 06 12 008 | | 12 | 0,020 |

**Spina accendisigari****Cigarette lighter plug**

| Articolo - Item | €/pc. | Volts | kg. |
|-----------------|-------|-------|-------|
| L 06 00 191 | | 12 | 0,010 |

**Spinotto per prese****Standard plug**

| Articolo - Item | €/pc. | Volts | kg. |
|-----------------|-------|-------|-------|
| Z 20 81 012 | | 12 | 0,010 |

**Presi 12V**

Fabbricata in ottone cromato.

12V Connector

Manufactured in chromed brass.

| Articolo - Item | €/pc. | Volts | kg. |
|-----------------|-------|-------|-------|
| L 06 00 030 | | 12 | 0,040 |

**Presi accendisigari**

Fabbricata in ottone cromato.

Cigarette lighter connector

Manufactured in chromed brass.

| Articolo - Item | €/pc. | Volts |
|-----------------|-------|-------|
| L 06 00 192 | | 12 |

**Presi accendisigari montaggio a vite**

Fabbricata in nylon nero.

Cigarette lighter connector screw mounting

Manufactured in black nylon.

| Articolo - Item | €/kit. | mm. | Prese-Sockets | Volts | kg. |
|-----------------|--------|--------------------|---------------|-------|-------|
| L 06 01 335 | | Ø interno-inner 20 | 1 | 12 | 0,050 |

**Presi accendisigari completa di carenatura e guarnizioni**

Montaggio verticale e orizzontale.

Cigarette lighter connector

Vertical and horizontal mounting.

| Articolo - Item | €/pc. | mm. | Volts | kg. |
|-----------------|-------|----------|-------|-------|
| L 06 01 331 | | 80x65x43 | 12 | 0,100 |



Accendisigari marino

Completamente in acciaio inox, sia ricettacolo che accendino/plafoniera. Completo di luce carteggio sul pomolo con accensione separata.

Marine cigarette lighter

Manufactured in stainless steel. Complete with reading light.

| Articolo - Item | €/kit. | Volts | kg. |
|-----------------|--------|-------|-------|
| L 06 00 012 | | 12 | 0,110 |



Presa e spina accendisigari

Completamente impermeabile. Montaggio presa con dado posteriore. Standard per accendisigari e telefonini.

Socket and cigarette lighter plug

Fully waterproof. Socket mounting with nut.

| Articolo - Item | €/kit. | Volts | kg. |
|-----------------|--------|-------|-------|
| L 06 01 338 | | 12 | 0,070 |



Presa e spina accendisigari

Realizzate in plastica. Presa con cappuccio in gomma.

Socket and cigarette lighter plug

Manufactured in plastic. Socket with rubber cap.

| Articolo - Item | €/kit. | Volts | kg. |
|-----------------|--------|-------|-------|
| L 06 15 191 | | 12 | 0,070 |



COMPLETO DI-COMLETE WITH



Art. L0600191 (pag. 240)

Art. L0600192 (pag. 240)



Sdoppiatore di alimentazione

Inserito all'interno di una presa accendisigari, permette di collegare due utenze. Completo di LED luminoso indicante l'attivazione.

Double cigarette lighter connector

Complete with LED power indicator.

| Articolo - Item | €/pc. | Volts | kg. |
|-----------------|-------|-------|-------|
| L 06 01 332 | | 12 | 0,070 |



Presa tripla con prolunga

Provvista di 50 cm. di prolunga. Standard per accendisigari.

Three cigarette lighter connector

Supplied with 50 cm. cable.

| Articolo - Item | €/pc. | Cavo-Cable cm. | Volts | kg. |
|-----------------|-------|----------------|-------|-------|
| L 06 01 333 | | 50,00 | 12 | 0,130 |



Presa quadrupla con prolunga

Provvista di 50 cm. di prolunga. Standard per accendisigari.

Four cigarette lighter connector

Supplied with 50 cm. cable.

| Articolo - Item | €/pc. | Cavo-Cable cm. | Volts | kg. |
|-----------------|-------|----------------|-------|-------|
| L 06 00 244 | | 50,00 | 12 | 0,190 |





Presa USB per accendisigari

Tensione in ingresso: 12-24VDC.

| Articolo - Item | €/pc. | mm. |
|-----------------|-------|--------|
| L 06 01 342 | | Ø26x40 |



USB socket for cigarette lighter

12-24VDC.

| mm. | USB Port | kg. |
|--------|----------|-------|
| Ø26x40 | 1 | 0,020 |



Doppia presa USB per accendisigari

Tensione in ingresso: 12-24VDC.
Colore nero.

| Articolo - Item | €/pc. | mm. |
|-----------------|-------|----------|
| L 06 02 348 | | 63x39x36 |



Double USB socket for cigarette lighter

12-24VDC.
Black colour.

| mm. | USB Port | kg. |
|----------|----------|-------|
| 63x39x36 | 2 | 0,050 |



Tripla presa USB per accendisigari

Colore bianco.

| Articolo - Item | €/pc. | USB Port | Volts | Amp. | kg. |
|-----------------|-------|----------|-------|---------|-------|
| L 06 00 785 | | 3 | 12 | max 4,8 | 0,050 |



Three USB socket for cigarette lighter

White colour.

| USB Port | Volts | Amp. | kg. |
|----------|-------|---------|-------|
| 3 | 12 | max 4,8 | 0,050 |



Quadrupla presa USB per accendisigari

Completa di LED luminoso.
Colore bianco.

| Articolo - Item | €/pc. | USB Port | Volts | Amp. | kg. |
|-----------------|-------|----------|-------|---------|-------|
| L 06 00 588 | | 4 | 12 | max 4,8 | 0,060 |



Four USB socket for cigarette lighter

With LED.
White colour.

| USB Port | Volts | Amp. | kg. |
|----------|-------|---------|-------|
| 4 | 12 | max 4,8 | 0,060 |



Presa su corrente con doppio USB

Double USB switch

| Articolo - Item | €/pc. | Mod. | mm. | Volts | Amp. |
|-----------------|-------|-------------------------------------|----------|-------|---------|
| L 06 00 640 | | Presa doppia USB Double USB port | 49x25x51 | 12/24 | 2,1+1,0 |



Voltmetro digitale con 2 prese USB e presa di corrente montaggio su piano

Realizzato in ABS.
Prese USB: 5V 1A + 5V 2,1A.
Voltmetro 9-32V.

| Articolo - Item | €/pc. | H mm. | Lunghezza Length mm. | Profondità Width mm. |
|-----------------|-------|-------|----------------------|----------------------|
| L 06 00 644 | | 55 | 160 | 75 |



Digital voltmeter with 2 USB sockets and cigarette lighter flush mount

Manufactured in ABS.
USB socket: 5V 1A + 5V 2,1A.
Voltmeter 9-32V.

| H mm. | Lunghezza Length mm. | Profondità Width mm. |
|-------|----------------------|----------------------|
| 55 | 160 | 75 |

Doppia presa USB

Completamente impermeabile.
Montaggio a vite

| Articolo - Item | €/pc. | Colore-Colour | Amp. | kg. |
|-----------------|-------|---------------|-------|-------|
| L 06 02 435 | | Nero-Black | 2,1+1 | 0,040 |
| L 06 74 435 | | Bianco-White | 2,1+1 | 0,040 |

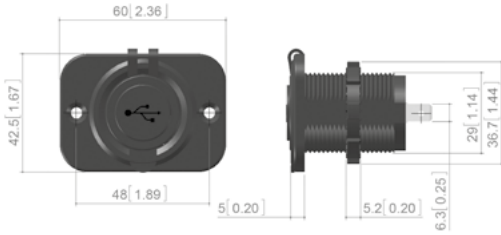

Doppia presa USB + 1 presa accendisigari

Completamente impermeabile.
Montaggio a vite

| Articolo - Item | €/pc. | Colore-Colour | Amp. | kg. |
|-----------------|-------|---------------|-------|-----|
| L 06 03 028 | | Nero-Black | 2,1+1 | |
| L 06 74 516 | | Bianco-White | 2,1+1 | |

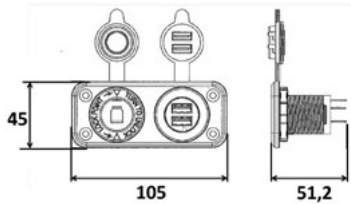

Doppia presa USB + Voltmetro

Completamente impermeabile.
Montaggio a vite

| Articolo - Item | €/pc. | Colore-Colour | Amp. | kg. |
|-----------------|-------|---------------|-------|-----|
| L 06 03 603 | | Nero-Black | 2,1+1 | |

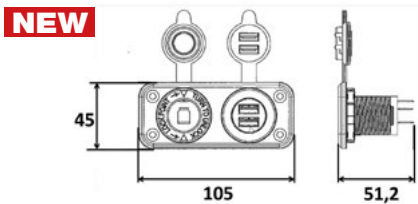

Presa accendisigari + Voltmetro + Amperometro + 2 Porte USB

Completamente impermeabile.
Montaggio a vite

| Articolo - Item | €/pc. | Amp. | kg. |
|-----------------|-------|-------|-----|
| L 06 10 599 | | 2,1+1 | |



Voltmetro

Completamente impermeabile.
Montaggio a vite

| Articolo - Item | €/pc. | kg. |
|-----------------|-------|-----|
| L 06 10 595 | | |



Voltmeter socket

Fully waterproof.
Screw mounting.



Pannello elettrico Compact con Circuit Breaker + LED IP66

Carcassa in policarbonato nero. Interruttori a bascula con incorporato LED di consenso. Provvisti di circuit breaker automatici riarmabili. Utenze con scritte retroilluminate con LED rosso se fuori servizio, con LED verde quando attive.

Compact switch panel with circuit breaker and LED IP66

Manufactured in black polycarbonate. Switches with built-in LED. Complete with resettable automatic circuit breakers. Backlit indicators with red LED when turned OFF, green LED when turned ON.

| Articolo - Item | €/pc. | N. Interruttori Switches N. | Tipo interruttori Switches type | Potenza Circuit Breaker | ↑ mm. |
|-----------------|-------|--------------------------------|---|----------------------------|---------|
| L 06 60 004 | | 4 | 1°/2°/3°=ON-OFF;4°=(ON)-OFF | 1x5A; 2x10A; 1x15A | 110x100 |
| L 06 60 006 | | 6 | 1°/2°/3°/ 4°/5° =ON-OFF;6°=(ON)-OFF | 2x5A; 2x10A; 2x15A | 160x100 |
| L 06 60 008 | | 8 | 1°/2°/3°/ 4°/5°/6°/7° =ON-OFF;8°=(ON)-OFF | 4x5A; 2x10A; 2x15A | 215x100 |



Moduli supplementari per pannelli

Possono essere allineati con i pannelli L0660004/L0660006/L0660008, oppure utilizzati in modo indipendente.

Extra modules for panel switches

Can be used with panels L0660004/L0660006/L0660008, or stand-alone.

| Articolo - Item | €/pc. | Funzione Function | Potenza Circuit Breaker | ↑ mm. |
|-----------------|-------|---|----------------------------|--------|
| L 06 60 011 | | Presse corrente Power socket | 1x15A | 60x100 |
| L 06 60 012 | | Doppio USB (2,1+1,0 A) Double USB (2,1+1,0 A) | 1x5A | 60x100 |
| L 06 60 013 | | Accendino Lighter plug | 1x10A | 60x100 |
| L 06 60 014 | | Voltmetro digitale 12/24 V 12/24V digital voltmeter | 1x5A | 60x100 |
| L 06 60 015 | | Doppio voltmetro digitale batt1/batt 2 Double digital voltmeter batt1/batt2 | 1x5A | 60x100 |
| L 06 60 016 | | Interruttore pompa sentina manuale/automatica Manual/automatic bilge pump switch | 1x10A | 60x100 |
| L 06 60 017 | | Battery Test | - | 60x100 |



Pannello elettrico con interruttori a bascula con LED IP54

Fabbricati in plastica nera, sono completi di interruttori a bascula e fusibili automatici termici riarmabili. Completi di adesivi per identificare le varie utenze.

Switch panel with circuit breaker and LED IP54

Manufactured in black plastic, complete with resettable automatic thermal breakers. With labels.

| Articolo - Item | €/pc. | N. Interruttori Switches N. | Interruttori Switches | Fusibili in dotazione Supplied fuses | Portafusibili Fuses holder | ↑ mm. |
|-----------------|-------|--------------------------------|--------------------------|---|-------------------------------|---------|
| L 06 10 024 | | 4 | L0624002 | 4Ax1+6Ax1+8Ax1+10Ax1 | L0661103-L0661104-L0661105 | 110x100 |
| L 06 10 026 | | 6 | L0624002 | 5Ax2+6Ax2+8Ax1+10Ax1 | L0661103-L0661104-L0661105 | 160x100 |
| L 06 10 028 | | 8 | L0624002 | 4Ax1+5Ax2+6Ax2+8Ax2+10Ax1 | L0661103-L0661104-L0661105 | 210x100 |



COMPLETO DI-COMPLETE WITH



Pannelli elettrici impermeabili, con voltmetro digitale

Piastra in lega leggera. Interruttori IP65. Spia a LED e portafusibili. 12VDC.

Waterproof switch panels, with digital voltmeter

Made in aluminium plate. IP65 switches. Waterproof switch with LED indication. 12VDC.

| Articolo - Item | €/pc. | Funzione Function | mm. | Interruttori Switches | Portafusibili Fuses holder | Tappi gomma Rubber caps | kg. |
|-----------------|-------|---|-------------|--------------------------|-------------------------------|----------------------------|-------|
| L 06 10 136 | | 3 int. + volt. digitale + 2 presa accendisigari 3 + dig. voltmeter + 2 cigarette lighter plugs | 190,5x133,5 | L0601033 L0683002 | L0661003 L0615061 | L0636007 L0661006 | 0,460 |
| L 06 10 142 | | 4 int. + voltmetro digitale 4 + digital voltmeter | 190,5x133,5 | L0601033 L0683002 | L0661003 L0615061 | L0636007 L0661006 | 0,480 |
| L 06 10 162 | | 6 int. + voltmetro digitale 6 + digital voltmeter | 241,5x114,5 | L0601033 L0683002 | L0661003 L0615061 | L0636007 L0661006 | 0,500 |



L0610136



L0610142



L0610162

COMPLETO DI-COMLETE WITH



INTERRUTTORI SWITCHES (pag. 250)

PORTAFUSIBILI FUSES HOLDER (pag. 250)

CAPPUCCI CAPS (pag. 251)

Pannello elettrico

Interruttori ON-OFF tranne il primo (ON-OFF-ON) e l'ultimo (ON-OFF) con ritorno a molla per tromba. Grado di protezione IP56. Interruttori a levetta luminosi. Fusibili automatici riarmabili. Pannello in alluminio verniciato con resine epossidiche.

Electric panel

ON-OFF switch, ON-OFF-ON, ON-OFF with spring return for horn. IP56. Resettable automatic fuses. Panel manufactured in painted aluminium with epossidic resins.

| Articolo - Item | €/pc. | N. Interruttori Switches N. | Fusibili riarmabili Resettable fuses | mm. | kg. |
|-----------------|-------|-----------------------------------|---|--------|-------|
| L 06 03 000 | | 3 | 2-10A 1-15A | 90x90 | 0,200 |
| L 06 04 000 | | 3+Pulsante tromba | 2-10A 2-15A | 170x90 | 0,250 |
| L 06 06 000 | | 5+1 Presa corrente/Accendino | 3-10A 2-15A 1-5A | 170x90 | 0,360 |
| L 06 06 001 | | 4+Pulsante tromba+Presa accendino | 3-10A 3-15A | 200x90 | 0,360 |



L0603000



L0604000



L0606000



L0606001

Pannello in nylon con interruttori a bascula luminosi

Versione verticale.

Electric panel

Manufactured in nylon.

| Articolo - Item | €/pc. | N. Interruttori Switches N. | Carico max Max load Amp | Completo di Complete with | Fusibili vetro mm. | mm. | Interruttori Switches | Portafusibili Fuses holder | kg. |
|-----------------|-------|--------------------------------|----------------------------|----------------------------------|-----------------------|---------|----------------------------------|--|-------|
| L 06 17 115 | | 6 | 10 cad/each | - | 6x32 | 165x114 | L0600001 | L0665004 L0665005 L0665004 | 0,200 |
| L 06 12 101 | | 3+ | 10 cad/each | 1 Accendisigari 1 Voltmetro | 6x32 | 127x114 | L0600001 L0683002 | L0683006 L0683007 L0683008 L0665004 | 0,240 |
| L 06 12 100 | | 3+ | 10 cad/each | 1 Pulsante tromba 1 Voltmetro | 6x32 | 127x114 | L0600001 L0683002 L0608025 | L0683006 L0683007 L0683008 | 0,290 |

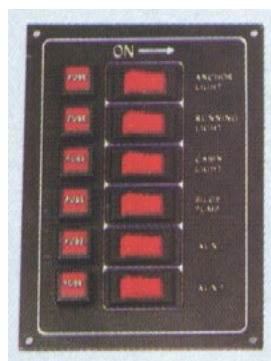

COMPLETO DI-COMLETE WITH



INTERRUTTORI SWITCHES (pag. 250)

PORTAFUSIBILI FUSES HOLDER (pag. 250)

PANNELLI ELETTRICI | SWITCH PANELS

Pannello di comando «Serie Pilot»

Funzionamento 12V.- 10A.

Electrical panel «Serie Pilot»

12V. - 10A.

| Articolo - Item | €/pc. | N. Interruttori Switches N. | Colore Colour | ↑ mm. | Fusibili Fuses | Interruttori Switches | Portafusibili Fuses holder | Tappi gomma Rubber caps | kg. |
|-----------------|-------|----------------------------------|------------------|---------|-------------------|--------------------------|-------------------------------|----------------------------|-------|
| L 06 10 044 | | 4 | ■ | 110x95 | 10A | L0644002 | L0644005 | L0611000 | 0,260 |
| L 06 74 044 | | 4 | □ | 110x95 | 10A | L0644002 | L0644005 | L0611000 | 0,260 |
| L 06 10 064 | | 6+LED | ■ | 110x125 | 10A | L0644002 | L0664004 | L0611000 | 0,350 |
| L 06 74 064 | | 6+LED | □ | 110x125 | 10A | L0644002 | L0664004 | L0611000 | 0,350 |
| L 06 22 108 | | 5+Accendino Cigarette lighter | ■ | 110x125 | 10A | L0644002 | L0664004 | L0611000 | 0,310 |

1 12V

COMPLETO DI-COMLETE WITH

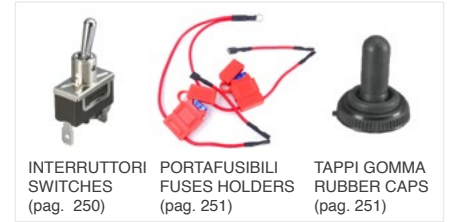

L0610064



L0674064



L0622108



L0610044



L0674044

Pannelli elettrici con interruttori stagni «Serie Boat»

Pannelli elettrici ad interruttori stagni con cappucci in gomma, completi di portafusibili e fusibili da 15A., con fori fissaggio rinforzati.

Electrical panels with waterproof switches «Boat Series»

With rubber caps. Complete with fuses holder and fuses 15A. Reinforced fastening holes.

| Articolo - Item | €/pc. | N. Interruttori Switches N. | Scasso Recess mm. | ↑ mm. (Esterne-Outer) | kg. |
|-----------------|-------|---|----------------------|--------------------------|-------|
| L 06 91 339 | | 3 + presa accendisigari 3 + cigarette lighter plug | 75x80 | 107x96 | 0,250 |
| L 06 91 341 | | 5 + presa accendisigari 5 + cigarette lighter plug | 85x90 | 107x96 | 0,270 |
| L 06 91 342 | | 6 | 85x90 | 107x96 | 0,270 |

1 IP64 12V



Pannelli interruttori 9-32V

SPST/ON-OFF/3P/1LED, tipo interruttori.

Rocker switch panel 9-32V

SPST/ON-OFF/3P/1LED, circuit breakers type.

| Articolo - Item | €/pc. | N. Interruttori Switches N. | Portafusibili Fuse holder | Taglio Cutout mm. |
|-----------------|-------|--|------------------------------|--------------------------|
| L 06 60 084 | | 4 pulsanti - rockers | 5A*2, 10A*1, 15A*1 | 90 (3,55") x 104 (4,09") |
| L 06 60 086 | | 6 pulsanti - rockers | 5A*3, 10A*2, 15A*1 | 90 (3,55") x 160 (6,30") |
| L 06 60 088 | | 8 pulsanti - rockers | 5A*4, 10A*2, 15A*2 | 90 (3,55") x 210 (8,27") |
| L 06 60 081 | | presa di corrente + presa doppia USB power socket + double USB socket | - | 90 (3,55") x 40 (1,58") |

1 9-32V

L0660084



L0660086



L0660088



L0660081



Pannello di comando stagno in alluminio anodizzato nero con spia

Waterproof electrical panel black anodised aluminium

Piastra in lega leggera con interruttori a tenuta stagna. Spia a led e porta fusibili.

Plate in light alloy with waterproof switches. Led light and fuse holder.

| Articolo - Item | €/pc. | N. Interruttori Switches N. | ↑ mm. | Interruttori Switches | Portafusibili Fuses holder | kg. |
|-----------------|-------|--------------------------------|---------|--------------------------|-------------------------------|-------|
| L 06 10 067 | | 15Ax6 | 190x130 | L0601033 | L0610003-L0637103 | 0,410 |
| L 06 10 047 | | 15Ax4 | 130x95 | L0601033 | L0610003-L0637103 | 0,210 |
| L 06 05 147 | | 15Ax5+USB 2,1A | 150x95 | L0601033 | L0610003-L0637103 | 0,330 |

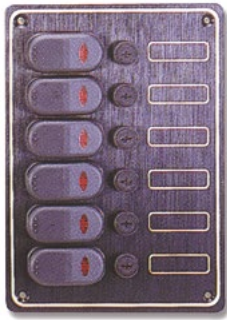

L0610067



L0610047



L0605147

COMPLETO DI-COMLETE WITH



INTERRUTTORI
SWITCHES
(pag. 250)

PORTAFUSIBILI
FUSES HOLDER
(pag. 250)

Pannello di comando stagno in alluminio anodizzato nero con spia

Waterproof electrical panel in black anodised aluminium

Piastra in lega leggera con interruttori a tenuta stagna. Spia a led e porta fusibili. Fusibili riarmabili.

With luminous Led and fuse-holder. Resettable fuses.

| Articolo - Item | €/pc. | N. Interruttori Switches N. | Scasso Recess mm. | ↑ mm. (Esterne-Outer) | Interruttori Switches | Portafusibili Fuses holder | Tappi gomma Rubber caps | kg. |
|-----------------|-------|--|----------------------|--------------------------|----------------------------------|----------------------------------|----------------------------|-------|
| L 06 10 032 | | 3 Interruttori-switches | - | 100x90 | L0632003 L0632004 L0632005 | L0661003 L0610061 L0661006 | L0620000 L0661006 | 0,160 |
| L 06 10 052 | | 5 Interruttori-switches + presa accendisigari + cigarette lighter plug | 145x80 | 192x102 | L0632003 L0632004 L0632005 | L0661003 L0610061 L0661006 | L0620000 L0661006 | 0,360 |



L0610032



L0610052

COMPLETO DI-COMLETE WITH



INTERRUTTORI
SWITCHES
(pag. 250)

PORTAFUSIBILI
FUSES HOLDER
(pag. 250-251)

TAPPO GOMMA
RUBBER PLUG
(pag. 251)

Pannelli elettrici

Electrical panels

Fabbricato in plastica. Fusibili riarmabili.

Manufactured in plastic. Resettable fuses.

| Articolo - Item | €/pc. | N. Interruttori Switches N. | Colore Colour | ↑ mm. | Interruttori Switches | Portafusibili Fuses holder | Tappo gomma Rubber cap | kg. |
|-----------------|-------|--------------------------------|------------------|---------|--------------------------|--|---------------------------|-------|
| L 06 80 016 | | 6 | ■ Nero-Black | 190x130 | L0633001 | L0661003 L0610061 L0615061 L0661003 | L0661006 | 0,430 |
| L 06 74 016 | | 6 | □ Bianco-White | 190x130 | L0633001 | L0610061 L0615061 L0661003 | L0661006 | 0,430 |
| L 06 80 013 | | 3 | ■ Nero-Black | 130x110 | L0633001 | L0610061 L0661003 L0615061 | L0661006 | 0,220 |



L0680016



L0674016



L0680013

COMPLETO DI-COMLETE WITH



INTERRUTTORI
SWITCHES
(pag. 250)

PORTAFUSIBILI
FUSES HOLDER
(pag. 250-251)

TAPPO GOMMA
RUBBER PLUG
(pag. 251)

PANNELLI ELETTRICI | SWITCH PANELS

Pannello di comando «Serie Sea»

Funzionamento 12V. - 5A.
Capacità ogni interruttore 10A.
Pannello di colore nero.
Fusibili 6,35 x 32 mm.
Senza cappucci.

Electrical panels «Sea» series

12V. - 5 A.
Capacity 10A.
Black colour panel.
Fuses 6,35 x 32 mm.
Supplied without caps.

| Articolo - Item | €/pc. | N. Interruttori Switches N. | ↕ mm. | Interruttori Switches | Portafusibili Fuses holder | kg. |
|-----------------|-------|--------------------------------|---------|--------------------------|-------------------------------|-------|
| L 06 16 360 | | 6 | 165x115 | L0608060 | L0610060 | 0,300 |
| L 06 09 100 | | 3 | 90x113 | L0608060 | L0610060 | 0,200 |



L0616360



L0609100



COMPLETO DI-COMLETE WITH



INTERRUTTORI SWITCHES (pag. 250)

PORTAFUSIBILI FUSES HOLDER (pag. 250)

Pannello elettrico in alluminio anodizzato nero

Piastra in lega leggera anodizzata nera provvista di 3 fori per utenze future.
Provvisto di spie luminose.

Electrical panel in black anodised aluminium

Plate in black anodised light alloy with 3 holes for future users.
With warning light.

| Articolo - Item | €/pc. | Mod. | ↕ mm. | Interruttori Switches | kg. |
|-----------------|-------|---|---------|--------------------------|-------|
| L 06 19 130 | | 5 Interruttori-Switches +3 (vuoti-empty) | 190x130 | L0605081 L0615081 | 0,650 |



L0619130

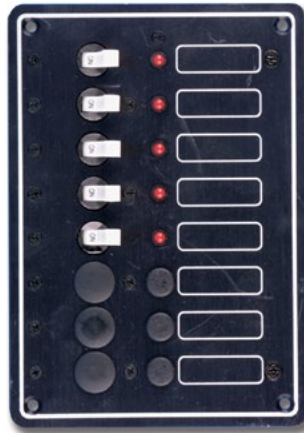

COMPLETO DI-COMLETE WITH



Art. L0605081 (pag. 251)

Pannelli di comando colore nero con indicatori al led

Realizzati in Abs, con indicatori al led. Funzionamento a 12V., resistenti all'acqua.

Electrical panel with led black colour

Manufactured in Abs. Waterproof model. 12V.

| Articolo - Item | €/pc. | N. Interruttori Switches N. | ↕ mm. | Interruttori Switches | Tappo in gomma Rubber caps | kg. |
|-----------------|-------|--------------------------------|--------|--------------------------|-------------------------------|-------|
| L 06 12 054 | | 4 | 98x98 | L0644002 | L0611000 | 0,230 |
| L 06 12 056 | | 6 | 98x152 | L0644002 | L0611000 | 0,400 |



L0612054



L0612056



COMPLETO DI-COMLETE WITH



INTERRUTTORI SWITCHES (pag. 250)

TAPPI IN GOMMA RUBBER CAPS (pag. 251)

VISIT OUR B2B AREA

- CREATE A CUSTOMER ACCOUNT
- CHECK AVAILABILITY & QUANTITY OF ITEMS
- CHECK YOUR COMMERCIAL CONDITION
- PLACE YOUR ORDER
- TRACK YOUR ORDER STATUS
- TRACK YOUR PAYMENT PROCESS

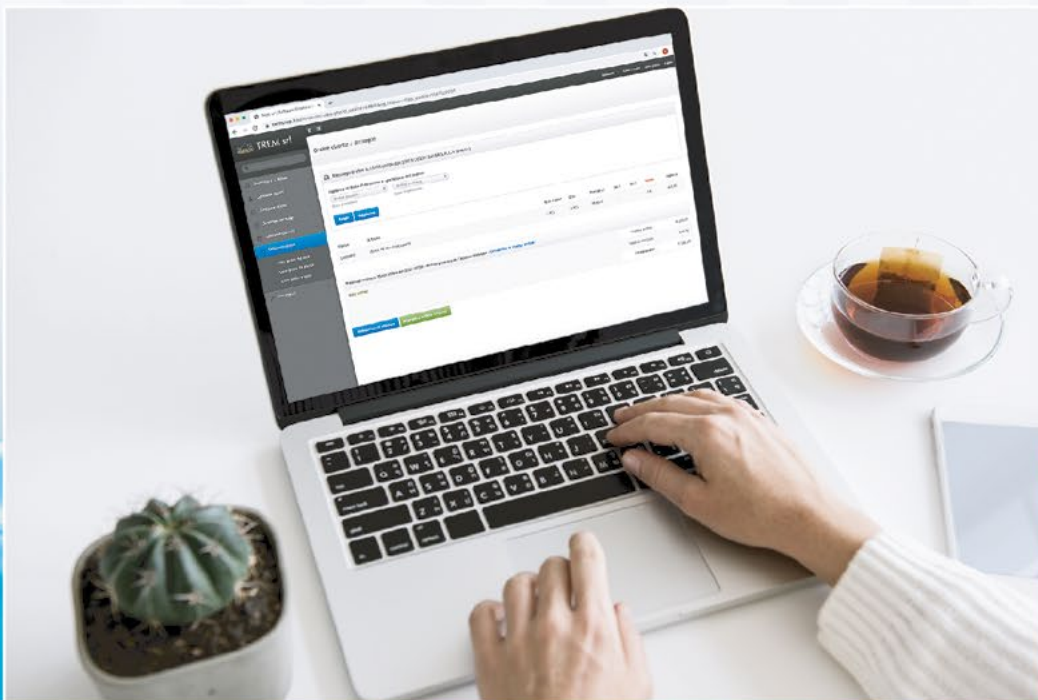

WWW.TREM.NET



RICAMBI PER PANNELLI ELETTRICI | SPARE PARTS FOR SWITCH PANELS

Interruttore-Switch ON-OFF 3P, 12V, 16A

Articolo - Item €/pc.
L 06 00 001



Interruttore Switch

Articolo - Item €/pc.
L 06 80 116



NEW



Interruttore Switch

Articolo - Item €/pc.
L 06 08 025



Interruttore-Switch ON-OFF 3P, 12V, 16A

Articolo - Item €/pc.
L 06 01 033



Interruttore-Switch ON-OFF-ON 4P, 12V, 16A

Articolo - Item €/pc.
L 06 32 003



NEW



Interruttore-Switch ON-OFF 3P, 12V, 16A

Articolo - Item €/pc.
L 06 32 004



NEW



Interruttore-Switch (ON)-OFF 2P, 12V, 16A

Articolo - Item €/pc.
L 06 32 005



NEW



Interruttore-Switch ON-OFF 6P, 12V(10A), 250V(6A)

Articolo - Item €/pc.
L 06 83 002



NEW



Interruttore-Switch ON-OFF 2PSQ

Articolo - Item €/pc.
L 06 08 060



Interruttore-Switch ON-OFF 2P, 12V(10A), 250V(6A)

Articolo - Item €/pc.
L 06 44 002



NEW



Interruttore Switch

Articolo - Item €/pc.
L 06 24 002



NEW



Portafusibili-Fuse holder 5A

Articolo - Item €/pc.
L 06 65 004



Portafusibili-Fuse holder 15A

Articolo - Item €/pc.
L 06 65 005



Portafusibili-Fuse holder 3A

Articolo - Item €/pc.
L 06 83 007



Portafusibili-Fuse holder 10A

Articolo - Item €/pc.
L 06 83 008



NEW



Portafusibili-Fuse holder 15A

Articolo - Item €/pc.
L 06 83 006



NEW



Portafusibili-Fuse holder 5A

Articolo - Item €/pc.
L 06 10 060



Portafusibili-Fuse holder 5A

Articolo - Item €/pc.
L 06 37 103



NEW



Portafusibili-Fuse holder 15A

Articolo - Item €/pc.
L 06 10 033



Portafusibili-Fuse holder 2P, Ø11 mm, 5A

Articolo - Item €/pc. Amp.
L 06 61 003 5



NEW VERTICAL ANGLE



**Portafusibili-Fuse holder
10A, 2P, Ø11 mm**

| Articolo - Item | €/pc. | Amp. |
|-----------------|-------|------|
| L 06 10 061 | | 10 |

1 VERTICAL ANGLE



**Portafusibili-Fuse holder
15A, 2P, Ø11 mm**

| Articolo - Item | €/pc. | Amp. |
|-----------------|-------|------|
| L 06 15 061 | | 15 |

1 VERTICAL ANGLE



**Portafusibili
Fuse holder**

| Articolo - Item | €/pc. | Amp. |
|-----------------|-------|------|
| L 06 61 103 | | 5 |

1 BENT ANGLE **NEW**



**Portafusibili
Fuse holder**

| Articolo - Item | €/pc. | Amp. |
|-----------------|-------|------|
| L 06 61 104 | | 10 |

1 BENT ANGLE **NEW**



**Portafusibili
Fuse holder**

| Articolo - Item | €/pc. | Amp. |
|-----------------|-------|------|
| L 06 61 105 | | 15 |

1 BENT ANGLE **NEW**



**Portafusibili
Fuse holder**

| Articolo - Item | €/pc. |
|-----------------|-------|
| L 06 44 005 | |

1 **NEW**



**Portafusibili
Fuse holder**

| Articolo - Item | €/pc. |
|-----------------|-------|
| L 06 64 004 | |

1 **NEW**



**Cappuccio in gomma
Rubber cap Ø11 mm**

| Articolo - Item | €/pc. | €/Box 10pc |
|-----------------|-------|------------|
| L 06 36 007 | | |

10 **NEW**



**Cappuccio in gomma
Rubber cap Ø11 mm**

| Articolo - Item | €/pc. | €/Box 10pc |
|-----------------|-------|------------|
| L 06 18 060 | | |

10



**Cappuccio in gomma
Rubber cap Ø11 mm**

| Articolo - Item | €/pc. | €/Box 10pc |
|-----------------|-------|------------|
| L 06 11 000 | | |

10



**Cappuccio in gomma
Rubber cap Ø11 mm**

| Articolo - Item | €/pc. | €/Box 10pc |
|-----------------|-------|------------|
| L 06 20 000 | | |

10 **NEW**



**Cappuccio in gomma
Rubber cap Ø11 mm**

| Articolo - Item | €/pc. | €/Box 10pc |
|-----------------|-------|------------|
| L 06 61 006 | | |

10 **NEW**



Interruttore a levetta

| Articolo - Item | €/pc. | Amp. |
|-----------------|-------|------|
| L 06 05 081 | | 5A. |
| L 06 10 081 | | 10A. |
| L 06 15 081 | | 15A. |
| L 06 20 082 | | 20A. |
| L 06 25 082 | | 25A. |
| L 06 30 082 | | 30A. |

1

Circuit breaker

| Ideale per-Ideal for | kg. |
|----------------------|-------|
| L0619130 | 0,050 |
| L0619130 | 0,050 |
| L0619130 | 0,050 |
| L0619130 | 0,050 |
| L0619130 | 0,050 |
| L0619130 | 0,050 |



**Serie 20 simboli lenticolari
adesivi utenze elettriche**

Serie di 20 simboli adesivi con superficie plastificata lenticolare.

| Articolo - Item | €/Serie 20 Simboli Series 20 Symbols |
|-----------------|---|
| D 15 00 020 | |

1

Self-adhesive code of electrical signals for boats

Set of 20 signals. White printing on black background.

| Simbolo-Symbol mm. | kg. |
|--------------------|-----|
| 15x20 | |



Interruttori a levetta a due e tre posizioni

Fabbricati in plastica ed ottone.
Capacità 15A./ora a 12V.

Push pull switch

Manufactured in plastic and brass. Capacity
15A./hour 12V.

| Articolo - Item | €/pc. | Mod. | Foro-Hole Ø mm. | kg. |
|-----------------|-------|-----------|--------------------|-------|
| L 06 08 055 | | ON-OFF | 12 | 0,010 |
| L 06 09 055 | | ON-OFF-ON | 12 | 0,010 |

**Interruttore con chiave di avviamento a tenuta stagna**

Completa di cappuccio in gomma a tenuta
stagna, 15A., a 3 posizioni.

Waterproof starter switch

With rubber cup, 15A.
3 position.

| Articolo - Item | €/pc. | Materiale Material | Terminali Terminals | kg. |
|-----------------|-------|-----------------------|------------------------|-------|
| L 06 10 270 | | Ottone-Brass | 3 | 0,160 |
| L 06 10 274 | | Ottone-Brass | 4 | 0,170 |
| L 06 10 271 | | Plastica-Plastic | 3 | 0,110 |
| L 06 10 272 | | Plastica-Plastic | 5 | 0,110 |

**Interruttore a tiretto**

Fabbricato in ottone cromato.
Carico massimo 10A.
Contatti argentati.
Massima funzionalità.

Push pull switch

Manufactured in chromed brass.
Maximum load 10A.
Silver contacts.
High efficiency.

| Articolo - Item | €/pc. | Mod. | Per paratia spessore Panel thickness mm. | kg. |
|-----------------|-------|-------------|---|-------|
| L 06 08 005 | | Corto-Short | 5 | 0,020 |
| L 06 08 020 | | Lungo-Long | 20 | 0,030 |

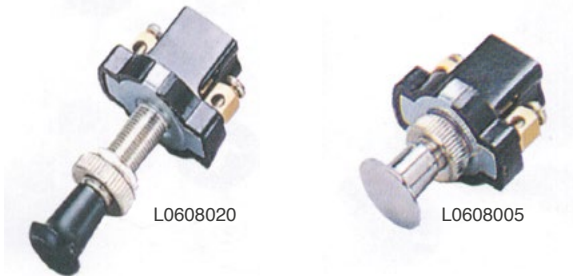
**Interruttore a tiretto modello con collo lungo**

Carico massimo 20A.
Fabbricato in ottone cromato.
Contatti argentati.

Push pull switch

Manufactured in chromed brass.
Maximum load 20A.
Silver contacts.

| Articolo - Item | €/pc. | Mod. | Filetto-Thread Ø mm. | Per paratia spessore Panel thickness mm. | kg. |
|-----------------|-------|--------------|-------------------------|---|-------|
| L 06 10 030 | | 2 poli-poles | 10 | 25 | 0,050 |

**Interruttore a levetta a due posizioni completo di cappuccio stagno in gomma**

Fabbricato in ottone.
Funzionamento 12V.
Modello a 2 poli.

Waterproof circuit breaker 2 positions with watertight rubber cap

Manufactured in brass.
Operating with 12V.
2 poles model.

| Articolo - Item | €/pc. | Ø mm. | Capacità-Capacity | Mod. | kg. |
|-----------------|-------|-------|------------------------|-------------|-------|
| L 06 12 000 | | 11 | 10A.- 250V./15A.-125V. | Int. ON-OFF | 0,020 |

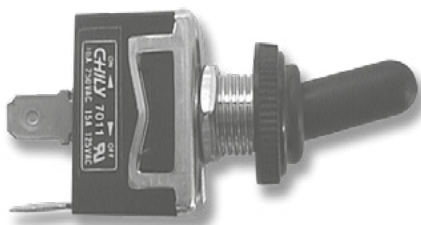
**Pulsante per trombe elettriche mod. «Stagno»**

Fabbricato in ottone.
Funzionamento 12V.
Modello a 2 poli.

Water proof horn switch

Manufactured in brass.
Operating with 12V.
2 poles model.

| Articolo - Item | €/pc. | Mod. | Filetto-Thread Ø mm. | Per paratia spessore Panel thickness mm. | Capacità Capacity |
|-----------------|-------|---------------------------|-------------------------|---|----------------------|
| L 06 16 020 | | Capp. gomma Rubber cap | 16 | 20 | 20A. |
| L 06 10 028 | | - | 16 | 20 | 20A. |



INTERRUTTORI E PULSANTI | SWITCHES & BUTTONS

Interruttore luminoso rosso 12V. Red switch 12V.

Adatto per frigo trivalente.

Suitable for refrigerator.

| Articolo - Item | €/pc. | kg. |
|-----------------|-------|-------|
| Z 20 00 237 | | 0,010 |

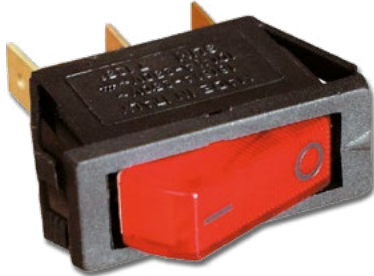

Pulsante IP65 con LED IP65 switch with LED

| Articolo - Item | €/pc. | Posizioni Positions | Pins | Colore Colour | Volts | Amp. | kg. |
|-----------------|-------|---------------------|------|---------------|-------|------|-------|
| L 06 01 119 | | 3 ON-OFF | 3 | ■ | 12 | 20 | 0,020 |



SPIE LUMINOSE | INDICATOR LIGHTS

Spia luminosa a LED 12-24V. LED indicator light 12-24V.

| Articolo - Item | €/pc. | €/Box 10pc | Ø mm. | Filo-Cable L mm. | Colore LED LED Colour | kg. |
|-----------------|-------|------------|-------|------------------|-----------------------|-----|
| L 06 12 030 | | | 5 | 300 | Rosso-Red | |



Spia luminosa a LED 220V. LED indicator light 220V.

| Articolo - Item | €/pc. | €/Box 10pc | Ø mm. | Filo-Cable L mm. | Colore LED LED Colour | kg. |
|-----------------|-------|------------|-------|------------------|-----------------------|-----|
| L 06 22 030 | | | 5 | 300 | Rosso-Red | |



INTERRUTTORI MAGNETOTERMICI | HIGH-AMP CIRCUIT BREAKERS

Interruttore magnetotermico da incasso quadrato

- Tensione: 42 VDC Maximum
- Interrupt rating: 3000A. @ 30 VDC
- Temperatura d'esercizio: -32°C to 82°C
- Temperatura magazzino: -34°C to 149°C
- Scatola: Thermoset plastic, UL rated 94VO
- IP67

High-Amp square recess circuit breaker

- Voltage: 42 VDC Maximum
- Interrupt rating: 3000A. @ 30 VDC
- Operating Temperature: -32°C to 82°C
- Storage Temperature: -34°C to 149°C
- Housing: Thermoset plastic, UL rated 94VO
- IP67

| Articolo - Item | €/pc. | Amp. | mm. |
|-----------------|------------|------|-------|
| L 06 15 615 | | 150 | 74x49 |
| L 06 05 615 | NEW | 50 | 74x49 |
| L 06 08 615 | NEW | 80 | 74x49 |
| L 06 10 615 | NEW | 100 | 74x49 |



INTERRUTTORI A BASCULA | TOGGLE SWITCHES

Interruttori a bascula impermeabili

Modello fabbricato in policarbonato, per l'installazione viene richiesto un foro rettangolare da mm. 21,5 x 36,8. Provvisto di doppio led sul pulsante per avere una doppia illuminazione diversificata nella parte ON e nella parte OFF (che rimane accesa in OFF e si illumina un'altra spia in ON).
Confezione da 20 pezzi senza bascula.

Waterproof toggle switches

Made in polycarbonate.
To install, cut a rectangular hole of 21,5x36,8 mm.
To light the symbol label, always switched on and to light a special slot under the symbol when it's switched on.
Packing: 20 pcs. without toggle.

| Articolo - Item | €/pc. | Funzionamento Working | Range | kg. |
|-----------------|-------|--|---|-------|
| L 07 02 002 | | ON - OFF 2 terminali - S/Led | ON - OFF Terminals | 0,020 |
| L 07 02 102 | | ON - OFF C/1 Led e 2 terminali | ON - OFF with 1 LED 2 Terminals | 0,030 |
| L 07 03 002 | | ON - OFF - MAN con ritorno 1 molla su OFF (per trombe comando WC) 3 terminali - C/1 Led | ON-OFF-MAN Switch, spring back ON-OFF (for electric toilets, horns etc) 2 terminals | 0,030 |
| L 07 03 006 | | ON - OFF - ON Bipolare con ritorno a molla al centro (per pass. idrauliche, trim, salpancore, flap) 6 terminali (attacchi) - S/Led | ON-OFF-ONtwo lines, spring back on the middle (for flaps, hydraulic gangways, anchor winches, etc.) 6 terminals | 0,030 |
| L 07 03 004 | | ON - OFF - ON ideale per 2 circuiti separati (pompe di sentina da manuale in automatico, due tipi di luci di via) 4 terminali - C/2 Led | ON-OFF-ON switch for two separate circuits (bilgepumps manual- auto, navigation lights) 4 terminals | 0,030 |
| L 07 03 104 | | ON - OFF - ON ideale per 2 circuiti separati momentanei, visto che ha il ritorno a molla al centro, (salpancore, passerella) 4 terminali - C/2 Led | ON-OFF-ON Switch, spring back on the middle (for two separate and momentary circuits (hydraulic gangways, anchor winches etc) 4 terminals | 0,030 |
| L 07 00 000 | | Attrezzo per smontare gli interruttori | Tool | 0,040 |



L0700058 L0701058 L0702058 L0703058

Cornici componibili in policarbonato

Ideali per formare un pannello con all'interno i pulsanti sopra indicati.

Polycarbonate frames

To build a single panel.

| Articolo - Item | €/pc. | €/Box 10 pc. | Per inserimento For fitting | kg. |
|-----------------|-------|--------------|-----------------------------|-------|
| L 07 00 058 | | | Centrale-Center | 0,120 |
| L 07 01 058 | | | Dx. / Sx.-Right/Left | 0,130 |
| L 07 02 058 | | | Centrale singolo-Single | 0,124 |
| L 07 03 058 | | | Tappo-Cap | 0,035 |

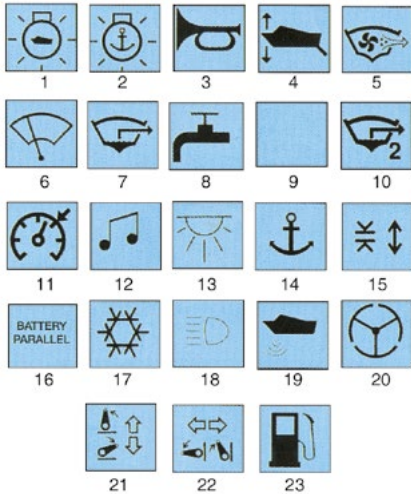

Basculi per pulsanti interruttori

Superficie antiscivolo. Fabbricate in policarbonato nero.

Actuator for switches

Non-slip surface. Made of black polycarbonate.

| Articolo - Item | Mod. | Articolo - Item | Mod. | Articolo - Item | Mod. | €/pc. | €/Box 6pc | kg. |
|-----------------|------|-----------------|------|-----------------|------|-------|-----------|-------|
| L 07 01 080 | 1 | L 07 09 080 | 9 | L 07 17 080 | 17 | | | 0,036 |
| L 07 02 080 | 2 | L 07 10 080 | 10 | L 07 18 080 | 18 | | | 0,036 |
| L 07 03 080 | 3 | L 07 11 080 | 11 | L 07 19 080 | 19 | | | 0,036 |
| L 07 04 080 | 4 | L 07 12 080 | 12 | L 07 20 080 | 20 | | | 0,036 |
| L 07 05 080 | 5 | L 07 13 080 | 13 | L 07 21 080 | 21 | | | 0,036 |
| L 07 06 080 | 6 | L 07 14 080 | 14 | L 07 22 080 | 22 | | | 0,036 |
| L 07 07 080 | 7 | L 07 15 080 | 15 | L 07 23 080 | 23 | | | 0,036 |
| L 07 08 080 | 8 | L 07 16 080 | 16 | - | - | | | 0,036 |



- | | | |
|---------------------------------|---------------------------------------|----------------------------------|
| 1 Luci di via-Navigation lights | 9 Neutro-No signs | 17 Frigo - Refrigerator |
| 2 Luci fonda-Anchorage lights | 10 2° pompa sentina-Bilge pump | 18 Faro profondità - Depth light |
| 3 Tromba-Horn | 11 Luci quadro-Panel lights | 19 Ecoscandaglio - Echo sounder |
| 4 Flap | 12 Stereo | 20 Pilota automatico - Autopilot |
| 5 Aspiratore-Suction blower | 13 Luci pozzetto cabina-Cabin lights | 21 Passerella - Gangway up&down |
| 6 Tergivetro-Wiper | 14 Comando verricelli-Winch | 22 Passerella - Gangway |
| 7 Pompa di sentina-Bilge pump | 15 Apertura portelloni - Door opening | 23 Carburante - Fuel |
| 8 Autoclave-Pressure tank | 16 Parallelo batterie - Batteries | |



Adesivi con 25 utenze per interruttori a bascula

Ideali per essere applicati sulle bascule sopraindicate.

Self-adhesive code for toggle switches

Set of 25 signals.

| Articolo - Item | €/Cartella-Set | kg. |
|-----------------|----------------|-------|
| L 07 00 025 | | 0,010 |



Simbologia tasti neri per corpo interruttore «Carling Contura»

Realizzati in materiale plastico stagno grado di protezione IP68.

Symbols of black keys for switches «Carling Contura»

Manufactured in waterproof IP68 plastic material.



| Articolo - Item | €/pc. | €/Box 10 pc. | Mod. | kg. |
|-----------------|-------|--------------|--------|-----|
| L 07 80 022 | | | NEUTRO | |



Solo corpo interruttore con 1 led colore rosso

I tasti neri con o senza simbolo vanno ordinati a parte.
Terminali in ottone argentato F 6,3.
Resistenti alle vibrazioni e ai raggi ultravioletti.
Temperatura di esercizio: -40°C / +85°C.
Foro di montaggio 36,83 x 21,08 mm.
Consumo Led 18mA.

Switch body with 1 red led

Fixing hole: 36,83 x 21,08 mm.
Led consumption: 18mA.
Working temperature: -40°C / +85°C.
Silver brass terminals F 6,3.
UV rays resistant.

| Articolo - Item | €/pc. | Contatto elettrico | Tensione utilizzo | Posizione interruttore | Numero contatti | Carico max Max load | Tasto nero (gomma 1 sola finestra) | Colore LED LED colour | LED | kg. |
|-----------------|-------|--------------------|-------------------|------------------------|-----------------|---------------------|------------------------------------|-----------------------|-----|-----|
| L 07 12 008 | | *Instabile | 12V. | *ON-OFF-*ON | Unipolare | 20A. | a richiesta on demand | Rosso-Red | 1 | |
| L 07 12 002 | | *Instabile | 12V. | OFF-*ON | Unipolare | 20A. | a richiesta on demand | Rosso-Red | 1 | |
| L 07 12 001 | | Stabile | 12V. | OFF-ON | Unipolare | 20A. | a richiesta on demand | Rosso-Red | 1 | |



Cornici per interruttori «Carling Contura»

Spessore pannello di montaggio da 0,76 a 4,76 mm.

Frames for switches «Carling Contura»

Thickness of mounting panel: 0,76 - 4,76 mm.

| Articolo - Item | €/pc. | €/Box | Mod. | Esterne-Outer | Interne-Inner | pcs. | kg. |
|-----------------|-------|-------|-----------------------------------|---------------|---------------|------|-----|
| L 07 21 001 | | | Sinistra/Destra Left/Right | 58x29 | 37x21 | 30 | |
| L 07 21 002 | | | Cornice centrale Central frame | 58x29 | 37x21 | 40 | |



Interruttori

Interruttori per quadri stagni. Forniti senza cappuccio L0700078.
Fabbricati in ottone nichelato.
10A. 250V. AC, 15A. 125V. AC e 15A. 12V. DC.

Toggle switches

Switches for mounting on waterproof panels. Supplied without cap L0700078.
UV resistant material resists discoloration and cracking. Made of Nickel-plated brass. 10A. 250V. AC, 15A. 125V. AC e 15A. 12V. DC.

| Articolo - Item | €/pc. | €/Box 10 pc. | Mod. | Funzione Function | Tipo Type | Denominazione Name | Term. | Contatti Contacts | Incasto Hole Ø mm. | Spessore pannello Panel thickness mm. | kg. |
|-----------------|-------|--------------|-------|-------------------|------------|-----------------------------|-------|-------------------|--------------------|---------------------------------------|-------|
| L 07 02 078 | | | 4150B | OFF - ON | Stabile | Interruttore | 2 | Faston | 9,65 | 1- 11 | 0,500 |
| L 07 06 078 | | | 4151B | OFF - *ON | *Instabile | Interruttore | 2 | Faston | 9,65 | 1- 11 | 0,500 |
| L 07 12 078 | | | 4152B | ON - OFF - ON | Stabile | Commutatore | 3 | Faston | 9,65 | 1- 11 | 0,500 |
| L 07 16 078 | | | 4154B | *ON - OFF - *ON | *Instabile | Commutatore | 3 | Faston | 9,65 | 1- 11 | 0,500 |
| L 07 18 078 | | | 4155B | ON - OFF - ON | Stabile | Commutatore | 6 | Faston | 9,65 | 1- 11 | 0,500 |
| L 07 00 078 | | | | | | Leva in gomma - Rubber knob | | | | | 0,200 |



Disgiuntori speciali termici unipolari «ETA»

Montaggio su boccola filettata, aggancio e pressione e sgancio a tirare.

Single pole high performance thermal circuit breaker «ETA»

With tease-free, trip-free, snap action mechanism and push/pull on/off manual actuation (M-type TO CBE to EN 60934). An indicator band on the push button clearly shows the tripped/off position.

| Articolo - Item | €/pc. | Mod. | Tensione Voltage | Amp. | mm. | kg. |
|-----------------|-------|---------|--|------|------------|-----|
| L 05 50 413 | | 413 | 28V. DC | 50A. | 49x32x18,5 | |
| L 05 70 413 | | 413 | 28V. DC | 70A. | 49x32x18,5 | |
| L 05 80 413 | | 413 | 28V. DC | 80A. | 49x32x18,5 | |
| L 05 00 413 | | 413/452 | Cappuccio di protezione - Protection cap | | | |



Disgiuntori a bascula impermeabili doppio LED giallo «ETA»

Impermeabili IP56, richiedono per l'installazione un foro rettangolare da 21,5x36,8 mm. Completati di 2 LED che segnalano l'attivazione dell'interruttore.

| Interruttore senza bascula 12V No toggle switch 12V | €/pc. | Volts | Amp. | Versione Version | Tipo Type | Bascula non inclusa Toggle not included | Uso Use | Terminali Terminals |
|--|-------|-------|------|---------------------|--------------|--|---|------------------------|
| L 05 12 003 | | 12 | 5 | Unipolare-Unipolar | ON-OFF | * | Generic | 3 |
| L 05 12 008 | | 12 | 8 | Unipolare-Unipolar | ON-OFF | * | Generic | 3 |
| L 05 12 010 | | 12 | 10 | Unipolare-Unipolar | ON-OFF | * | Generic | 3 |
| L 05 12 016 | | 12 | 16 | Unipolare-Unipolar | ON-OFF | * | Generic | 3 |
| L 05 12 020 | | 12 | 20 | Unipolare-Unipolar | ON-OFF | * | Generic | 3 |
| L 05 10 012 | | 12 | 10 | Unipolare-Unipolar | ON-OFF | * | Tromba-Comando WC Horn-WC Control | 3 |
| L 05 20 012 | | 12 | 20 | Unipolare-Unipolar | ON-OFF-ON | * | Passerelle idrauliche, Flap, Scale elettriche, Tettucci elettrici, Verricello Hydraulic gangways, Flaps, Electric ladders, Winches | 4 |
| L 05 04 012 | | 12 | 20 | Unipolare-Unipolar | ON-OFF-ON | * | Pompe sentina Bilge pumps | 4 |

Waterproof toggle switches double yellow LED «ETA»

IP56 watertight. 21.5x36.8-mm rectangular bore required for installation. Complete with 2 LED that switch on when the symbol indicator is activated.

NEW * Bascula non inclusa-Toggle not included



Bascula nera doppia finestra neutra «ETA» **Black toggle switch «ETA»**

| Articolo - Item | €/pc. | €/box 10 pc. | kg. |
|-----------------|-------|--------------|-----|
| L 05 12 031 | | | |

NEW



Cornici componibili «ETA» **«ETA» Frames**

| Articolo - Item | €/pc. | €/box 10 pc. | Modulo-Modulo | kg. |
|-----------------|-------|--------------|------------------|-----|
| L 05 79 101 | | | Centrale-Central | |
| L 05 79 001 | | | Laterale-Lateral | |

NEW

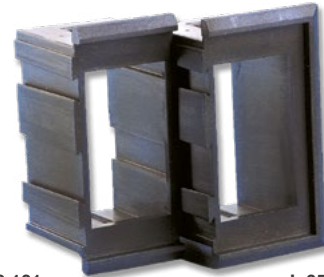

L 05 79 101

L 05 79 001

Interruttore a leva magnetoidraulico unipolare con fusibile automatico ricaricabile «ETA»

Studiati per uso marino. L'interruttore stacca istantaneamente, in caso di forte sovraccarico (esempio:corto circuito) mentre per sovraccarichi fino al 50% resta inserito per alcuni secondi affinché se questo è connesso ad un evento occasionale, abbia il tempo di rientrare nei limiti senza interrompere la corrente. In caso di corto circuito, l'interruttore non può essere reinseribile se non viene eliminato il problema.

Single pole circuit breaker with «ETA» rechargeable automatic fuse

Designed on purpose for the marine environment. In case of heavy overload (i.e.: short circuits), the circuit breaker disconnects instantaneously; for overloads up to 50% it maintains the contact for few seconds so, in case it is due to a chance event, it has time to return within the limits without interrupting the power supply. In case of short circuit, the switch cannot be reactivated until the problem is solved.

| Articolo - Item | €/pc. | Alimentazione universale Universal power supply | Capacità Capacity A |
|-----------------|-------|--|------------------------|
| L 05 41 005 | | DC/AC 12/220V | 5 |
| L 05 41 010 | | DC/AC 12/220V | 10 |
| L 05 41 016 | | DC/AC 12/220V | 16 |
| L 05 41 020 | | DC/AC 12/220V | 20 |
| L 05 41 030 | | DC/AC 12/220V | 30 |
| L 05 41 050 | | DC/AC 12/220V | 50 |

12-220V **NEW**

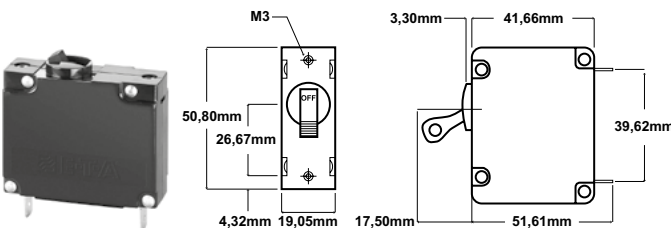

Interruttore magnetoidraulico bipolare per corrente alternata «ETA»

Da utilizzare nei servizi di bordo a 220V.

Dual pole AC circuit breaker «ETA»

For 220V onboard applications.

| Articolo - Item | €/pc. | Alimentazione universale Universal power supply | Capacità Capacity A |
|-----------------|-------|--|------------------------|
| L 05 42 020 | | DC/AC 12/220V | 20 |
| L 05 42 030 | | DC/AC 12/220V | 30 |
| L 05 42 050 | | DC/AC 12/220V | 50 |

12-220V **NEW**

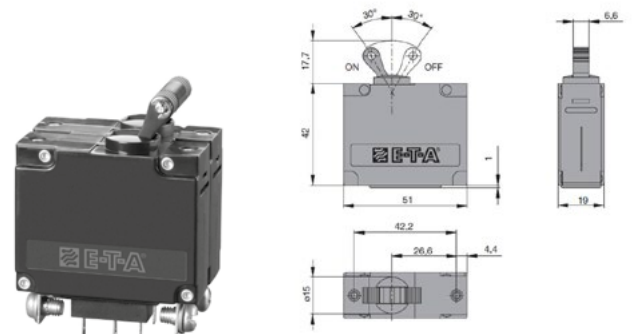

Interruttore in acciaio inox 7A

Portata 7A 12V.
IP67.
Corona luminosa durata 20.000 cicli.

Stainless steel switch 7A

7A 12V.
IP67.
Duration 20.000 cycles.

| Articolo - Item | €/pc. | Colore Colour | Mod. | Volts | Amp. |
|-----------------|-------|------------------|----------|-------|------|
| L 06 12 082 | | Rosso-Red | OFF-(ON) | 12 | 7 |
| L 06 12 075 | | Blu-Blue | OFF-(ON) | 12 | 7 |
| L 06 19 082 | | Rosso-Red | OFF-ON | 12 | 7 |
| L 06 19 075 | | Blu-Blue | OFF-ON | 12 | 7 |

12V AISI 316

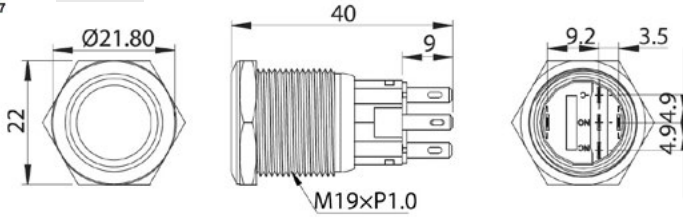

Interruttore in acciaio inox 20A

Carcassa in acciaio inox Aisi 316 e polimero.
Portata 20A 9-32V.
IP67
Durata 20.000 cicli.

Stainless steel switch 20A

Housing manufactured in Aisi 316 stainless steel with polymer.
20A 9-32V. IP67.
Duration 20.000 cycles.

| Articolo - Item | €/pc. | Colore Colour | Mod. | Volts | Amp. |
|-----------------|-------|------------------|-----------------------|-------|------|
| L 06 75 020 | | Blu-Blue | ON-OFF | 9-32 | 20 |
| L 06 82 020 | | Rosso-Red | ON-OFF | 9-32 | 20 |
| L 06 75 120 | | Blu-Blue | (ON)-OFF (momentaneo) | 9-32 | 20 |
| L 06 82 120 | | Rosso-Red | (ON)-OFF (momentaneo) | 9-32 | 20 |

12V AISI 316 NEW

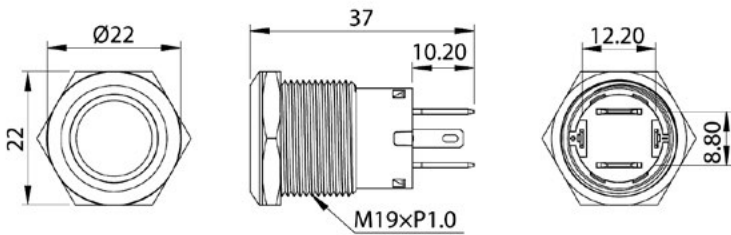

Interruttore in acciaio inox 15A

Carcassa in acciaio inox Aisi 316.
Portata 15A 9-32V.
IP67
Durata 20.000 cicli.

Stainless steel switch 15A

Housing manufactured in Aisi 316 stainless steel.
15A 9-32V.
IP67.
Duration 20.000 cycles.

| Articolo - Item | €/pc. | Colore Colour | Mod. | Volts | Amp. |
|-----------------|-------|------------------|-----------------------|-------|------|
| L 06 74 063 | | Blu-Blue | ON-OFF | 9-32 | 15 |
| L 06 82 063 | | Rosso-Red | ON-OFF | 9-32 | 15 |
| L 06 74 163 | | Blu-Blue | (ON)-OFF (momentaneo) | 9-32 | 15 |
| L 06 82 163 | | Rosso-Red | (ON)-OFF (momentaneo) | 9-32 | 15 |

12V AISI 316 NEW

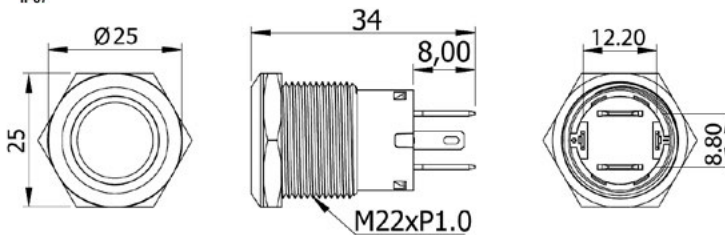

Serie simboli 24 adesivi «3M»

Kit 24 labels «3M»

| Articolo - Item | €/serie 24 simboli-labels | €/Box 2 serie |
|-----------------|---------------------------|---------------|
| L 07 00 024 | | |

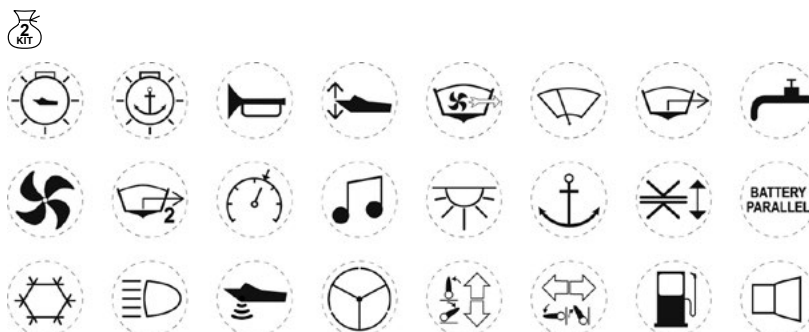

Presa 12V. auto (tipo accedisigari)

Socket 12V. for car (cigarette lighter)

| Articolo - Item | €/pc. | Colore Colour | kg. |
|-----------------|-------|---------------|-----|
| Z 20 79 120 | | Grigio-Grey | |
| Z 20 86 120 | | Marrone-Brown | |
| Z 20 74 120 | | Bianco-White | |



Presa 12V. standard

Socket 12V. standard

| Articolo - Item | €/pc. | Colore Colour | kg. |
|-----------------|-------|---------------|-----|
| Z 20 79 012 | | Grigio-Grey | |
| Z 20 74 012 | | Bianco-White | |



Presa 12V. auto (tipo accedisigari) con coperchio stagno

Socket 12V. for car (cigarette lighter) w/waterproof cover

| Articolo - Item | €/pc. | Colore Colour | kg. |
|-----------------|-------|---------------|-----|
| Z 20 12 286 | | Marrone-Brown | |



Presa 12V. auto (tipo accedisigari) con coperchio

Socket 12V. for car (cigarette lighter) w/cover

| Articolo - Item | €/pc. | Colore Colour | kg. |
|-----------------|-------|---------------|-----|
| Z 20 79 121 | | Grigio-Grey | |
| Z 20 86 121 | | Marrone-Brown | |
| Z 20 74 121 | | Bianco-White | |



Presa TV (TV 9,5 75 Ohm)

TV socket (TV 9,5 75 Ohm)

| Articolo - Item | €/pc. | Colore Colour | kg. |
|-----------------|-------|---------------|-----|
| Z 20 86 095 | | Marrone-Brown | |
| Z 20 74 095 | | Bianco-White | |



Presa 12V. standard + TV + SAT (TV 9,5 75 Ohm)

Socket 12V. standard + TV + SAT (TV 9,5 75 Ohm)

| Articolo - Item | €/pc. | Colore Colour | kg. |
|-----------------|-------|---------------|-----|
| Z 20 75 086 | | Marrone-Brown | |
| Z 20 75 074 | | Bianco-White | |



Presa TV + SAT (TV 9,5 75 Ohm SAT F 75 Ohm)

TV + SAT socket (TV 9,5 75 Ohm SAT F 75 Ohm)

| Articolo - Item | €/pc. | Colore Colour | kg. |
|-----------------|-------|---------------|-----|
| Z 20 86 275 | | Marrone-Brown | |
| Z 20 74 275 | | Bianco-White | |



Presa 12V. + TV (TV 9,5 75 Ohm)

Socket 12V. + TV (TV 9,5 75 Ohm)

| Articolo - Item | €/pc. | Colore Colour | kg. |
|-----------------|-------|---------------|-----|
| Z 20 95 079 | | Grigio-Grey | |
| Z 20 95 086 | | Marrone-Brown | |
| Z 20 95 074 | | Bianco-White | |



Presa 230V. italiana con coperchio e scatola di protezione

Socket 230V. with cover and protection box

| Articolo - Item | €/pc. | Colore Colour | kg. |
|-----------------|-------|---------------|-----|
| Z 20 86 230 | | Marrone-Brown | |
| Z 20 74 230 | | Bianco-White | |



Interruttore unipolare **Unipolar switch**

| Articolo - Item | €/pc. | Colore Colour | kg. |
|-----------------|-------|---------------|-----|
| Z 20 20 079 | | Grigio-Grey | |
| Z 20 20 086 | | Marrone-Brown | |
| Z 20 20 074 | | Bianco-White | |



Interruttore 12V. + LED **Switch 12V. + LED**

| Articolo - Item | €/pc. | Colore Colour | kg. |
|-----------------|-------|---------------|-----|
| Z 20 24 086 | | Marrone-Brown | |
| Z 20 24 074 | | Bianco-White | |

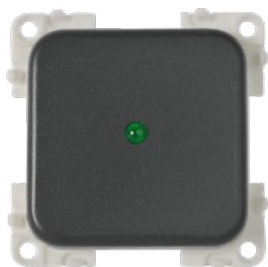

Deviatore unipolare **Two ways switch**

| Articolo - Item | €/pc. | Colore Colour | kg. |
|-----------------|-------|---------------|-----|
| Z 20 21 086 | | Marrone-Brown | |
| Z 20 21 074 | | Bianco-White | |



Interruttore unipolare doppio **Double unipolar switch**

| Articolo - Item | €/pc. | Colore Colour | kg. |
|-----------------|-------|---------------|-----|
| Z 20 23 074 | | Bianco-White | |

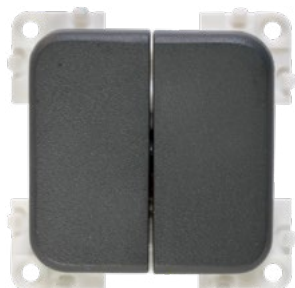

Interruttore gradino a 3 posizioni **Switch 3 positions**

| Articolo - Item | €/pc. | Colore Colour | kg. |
|-----------------|-------|---------------|-----|
| Z 20 27 086 | | Marrone-Brown | |
| Z 20 27 074 | | Bianco-White | |



Variatore elettronico luci e ventole 12V.-3A. **Electronic dimmer 12V. - 3A.**

| Articolo - Item | €/pc. | Colore Colour | kg. |
|-----------------|-------|---------------|-----|
| Z 20 30 074 | | Bianco-White | |



Interruttore 12V. + LED **Switch 12V. + LED**

| Articolo - Item | €/pc. | Colore Colour | kg. |
|-----------------|-------|---------------|-----|
| Z 20 25 079 | | Grigio-Grey | |
| Z 20 25 086 | | Marrone-Brown | |



Interruttore 12V. doppio **Double switch 12V.**

| Articolo - Item | €/pc. | Colore Colour | kg. |
|-----------------|-------|---------------|-----|
| Z 20 26 086 | | Marrone-Brown | |
| Z 20 26 074 | | Bianco-White | |



Interruttore doppio pompa e luci **Switch pump & lights**

| Articolo - Item | €/pc. | Colore Colour | kg. |
|-----------------|-------|---------------|-----|
| Z 20 31 079 | | Grigio-Grey | |



SPINE, PRESE E INTERRUTTORI «CBE» | PLUGS, SOCKETS & SWITCHES «CBE»

Modulo 4 Fusibili 4 Fuses module

| Articolo - Item | €/pc. | Colore Colour | kg. |
|-----------------|-------|------------------|-----|
| Z 20 33 079 | | Grigio-Grey | |

Distanziale per
montaggio interruttore
a parete 60x60x10 mm. Spacer for wall
mounting
60x60x10 mm.

| Articolo - Item | €/pc. | Colore Colour | kg. |
|-----------------|-------|------------------|-----|
| Z 20 34 079 | | Grigio-Grey | |
| Z 20 34 074 | | Bianco-White | |

Cornice 1 modulo
60x60x10 mm. Frame 1 module
60x60x10 mm.

| Articolo - Item | €/pc. | Colore Colour | kg. |
|-----------------|-------|------------------|-----|
| Z 20 79 060 | | Grigio-Grey | |
| Z 20 86 060 | | Marrone-Brown | |
| Z 20 74 060 | | Bianco-White | |

Cornice 2 moduli
113x60x10 mm. Frame 2 modules
113x60x10 mm.

| Articolo - Item | €/pc. | Colore Colour | kg. |
|-----------------|-------|------------------|-----|
| Z 20 74 113 | | Bianco-White | |

Cornice CBE 1 modulo
86x78x10 mm. Frame CBE 1 module
86x78x10 mm.

| Articolo - Item | €/pc. | Colore Colour | kg. |
|-----------------|-------|------------------|-----|
| Z 20 79 086 | | Grigio-Grey | |
| Z 20 86 086 | | Marrone-Brown | |
| Z 20 74 086 | | Bianco-White | |

Cornice CBE
2 moduli 78x140 mm. Frame CBE 2 mo-
dules 78x140 mm.

| Articolo - Item | €/pc. | Colore Colour | kg. |
|-----------------|-------|------------------|-----|
| Z 20 86 160 | | Marrone-Brown | |
| Z 20 74 160 | | Bianco-White | |

Presse 12V. auto + TV
(TV 9,5 75 Ohm)

| Articolo - Item | €/pc. | Colore Colour | kg. |
|-----------------|-------|------------------|-----|
| Z 20 79 075 | | Grigio-Grey | |
| Z 20 74 075 | | Bianco-White | |







Socket 12V. car + TV
(TV 9,5 75 Ohm)Presse 230V. «Schuko» standard
tedesca con coperchio completa
di scatola di protezione

| Articolo - Item | €/pc. | Colore Colour | kg. |
|-----------------|-------|------------------|-----|
| Z 20 22 079 | | Grigio-Grey | |
| Z 20 22 086 | | Marrone-Brown | |
| Z 20 22 074 | | Bianco-White | |

Socket 230V. 230V. «Schuko»
with cover complete with
protection box

Fusibili lamellari e portafusibili

Fuses and fuses holder

| Articolo - Item | €/pc. | €/Box | Mod. | Colore Colour |  |  kg. |
|-----------------|-------|-------|------|---|---|---|
| L 06 05 519 | | | 5A. |  | 10 | 0,130 |
| L 06 10 519 | | | 10A. |  | 10 | 0,130 |
| L 06 15 519 | | | 15A. |  | 10 | 0,130 |
| L 06 20 519 | | | 20A. |  | 10 | 0,130 |
| L 06 30 519 | | | 30A. |  | 10 | 0,130 |



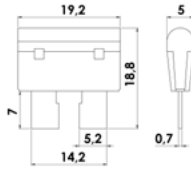

STANDARD FUSE

SUGGESTED ITEMS



Fusibili «Mini»

Fuses «Mini»

| Articolo - Item | €/pc. | €/Box | Mod. | mm. |  |  kg. |
|-----------------|-------|-------|------|--------|---|---|
| L 06 10 503 | | | 10A. | 11,2x4 | 10 | 0,050 |
| L 06 25 503 | | | 25A. | 11,2x4 | 10 | 0,050 |
| L 06 30 503 | | | 30A. | 11,2x4 | 10 | 0,050 |

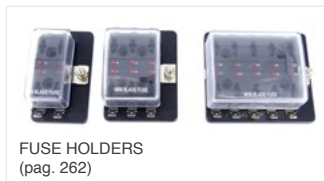

MINI FUSE LOW PROFILE

SUGGESTED ITEMS



Fusibili «Maxi»

Fuses «Maxi»

| Articolo - Item | €/pc. | €/Box | Mod. | mm. |  |  kg. |
|-----------------|-------|-------|------|------|---|---|
| L 06 50 505 | | | 50A. | 29x9 | 10 | 0,060 |
| L 06 60 505 | | | 60A. | 29x9 | 10 | 0,060 |
| L 06 70 505 | | | 70A. | 29x9 | 10 | 0,060 |

MAXI FUSE



Fusibile «ANL»

Capacità: da 35A a 100A.
Tensione 32VDC massima.

Fuse «ANL»

Ratings: 35A-100A.
Voltage: 32VDC max.

| Articolo - Item | €/pc. | Materiale Material | Capacità Capacity Amp. |  kg. |
|-----------------|-------|-----------------------|---------------------------|---|
| L 06 03 618 | | Bakelite | 35 | 0,020 |

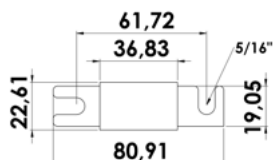



Scatola portafusibili lamellari standard in policarbonato con coperchio trasparente a scatto

Contatti bronzo fosforoso argentato. Accetta fusibili lamellari standard. Voltaggio ammesso 9/32V. Massimo amperaggio totale scatola 100A. Massimo amperaggio per ogni fusibile: 30A. La luce rossa indica la rottura del fusibile.

Fuse holder box with transparent snap cover manufactured in polycarbonate

Silver-plated phosphor bronze connections. It fit regular lamellar fuses. Admissible voltage: 9/32V. Total max amperage of the box 100A. Max amperage for each fuse 30 A. Red light indicates fuse failure.

| Articolo - Item | €/pc. | Sedi fusibili Fuse housing | Contatti Contacts (-) | (-) Comune Common | (+) Comune Common | ↑ mm. |
|-----------------|-------|-------------------------------|--------------------------|----------------------|----------------------|--------|
| L 06 06 606 | | 6 | 6 | 1 | 1 | 88x88 |
| L 06 12 612 | | 12 | 12 | 1 | 1 | 140x88 |

9-32V NEW

SUGGESTED ITEMS



Scatola portafusibili lamellari standard con positivo comune

Fabbricata in policarbonato, con contatti in rame stagnato. Coperchio trasparente con etichette utenze. Carico massimo per ogni blocco 150A. Terminali a vite.

Standard blade fuse holder box with common positive

Made of polycarbonate with tinplated copper contacts. Transparent cover with labels for single uses. 150A max load for each block. Screw terminals.

| Articolo - Item | €/pc. | Sedi fusibili Fuse housing | Attacchi Fittings | Massa | ↑ mm. |
|-----------------|-------|-------------------------------|----------------------|--------|-------|
| L 06 01 611 | | 6 | Faston | Si-Yes | 92x66 |
| L 06 02 611 | | 6 | A vite-Screw | Si-Yes | 92x66 |
| L 06 01 613 | | 10 | Faston | Si-Yes | 92x99 |
| L 06 02 613 | | 10 | A vite-Screw | Si-Yes | 92x99 |

9-32V NEW

SUGGESTED ITEMS

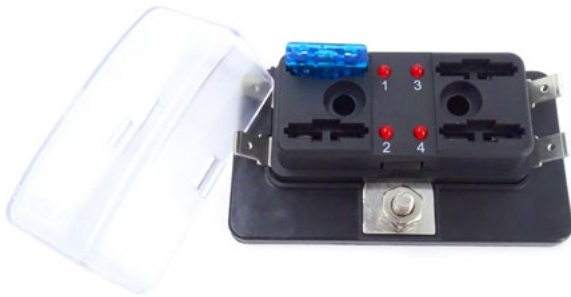

Scatola portafusibili standard lamellari con spie d'allarme a LED

Riceve fusibili lamellari standard. Completa di LED di allarme fusibile interrotto.

Fuse holder box with LED warning light

For standard lamellar fuses. Equipped with LED warning light for cut off fuse.

| Articolo - Item | €/pc. | Sedi fusibili Fuse housing | LED allarme Alarm LED | Capacità Capacity max A. | A mm. | B mm. | C mm. | D mm. |
|-----------------|-------|-------------------------------|--------------------------|-----------------------------|-------|-------|-------|-------|
| Z 20 04 514 | | 4 | 4 | 100 | 47 | 85 | 36 | 63 |
| Z 20 06 514 | | 6 | 6 | 100 | 63 | 85 | 36 | 63 |
| Z 20 11 514 | | 10 | 10 | 100 | 95 | 85 | 36 | 63 |

NEW

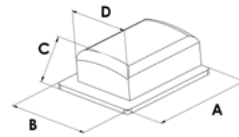

SUGGESTED ITEMS



Scatola portafusibili Mini lamellari con spie d'allarme a LED

Ingresso: 100A. Uscita: 30A.

Fuse holder box with LED warning light

IN: 100A. OUT: 30A.

| Articolo - Item | €/pc. | Sedi fusibili Fuse housing | LED allarme Alarm LED | Capacità Capacity max A. | A mm. | B mm. | C mm. | D mm. |
|-----------------|-------|-------------------------------|--------------------------|-----------------------------|-------|-------|-------|-------|
| Z 20 04 513 | | 4 | 4 | 100 | 47 | 85 | 36 | 63 |
| Z 20 06 513 | | 6 | 6 | 100 | 63 | 85 | 36 | 63 |

NEW

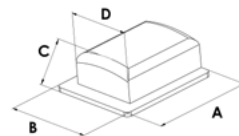

SUGGESTED ITEMS



Portafusibile stagno IP66

Per fusibili lamellari standard ATO-ATC. Portata max 20A.

| Articolo - Item | €/pc. |
|-----------------|-------|
| L 06 11 517 | |



Waterproof fuse holder IP66

For standard lamellar fuses ATO-ATC. Max capacity 20A.

Portafusibile stagno IP66

Di alta qualità in termogomma per fusibili lamellari standard ATO-ATC. Completo di 2 cavetti da 260 mm. sezione 4 mm². Portata max 30A.

| Articolo - Item | €/pc. |
|-----------------|-------|
| Z 20 10 511 | |



Waterproof fuse holder IP66

High quality thermo rubber for standard lamellar fuses ATO-ATC. With 2 cables 260 mm. section 4 mm². Max capacity 30A.

Portafusibile stagno IP66 con LED d'allarme

Di alta qualità, per fusibili lamellari standard ATO-ATC. Completo di 2 cavetti da 110 mm. sezione 3 mm².

| Articolo - Item | €/pc. |
|-----------------|-------|
| L 06 02 110 | |

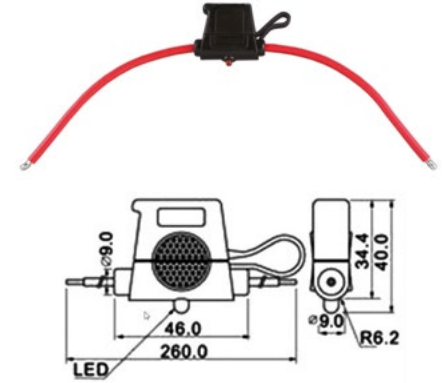

Portafusibile «CBE»

+ 1 Fusibile a piastrina. Completo di capocorda.

| Articolo - Item | €/pc. |
|-----------------|-------|
| Z 20 00 450 | |



Fuse holder «CBE»

+ 1 Fuse. Complete with terminal.



**MORSETTIERE E PORTA TERMINALI
CONNECTOR BOXES & TERMINAL BOARDS**

Scatola di derivazione elettrica stagna

Watertight electrical shunt boxes

| Articolo - Item | €/pc. | Materiale Material | Ingressi Input | Morsetti Clamps | mm. |
|-----------------|-------|-----------------------------|---|-----------------|-----------|
| L 06 08 044 | | Plastica nera Black plastic | 3 (2 medi, 1 piccolo) 3 (2 medium, 1 small) | 8 (4+4) | 76x127x45 |



Morsettiera per impianti elettrici

Fabbricata in bachelite.

| Articolo - Item | €/pc. |
|-----------------|-------|
| L 06 08 152 | |

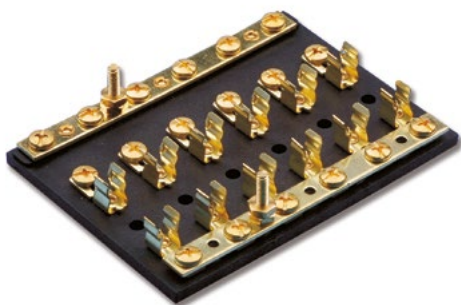

Waterproof connectors box

Manufactured in Bakelite.

| N. Contatti Contacts | Base mm. |
|----------------------|----------|
| 8 | 83x150 |

Terminazione cavi elettrici in bakelite ad alto isolamento

Con morsetti terminali in ottone nichelato. Separatori per evitare contatti accidentali.

| Articolo - Item | €/pc. | Terminali Terminals | Amp. |
|-----------------|-------|---------------------|------|
| L 06 04 020 | | 4 | 20 |



High-insulated terminal board made of Bakelite

Fitted with nickel plated brass terminal clamps. Separators to avoid accidental contacts.

Porta terminali elettrici Bus-Bar

Base plastica ad alta capacità isolante. Barra di supporto in rame nichelato, viti e dadi in acciaio inox. Volt 12/48.

| Articolo - Item | €/pc. | Terminali Derivazione mm. | Terminali Potenza mm. | Base mm. |
|-----------------|-------|---------------------------|-----------------------|----------|
| L 06 10 582 | | 10x4 | 2x6 | 145x31 |
| L 06 20 582 | | 20x4 | 2x6 | 225x31 |



Bus-Bar electric terminal board

High insulating capacity plastic base; nickel-plated copper support bar, stainless steel screws and nuts. Volt 12/48.



Tergicristallo «TMC»

Contenitore a tenuta stagna, alberino 50 mm. Angolo regolabile da 83°-100°-110°-120°, due velocità, ritorno automatico. 12V. Amp. alta velocità 1,5A. Amp. bassa velocità 1,0A.

Windscreen wiper «TMC»

Waterproof case, shaft 50 mm. Adjustable angle 83°-100°-110°-120°, two speeds, 12V. High speed amp. 1,5A. Low speed Amp. 1,0A.

| Articolo - Item | €/pc. | Volts | Mod. |
|-----------------|-------|-------|-------------------------------|
| L 07 00 906 | | 12 | B - Alberino lungo-Long shaft |

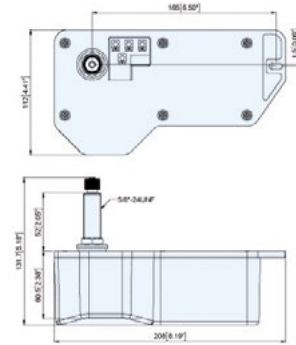

SUGGESTED ITEM



Art. L0709508
(pag. 266)

Art. L0740016
L0740018
(pag. 266)



Tergicristallo ad attacco rapido

Fabbricato con materiali antiruggine, corpo verniciato a fuoco in colore nero. L'angolo di rotazione della spazzola può essere regolato su ampiezza di 83°-100°-110°-120°. Alberino 50 mm. Ø 16 mm. Per paratie di spessore da 3 mm. a 38 mm. Assorbimento 1,5A fast speed a 12V, 1A low speed a 12V.

Windscreen wiper quick connection

Manufactured in antirust material, black painted housing. Adjustable angle 83°-100°-110°-120°. Shaft 50 mm. Ø 16 mm. Suitable for bulkhead from 3 mm. to 38 mm. thickness. 12V. High speed amp. 1,5A. Low speed Amp. 1,0A.

| Articolo - Item | €/pc. | Volts |
|-----------------|-------|-------|
| L 07 00 902 | | 12 |

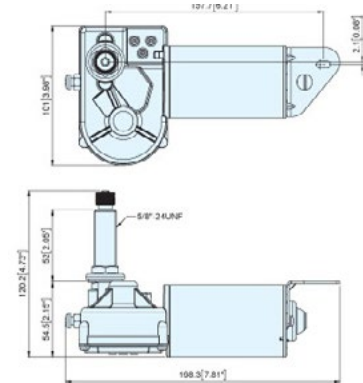

SUGGESTED ITEM



Art. L0709508
L0714272
(pag. 266)

Art. L0740016
L0740018
(pag. 266)



Tergicristallo fissaggio a vite

Fabbricato con materiali antiruggine, corpo verniciato a fuoco in colore nero. L'angolo di rotazione della spazzola può essere regolato su ampiezza di 83°-100°-110°-120°. Alberino 50 mm. Ø 16 mm. Per paratie di spessore da 3 mm. a 38 mm. Assorbimento 1,5A fast speed a 12V, 1A low speed a 12V.

Windscreen wiper

Manufactured in antirust material, black painted housing. Adjustable angle 83°-100°-110°-120°. Shaft 50 mm. Ø 16 mm. Suitable for bulkhead from 3 mm. to 38 mm. thickness. 12V. High speed amp. 1,5A. Low speed Amp. 1,0A.

| Articolo - Item | €/pc. | Volts |
|-----------------|-------|-------|
| L 07 91 101 | | 12 |

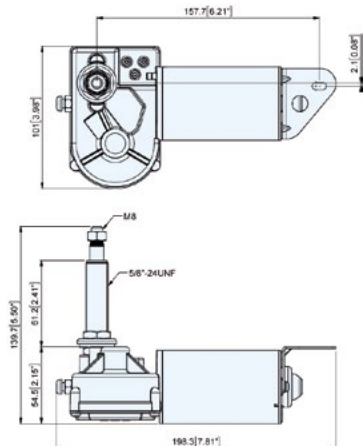

SUGGESTED ITEM



Art. L0727010
L0733047
(pag. 266)

Art. L0740016
L0740018
(pag. 266)

Tergicristalli a ritorno automatico

Custodia rivestita in PVC.
Angolo di battuta 90°.
● Amperaggio: 1A (12V.)
● Fusibile: 1,5A (12V.)

Self-parking windscreen wiper

PVC coating housing.
Sweeping angle 90°.
● Amp draw: 1A (12V.)
● Fuse: 1,5A (12V.)

| Articolo - Item | €/pc. | Volts | kg. |
|-----------------|-------|-------|-------|
| L 07 31 011 | | 12 | 0,850 |



SUGGESTED ITEM



Art. L0725007 (pag. 266) Art. L0728014 L0719015 (pag. 266)

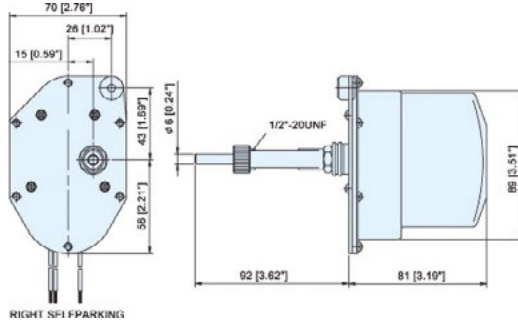

Tergicristalli

Carenato inox, torna sempre al punto di partenza.
Angolo di regolazione 110°. Filettatura Ø 9 mm.
Perno Ø 6 mm. Lunghezza totale 55 mm. Lunghezza perno 15 mm. Da completare con Art. L0725007-L0728014-L0719015.
Alimentazione 12V. 1A.

Windscreen wiper

Stainless steel housing, self-parking. Angle 110°.
Threading Ø 9 mm. Shaft Ø 6 mm. Shaft length 55 mm. 12V. 1A.

| Articolo - Item | €/pc. | Mod. | kg. |
|-----------------|-------|------------|-------|
| L 07 00 802 | | 12V - 110° | 0,680 |



SUGGESTED ITEM



Art. L0725007 (pag. 266) Art. L0728014 L0719015 (pag. 266)

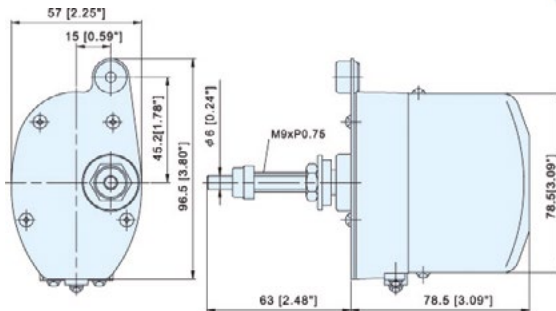

Tergicristalli

Carcassa stagna, torna sempre al punto di partenza.
Angolo di regolazione 110°. Filettatura Ø 9 mm.
Perno Ø 6 mm. Lunghezza perno 15 mm. Completo di braccio telescopico da 190-280 mm. (L0725007) e spazzola in acciaio inox 280 mm. (L0728014).
Alimentazione 12V.

Windscreen wiper

Waterproof housing. Self-parking. Angle 110°.
Threading Ø 9 mm. Shaft Ø 6 mm. Shaft length 55 mm. 12V. 1A.

| Articolo - Item | €/pc. | Mod. | kg. |
|-----------------|-------|------------|-------|
| L 07 15 255 | | 12V - 110° | 1,000 |



COMPLETE WITH

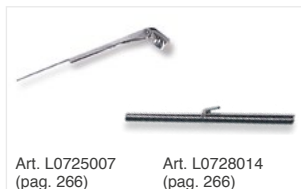

Art. L0725007 (pag. 266) Art. L0728014 (pag. 266)

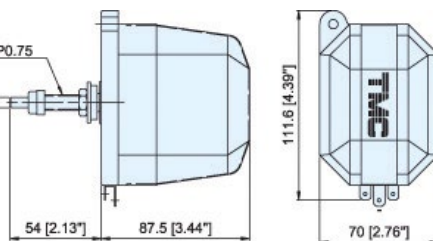

SUGGESTED ITEM

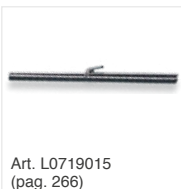

Art. L0719015 (pag. 266)



TERGICRISTALLI | WINDSCREEN WIPERS

Braccio

Realizzato in acciaio verniciato nero regolabile da 240 mm. a 320 mm. Sollevabile per la pulizia del parabrezza. Per Art. L0700905-L0700906-L0700902. Fissaggio rapido.

| Articolo - Item | €/pc. | Lunghezza-Length mm. |
|-----------------|-------|----------------------|
| L 07 09 508 | | 240-320 |

**Wiper arm**

Manufactured in black painted steel. Adjustable from 240 mm. to 320 mm. Suitable for Art. L0700905-L0700906-L0700902. Quick connection.

Spazzola

Per tergicristalli in acciaio inox ideali per vetri piani (per Art. L0709508-L0714272).

| Articolo - Item | €/pc. | Lunghezza-Length mm. |
|-----------------|-------|----------------------|
| L 07 40 018 | | 400 |

**Wiper blade**

Suitable for stainless steel windscreen wiper for flat surface (for Art. L0709508-L0714272).

Braccio a pantografo

Realizzato in acciaio inox. Regolabile. Per Art. L0700902. Attacco rapido.

| Articolo - Item | €/pc. | Lunghezza-Length mm. |
|-----------------|-------|----------------------|
| L 07 14 272 | | 280-380 |

**SUGGESTED ITEM**

Art. L0701312
(pag. 266)

**Parallel wiper arm**

Manufactured in stainless steel. Adjustable. For Art. L0700902. Quick connection.

Spazzola

Realizzata in plastica, per tergicristalli (per Art. L0709508-L0714272).

| Articolo - Item | €/pc. | Lunghezza-Length mm. |
|-----------------|-------|----------------------|
| L 07 40 016 | | 400 |

**Wiper blade**

Manufactured in plastic. Suitable for Art. L0709508-L0714272.

Attacco per montaggio bracci accoppiati

| Articolo - Item | €/pc. | kg. |
|-----------------|-------|-------|
| L 07 01 312 | | 0,160 |

**Bracket for parallel wiper arms****Braccio di ricambio**

Per Art. L0731011-L0700802-L0715255.

| Articolo - Item | €/pc. | Lunghezza-Length mm. |
|-----------------|-------|----------------------|
| L 07 25 007 | | 190-280 |

**Spare wiper arm**

For Art. L0731011-L0700802-L0715255.

Spazzola di ricambio

Per Art. L0731011-L0700802-L0715255.

| Articolo - Item | €/pc. | Lunghezza-Length mm. |
|-----------------|-------|----------------------|
| L 07 28 014 | | 280 |
| L 07 19 015 | | 355 |

**Spare wiper blade**

For Art. L0731011-L0700802-L0715255.

Braccio fissaggio a vite

Per tergicristalli in acciaio inox Aisi 316. Sollevabile per la pulizia del parabrezza (per Art. L0791101). Fissaggio a vite.

| Articolo - Item | €/pc. | Lunghezza-Length mm. |
|-----------------|-------|----------------------|
| L 07 27 010 | | 280-380 |
| L 07 33 047 | | 340-430 |

**Wiper arm screw connection**

For Aisi 316 stainless steel windscreen wipers. For Art. L0791101.

Centralina elettronica per tergicristalli

Adatto per tergicristalli heavy duty pag. 286 e 289.
 Funzionamento a 12V. e 24V.

- Consumo max 4A. per motore
- Fusibile: 15A.
- Fino a 5 regolazioni
- Configurazione da 1-3 tergicristalli
- Pannello touch screen
- Interfaccia led
- Può essere acceso singolarmente o in ogni combinazione
- Tipologia di funzione indicata da 5 led
- Scatola relay con cavo plug-in

SPECIFICHE-SPECIFICATIONS

| Key position | Function | Description |
|--------------|------------------------|--|
| 1 | Power | ON/OFF LED ON - WIPER ON LED OFF - WIPER OFF |
| 2 | Wiper LED lamp | ON/OFF |
| 3 | Single wiper motor key | DECREASE TIME INTERVAL |
| 4 | Time key (go left) | INCREASE TIME INTERVAL |
| 5 | Time key (go right) | LED ON - TIME KEY ON - LED OFF - TIME KEY OFF |
| 6 | Time key LED lamp | |

| LED State | Time Interval | Operation Mode |
|-----------|-------------------------|----------------|
| +C | Low speed or Fast speed | Continuous |
| +5 | 5 seconds | Intermittent |
| +10 | 10 seconds | Intermittent |
| +15 | 15 seconds | Intermittent |
| +20 | 20 seconds | Intermittent |

Electronic wiper controller

Work with series heavy duty wiper motors page 286 and 289.
 Can be used with DC-12V and 24V system.

- Power consumption: max 4A. per wiper motor
- Fuse size: 15A.
- Range of 5 timing regulations
- From 1-3 wipers configuration
- Smart touch panel
- Led interface
- Can be switched on individually or in any combination
- Selected function mode visualized by 5 led lights
- Relay box with plug-in cable

SPECIFICHE-SPECIFICATIONS

Installazione:

- Foro di montaggio 58 x 58mm
- Fissare a parete spessore tra 6mm e 25mm.

Installation:

- Cut a square hole by size 58 x 58mm
- Fit for wall thickness between 6mm to 25mm.

| Articolo - Item | €/pc. | Mod. | kg. |
|-----------------|-------|--------------------------|-------|
| L 07 22 405 | | Centralina-wiper control | 0,260 |

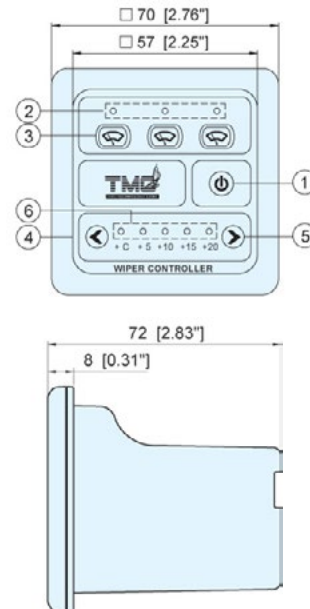

Tergicristalli manuale

Con impugnatura in ottone cromato. Completo di braccio in acciaio inox telescopico da 190 a 280 mm. e spazzola in acciaio inox, lunghezza 280 mm.

Manual windscreen wiper

Chromed brass handle. C omplete with stainless steel arm adjustable from 190 mm. to 280 mm. and stainless steel blade length 280 mm.

| Articolo - Item | €/pc. | Mod. | kg. |
|-----------------|-------|---------------------------|-------|
| L 07 00 033 | | Bracci-Wiper arms 280 mm. | 0,260 |



TROMBE E AVVISATORI ACUSTICI ELETTRICI | HORNS & ACOUSTIC ALARMS

Tromba a membrana aerodinamica Electric horn

Carcassa in ABS, linea compatta. ABS housing.

| Articolo - Item | €/pc. | Finitura Finishing | Volts | Amp. | Potenza Power dB | ↕ mm. | kg. |
|-----------------|-------|----------------------|-------|------|------------------|------------|-------|
| L 02 13 008 | | ABS bianco White ABS | 12 | 4,5 | 114 | 100x155x70 | 0,300 |

12V



Tromba a membrana Electric horn

In acciaio inox, con corni in acciaio inox. Fully manufactured in stainless steel.

| Articolo - Item | €/pc. | Mod. | Volts | ↕ mm. | kg. |
|-----------------|-------|----------------|-------|---------|-------|
| L 00 15 013 | | Singolo-Single | 12 | 395x100 | 0,650 |
| L 00 15 023 | | Doppio-Double | 12 | 455x190 | 1,250 |

12V AISI 316



Tromba a membrana alta potenza High power electric horn

Corpo in ABS cromato con supporto in acciaio inox lucidato a specchio. Chromed ABS housing with mirror polished stainless steel holder.

Potenza singola tromba 115 +/- 5dB. Horn power 115 +/- 5dB.

| Articolo - Item | €/pc. | Sonorità Sonority mt. | Tono Tone | Volts | Amp. |
|-----------------|-------|-----------------------|-------------------------------|-------|------|
| L 00 12 120 | | 950 | Bassa frequenza Low frequency | 12 | 8 |

12V

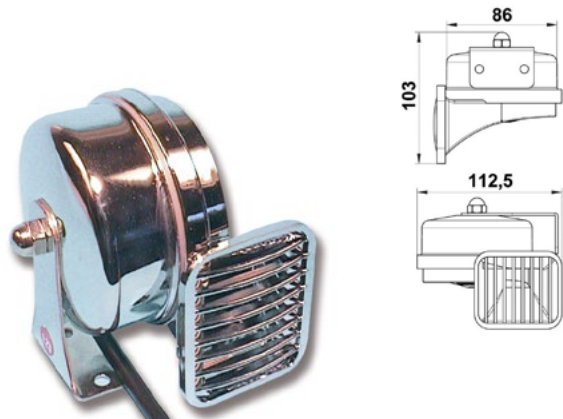

Tromba a membrana Electric horn

Corpo in acciaio inox lucidato a specchio, corno in ABS cromato. Mirror polished stainless steel housing, Chromed ABS horn.

| Articolo - Item | €/pc. | Mod. | Volts | Amp. | Potenza Power dB | L mm. | Corpo Body Ø mm. | kg. |
|-----------------|-------|-------------|-------|------|------------------|-------|------------------|-------|
| L 00 15 017 | | Corto-Short | 12 | 5 | 105 | 210 | 82,5 | 0,400 |
| L 00 15 018 | | Lungo-Long | 12 | 5 | 105 | 268 | 82,5 | 0,500 |

12V AISI 316

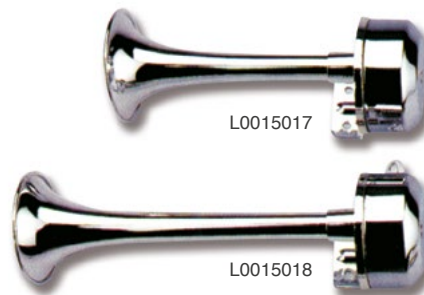

Tromba a membrana compatta Electric horn

Corpo in acciaio inox lucidato a specchio, base in ABS. Mirror polished stainless steel housing, ABS base.

Potenza singola tromba 115 +/- 5dB. Horn power 115 +/- 5dB.

| Articolo - Item | €/pc. | Volts | Amp. | ↕ mm. | kg. |
|-----------------|-------|-------|------|-------------|------|
| L 00 92 100 | | 12 | 4 | 110x100x80H | 0,31 |

12V AISI 316

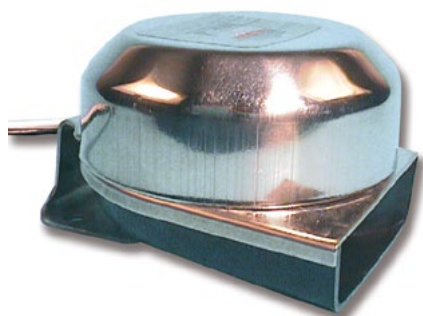

Megafono elettrico professionale Electric megaphone

Funzioni: Megafono + Sirena + Fischio

Functions: Megaphone + Siren + Whistle

| Articolo - Item | €/pc. | Portata | | L mm. | Bocca Ø mm. | Power | Autonomia | kg. |
|-----------------|-------|---------------|--------------|-------|-------------|-------------------------------|-----------|-------|
| | | Area urbana m | All'aperto m | | | | | |
| L 00 22 350 | | 30 | 350 | 1000 | 375 221 | 6 pile 1,5V Mezzatorcia (CM1) | 8h | 1,600 |



TROMBE E AVVISATORI ACUSTICI ELETTRICI | HORNS & ACOUSTIC ALARMS

Tromba da incasso a scomparsa con diffusore a chiocciola

Carcassa in ABS, mascherina bianca White 9003. La tromba a membrana con diffusore a chiocciola ha la particolarità di erogare un suono molto potente (nella scala acustica 130dB).

Recessed electric horn

ABS housing.
External White Ral 9003 ABS cover.
High power 130dB.
External installation.

| Articolo - Item | €/pc. | Volts | Amp. | Potenza Power dB | Incasso Recess mm. | kg. |
|-----------------|-------|-------|------|------------------|--------------------|-------|
| L 02 74 130 | | 12 | 8 | 130 | 96x60 | 0,300 |

1 12V made by 

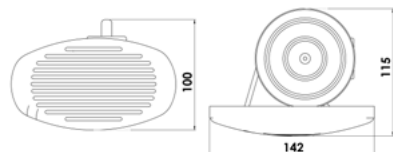

Tromba da incasso a scomparsa

Si monta abitualmente sul trincarino dello scafo e all'esterno appare solo la piccola mascherina in ABS bianco White 9003. Montaggio dall'esterno.

Recessed electric horn

External White Ral 9003 ABS cover.
External installation.

| Articolo - Item | €/pc. | Volts | Amp. | Potenza Power dB | Incasso Recess mm. | kg. |
|-----------------|-------|-------|------|------------------|--------------------|-------|
| L 02 00 108 | | 12 | 5 | 100 | 86x50x74 (Depth) | 0,180 |

1 12V made by 

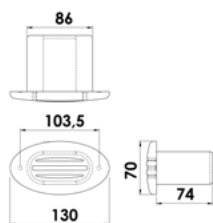

THE VOICE



Tromba da incasso a scomparsa

Carcassa in ABS.
Montaggio dall'esterno.

Recessed electric horn

ABS housing.
External installation.

| Articolo - Item | €/pc. | Volts | Amp. | Potenza Power dB | Colore Colour | kg. |
|-----------------|-------|-------|------|------------------|---------------|-------|
| L 02 12 105 | | 12 | 5 | 105 | White 9003 | 0,210 |
| L 02 33 105 | | 12 | 5 | 105 | VTR 9010 | 0,210 |

1 12V made by 

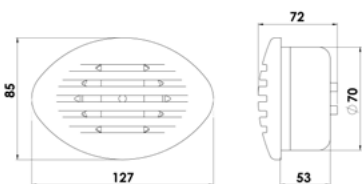

SUPER VOICE



Tromba da incasso a scomparsa

Tromba con carcassa e mascherina in acciaio inox Aisi 316.

Recessed electric horn

Aisi 316 stainless steel housing and cover.

| Articolo - Item | €/pc. | Volts | Amp. | Potenza Power dB | Impedenza Impedance | kg. |
|-----------------|-------|-------|------|------------------|---------------------|-------|
| L 06 06 102 | | 12 | 5 | 112 | 500Hz | 0,370 |

1 12V AISI 316 made by 

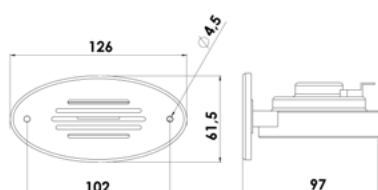

FRONTALINI STEREO | RADIO COVERS

Frontalino stereo con chiusura ermetica Flush mount radio cover

Fabbricato in ABS.
Resistente agli urti e ai raggi UV.
Modello impermeabile.

Manufactured in ABS, waterproof.
Shockproof.
UV-resistant.

| Articolo - Item | €/pc. | mm. | kg. |
|-----------------|-------|--------------|-------|
| L 46 60 727 | | 248x111,6x54 | 0,290 |



Plancia con chiusura ermetica a pulsante per autoradio Flush mount radio cover

Dotata di sportello in plexiglass apribile,
protegge la radio dall'acqua.

Opening door manufactured in plexiglass.
Waterproof.

| Articolo - Item | €/pc. | mm. | kg. |
|-----------------|-------|---------|-------|
| L 46 00 230 | | 230x110 | 0,260 |



STEREO NAUTICI E ALTOPARLANTI | SPEAKERS & ACCESSORIES

Antenna a Baffo

Caratteristiche tecniche:

- 320 x 35 x h 15 mm.
- Protezione al calore umidita freddo.
- Cavo 2 mt..

Waterproof antenna

Technical features:

- 320x35xh 15 mm.
- Protect from heating, cooler ,humidity
- Cavo 2 mt..

| Articolo - Item | €/pc. | Colore-Colour | kg. |
|-----------------|-------|---------------|-------|
| L 46 00 057 | | Bianco-White | 1,000 |



Cavo ingresso USB/AUX

Caratteristiche tecniche:

- Ideale per la connessione di ogni lettore MP3 o altro fonte audio esterna
- La porta USB è ideale per la connessione di chiavette USB o altri contenitori multimediali di musica

USB/AUX cable

Technical features:

- USB port allows connection of an external storage device
- 3.5 mm. AUX jack allows connection of any MP3 player or external audio device

| Articolo - Item | €/pc. | kg. |
|-----------------|-------|-------|
| L 46 00 071 | | 1,000 |



Casse doppio cono

Coppia casse in ABS bianco con cono interno in Pvc.
Impedenza 2 vie 8Ω.
Frequenza di risposta 65 ~ 22.000 Hz.

Pair of stereo speakers

Manufactured in white ABS. Internal cone in PVC.
Impedance 2 ways 8Ω.
Frequency 65 ~ 22.000 Hz.

| Articolo - Item | €/pair | Potenza Power | Frequenza Frequency Hz | A mm. | B mm. | D mm. | E mm. | Impedenza Impedance | kg. |
|-----------------|--------|---------------|------------------------|-------|-------|-------|-------|---------------------|-------|
| L 46 05 060 | | 80W. | 65 ~ 22.000 | 94 | 65 | 110 | 150 | 2 vie-ways 8Ω | 1,210 |
| L 46 06 070 | | 100W. | 65 ~ 22.000 | 117 | 75 | 130 | 185 | 2 vie-ways 8Ω | 1,960 |

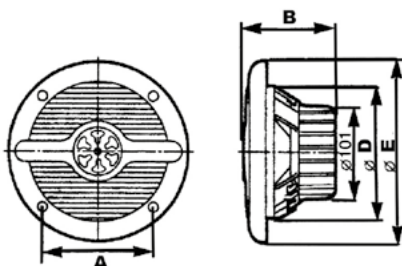

STEREO NAUTICI E ALTOPARLANTI | RADIO & SPEAKERS

Radio USB/Bluetooth

Caratteristiche tecniche:

- Waterproof (IP66)
- Display LCD alta visibilità
- Bluetooth
- Collegamento USB tramite cavo retrostante
- Uscita RCA ausiliare
- Display retroilluminato luce blu
- Lettore MP3
- Radio AM/FM
- 4x40 watts
- Buona protezione ai raggi UV

Radio USB/Bluetooth

Technical features:

- Waterproof (IP66)
- LCD high performance display
- Bluetooth function
- Digital media device connection via rear USB input
- Rear auxiliary RCA out
- Blue backlit
- MP3 player
- AM/FM radio
- 4x45 watts
- UV stable

| Articolo - Item | €/pc. | kg. |
|-----------------|-------|-------|
| L 46 00 820 | | 3,000 |

WATERPROOF

Bluetooth made by 

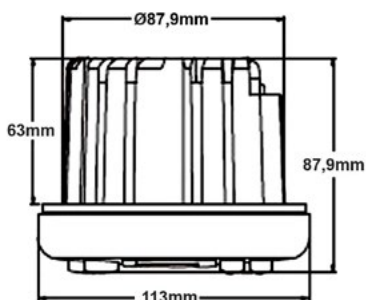

Radio USB/Bluetooth

Caratteristiche tecniche:

- Waterproof (IP66)
- Display LCD alta visibilità
- TELECOMANDO
- Bluetooth
- Collegamento USB tramite cavo retrostante
- Uscita RCA ausiliare
- Display retroilluminato luce blu
- Lettore MP3 waterproof
- Radio AM/FM
- 4x50 watts
- Buona protezione ai raggi UV

Radio USB/Bluetooth

Technical features:

- Waterproof (IP66)
- LCD high performance display
- REMOTE CONTROLLER
- Bluetooth function
- Digital media device connection via rear USB input
- Rear auxiliary RCA out
- Blue backlit
- MP3 player
- AM/FM radio
- 4x45 watts
- UV stable

| Articolo - Item | €/pc. | kg. |
|-----------------|-------|-------|
| L 46 00 045 | | 3,500 |

WATERPROOF

Bluetooth made by 
NEW

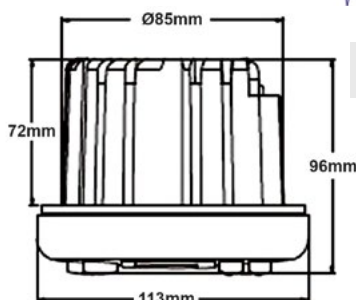

**PROVVISTA DI TELECOMANDO
WITH REMOTE CONTROLLER**



Copristero in PVC

Resistente ai raggi UV.

PVC radio cover

UV resistant.

| Articolo - Item | €/pc. | mm. (interne-inner) | mm. (esterne-outer) | kg. |
|-----------------|-------|---------------------|---------------------|-------|
| L 46 00 146 | | Ø146x27,5H | Ø114x25H | 0,300 |



NEW



Cassa speaker 6,5"

Caratteristiche tecniche:
 • Potenza max 50W.

| Articolo - Item | €/pc. | Mod. | kg. |
|-----------------|-------|-------|--------|
| L 46 00 650 | | MS650 | 14,000 |



Coaxial speaker 6,5"

Technical features:
 • Max power 50W.

| Articolo - Item | €/pc. | Mod. | kg. |
|-----------------|-------|-------|--------|
| L 46 00 650 | | MS650 | 14,000 |

Griglia

Grille

| Articolo - Item | €/pc. | Mod. | kg. |
|-----------------|-------|----------------------------------|-------|
| L 46 74 065 | | PMSX65GRW - White classic Grille | 1,000 |



Cavo ingresso ausiliare 1/8"

Caratteristiche tecniche:
 • Ideale per la connessione di ogni lettore MP3 o altro fonte audio esterna.

| Articolo - Item | €/pc. | Mod. | kg. |
|-----------------|-------|--------|-------|
| L 46 18 003 | | jPORTG | 1,000 |



1/8" Auxiliary Input Jack

Technical features:
 • Allows connection of any MP3 player or external audio device.

| Articolo - Item | €/pc. | Mod. | kg. |
|-----------------|-------|--------|-------|
| L 46 18 003 | | jPORTG | 1,000 |

Cavo connessione controlli remoti 18'

18' Extension Cable

| Articolo - Item | €/pc. | Mod. | kg. |
|-----------------|-------|--------|-------|
| L 46 18 002 | | JENAUX | 2,000 |

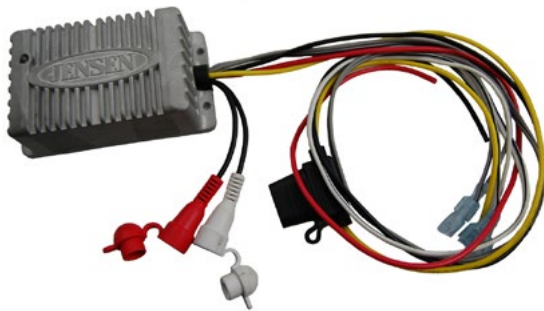

Amplificatore Bluetooth 2 canali

Caratteristiche tecniche:
 • Permette di connettere gli speakers tramite Bluetooth
 • Potenza massima 80 Watt (40 watts RMS)
 • Waterproof IPX6
 • Comando illuminato
 • 4 ohm - 8 ohm
 • Funzione 10-18V
 • Frequenza di risposta 20Hz - 20KHz
 • Resistente alla corrosione

2 Channel Bluetooth amplifier

Technical features:
 • Makes standard speakers Bluetooth-capable
 • 80 watts max (40 watts RMS)
 • Waterproof (IPX6)
 • Illuminated program button
 • 4 ohm - 8 ohm stable
 • Operating voltage: 10-18V
 • Frequency response: 20Hz - 20 KHz
 • Corrosion resistant finishes/materials (ASTM B117)

| Articolo - Item | €/pc. | Mod. | kg. |
|-----------------|-------|-----------|-------|
| L 46 02 240 | | JAHD240BT | 1,000 |



STEREO NAUTICI E ALTOPARLANTI | SPEAKERS & ACCESSORIES

Modello «Sunbay»

Caratteristiche tecniche:
 • Colore nero
 • Provvisto di pannello solare per batterie ricaricabili
 • Possibilità di regolare il volume via wireless
 • Anti urto
 • Sommersibile
 Confezione in scatola completa di postazione per MP3, cavo di alimentazione e cassa galleggiante.

| Articolo - Item | €/pc. | kg. |
|-----------------|-------|-------|
| L 46 74 180 | | 2,040 |



«Sunbay» model

Technical features:
 • Black colour
 • With solar panel for rechargeable batteries
 • Wireless volume regulation
 • Shockproof
 • Submersible

Packing in a box with MP3 docking, power cable and floating speaker.

Modello «Shark»

Caratteristiche tecniche:
 • Colore bianco
 • Funzionamento wireless
 • Provvisto di tastiera per cambiare frequenze stazioni e per regolare il volume
 • Anti urto
 • Sommersibile
 Confezione in scatola completa di postazione per MP3, cavo di alimentazione e cassa galleggiante.

| Articolo - Item | €/pc. | kg. |
|-----------------|-------|-------|
| L 46 74 160 | | 1,660 |



«Shark» model

Technical features:
 • White colour
 • Wireless
 • With keyboard for volume regulation
 • Shockproof
 • Submersible

Packing in a box with MP3 docking, power cable and floating speaker.

Stereo MGR350B

Stereo da cruscotto con design circolare. 240W di picco. Connessione Bluetooth per riprodurre i brani presenti sul tuo smartphone o MP3. Ingresso USB o AUX posti sul retro della radio, ma riportabili in console con un cavo accessorio opzionale (L4500071). Ghiera cromata sopra lo sfondo nero e retro-illuminazione blu. Ø esterno 92 mm. Sporgenza 20 mm. Foro incasso Ø 76 mm. Profondità 125 mm. 2 uscite preout RCA stereo. Resistente agli spruzzi.

Stereo MGR350B

Bluetooth Audio Streaming. Play and control music. Compatible with Audio out from Smart Phones and MP3 Players. USB/AUX input. Chromed ring and blue colour back light. External Ø 92 mm. Mounting hole Ø 76 mm. Depth 125 mm. 2 RCA preout. 240W.

| Articolo - Item | €/pc. | kg. |
|-----------------|-------|-----|
| L 46 03 493 | | |



SUGGESTED ITEM



Art. L4600071 (pag. 270)

Radio MR1308UAB

Radio senza lettore CD. Con tecnologia Bluetooth per ascoltare la musica del telefonino. Sintonizzatore AM/FM con RDS. Riproduzione di MP3. Potenza uscita 50Wx4 su 4 ohm. Ingresso USB e AUX-IN sul frontalino e SD card a 32GB dietro al frontalino. 1 uscita pre-out RCA stereo. Telecomando IR compreso. Frontalino estraibile resistente UV.

Radio MR1308UAB

Weather Proof 50 Watts x 4 Max Power. No CD or DVD Player, Plays MP3, WMA, FM/AM, Digital Media from Smart Phones and MP3 Players. USB, SD, Aux, Input. Front Pre Amp Outputs. Detachable Front Panel, Wireless Remote Bluetooth Hands Free. Play and control music.

| Articolo - Item | €/pc. | kg. |
|-----------------|-------|-----|
| L 46 01 308 | | |



Coppia altoparlanti stagni MR50

Realizzati in ABS bianco, coassiali a 2 vie. Risposta frequenza 120Hz-18Khz. Ø esterno 155 mm. Ø foro 123 mm. Profondità 54 mm.

Pair of weather proof speakers MR50

Manufactured in white ABS. Coaxial 2 ways. Frequency 120Hz-18Khz. Outer Ø 155 mm. Hole Ø 123 mm. Depth 54 mm.

| Articolo - Item | €/pair | Potenza Power | Impedenza Impedance Ohm | kg. |
|-----------------|--------|---------------|-------------------------|-----|
| L 46 02 050 | | 150W max | 4 | |



Coppia altoparlanti stagni MR6

Realizzati in ABS bianco, coassiali a 2 vie. Risposta frequenza 80Hz-20Khz. Ø esterno 196 mm. Ø foro 139 mm. Profondità 66 mm.

Pair of weather proof speakers MR6

Manufactured in white ABS. Coaxial 2 ways. Frequency 80Hz-20Khz. Outer Ø 196 mm. Hole Ø 139 mm. Depth 66 mm.

| Articolo - Item | €/pair | Potenza Power | Impedenza Impedance Ohm | kg. |
|-----------------|--------|---------------|-------------------------|-----|
| L 46 00 006 | | 180W | 4 | |



Coppia altoparlanti MR65G3 con 3 mascherine in dotazione

Pair of speakers MR65G3 with 3 front panels

| Articolo - Item | €/pair | Potenza Power | kg. |
|-----------------|--------|---------------|-----|
| L 46 00 653 | | 250W | |



Altoparlante stagno MRGB65

Dotato di un sofisticato sistema di luci a LED che consente innumerevoli varianti di giochi di luce. Fornito di un driver sincronizzatore in grado di guidare le luci di due altoparlanti. Regolazione intensità luminosa su 5 livelli. Risposta in frequenza da 70Hz a 20Khz. Ø esterno 197 mm. Ø foro 142 mm. Profondità 65 mm. Driver luci a 12VDC 90x50x23 mm.

Weather proof speaker MRGB65

Weather Proof Full Range 6.5" 2-Way Speaker Pair. 200 Watts MAX 100 Watts RMS Power Handling per Pair. 70 Hz to 20 kHz Frequency Response and 88dB Sensitivity. Polypropylene Woofer Cone and Treated Cloth Surround. 1 Tweeter Per Speaker. Multi Color LED Illumination, with Wireless Remote.

| Articolo - Item | €/pc. | Potenza Power | Impedenza Impedance Ohm | Ø esterno Outer mm. | kg. |
|-----------------|-------|---------------|-------------------------|---------------------|-----|
| L 46 74 659 | | 200W max | 4 | 197 | |





Phon 12V.

Dotato di cavo 2 mt. e spina accendisigari.

Hair dryer 12V.

With cigarette lighter plug. Cable length 200 cm.

| Articolo - Item | €/pc. | Potenza-Power Watt | Amp. | kg. |
|-----------------|-------|--------------------|------|-------|
| L 64 12 156 | | 156 | 9 | 0,300 |
| L 64 12 180 | | 180 | 9 | |



Saldatore 12V. con attacco accendisigari

Soldering gun with cigarette lighter plug

| Articolo - Item | €/pc. | Volts | kg. |
|-----------------|-------|-------|-------|
| L 06 12 502 | | 12 | 0,090 |



Macchina caffè

Presa accendisigari. 12V. 130W. 10A.

Coffee maker

With cigarette lighter plug. 12V. 130W. 10A.

| Articolo - Item | €/pc. | kg. |
|-----------------|-------|-------|
| L 64 02 490 | | 0,480 |



SUPPORTI A PARETE PER TV | TV WALL SUPPORT

Supporto a parete TV

Realizzati in alluminio. Per schermi da 13" a 30".

Wall support for TV

Suitable for displays from 13" up to 30". Manufactured in aluminium.

| Articolo - Item | €/pc. | Tipo -Type | Portata Kg. Capacity Kg. | mm. | Braccio-Arm L mm. | kg. |
|-----------------|-------|-------------------|--------------------------|------------|-------------------|-------|
| H 10 03 396 | | 3 snodi-junctions | 8 | 116x152x81 | 390 | 1,250 |



Strumenti e sensori per la tua navigazione

TREM è un' ampia gamma di strumenti di grande precisione per monitorare la navigazione garantendo una qualità eccelsa, nata dalla sinergia e una stretta collaborazione tra TR.EM., forte delle sue conoscenze nel settore Marine e un'affermata azienda produttrice di strumenti da tempo presente nel settore Automotive.

Design - Gamma - Facilità d'installazione - Qualità Packaging

Tutte le scale e amperaggi oggi richiesti sono disponibili per incasso nelle stesse dimensioni standard da sempre presenti (Ø 84 mm. e Ø 52 mm.).

Ogni strumento è dotato di una filettatura e di una contro ghiera che ne facilita l'installazione. Sul retro delle casse degli strumenti sono simboleggiate le connessioni per una facile installazione.

Il corpo è realizzato in Abs e la ghiera in acciaio inox verniciata epossidicamente.

GAUGE by TREM Instruments and sensors for navigation

Gauge by TREM is a wide range of high precision instruments to track navigation providing exceptional quality, bear from the synergy and an high collaboration between TR.EM, with a high knowledge in the Marine field and an established manufacturing company of instruments since a long time in the Automotive field.

Design - Product Line - Easy to install - Quality Packaging

All scales and amperage requested today are available for collection in the same standard dimension normally available (diam. 84mm and 52mm)

Each instrument is featuring a thread and a locknut that make easy his installment. On the back of the tool chests are symbolized the connections for an easy installment.

The body is made in Abs and the stainless steel focus ring is epoxy coated.



| | |
|---------------|--------------------------------|
| Ø | 52 |
| IP STANDARD | COMPLETE IP65 |
| GHIERA - RING | INOX VERNICIATO - S.S. PAINTED |
| VOLTS | 12V. |
| BOX | STAMPATA - PRINTED |

GAUGE LINE



| | |
|---------------|--------------------------------|
| Ø | 85-52 |
| IP STANDARD | FRONT IP67 - INNER IP65 |
| GHIERA - RING | INOX VERNICIATO - S.S. PAINTED |
| VOLTS | 12V. |
| BOX | STAMPATA - PRINTED |



| | |
|---------------|--------------------|
| Ø | 84-52 |
| IP STANDARD | COMPLETE IP67 |
| GHIERA - RING | AISI 316 |
| VOLTS | 12/24V. |
| BOX | STAMPATA - PRINTED |



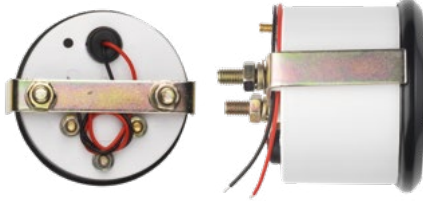

Caratteristiche tecniche

- Strumentazione IP 65
- Carcassa in tecnopolimero
- Lunetta frontale in acciaio inox verniciato
- Retroilluminazione quadrante
- Alimentazione 12V.



Technical Features

- IP 65
- Body made in technopolymer
- Frontal ring in painted stainless steel
- Backlight
- Function 12V.



CUTOUT Ø 52

Indicatore di livello carburante Fuel level gauge electrical

Impedenza 240-33 Ohms. 12V. 240-33 Ohms. 12V.

| Articolo - Item | €/pc. | Ø esterno outer mm. | Colore Colour | Ghiera Ring | kg. |
|-----------------|-------|---------------------|----------------|--------------|-------|
| L 32 80 756 | | 57 | ■ Nero-Black | ■ Nero-Black | 0,130 |
| L 32 74 756 | | 57 | □ Bianco-White | ■ Nero-Black | 0,130 |



SUGGESTED ITEM



Art. L3280040 (pag. 286)



CUTOUT Ø 52

Indicatore di livello acqua-carburante

Impedenza 10-180 Ohms. 12V.

Water-Fuel level gauge electrical

10-180 Ohms. 12V.

| Articolo - Item | €/pc. | Ø esterno outer mm. | Colore Colour | Ghiera Ring | kg. |
|-----------------|-------|---------------------|----------------|--------------|-------|
| L 32 80 766 | | 57 | ■ Nero-Black | ■ Nero-Black | 0,130 |
| L 32 74 766 | | 57 | □ Bianco-White | ■ Nero-Black | 0,130 |



SUGGESTED ITEM



Art. L3238180 (pag. 286)



CUTOUT Ø 52

Indicatore temperatura olio con sensore

50-150 gradi. DC 12V.

Oil temperature gauge electrical with sensor

50-150 degrees. DC 12V.

| Articolo - Item | €/pc. | Ø esterno outer mm. | Colore Colour | Ghiera Ring | kg. |
|-----------------|-------|---------------------|----------------|--------------|-------|
| L 32 80 733 | | 57 | ■ Nero-Black | ■ Nero-Black | 0,130 |
| L 32 74 733 | | 57 | □ Bianco-White | ■ Nero-Black | 0,130 |



COMPLETE WITH



SENSORE-SENSOR



CUTOUT Ø 52

Indicatore di temperatura fuoribordo

20-100 OHMS. Funzionamento 12V.

Outboard Temperature

20-100 OHMS. 12V.

| Articolo - Item | €/pc. | Ø esterno outer mm. | Colore Colour | Ghiera Ring | kg. |
|-----------------|-------|---------------------|----------------|--------------|-------|
| L 32 80 736 | | 57 | ■ Nero-Black | ■ Nero-Black | 0,130 |
| L 32 74 736 | | 57 | □ Bianco-White | ■ Nero-Black | 0,130 |

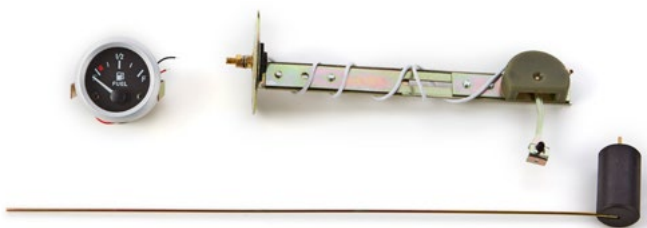

Kit indicatore di livello carburante Fuel level gauge electrical

Colore nero scritta Fuel. Completo di galleggianti.

Black colour. Fuel sign. Float included.

| Articolo - Item | €/pc. | Frequenza lavoro Working frequency Ohms | Per serbatoi For tanks |
|-----------------|-------|---|---------------------------|
| L 32 52 660 | | 240-33 | 130/660mm profondità/deep |



COMPLETE WITH



Art. L3280756 (pag. 276)

Art. L3280040 (pag. 286)

Indicatore temperatura acqua con sensore

Water temperature gauge electrical with sensor

40-120 gradi. DC 12V.

40-120 degrees. DC 12V.

| Articolo - Item | €/pc. | Ø esterno outer mm. | Colore Colour | Ghiera Ring | kg. |
|-----------------|-------|---------------------|----------------|--------------|-------|
| L 32 80 720 | | 57 | ■ Nero-Black | ■ Nero-Black | 0,130 |
| L 32 74 720 | | 57 | □ Bianco-White | ■ Nero-Black | 0,130 |



COMPLETE WITH



SENSORE-SENSOR



CUTOUT Ø 52



Indicatore di pressione olio

Oil pressure flow meter

Scala graduata da 0 a 10 Bar, 12V.
Completo di sensore pressione.

Graduated scale 0 - 10 Bar.
12V. With pressure sensor.

| Articolo - Item | €/pc. | Ø esterno outer mm. | Colore Colour | Ghiera Ring | kg. |
|-----------------|-------|---------------------|----------------|--------------|-------|
| L 32 80 734 | | 57 | ■ Nero-Black | ■ Nero-Black | 0,130 |
| L 32 74 734 | | 57 | □ Bianco-White | ■ Nero-Black | 0,130 |



COMPLETE WITH



Art. L3200534
(pag. 277)



CUTOUT Ø 52



Amperometro

Ammeter electrical

60-60A. DC 12V.

60-60A. DC 12V.

| Articolo - Item | €/pc. | Ø esterno outer mm. | Colore Colour | Ghiera Ring | kg. |
|-----------------|-------|---------------------|----------------|--------------|-------|
| L 32 80 760 | | 57 | ■ Nero-Black | ■ Nero-Black | 0,130 |
| L 32 74 760 | | 57 | □ Bianco-White | ■ Nero-Black | 0,130 |



CUTOUT Ø 52



Voltmetro

Volt gauge electrical

8-16V. DC 12V.

8-16V. DC 12V.

| Articolo - Item | €/pc. | Ø esterno outer mm. | Colore Colour | Ghiera Ring | kg. |
|-----------------|-------|---------------------|----------------|--------------|-------|
| L 32 80 718 | | 57 | ■ Nero-Black | ■ Nero-Black | 0,130 |
| L 32 74 718 | | 57 | □ Bianco-White | ■ Nero-Black | 0,130 |



CUTOUT Ø 52



ACCESSORI PER STRUMENTI DI LIVELLO | ACCESSORIES FOR ENGINE INSTRUMENTS

Sonda di «Pitot» con tubo

«Pitot» sensor with pipe

Tubo-Pipe mm.

| Articolo - Item | €/pc. | Ø est.-outer | Ø int.-inner | mt. |
|-----------------|-------|--------------|--------------|-----|
| L 32 80 000 | | 5 | 3,5 | 6,2 |



Sensore temperatura olio/acqua

Oil/water temperature sensor

| Articolo - Item | €/pc. | kg. |
|-----------------|-------|-------|
| L 32 00 533 | | 0,040 |



Sensore pressione olio

Oil pressure flow sensor

| Articolo - Item | €/pc. | kg. |
|-----------------|-------|-------|
| L 32 00 534 | | 0,150 |





Caratteristiche tecniche

- Strumentazione frontale IP67, cassa IP 65
- Carcassa in tecnopolimero
- Lunetta frontale in acciaio inox verniciato
- Retroilluminazione quadrante
- Alimentazione 12V.

Technical Features

- IP 67 frontal instruments, IP65 gauge case
- Body made in technopolymer
- Frontal ring in painted stainless steel
- Backlight
- Function 12V.

**GAUGE
LINE**



CUTOUT Ø 84

Contagiri

Scala graduata 0-6000 Rpm 12V.

Tachometer

Graduated scale 0-6000 Rpm 12V.

| Articolo - Item | €/pc. | Ø esterno outer mm. | Ø incasso cutout Ø mm. | Colore Colour | kg. |
|-----------------|-------|---------------------|------------------------|----------------|-------|
| L 32 80 600 | | 95 | 84 | ■ Nero-Black | 0,130 |
| L 32 74 600 | | 95 | 84 | □ Bianco-White | 0,130 |



CUTOUT Ø 84

Contagiri diesel

Scala graduata 0-4000 Rpm 12V.

Tachometer diesel

Graduated scale 0-4000 Rpm 12V.

| Articolo - Item | €/pc. | Ø esterno outer mm. | Ø incasso cutout Ø mm. | Colore Colour | kg. |
|-----------------|-------|---------------------|------------------------|----------------|-------|
| L 32 80 601 | | 95 | 84 | ■ Nero-Black | 0,130 |
| L 32 74 601 | | 95 | 84 | □ Bianco-White | 0,130 |



CUTOUT Ø 84

Contagiri

Scala graduata 0-7000 Rpm 12V.

Tachometer

Graduated scale 0-7000 Rpm 12V.

| Articolo - Item | €/pc. | Ø esterno outer mm. | Ø incasso cutout Ø mm. | Colore Colour | kg. |
|-----------------|-------|---------------------|------------------------|----------------|-------|
| L 32 80 700 | | 95 | 84 | ■ Nero-Black | 0,130 |
| L 32 74 700 | | 95 | 84 | □ Bianco-White | 0,130 |



CUTOUT Ø 84

Speedometro

Scala graduata 10-55 Mph e da 0-48 nodi. Indica sia le miglia che i nodi. 12V.

Speedometer

Graduated scale 10-55 Mph 0-48 knots. Speed information in knots and km. 12V.

| Articolo - Item | €/pc. | Ø esterno outer mm. | Ø incasso cutout Ø mm. | Colore Colour | kg. |
|-----------------|-------|---------------------|------------------------|----------------|-------|
| L 32 80 055 | | 95 | 84 | ■ Nero-Black | 0,130 |
| L 32 74 055 | | 95 | 84 | □ Bianco-White | 0,130 |



SUGGESTED ITEM

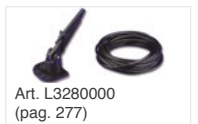

CUTOUT Ø 84

Contanodi

Scala graduata 0-50 km/h. Funzionamento 12V.

Knotmeter

Graduated scale 0-50 km/h. 12V.

| Articolo - Item | €/pc. | Ø esterno outer mm. | Ø incasso cutout Ø mm. | Colore Colour | kg. |
|-----------------|-------|---------------------|------------------------|----------------|-------|
| L 32 80 001 | | 95 | 84 | ■ Nero-Black | 0,130 |
| L 32 74 001 | | 95 | 84 | □ Bianco-White | 0,130 |



SUGGESTED ITEM



Indicatore carburante 240-33 Ohms nuovo sistema di montaggio a vite

Fuel flow meter 240-33 Ohms new screw-mounting system

Impedenza 240 - 33 Ohms, 12V.

Impedance 240 - 33 Ohms, 12V.

| Articolo - Item | €/pc. | Ø esterno outer mm. | Colore Colour | Ghiera Ring | kg. |
|-----------------|-------|---------------------|----------------|----------------|-------|
| L 32 80 656 | | 57 | ■ Nero-Black | ■ Nero-Black | 0,130 |
| L 32 74 656 | | 57 | □ Bianco-White | □ Bianco-White | 0,130 |
| L 32 32 656 | | 57 | ■ Nero-Black | ■ Aisi 316 | 0,130 |



SUGGESTED ITEM



CUTOUT Ø 52

Indicatore acqua e carburante 10-180 Ohms nuovo sistema di montaggio a vite

Fuel & water flow meter 10-180 Ohms new screw-mounting system

Impedenza 10 - 180 Ohms, 12V.

Impedance 10 - 180 Ohms, 12V.

| Articolo - Item | €/pc. | Ø esterno outer mm. | Colore Colour | Ghiera Ring | kg. |
|-----------------|-------|---------------------|----------------|----------------|-------|
| L 32 80 520 | | 57 | ■ Nero-Black | ■ Nero-Black | 0,130 |
| L 32 74 520 | | 57 | □ Bianco-White | □ Bianco-White | 0,130 |
| L 32 32 520 | | 57 | ■ Nero-Black | ■ Aisi 316 | 0,130 |



SUGGESTED ITEM



CUTOUT Ø 52

Voltmetro

Voltmeter

Scala graduata da 8 a 18V.

Graduated scale 8-18V.

| Articolo - Item | €/pc. | Ø esterno outer mm. | Colore Colour | kg. |
|-----------------|-------|---------------------|----------------|-------|
| L 32 80 018 | | 57 | ■ Nero-Black | 0,130 |
| L 32 74 018 | | 57 | □ Bianco-White | 0,130 |



CUTOUT Ø 52

Amperometro

Ammeter

Funzionamento a 12V.

Power 12V.

| Articolo - Item | €/pc. | Ø esterno outer mm. | Colore Colour | kg. |
|-----------------|-------|---------------------|----------------|-------|
| L 32 80 532 | | 57 | ■ Nero-Black | 0,130 |
| L 32 74 532 | | 57 | □ Bianco-White | 0,130 |



CUTOUT Ø 52

Contaore

Hour meter

Funzionamento a 12V.

Power 12V.

| Articolo - Item | €/pc. | Ø esterno outer mm. | Colore Colour | kg. |
|-----------------|-------|---------------------|----------------|-------|
| L 32 80 530 | | 57 | ■ Nero-Black | 0,130 |
| L 32 74 530 | | 57 | □ Bianco-White | 0,130 |



CUTOUT Ø 52



CUTOUT Ø 52



Indicatore di temperatura fuoribordo

Outboard Temperature

20-100 OHMS. Funzionamento 12V.

20-100 OHMS. 12V.

| Articolo - Item | €/pc. | Ø esterno outer mm. | Ø incasso cutout Ø mm. | Colore Colour | kg. |
|-----------------|-------|---------------------|------------------------|----------------|-------|
| L 32 80 535 | | 57 | 52 | ■ Nero-Black | 0,130 |
| L 32 74 535 | | 57 | 52 | □ Bianco-White | 0,130 |



SUGGESTED ITEM



Art. L3200533 (pag. 277)



CUTOUT Ø 52



Indicatore di temperatura acqua

Water temperature flow meter

Scala graduata da 40°C a 120°C. Funzionamento 12V. Completo di sensore.

Graduated scale 40°C - 120°C. 12V. Supplied with sensor.

| Articolo - Item | €/pc. | Ø esterno outer mm. | Ø incasso cutout Ø mm. | Colore Colour | kg. |
|-----------------|-------|---------------------|------------------------|----------------|-------|
| L 32 27 120 | | 57 | 52 | ■ Nero-Black | 0,130 |
| L 32 74 120 | | 57 | 52 | □ Bianco-White | 0,130 |



SUGGESTED ITEM



Art. L3200533 (pag. 277)



CUTOUT Ø 52



Indicatore di temperatura olio

Oil temperature flow meter

Scala graduata da 50°C a 150°C. Funzionamento 12V. Completo di sensore olio.

Graduated scale 50°C - 150°C. 12V. With oil sensor.

| Articolo - Item | €/pc. | Ø esterno outer mm. | Ø incasso cutout Ø mm. | Colore Colour | kg. |
|-----------------|-------|---------------------|------------------------|----------------|-------|
| L 32 80 533 | | 57 | 52 | ■ Nero-Black | 0,130 |
| L 32 74 533 | | 57 | 52 | □ Bianco-White | 0,130 |



SUGGESTED ITEM



Art. L3200533 (pag. 277)



CUTOUT Ø 52



Indicatore di pressione olio

Oil pressure flow meter

Scala graduata da 0 a 10 Bar, 12V. Completo di sensore pressione.

Graduated scale 0 - 10 Bar. 12V. With pressure sensor.

| Articolo - Item | €/pc. | Ø esterno outer mm. | Ø incasso cutout Ø mm. | Colore Colour | kg. |
|-----------------|-------|---------------------|------------------------|----------------|-------|
| L 32 80 534 | | 57 | 52 | ■ Nero-Black | 0,130 |
| L 32 74 534 | | 57 | 52 | □ Bianco-White | 0,130 |



TRIM 12V.

TRIM 12V.

| Articolo - Item | €/pc. | Adatto per motori For engines | Ohm | Ø esterno outer Ø mm. | Ø incasso cutout Ø mm. | Colore Colour | kg. |
|-----------------|-------|-------------------------------|------|-----------------------|------------------------|------------------|-------|
| L 32 80 521 | | Evinrude - Johnson | 5-90 | 57 | 52 | ■ Nero - Black | 0,130 |
| L 32 74 521 | | Evinrude - Johnson | 5-90 | 57 | 52 | □ Bianco - White | 0,130 |
| L 32 80 522 | | Mercury - OMC | 5-90 | 57 | 52 | ■ Nero - Black | 0,130 |
| L 32 74 522 | | Mercury - OMC | 5-90 | 57 | 52 | □ Bianco - White | 0,130 |
| L 32 80 523 | | Yamaha | 5-90 | 57 | 52 | ■ Nero - Black | 0,130 |
| L 32 74 523 | | Yamaha | 5-90 | 57 | 52 | □ Bianco - White | 0,130 |





Caratteristiche tecniche

- Strumentazione stagna IP67
- Lente trasparente anti-fog bombata
- Carcassa in tecnopolimero
- Lunetta frontale in acciaio inox Aisi 316 diamantata lucida
- Retroilluminazione quadrante
- Connessione posteriore precalibrata con spina a baionetta
- Alimentazione 12/24V.

Technical Features

- IP 67
- Anti-fog curved lens
- Body made in technopolymer
- Frontal ring in polished diamond Aisi 316 stainless steel
- Backlight
- Rear connection prewired
- Function 12V./24V.



Indicatore livello carburante

| Articolo - Item | Articolo - Item | Segnale | ↑ mm. | Volts | kg. |
|-----------------|-----------------|------------|-------------------|-------|-------|
| Nero-Black | Bianco-White | Signal | | | |
| L 32 80 033 | L 32 74 033 | 240-330hms | ext.59-int.52-H45 | 12/24 | 0,150 |
| L 32 80 180 | L 32 74 180 | 10-180hms | ext.59-int.52-H45 | 12/24 | 0,150 |

Fuel flow meter

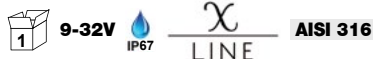

SUGGESTED ITEM

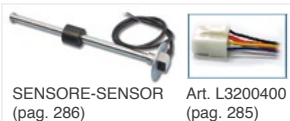

CUTOUT Ø 52

Indicatore livello acqua

| Articolo - Item | Articolo - Item | Segnale | ↑ mm. | Volts | kg. |
|-----------------|-----------------|------------|-------------------|-------|-------|
| Nero-Black | Bianco-White | Signal | | | |
| L 32 80 059 | L 32 74 059 | 240-330hms | ext.59-int.52-H45 | 12/24 | 0,150 |

Water flow meter



SUGGESTED ITEM



CUTOUT Ø 52

Indicatore temperatura acqua

| Articolo - Item | Articolo - Item | Scala | ↑ mm. | Volts | kg. |
|-----------------|-----------------|----------|-------------------|-------|-------|
| Nero-Black | Bianco-White | Scale | | | |
| L 32 80 052 | L 32 74 052 | 40-120°C | ext.59-int.52-H45 | 12/24 | 0,150 |

Water temperature indicator

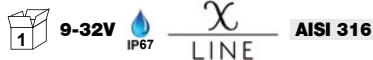

SUGGESTED ITEM



CUTOUT Ø 52

Indicatore temperatura olio

| Articolo - Item | Articolo - Item | Scala | ↑ mm. | Volts | kg. |
|-----------------|-----------------|----------|-------------------|-------|-------|
| Nero-Black | Bianco-White | Scale | | | |
| L 32 80 035 | L 32 74 035 | 50-150°C | ext.59-int.52-H45 | 12/24 | 0,150 |

Oil temperature indicator



SUGGESTED ITEM



CUTOUT Ø 52

INDICATORI E SENSORI DI LIVELLO | ENGINE INSTRUMENTS



CUTOUT Ø 52

Voltmetro

| Articolo - Item | €/pc. | Articolo - Item | €/pc. |
|-----------------|-------|-----------------|-------|
| L 32 80 020 | | L 32 74 020 | |
| L 32 80 032 | | L 32 74 032 | |

Voltmeter

| Scala | mm. | Volts | kg. |
|--------|-------------------|-------|-------|
| 8/16V | ext.59-int.52-H45 | 12 | 0,150 |
| 18/32V | ext.59-int.52-H45 | 24 | 0,150 |



9-32V IP67



AISI 316

SUGGESTED ITEM



Art. L3200400 (pag. 285)

Speedometro (a pressione acqua)

| Articolo - Item | €/pc. | Articolo - Item | €/pc. |
|-----------------|-------|-----------------|-------|
| L 32 80 155 | | L 32 74 155 | |

Speedometer (by water pressure)

| Scala | mm. | Volts | kg. |
|----------|-------------------|-------|-------|
| 0-55 MPH | ext.96-int.85-H55 | 12/24 | 0,350 |



9-32V IP67



AISI 316

SUGGESTED ITEM



Art. L3280000 (pag. 277)

Art. L3200400 (pag. 285)



CUTOUT Ø 85

Speedometro GPS

| Articolo - Item | €/pc. | Articolo - Item | €/pc. |
|-----------------|-------|-----------------|-------|
| L 32 80 015 | | L 32 74 015 | |
| L 32 80 030 | | L 32 74 030 | |
| L 32 80 060 | | L 32 74 060 | |

GPS Speedometer

| Display Range | mm. | Volts | kg. |
|-----------------|-------------------|-------|-------|
| 0-15 Nodi-Knots | ext.96-int.85-H55 | 12 | 0,350 |
| 0-30 Nodi-Knots | ext.96-int.85-H55 | 12 | 0,350 |
| 0-60 Nodi-Knots | ext.96-int.85-H55 | 12 | 0,350 |



9-32V IP67



AISI 316

SUGGESTED ITEM



Art. L3280000 (pag. 277)

Art. L3200400 (pag. 285)



CUTOUT Ø 85

Contagiri elettronico universale con contaore

| Articolo - Item | €/pc. | Articolo - Item | €/pc. |
|-----------------|-------|-----------------|-------|
| L 32 80 401 | | L 32 74 401 | |
| L 32 80 602 | | L 32 74 602 | |

Universal tachometer with hour meter

| Scala | mm. | Volts | kg. |
|-----------|-------------------|-------|-------|
| 0-4000RPM | ext.96-int.85-H55 | 12/24 | 0,350 |
| 0-6000RPM | ext.96-int.85-H55 | 12/24 | 0,350 |



9-32V IP67



AISI 316

SUGGESTED ITEM



Art. L3200400 (pag. 285)



CUTOUT Ø 85

Indicatore pressione olio

| Articolo - Item | €/pc. | Articolo - Item | €/pc. |
|-----------------|-------|-----------------|-------|
| L 32 80 653 | | L 32 74 653 | |

Oil pressure indicator

| Scala | mm. | Volts | kg. |
|----------|-------------------|-------|-------|
| 0-10 bar | ext.59-int.52-H45 | 12/24 | 0,150 |



9-32V IP67



AISI 316

SUGGESTED ITEM



Art. L3200400 (pag. 285)



CUTOUT Ø 52

Indicatore TRIM

TRIM Indicator

| Articolo - Item | €/pc. | Articolo - Item | €/pc. | Segnale | mm. | Volts | kg. |
|-----------------|-------|-----------------|-------|---------|-------------------|-------|-------|
| Nero-Black | | Bianco-White | | Signal | ↕ | | |
| L 32 80 631 | | L 32 74 631 | | 0-190 | ext.59-int.52-H45 | 12/24 | 0,150 |



SUGGESTED ITEM



CUTOUT Ø 52

Amperometro

Amperometer

| Articolo - Item | €/pc. | Articolo - Item | €/pc. | Segnale | mm. | Volts | kg. |
|-----------------|-------|-----------------|-------|----------|-------------------|-------|-------|
| Nero-Black | | Bianco-White | | Signal | ↕ | | |
| L 32 80 633 | | L 32 74 633 | | +/- 80 A | ext.59-int.52-H45 | 12/24 | 0,150 |



SUGGESTED ITEM

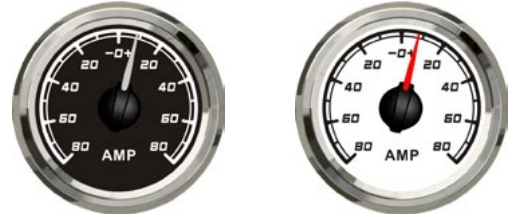

CUTOUT Ø 52

Indicatore acque nere

Waste gauge

| Articolo - Item | €/pc. | Articolo - Item | €/pc. | Segnale | mm. | Volts | kg. |
|-----------------|-------|-----------------|-------|-------------|-------------------|-------|-------|
| Nero-Black | | Bianco-White | | Signal | ↕ | | |
| L 32 80 652 | | L 32 74 652 | | 10-180 Ohms | ext.59-int.52-H45 | 12/24 | 0,150 |



SUGGESTED ITEM

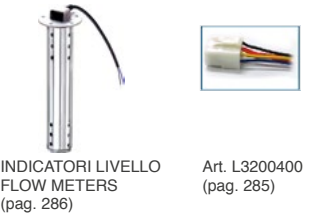

CUTOUT Ø 52

Contaore digitale

Digital hour meter

| Articolo - Item | €/pc. | Articolo - Item | €/pc. | Scala | mm. | Volts | kg. |
|-----------------|-------|-----------------|-------|----------|-------------------|-------|-------|
| Nero-Black | | Bianco-White | | Scale | ↕ | | |
| L 32 80 630 | | L 32 74 630 | | 0-99999H | ext.59-int.52-H45 | 12/24 | 0,150 |



SUGGESTED ITEM



CUTOUT Ø 52

Indicatore allarme 4 utenze

4 LED alarm gauge

| Articolo - Item | €/pc. | Articolo - Item | €/pc. | Segnale | mm. | Volts | kg. |
|-----------------|-------|-----------------|-------|---------|-------------------|-------|-------|
| Nero-Black | | Bianco-White | | Signal | ↕ | | |
| L 32 80 952 | | L 32 74 952 | | Switch | ext.59-int.52-H45 | 12/24 | 0,150 |



SUGGESTED ITEM



CUTOUT Ø 52



CUTOUT Ø 52

Voltmetro digitale

Digital voltmeter

| Articolo - Item | €/pc. | Articolo - Item | €/pc. | Scala | ↑ mm. | Volts | kg. |
|-----------------|-------|-----------------|-------|-------|-------------------|-------|-------|
| L 32 80 121 | | L 32 74 121 | | 9/32V | ext.59-int.52-H45 | 12/24 | 0,150 |



9-32V



AISI 316

SUGGESTED ITEM



Art. L3200400
(pag. 285)

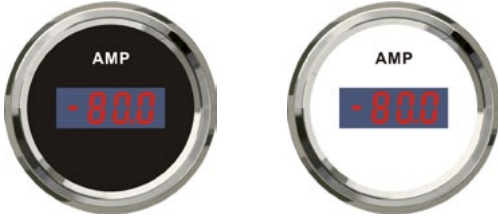

CUTOUT Ø 52

Amperometro digitale

Digital amperometer

| Articolo - Item | €/pc. | Articolo - Item | €/pc. | Scala | ↑ mm. | Volts | kg. |
|-----------------|-------|-----------------|-------|----------|-------------------|-------|-------|
| L 32 80 632 | | L 32 74 632 | | +/- 80 A | ext.59-int.52-H45 | 12/24 | 0,150 |



9-32V



AISI 316

SUGGESTED ITEM



Art. L3200400
(pag. 285)



CUTOUT Ø 52

Indicatore carburante digitale

Digital fuel level

| Articolo - Item | €/pc. | Articolo - Item | €/pc. | Segnale | Display | ↑ mm. | Volts | kg. |
|-----------------|-------|-----------------|-------|----------|---------|-------------------|-------|-------|
| L 32 80 190 | | L 32 74 190 | | 0-190 Ω | 0-100% | ext.59-int.52-H45 | 12/24 | 0,150 |
| L 32 80 240 | | L 32 74 240 | | 240-33 Ω | 0-100% | ext.59-int.52-H45 | 12/24 | 0,150 |



9-32V



AISI 316

SUGGESTED ITEM



Art. L3200400
(pag. 285)



CUTOUT Ø 52

Indicatore pressione olio digitale

Digital oil pressure

| Articolo - Item | €/pc. | Articolo - Item | €/pc. | Segnale | Display | ↑ mm. | Volts | kg. |
|-----------------|-------|-----------------|-------|----------|----------|-------------------|-------|-------|
| L 32 80 184 | | L 32 74 184 | | 10-184 Ω | 0-5 Bar | ext.59-int.52-H45 | 12/24 | 0,150 |
| L 32 80 185 | | L 32 74 185 | | 10-184 Ω | 0-10 Bar | ext.59-int.52-H45 | 12/24 | 0,150 |



9-32V



AISI 316

SUGGESTED ITEM



Art. L3200400
(pag. 285)



CUTOUT Ø 52

Indicatore temperatura acqua digitale

Digital water temperature

| Articolo - Item | €/pc. | Colore | Segnale | Display | ↑ mm. | Volts | kg. |
|-----------------|-------|----------------|---------------|----------|-------------------|-------|-------|
| L 32 25 120 | | ■ Nero-Black | Matched w/KUS | 25-120°C | ext.59-int.52-H45 | 12/24 | 0,150 |
| L 32 00 120 | | □ Bianco-White | temp. sensor | 25-120°C | ext.59-int.52-H45 | 12/24 | 0,150 |



9-32V



AISI 316

SUGGESTED ITEM



Art. L3200400
(pag. 285)

Indicatore angolo di barra

Rudder angle indicator

| Articolo - Item | €/pc. | Articolo - Item | €/pc. | Segnale Signal | Display range | ↕ mm. | Volts | kg. |
|-----------------|-------|-----------------|-------|-------------------|------------------|-------------------|-------|-------|
| L 32 80 085 | | L 32 74 085 | | 0-190 Ω | R/L | ext.96-int.85-H55 | 12/24 | 0,350 |



SUGGESTED ITEM

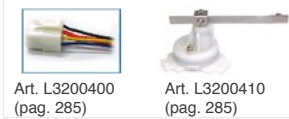

CUTOUT Ø 85

Sensore angolo di barra

Rudder angle sensor

| Articolo - Item | €/pc. | Segnale Signal | Cavi collegati Connecting wires | Strumenti collegati Connecting gauges | kg. |
|-----------------|-------|--------------------------|------------------------------------|--|-----|
| L 32 00 410 | | Single output 0-190 Ω | 2 | 1 | |



Connettore cablato per strumenti X-Line

Wired connector for X-Line instruments

| Articolo - Item | €/pc. | Cablaggio-Wiring Lunghezza-Length mm. | kg. |
|-----------------|-------|--|-------|
| L 32 00 400 | | 400 | 0,030 |

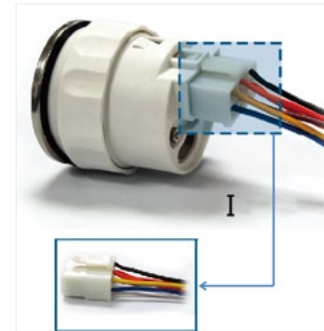

CONNETTORI NMEA 2000 | CONNECTORS NMEA 2000

Connettori NMEA 2000

Connectors NMEA 2000

| Articolo - Item | €/pc. | Description |
|-----------------|-------|---|
| L 32 11 051 | | Cavo maschio/femmina-Male/female cable 1 mt. |
| L 32 11 055 | | Cavo maschio/femmina-Male/female cable 5 mt. |
| L 32 11 057 | | Cavo maschio/femmina-Male/female cable 10 mt. |
| L 32 11 043 | | Cavo di alimentazione con terminale a TEE-Power cable TEE 2 mt. |
| L 32 11 031 | | TEE 2 femmine/1 maschio-TEE 2 females/1 male |
| L 32 11 013 | | Connettore femmina-Female connector |
| L 32 11 011 | | Connettore maschio-Male connector |
| L 32 11 017 | | Terminale femmina-Female terminal |
| L 32 11 015 | | Terminale maschio-Male terminal |
| L 32 11 033 | | Adattatore a TEE 2 vie-TEE Adapter 2 ways |
| L 32 11 035 | | Adattatore a TEE 4 vie-TEE Adapter 4 ways |



Galleggiante per strumenti di livello carburante

12V. Universale, adattabile a tutti gli strumenti in commercio.
Regolabile per serbatoi da 13 cm. a 68 cm.

Level sensor for fuel tanks

12V. Universal model, suitable to be used with all engine instruments on market.
For fuel tanks 13 - 68 cm.

| Articolo - Item | €/pc. | Frequenza lavoro Working frequency Ohms | Adatto per foro For hole Ø mm. | kg. |
|-----------------|-------|--|-----------------------------------|-------|
| L 32 80 040 | | 240 - 33 | 38 | 0,280 |
| L 32 38 180 | | 10 - 180 | 38 | 0,280 |

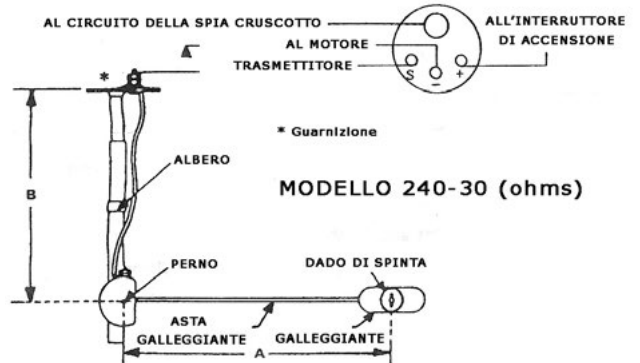

Sensore di livello «WEMA»

Funzionamento a 12V.

Flow meter «WEMA»

12V.

| 240-33 | | 10-180 | | Sonda-Sensor | kg. |
|-----------------|-------|-----------------|-------|----------------------|-------|
| Articolo - Item | €/pc. | Articolo - Item | €/pc. | Lunghezza length cm. | |
| L 32 30 120 | | L 32 80 120 | | 12 | 0,200 |
| L 32 30 150 | | L 32 80 150 | | 15 | 0,210 |
| L 32 30 170 | | L 32 80 170 | | 17 | 0,220 |
| L 32 30 200 | | L 32 80 200 | | 20 | 0,250 |
| L 32 30 220 | | - | | 22 | - |
| L 32 30 250 | | L 32 80 250 | | 25 | 0,260 |
| L 32 30 280 | | - | | 28 | - |
| L 32 30 290 | | L 32 80 300 | | 30 | 0,270 |
| L 32 30 320 | | - | | 32 | - |
| L 32 30 350 | | L 32 80 350 | | 35 | 0,300 |
| L 32 30 360 | | - | | 36 | - |
| L 32 30 380 | | L 32 80 380 | | 38 | 0,350 |
| L 32 30 400 | | L 32 80 400 | | 40 | - |
| L 32 30 450 | | L 32 80 450 | | 45 | 0,400 |
| L 32 30 470 | | - | | 47 | - |
| L 32 30 480 | | - | | 48 | - |
| L 32 30 500 | | L 32 80 500 | | 50 | 0,500 |
| L 32 30 520 | | - | | 52 | - |
| - | | L 32 80 550 | | 55 | - |
| L 32 30 580 | | - | | 58 | - |
| L 32 30 600 | | L 32 80 599 | | 60 | 0,600 |
| L 32 30 650 | | L 32 80 650 | | 65 | 0,650 |



Sensore di livello verticale per acque nere e chiare

Completamente in acciaio inox, dotato di una copertura inox che evita l'entrata dello sporco.
Flangia internazionale a 5 fori. impedenza 10-180 Ω.
Temperatura di lavoro da -40° a +85°

Vertical level sensor for black and clear waters

Manufactured in stainless steel. Equipped with a stainless steel coating avoiding dirt to enter.
5-bore international flange. 10-180 Ω frequency.
Working temperature from -40° till +85°

| Articolo - Item | €/pc. | Lunghezza-Length cm. | kg. |
|-----------------|-------|----------------------|-----|
| L 32 10 025 | | 25 | |



VOLANTI | WHEELS

Volante VR00

- Diametro: 280 mm.
 - Impugnatura: Megol effetto pelle
 - Razze: PP effetto carbonio
- Conforme alle normative:
UNI EN 28848 - UNI EN 29775 - UNI EN ISO 10592.
Mozzo con attacco universale.

Rudder wheel VR00

- Diameter: 280 mm.
 - Impugnatura: Megol leather effect
 - Razze: PP carbon effect
- In conformity with:
UNI EN 28848 - UNI EN 29775 - UNI EN ISO 10592.
Standard hub.

| Articolo - Item | €/pc. | Colore Colour | kg. |
|-----------------|-------|------------------|-----|
| L 51 28 080 | | ■ Nero-Black | |
| L 51 28 074 | | ■ Bianco-White | |
| L 51 28 079 | | ■ Grigio-Grey | |



Volante VR01

- Diametro: 325 mm.
 - Impugnatura: Megol
 - Razze: Acciaio inox
- Cert. di esame CE in accordo con le direttive 2013/53/EU.

Rudder wheel VR01

- Diameter: 325 mm.
 - Impugnatura: Megol
 - Razze: Stainless steel
- Exam Certification CE according to the directive 2013/53/EU SAFETY STANDARDS.

| Articolo - Item | €/pc. | Colore Colour | kg. |
|-----------------|-------|------------------|-----|
| L 51 32 080 | | ■ Nero-Black | |
| L 51 32 079 | | ■ Grigio-Grey | |



Volante VR03

- Diametro: 400 mm.
 - Impugnatura: Megol
 - Razze: Acciaio inox
- Cert. di esame CE in accordo con le direttive 2013/53/EU.

Rudder wheel VR03

- Diameter: 400 mm.
 - Impugnatura: Megol
 - Razze: Stainless steel
- Exam Certification CE according to the directive 2013/53/EU SAFETY STANDARDS.

| Articolo - Item | €/pc. | Colore Colour | kg. |
|-----------------|-------|------------------|-----|
| L 51 39 080 | | ■ Nero-Black | |
| L 51 39 074 | | ■ Bianco-White | |



Volante VR02

- Diametro: 350 mm.
 - Impugnatura: Megol
 - Razze: Acciaio inox
- Cert. di esame CE in accordo con le direttive 2013/53/EU.

Rudder wheel VR02

- Diameter: 350 mm.
 - Impugnatura: Megol
 - Razze: Stainless steel
- Exam Certification CE according to the directive 2013/53/EU SAFETY STANDARDS.

| Articolo - Item | €/pc. | Colore Colour | kg. |
|-----------------|-------|------------------|-----|
| L 51 35 080 | | ■ Nero-Black | |
| L 51 35 074 | | ■ Bianco-White | |
| L 51 35 079 | | ■ Grigio-Grey | |



VOLANTI | WHEELS

Ruota timone a cinque razze in acciaio inox mod. «Race»

Certificato CE secondo la norma EN 28848. Corona e razze in acciaio inox lucidato. Provvista di mozzo centrale in acciaio inox, copri mozzo in Teak verniciato.

| Articolo - Item | €/pc. | Razze Spokes | Ø mm. | kg. |
|-----------------|-------|--------------|-------|-----|
| L 51 32 004 | | 5 | 320 | |

**Rudder wheel in tainless steel mod. «Race» 5 spokes**

Round tube and spokes in stainless steel. Central hub in stainless steel.

Volanti in acciaio inox Aisi 316 Rudder wheels Aisi 316 S.S.

| Articolo - Item | €/pc. | Razze Spokes | Ø mm. | Tube-Tube Ø mm. | kg. |
|-----------------|-------|--------------|-------|-----------------|-------|
| L 51 32 403 | | 5 | 457 | 22 | 1,390 |
| L 51 32 404 | | 5 | 510 | 22 | 1,060 |

**Volanti in acciaio inox con guaina in polipropilene**

| Articolo - Item | €/pc. | Colore Colour | Razze Spokes | Ø mm. | Tube-Tube Ø mm. | kg. |
|-----------------|-------|---------------|--------------|-------|-----------------|-------|
| L 51 73 060 | | Black | 5 | 340 | 22 | 1,420 |
| L 51 74 061 | | White | 5 | 400 | 22 | 1,520 |
| L 51 73 061 | | Black | 5 | 400 | 22 | 1,520 |

**Rudder wheels in stainless steel with Polyurethane covering****Volante mod. «Racing» a tre razze**

Certificato CE secondo la norma EN 28848. Volante di tipo sportivo. Attacco universale. Colore nero.

Rudder wheel mod. «Racing»

CE according to EN 28848 Rule. Sports-style control wheel. Universal connector. Black colour.

| Articolo - Item | €/pc. | Razze Spokes | Ø mm. | kg. |
|-----------------|-------|--------------|-------|-----|
| L 51 52 000 | | 3 | 350 | |

**Pomolo girevole per volanti fabbricato in acciaio inox**

Per tubo 20 - 25 mm.

Steering wheel turning knob in stainless steel

For pipe 20 - 25 mm.

| Articolo - Item | €/pc. | H mm. | Pomolo Ø mm. | kg. |
|-----------------|-------|-------|--------------|-------|
| L 51 25 038 | | 52 | 40 | 0,220 |



COME INDIVIDUARE TIMONERIE E TELECOMANDI HOW TO FIND STEERING SYSTEMS & CONTROL CABLES

TABELLA CONVERSIONE PIEDI-METRI
CONVERSION TABLE FEET-METERS

| PIEDI-Feet | METRI-Meters | PIEDI-Feet | METRI-Meters |
|------------|--------------|------------|--------------|
| 5' | 1,53 | 23' | 7,03 |
| 6' | 1,83 | 24' | 7,33 |
| 7' | 2,14 | 25' | 7,62 |
| 8' | 2,44 | 26' | 7,93 |
| 9' | 2,75 | 27' | 8,23 |
| 10' | 3,05 | 28' | 8,54 |
| 11' | 3,36 | 29' | 8,84 |
| 12' | 3,66 | 30' | 9,15 |
| 13' | 3,97 | 31' | 9,45 |
| 14' | 4,27 | 32' | 9,76 |
| 15' | 4,59 | 33' | 10,06 |
| 16' | 4,88 | 34' | 10,37 |
| 17' | 5,19 | 35' | 10,67 |
| 18' | 5,49 | 36' | 10,98 |
| 19' | 5,80 | 37' | 11,28 |
| 20' | 6,10 | 38' | 11,58 |
| 21' | 6,41 | 39' | 11,89 |
| 22' | 6,72 | 40' | 12,20 |

COME RILEVARE LA LUNGHEZZA DEL TELECOMANDO
HOW TO MEASURE THE LENGTH OF CONTROL CABLE

FUORIBORDO / OUTBOARD
 $A + B + 3' (90\text{cm}) = L$

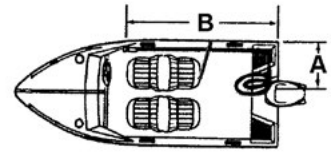

ENTROBORDO / INBOARD
ENTROFUORIBORDO / STERNDRIVE
 $A + B = L$

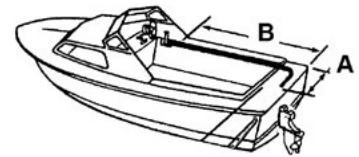

COME INDIVIDUARE LA LUNGHEZZA DEL MONOCAVO HOW TO MEASURE THE LENGTH OF STEERING CABLE

LUNGHEZZA DA ORDINARE-LENGTH TO BE ORDERED

Indicare la misura "X" ed aggiungere 46 cm.
Esempio: "X"+46=Lunghezza monocavo in cm.

Take "X" size and add 46 cm.
Example: "X"+46=steering cable length in cm.

Per ottenere la lunghezza in piedi, dividere il risultato per 30,5 e arrotondare al valore superiore.
Esempio: $X=305\text{ cm} + 46\text{ cm} = 351/30,5=11,51$. Arrotondare a 12ft.

To get the length in feet, divide by 30,5 and round to the upper value.
Example: $X=305\text{ cm} + 46\text{ cm} = 351/30,5+11,51$. Round to 12ft.



TABELLA COMPARATIVA-TABLE OF COMPARISON

| MOTORI-ENGINES | | CAVI TELECOMANDO-CONTROL CABLES | | |
|-------------------------------|---|---------------------------------|--------------------|--|
| | | UFLEX | SEASTAR | MAVIMARE |
| FUORIBORDO OUTBOARD | Mercury Scatole GEN II | C36 - MACH36 | - | C-036-C-MACH36 |
| | Mercury Mariner > 50HP | C5-MACH5 | CC179-CCX179 | C-045 (pag. 291) C-MACH45 (pag. 291) |
| | Force Selva Yamaha Suzuki Tohatsu Honda Nissan | C2-C8-MACH0 | CC230-CC330-CCX633 | C-042 (pag. 291) C-048 (pag. 291) C-MACH0 (pag. 291) |
| | Johnson-Evinrude-BRP | Dopo il-After 1979 C14-MACH14 | CC205 | C-414 (pag. 291) C-MACH14 |
| ENTROFUORIBORDO STERNDRIVE | Mercuriser Scatole GEN II | C36-MACH36 | - | C-036-C-MACH14 |
| | OMC-BRP | Dopo il-After 1979 C14-MACH14 | CC205 | C-414 (pag. 291) C-MACH14 |
| | Volvo-Penta Yanmar Vollswagen | C2-C8-MACH0 | CC230-CC330-CCX633 | C-042 (pag. 291) C-048 (pag. 291) C-MACH0 (pag. 291) |
| ENTROBORDO / INBOARD | | C2-C8-MACH0-C22 | CC230-CC330-CCX633 | C-042 (pag. 291) C-048 (pag. 291) C-MACH0 (pag. 291) |

TABELLA COMPARATIVA CODICI SCATOLE TIMONERIE MECCANICHE E MONOCAVI
COMPARISON TABLE OF MECHANICAL STEERING SYSTEMS AND STEERING CABLES

| SEASTAR | ULTRAFLEX | MANCINI | CARATTERISTICHE-SPECIFICATIONS |
|------------|-----------|----------|--|
| SH-8050-1P | T67 | G.10 | Timoneria meccanica fuoribordo max 50HP, NO no-feedback Steering system for outboard engine max 50HP, NO no-feedback |
| SH5180 | T71FC | G.12 | Timoneria meccanica fuoribordo, pignone centrale, NO no-feedback Steering system for outboard engine, central shaft, NO no-feedback |
| SSC131XXB | M58 | C.614.05 | Monocavo timoneria fino a 50HP Steering cable up to 50HP |
| SSC62XXB | M66 | C.17.05 | Monocavo timoneria STANDARD Steering cable STANDARD |

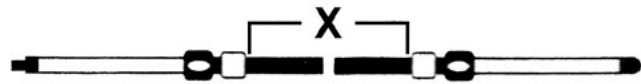
COME RILEVARE LA LUNGHEZZA DELLA TIMONERIA HOW TO MEASURE THE LENGTH OF THE STEERING CABLE

Sommare A+B+C e togliere 10 cm per ciascuna curva del cavo a 90°.
Se il motore è dotato di tubo di fissaggio del monocavo, aggiungere 30,5 cm (1ft.) alla lunghezza come sopra ottenuta. Per ottenere la lunghezza in piedi, dividere il risultato per 30,5 e arrotondare al valore superiore.

Add A+B+C and subtract 10 cm (4") for each 90° bend in the cable.
For installation through the engine tilt tube, add 30,5 cm (1ft.) to the measure calculated above.
To order in feet length, divide by 30,5 and round off to next whole foot.

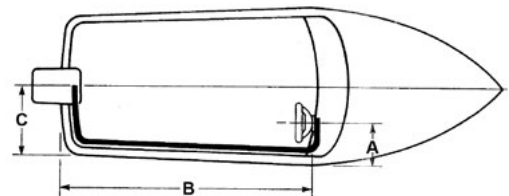



Telecomando bileva mod. «Universale» originale per applicazione laterale ambidestra

Comandi per l'applicazione a parete laterale destra o sinistra, adattabili su qualsiasi tipo di motore fuoribordo. Corpo in Hostaform e leve in anticorodal. Corredato di adattatori per cavi indicati per motore Yamaha, Suzuki, Mariner, Johnson, Evinrude, Selva. Movimento autofrizionante.

Bi-lever control system mod. «Universale» side mounting

Manufactured in Hostaform. To be mounted right or left position. Levers in light alloy aluminium. Complete with connectors for engine cable Yamaha, Suzuki, Mariner, Johnson, Evinrude, Selva.

| Articolo - Item | €/pc. | Colore Colour | mm. | kg. |
|-----------------|-------|----------------|---------|-----|
| L 53 11 228 | | ■ Nero-Black | 114x228 | |
| L 53 74 228 | | □ Bianco-White | 114x228 | |

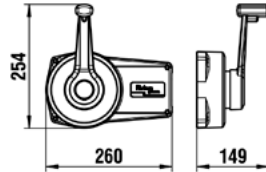

Telecomando «Riviera» CM01

- Installazione: a parete
- Sicurezza: meccanica
- Corsa accel.: 88
- Corsa invertitore: 68-76

Compatibile con cavi Riviera mod. F14/F05 e con adattatore fornito di serie, con cavi mod. F02/F08.

Control system box «Riviera» CM01

- Installation: wall mount
- Safety: mechanical
- Accelerator stroke: 88
- Inverter stroke: 68-76

For use with Riviera mod. F14/F05 cables and with Riviera F02/F08 cables. The adaptor is included.

| Articolo - Item | €/pc. | Colore Colour | kg. |
|-----------------|-------|----------------|-----|
| L 53 80 090 | | ■ Nero-Black | |
| L 53 74 090 | | □ Bianco-White | |

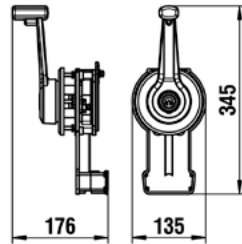

Telecomando «Riviera» CM02

- Installazione: incasso
- Sicurezza: meccanica
- Corsa accel.: 88
- Corsa invertitore: 68-76

Compatibile con cavi Riviera mod. F14/F05 e con adattatore fornito di serie, con cavi mod. F02/F08.

Control system box «Riviera» CM02

- Installation: flush mount
- Safety: mechanical
- Accelerator stroke: 88
- Inverter stroke: 68-76

For use with Riviera mod. F14/F05 cables and with Riviera F02/F08 cables. The adaptor is included.

| Articolo - Item | €/pc. | Colore Colour | kg. |
|-----------------|-------|----------------|-----|
| L 53 80 083 | | ■ Nero-Black | |
| L 53 74 083 | | □ Bianco-White | |

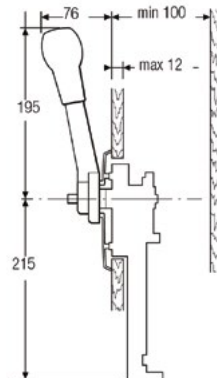

Comando monoleva «Teleflex» 700SS

Comando monoleva a doppia azione, montaggio a paratia per il controllo di gas e marce su motori entrofuoribordo. Di serie sui motori Volvo e Vetus. Utilizza cavi C2/C8/C33/MACHZero.

Control system box «Teleflex» 700SS

Dual action side mount control designed for sail boats. Suits C2/C8/C33/MACHZero type cables.

| Articolo - Item | €/pc. | Colore Colour | kg. |
|-----------------|-------|---------------|-----|
| L 53 12 215 | | ■ Nero-Black | |



Comando Top Mount Morse MT3 Top Mount Control Morse MT3

Comando a doppia azione per il controllo di gas e marce su motori entro/fuoribordo. Leva e corpo in lega inossidabile cromata, montaggio su plancia. Utilizza cavi C2/C8/C33/MACHZero.

Dual action (throttle and shift in one lever). Chrome finish. Flush mount. Suits C2/C8/C33/MACHZero type cables.

| Articolo - Item | €/pc. | Leva-Lever | kg. |
|-----------------|-------|----------------|-----|
| L 53 03 001 | | Singola-Single | |
| L 53 03 002 | | Doppia-Double | |

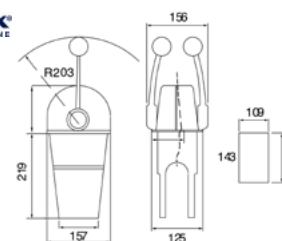

Cavi telecomando «Mavimare»

Control cables «Mavimare»

| Piedi Feet | mt. | Art. C2-C042 | €/pc. | Art. C4 | €/pc. | Art. C5-C045 | €/pc. | Art. C14-C414 | €/pc. | Art. C8-C048 | €/pc. | Art. MACH0 C-MACH0 | €/pc. | Art. MACH5 C-MACH45 | €/pc. |
|---------------|------|--------------|-------|-------------|-------|--------------|-------|---------------|-------|--------------|-------|-----------------------|-------|------------------------|-------|
| 8 | 2.44 | L 53 08 302 | - | - | - | - | - | L 53 08 314 | - | L 53 08 308 | - | L 53 08 300 | - | L 53 08 045 | - |
| 9 | 2.74 | L 53 09 302 | - | - | - | - | - | L 53 09 314 | - | L 53 09 308 | - | L 53 09 300 | - | L 53 09 045 | - |
| 10 | 3.05 | L 53 10 302 | - | - | - | - | - | L 53 10 314 | - | L 53 10 308 | - | L 53 10 300 | - | L 53 10 045 | - |
| 11 | 3.35 | L 53 11 302 | - | - | - | - | - | L 53 11 314 | - | L 53 11 308 | - | L 53 11 300 | - | L 53 11 045 | - |
| 12 | 3.66 | L 53 12 302 | - | L 53 12 304 | - | - | - | L 53 12 314 | - | L 53 12 308 | - | L 53 12 300 | - | L 53 12 045 | - |
| 13 | 3.96 | L 53 13 302 | - | L 53 13 304 | - | L 53 13 305 | - | L 53 13 314 | - | L 53 13 308 | - | L 53 13 300 | - | L 53 13 045 | - |
| 14 | 4.27 | L 53 14 302 | - | L 53 14 304 | - | L 53 14 305 | - | L 53 14 314 | - | L 53 14 308 | - | L 53 14 300 | - | L 53 14 045 | - |
| 15 | 4.57 | L 53 15 302 | - | L 53 15 304 | - | L 53 15 305 | - | L 53 15 314 | - | L 53 15 308 | - | L 53 15 300 | - | L 53 15 045 | - |
| 16 | 4.88 | - | - | L 53 16 304 | - | L 53 16 305 | - | - | - | L 53 16 308 | - | L 53 16 300 | - | L 53 16 045 | - |
| 17 | 5.18 | L 53 17 302 | - | L 53 17 304 | - | L 53 17 305 | - | - | - | L 53 17 308 | - | L 53 17 300 | - | L 53 17 045 | - |
| 18 | 5.49 | L 53 18 302 | - | L 53 18 304 | - | L 53 18 305 | - | - | - | L 53 18 308 | - | L 53 18 300 | - | L 53 18 045 | - |
| 19 | 5.80 | - | - | - | - | L 53 19 305 | - | - | - | L 53 19 308 | - | L 53 19 300 | - | L 53 19 045 | - |
| 20 | 6.10 | - | - | - | - | L 53 20 305 | - | - | - | L 53 20 308 | - | L 53 20 300 | - | L 53 20 045 | - |
| 21 | 6.41 | - | - | - | - | - | - | - | - | L 53 21 308 | - | L 53 21 300 | - | L 53 21 045 | - |
| 22 | 6.72 | - | - | - | - | - | - | - | - | L 53 22 308 | - | L 53 22 300 | - | L 53 22 045 | - |
| 23 | 7.03 | - | - | - | - | - | - | - | - | L 53 23 308 | - | L 53 23 300 | - | L 53 23 045 | - |
| 24 | 7.33 | - | - | - | - | - | - | - | - | L 53 24 308 | - | L 53 24 300 | - | L 53 24 045 | - |

| FOTO-PICTURE | Art. MAVIMARE | Art. ULTRAFLEX |
|--------------|---------------|----------------|
| | C042 | C2 |
| | - | C4 |
| | C045 | C5 |
| | C414 | C14 |
| | C048 | C8 |
| | C-MACH0 | MACH0 |
| | C-MACH45 | MACH5 |



Cavi telecomando «Sea Star»

Control cables «Sea Star»

| Piedi Feet | mt. | Art. C230 | €/pc. | Art. C332 RED | €/pc. | Art. CC179 | €/pc. | Art. CC205 | €/pc. | Art. CC330 | €/pc. | Art. CCX633 | €/pc. | Art. CCX179 | €/pc. |
|---------------|-------|-------------|-------|------------------|-------|-------------|-------|-------------|-------|-------------|-------|-------------|-------|-------------|-------|
| 8 | 2,44 | L 53 08 230 | - | L 53 08 332 | - | L 53 08 179 | - | L 53 08 205 | - | L 53 08 330 | - | L 53 08 633 | - | L 53 08 005 | - |
| 9 | 2,75 | L 53 09 230 | - | L 53 09 332 | - | L 53 09 179 | - | L 53 09 205 | - | L 53 09 330 | - | L 53 09 633 | - | L 53 09 000 | - |
| 10 | 3,05 | L 53 10 230 | - | L 53 10 332 | - | L 53 10 179 | - | L 53 10 205 | - | L 53 10 330 | - | L 53 10 633 | - | L 53 10 000 | - |
| 11 | 3,36 | L 53 11 230 | - | L 53 11 332 | - | L 53 11 179 | - | L 53 11 205 | - | L 53 11 330 | - | L 53 11 633 | - | L 53 11 000 | - |
| 12 | 3,66 | L 53 12 230 | - | L 53 12 332 | - | L 53 12 179 | - | L 53 12 205 | - | L 53 12 330 | - | L 53 12 633 | - | L 53 12 000 | - |
| 13 | 3,97 | L 53 13 230 | - | L 53 13 332 | - | L 53 13 179 | - | L 53 13 205 | - | L 53 13 330 | - | L 53 13 633 | - | L 53 13 000 | - |
| 14 | 4,27 | L 53 14 230 | - | L 53 14 332 | - | L 53 14 179 | - | L 53 14 205 | - | L 53 14 330 | - | L 53 14 633 | - | L 53 14 001 | - |
| 15 | 4,59 | L 53 15 230 | - | L 53 15 332 | - | L 53 15 179 | - | L 53 15 205 | - | L 53 15 330 | - | L 53 15 633 | - | L 53 15 000 | - |
| 16 | 4,88 | L 53 16 230 | - | L 53 16 332 | - | L 53 16 179 | - | L 53 16 205 | - | L 53 16 330 | - | L 53 16 633 | - | L 53 16 000 | - |
| 17 | 5,19 | L 53 17 230 | - | L 53 17 332 | - | L 53 17 179 | - | L 53 17 205 | - | L 53 17 330 | - | L 53 17 633 | - | L 53 17 000 | - |
| 18 | 5,49 | L 53 18 230 | - | L 53 18 332 | - | L 53 18 179 | - | L 53 18 205 | - | L 53 18 330 | - | L 53 18 633 | - | L 53 18 000 | - |
| 19 | 5,80 | L 53 19 230 | - | L 53 19 332 | - | L 53 19 179 | - | L 53 19 205 | - | L 53 19 330 | - | L 53 19 633 | - | L 53 19 000 | - |
| 20 | 6,10 | L 53 20 230 | - | L 53 20 332 | - | L 53 20 179 | - | L 53 20 205 | - | L 53 20 330 | - | L 53 20 633 | - | L 53 20 001 | - |
| 21 | 6,41 | L 53 21 230 | - | L 53 21 332 | - | L 53 21 179 | - | L 53 21 205 | - | L 53 21 330 | - | L 53 21 633 | - | L 53 21 000 | - |
| 22 | 6,72 | L 53 22 230 | - | L 53 22 332 | - | L 53 22 179 | - | L 53 22 205 | - | L 53 22 330 | - | L 53 22 633 | - | L 53 22 000 | - |
| 23 | 7,03 | L 53 23 230 | - | L 53 23 332 | - | L 53 23 179 | - | L 53 23 205 | - | L 53 23 330 | - | L 53 23 633 | - | L 53 23 000 | - |
| 24 | 7,33 | L 53 24 230 | - | L 53 24 332 | - | L 53 24 179 | - | L 53 24 205 | - | L 53 24 330 | - | L 53 24 633 | - | L 53 24 000 | - |
| 25 | 7,62 | - | - | L 53 25 332 | - | - | - | - | - | - | - | - | - | - | - |
| 26 | 7,93 | - | - | L 53 26 332 | - | - | - | - | - | - | - | - | - | - | - |
| 27 | 8,23 | - | - | L 53 27 332 | - | - | - | - | - | - | - | - | - | - | - |
| 28 | 8,54 | - | - | L 53 28 332 | - | - | - | - | - | - | - | - | - | - | - |
| 29 | 8,84 | - | - | L 53 29 332 | - | - | - | - | - | - | - | - | - | - | - |
| 30 | 9,15 | - | - | L 53 30 332 | - | - | - | - | - | - | - | - | - | - | - |
| 32 | 9,76 | - | - | L 53 32 332 | - | - | - | - | - | - | - | - | - | - | - |
| 34 | 10,37 | - | - | L 53 34 332 | - | - | - | - | - | - | - | - | - | - | - |
| 36 | 10,98 | - | - | L 53 36 332 | - | - | - | - | - | - | - | - | - | - | - |
| 38 | 11,58 | - | - | L 53 38 332 | - | - | - | - | - | - | - | - | - | - | - |

| FOTO-PICTURE | Art. SEASTAR | Art. ULTRAFLEX |
|--------------|--------------|----------------|
| | CC230 | C2 |
| | CC332 (RED) | - |
| | CC179 | C5 |
| | CC205 | C14 |
| | CC330 | C8 |
| | CCX633 | MACH0 |
| | CCX179 | MACH5 |



Timoneria meccanica G.08

- Intercambiabile con T.67 Ultraflex® e SH8050 Teleflex®
- Completo di kit mozzo 90°
- Costruito in alluminio resistente alla corrosione marina
- Costituito da una cremagliera e tre ingranaggi in alluminio (principio planetario)
- Numero giri del volante 3,5
- Diametro volante massimo 400 mm.
- Conforme alla normativa EN 29775
- Applicazione su motori fuoribordo di potenze fino a 40 Kw (55 Hp).
- Il sistema di guida G.08 con cavo C.614.05 non deve essere applicato su imbarcazioni equipaggiate con motorizzazioni che superano le potenze massime installabili stabilite dal cantiere

Mechanical steering G.08

- Interchangeable with T.67 Ultraflex® and SH8050 Teleflex®
- Packaged with 90° bezel kit
- Made of corrosion resistant material
- Made by a planetary gear design, with a central gear and three satellite gears that rotate on their axis
- Lock to lock steering wheel turns: 3,5
- Max wheel diameter 400 mm.
- Exceeds EN 29775 safety standards
- Applications for use with outboard engines up to 40 KW (55 Hp)
- Steering systems G.08 with cable C.614.05 are not to be used on boats equipped with engines that exceed the maximum horsepower rating of the boat

Articolo - Item €/pc.
L 53 85 085

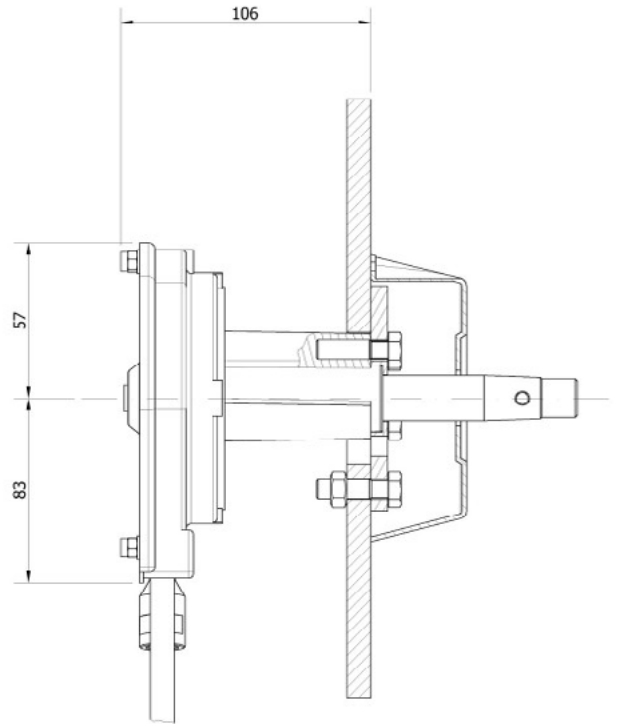

Cavo timoneria C.614.05

- Intercambiabile con M.58 Ultraflex® e SSC 1300 Teleflex®
- Corsa 230 mm.
- Estremità del cavo lato motore in acciaio inox.
- Raggio minimo di curvatura del cavo 200 mm.

Cavo modello con terminale senza filetto lato gruppo: per ordinare la sostituzione di questo tipo di cavo è fondamentale riferire la dicitura posta nella guaina nera.

Steering cable C.614.05

- Interchangeable with M.58 Ultraflex® and SSC 1300 Teleflex®
- Stroke 230 mm.
- All stainless steel output end of cable
- Minimum steering cable bend radius 200 mm.

In order to replace a not threaded terminal cable, it's important to refer the number written on the external black part of the cable.

| Piedi Feet | mt. | Articolo - Item | €/pc. |
|---------------|------|-----------------|-------|
| 8 | 2,44 | L 53 85 250 | |
| 9 | 2,75 | L 53 85 275 | |
| 10 | 3,05 | L 53 85 300 | |
| 11 | 3,36 | L 53 85 325 | |
| 12 | 3,66 | L 53 85 366 | |
| 13 | 3,97 | L 53 85 397 | |
| 14 | 4,27 | L 53 85 427 | |
| 15 | 4,59 | L 53 85 459 | |
| 16 | 4,88 | L 53 85 488 | |
| 17 | 5,19 | L 53 85 519 | |



Timoneria meccanica G.12

- Intercambiabile con T.71 Ultraflex® e SAFE-T Teleflex®
- Completo di kit mozzo 90°
- Costruito in alluminio resistente alla corrosione marina
- Costituito da una cremagliera e tre ingranaggi in alluminio (principio planetario)
- Numero giri del volante 3,8.
- Diametro volante massimo 400 mm.
- Conforme alla normativa EN 28848
- Il sistema di guida G.12 con cavo C.17.05 non deve essere applicato su imbarcazioni equipaggiate con motorizzazioni che superano le potenze massime installabili stabilite dal cantiere
- Il sistema di guida G12 è particolarmente indicato per applicazioni su imbarcazioni dotate di motori entrofuoribordo servoassistite

Mechanical steering G.12

- Interchangeable with T.71 Ultraflex® and SAFE-T Teleflex®
- Packaged with 90° bezel kit
- Made of corrosion resistant material
- Made by a planetary gear design, with a central gear and three satellite gears that rotate on their axis
- Lock to lock steering wheel turns: 3,8.
- Max wheel diameter 400 mm.
- Exceeds EN 28848 safety standards
- Steering systems G.12 with cable C.17.05 are not to be used on boats equipped with engines that exceed the maximum horsepower rating of the boat.

Articolo - Item €/pc.

L 53 71 066

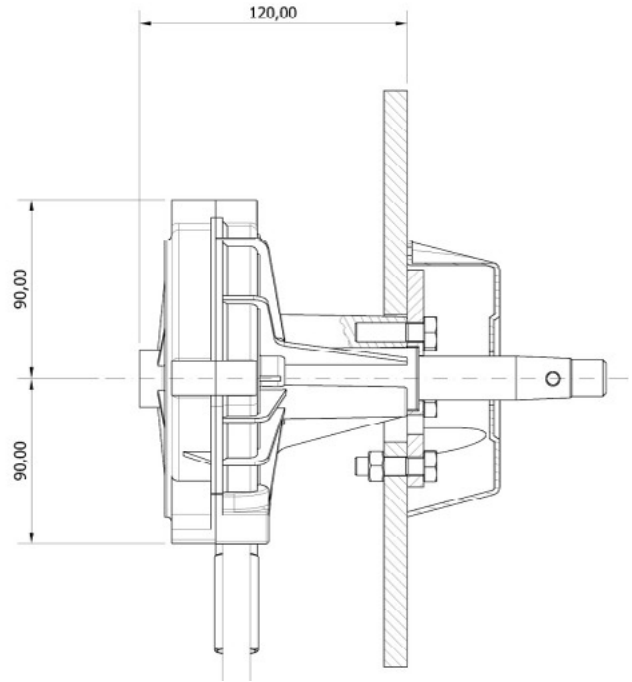

Cavo timoneria C.17.05

- Intercambiabile con M.66 Ultraflex® e SSC 62 Teleflex®
- Corsa 230 mm.
- Estremità del cavo lato motore in acciaio inox.
- Raggio minimo di curvatura del cavo 200 mm.

Steering cable C.17.05

- Interchangeable with M.66 Ultraflex® and SSC 62 Teleflex®
- Stroke 230 mm.
- All stainless steel output end of cable
- Minimum steering cable bend radius 200 mm.

| Piedi Feet | mt. | Articolo - Item | €/pc. |
|---------------|------|-----------------|-------|
| 9 | 2,75 | L 53 09 366 | |
| 10 | 3,05 | L 53 10 366 | |
| 11 | 3,36 | L 53 11 366 | |
| 12 | 3,66 | L 53 12 366 | |
| 13 | 3,97 | L 53 13 366 | |
| 14 | 4,27 | L 53 14 366 | |
| 15 | 4,59 | L 53 15 366 | |
| 16 | 4,88 | L 53 16 366 | |
| 17 | 5,19 | L 53 17 366 | |
| 18 | 5,49 | L 53 18 366 | |



Timoneria meccanica COMPAC-T

La timoneria **COMPAC-T** è adatta per l'impiego su gommoni e imbarcazioni con motori fuoribordo con potenza fino a 40 KW (53HP), motori singoli e piccole imbarcazioni da diporto.

Caratteristiche principali:

- Intercambiabile con T.67 Ultraflex® e G.08 Mavimare®
- Numero di giri volante: 2,55
- Terminali cavi in acciaio inox
- Alberino volante conico standard da 19 mm
- Installazione a 90° con coprimozzo nero già compreso nella scatola timoneria
- Conforme alle norme di sicurezza stabilite dalla A.B.Y.C.
- Conforme alle norme ISO 9775 e provviste di certificato CE

Mechanical steering system COMPAC-T

The **COMPAC-T** steering system is suitable for ribs and boats with outboard engines up to 40 KW (53HP), single engines and small leisure boats.

Main features:

- Interchangeable with T.67 Ultraflex® and G.08 Mavimare®
- Turn to turn steering wheel: 2,55
- Stainless steel terminals
- Conical wheel shaft 19 mm
- 90° installation with 90° bezel included
- In compliance with A.B.Y.C.
- In compliance with ISO 9775 with CE certification

Articolo - Item €/pc.
L 53 40 067

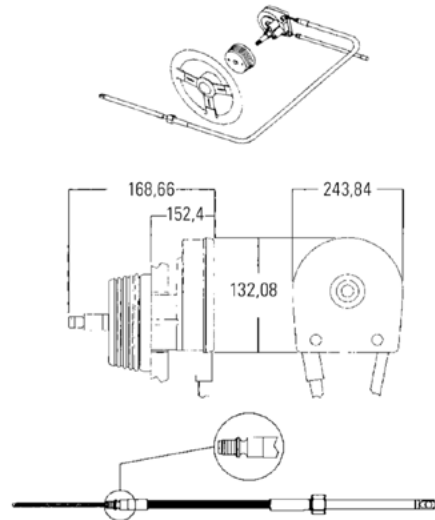

STRUMENTI DI GUIDA | STEERING

Monocavo timoneria SSC131 per timoneria COMPAC-T

Monocavo intercambiabile con M.58 Ultraflex® e C614.05 Mavimare®.

Steering cable SSC131 for steering system COMPAC-T

Interchangeable with M.58 Ultraflex® and C614.05 Mavimare®.

| Piedi Feet | mt. | Articolo - Item | €/pc. |
|---------------|------|-----------------|-------|
| 10 | 3,05 | L 53 10 131 | |
| 11 | 3,36 | L 53 11 131 | |
| 12 | 3,66 | L 53 12 131 | |
| 13 | 3,97 | L 53 13 131 | |
| 14 | 4,27 | L 53 14 131 | |
| 15 | 4,59 | L 53 15 131 | |
| 16 | 4,88 | L 53 16 131 | |
| 17 | 5,19 | L 53 17 131 | |
| 18 | 5,49 | L 53 18 131 | |
| 19 | 5,80 | L 53 19 131 | |
| 20 | 6,10 | L 53 20 131 | |



Timoneria meccanica SAFE-T QC

La timoneria **SAFE-T QC** utilizza il famoso innesto rapido brevettato che riduce sensibilmente il tempo di installazione del monocolo.
Adatta ad imbarcazioni con motorizzazioni fuoribordo, entro bordo e piedi poppieri.

Mechanical steering system SAFE-T QC

The **SAFE-T QC** steering system uses the patent pending quick connection that considerably reduces the installation time of cable.
Suitable for boats with outboard, inboard and sterndrive engines.

Caratteristiche principali:

- Intercambiabile con T71-T85 Uflex® e G.12 Mavimare®
- Innesto rapido "Quick Connect"
- Numero di giri volante: 3
- Coprimozzi a 90° per una maggiore flessibilità di montaggio (non incluso)
- Terminali cavi in acciaio inox
- Alberino volante conico standard da 19 mm
- Conforme alle norme di certificazione BIA
- Conforme alle norme di sicurezza stabilite dalla A.B.Y.C.
- Conforme alle norme ISO 8848 e provviste di certificato "CE"
- Scatola compatta con alberino volante centrale, minimo ingombro in consolle

Main features:

- Interchangeable with T71-T85 Uflex® and G.12 Mavimare®
- "Quick Connect"
- Turn to turn steering wheel: 3
- 90° bezel mounting (not included)
- Stainless steel terminals
- Conical wheel shaft 19 mm
- In compliance with BIA
- In compliance with A.B.Y.C.
- In compliance with ISO 8848 with CE certification
- Small box with central shaft

| Articolo - Item | €/pc. |
|-----------------|-------|
| L 53 12 180 | |

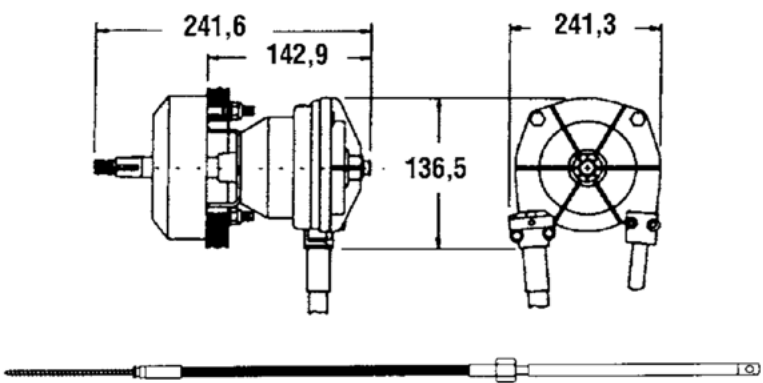

Cavo timoneria SSC62 per timoneria SAFE-T

Monocolo intercambiabile con M.66 Ultraflex® e C.17.05 Mavimare®.

Steering cable SSC62 for steering system SAFE-T

Interchangeable with M.66 Ultraflex® and C.17.05 Mavimare®.

| Piedi Feet | mt. | Articolo - Item | €/pc. |
|---------------|------|-----------------|-------|
| 10 | 3,05 | L 53 10 062 | |
| 11 | 3,36 | L 53 11 062 | |
| 12 | 3,66 | L 53 12 062 | |
| 13 | 3,97 | L 53 13 062 | |
| 14 | 4,27 | L 53 14 062 | |
| 15 | 4,59 | L 53 15 062 | |
| 16 | 4,88 | L 53 16 062 | |
| 17 | 5,19 | L 53 17 062 | |
| 18 | 5,49 | L 53 18 062 | |
| 19 | 5,80 | L 53 19 062 | |
| 20 | 6,10 | L 53 20 062 | |

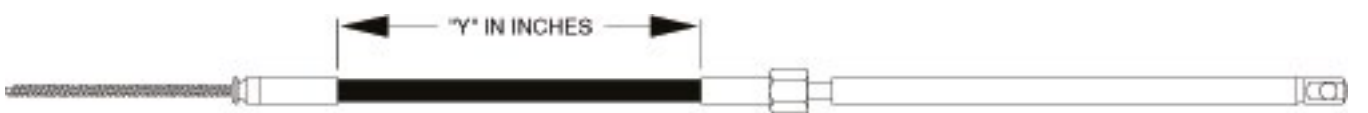

Coprimozzo 90°

90° Bezel

| Articolo - Item | €/pc. |
|-----------------|-------|
| L 53 27 484 | |



CAVI TELECOMANDI E ACCESSORI | CONTROL CABLES ACCESSORIES

Kit adattamento lato motore JOHNSON EVINRUDE

Per cavi mod. 0M.44.

Kit engine JOHNSON EVINRUDE

For fitting cable 0M.44.

Articolo - Item €/Kit
L 53 00 002



Kit adattamento lato motore VOLVO PENTA

Per cavi mod. 0M.47.

Kit engine VOLVO PENTA

For fitting cable 0M.47.

Articolo - Item €/Kit
L 53 00 047



Terminale cavo

Utilizzabile sui cavi C.042-C.048-C.MACH0.

Cable end fitting

Fits C.042-C.048-C.MACH0 fits.

Articolo - Item €/Kit
L 53 00 012



Kit adattamento lato motore JOHNSON

Per cavi mod. 0M.414.

Kit engine JOHNSON

For fitting cable 0M.414.

Articolo - Item €/Kit
L 53 00 051



Kit per adattamento cavi C.045-C.416-C.MACH45 alle scatole monoleva

Articolo - Item €/Kit
L 53 00 035



Kit for adapting cables C.045-C.416-C.MACH45 to control box

ACCESSORI PER TIMONERIE | STEERING SYSTEM ACCESSORIES

Piastrina per motori YAMAHA

Articolo - Item €/pc.
L 53 00 305



Small plate for YAMAHA engines

Giunto sferico con filetto 10MA

A richiesta è disponibile con filetto UNF3/8.

Articolo - Item €/pc.
L 53 00 580



Ball joint 10MA thread

On request is available with UNF3/8 thread.

Barra per collegare due motori fuoribordo

Utilizzabile nelle applicazioni con cilindro singolo o con cilindro doppio. Anche applicabile su tutte le doppie motorizzazioni fuoribordo con timoneria meccanica regolabile da 650 mm. a 950 mm.

Articolo - Item €/pc.
L 53 65 095



Dual outboard tie bar

Dual outboard tie bar usable in applications with one cylinder or two cylinders. The bar is applicable on all the twin outboard engines with mechanical adjustable steering from 650mm to 950mm.

Barra di rinvio Aisi 316

Regolabile per tutte le timonerie.

| Articolo - Item | €/pc. | Lunghezza Length mm. | Ø mm. |
|-----------------|-------|----------------------|-------|
| L 53 03 351 | | 380 | 11 |



Tiller Aisi 316

Barra di rinvio regolabile

Adatta per motori fuoribordo Johnson-Evinrude.

Articolo - Item €/pc.
L 53 00 232
L 53 00 160



Adjustable hinge pin

Suitable for outboard engines Johnson-Evinrude.

| Modello con attacco Connection |
|--------------------------------|
| Standard |
| Universal |

Adattatore per cavi Adapter for cables

Articolo - Item €/pc. Mod.
L 53 00 054 Cavi-Cables TX K54

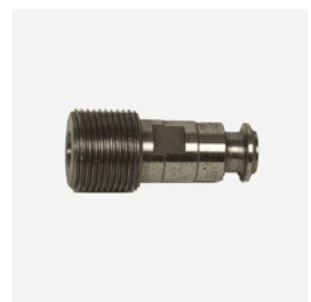

Kit timoneria idraulica per motori fuoribordo fino a 150 HP montaggio frontale

Completo di pompa, cilindro, kit raccordi, 2lt. olio.
Cilindro a montaggio frontale. Giri da banda a banda: 4,9.
Per motori Yamaha 40/50/60/70hp installare leva art.X.342.
Fornito priva di tubazioni.

Hydraulic steering system kit for outboard engines up to 150 HP

Composed of helm pump, cylinder, fittings kit, 2lt. oil.
Frontal mounting cylinder. Turns hd to hd: 4,9.
Use kit X.342 for application on Yamaha 40/50/60/70hp.
Supplied without pipes.

| Articolo - Item | €/kit | kg. |
|-----------------|-------|-----|
| L 53 00 150 | | |



Kit timoneria idraulica per motori fuoribordo fino a 300 HP montaggio frontale

Completo di pompa, cilindro, kit raccordi, 2lt. olio.
Cilindro a montaggio frontale.
Giri da banda a banda: 5.
Per motori Honda 115/130Hp installare kit L 53 00 356; per motori Mercury Optimax 115Hp installare leva art.L 53 00 340.
Forniti privi di tubazioni.

Hydraulic steering system kit for outboard engines up to 300 HP

Composed of helm pump, cylinder, fittings kit, 2lt. oil.
Frontal mounting cylinder. Turns hd to hd: 5.
Use kit L 53 00 356 for application on Honda 115/130Hp and kit L 53 00 340 for application on Mercury Optimax 115Hp.
Supplied without hoses.

| Articolo - Item | €/kit | kg. |
|-----------------|-------|-----|
| L 53 00 300 | | |



SUGGESTED ITEM



TUBAZIONI-HOSES (pag. 297)

Kit timoneria idraulica per motori entro bordo per barche da 7 a 12 mt.

Kit composto da pompa, cilindro, kit raccordi, olio.
Giri da banda a banda: 4,4.
Forniti privi di tubazioni.

Hydraulic steering system kit for inboard engines for boats from 20 to 40 ft

Kit composed of helm pump, cylinder, fittings kit, hoses and oil.
Turns hd to hd: 4,4.
Supplied without hoses.

| Articolo - Item | €/kit | kg. |
|-----------------|-------|-----|
| L 53 12 100 | | |



SUGGESTED ITEM



TUBAZIONI-HOSES (pag. 297)

Tubazioni complete di raccordi per timoneria idraulica fino a 150 HP

Con raccordi già pressati da 1/4".

Hoses set with connections for hydraulic steering up to 150 HP

With 1/4" connections.

| Articolo - Item | €/pc. | Lunghezza-Length mt. | kg. |
|-----------------|-------|----------------------|-----|
| L 53 00 366 | | 3,66 | |
| L 53 00 427 | | 4,27 | |
| L 53 00 488 | | 4,88 | |
| L 53 00 750 | | 7,50 | |



Olio idraulico Mavimare (1lt)

| Articolo - Item | €/pc. | lt. |
|-----------------|-------|-----|
| L 53 01 051 | | 1 |



Hydraulic oil Mavimare (1lt)



Soffietto bicono foro Ø 8 mm. Double cable bellows Ø 8 mm.

| Articolo - Item | €/pc. | Colore-Colour |
|-----------------|-------|----------------|
| L 53 08 080 | | ■ Nero-Black |
| L 53 08 074 | | □ Bianco-White |
| L 53 08 079 | | ■ Grigio-Grey |

NEW

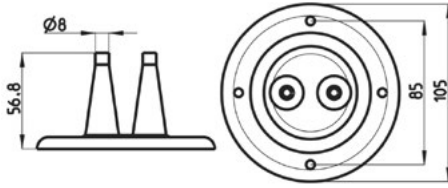

Soffietto con flangia foro Ø 12 mm. Flanged bellows Ø 12 mm.

| Articolo - Item | €/pc. | Colore-Colour |
|-----------------|-------|----------------|
| L 53 10 080 | | ■ Nero-Black |
| L 53 10 074 | | □ Bianco-White |
| L 53 10 079 | | ■ Grigio-Grey |

NEW

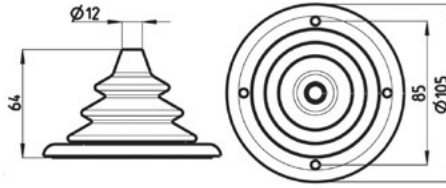

Soffietto con flangia foro Ø 12 mm. Flanged bellows Ø 12 mm.

| Articolo - Item | €/pc. | Colore-Colour |
|-----------------|-------|----------------|
| L 53 02 080 | | ■ Nero-Black |
| L 53 02 074 | | □ Bianco-White |
| L 53 02 079 | | ■ Grigio-Grey |

NEW

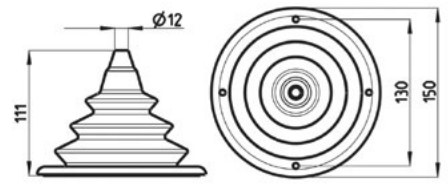

Soffietto foro Ø 8 mm. Bellows Ø 8 mm.

| Articolo - Item | €/pc. | Colore-Colour |
|-----------------|-------|----------------|
| L 53 04 080 | | ■ Nero-Black |
| L 53 04 074 | | □ Bianco-White |
| L 53 04 079 | | ■ Grigio-Grey |

NEW

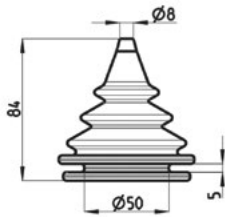

Soffietto foro Ø 11 mm. Bellows Ø 11 mm.

| Articolo - Item | €/pc. | Colore-Colour |
|-----------------|-------|----------------|
| L 53 07 080 | | ■ Nero-Black |
| L 53 07 074 | | □ Bianco-White |
| L 53 07 079 | | ■ Grigio-Grey |

NEW

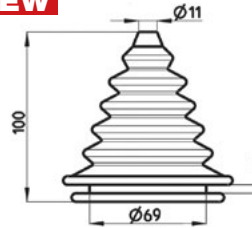

Soffietto foro Ø 11 mm. Bellows Ø 11 mm.

| Articolo - Item | €/pc. | Colore-Colour |
|-----------------|-------|----------------|
| L 53 03 080 | | ■ Nero-Black |
| L 53 03 074 | | □ Bianco-White |

NEW

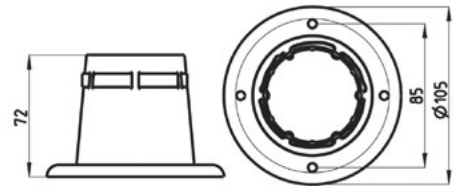

Cuffie passacavo a cono con piastra di fissaggio a vite

Fabbricate in materia plastica.

Wire steering cone with screws fixing grommet

Manufactured in plastic material.

| Articolo - Item | €/pc. | Colore-Colour | Ø mm. | H mm. | kg. |
|-----------------|-------|----------------|-------|-------|-----|
| L 53 09 074 | | □ Bianco-White | 90 | 100 | |
| L 53 09 080 | | ■ Nero-Black | 90 | 100 | |

NEW



Kit protezione cavi grigio

Sistema con boccola tubo spiralato e terminale di protezione per i cavi elettrici e di servizio dei motori fuoribordo.

Cable protection kit grey

System with spiral pipe and fittings included for excellent protection of electric control and steering cables of outboard engines.

| Articolo - Item | €/pc. | Lunghezza Length mm. | Foro vetroresina Hole Ø mm. | Ø interno tubo Pipe inner Ø mm. | kg. |
|-----------------|-------|----------------------|-----------------------------|---------------------------------|-------|
| L 53 50 800 | | 800 | 70 | 50 | 0,500 |
| L 53 50 100 | | 1000 | 70 | 50 | 0,500 |



COMPLETO DI-COMLETE WITH



Art. P1600062 (pag. 299)

Art. L5362100 (pag. 299)

Art. L5300100 (pag. 299)

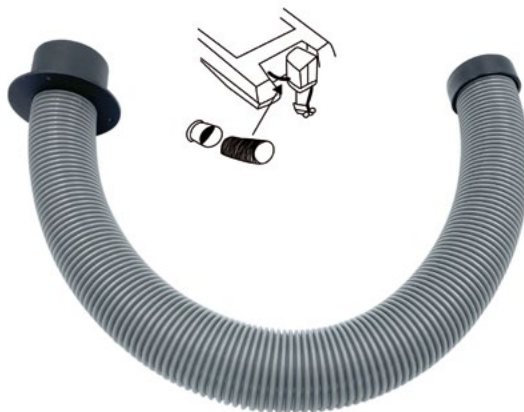

Kit protezione cavi nero

Con boccola passacavo e attacco flangia per protezione cavi elettrici.

Cable protection kit black

System with spiral pipe and fittings included for excellent protection of electric control and steering cables of outboard engines.

| Articolo - Item | €/pc. | Lunghezza Length mm. | Foro vetroresina Hole Ø mm. | Ø interno tubo Pipe inner Ø mm. | kg. |
|-----------------|-------|----------------------|-----------------------------|---------------------------------|-------|
| L 53 05 080 | | 800 | 70 | 50 | 0,500 |
| L 53 05 100 | | 1000 | 70 | 50 | 0,500 |



COMPLETO DI-COMLETE WITH



Art. P 1680062 (pag. 299)

Art. L5362100 (pag. 299)

Art. L5300100 (pag. 299)



Tubo flessibile in PVC

Tubo spiralato che protegge da polvere, abrasioni e agenti atmosferici.

PVC flexible hose

Spiral pipe for cable protection.

| Articolo - Item | €/mt. | € / 15mt. | Ø mm. | Colore Colour | mt. | kg. |
|------------------------|-------|-----------|-------|---------------|-----|-------|
| P 16 00 062 | | | 53-62 | Grigio-Grey | 15 | 5,300 |
| P 16 80 062 NEW | | | 53-62 | Nero-Black | 15 | 5,300 |



SUGGESTED ITEM



Art. L5362100

Art. L5300100



Attacco flangia per tubo protezione cavi

Colore nero.

Flange joint for cable protection kit

Black colour.

| Articolo - Item | €/pc. | €/Box | Ø esterno mm. Outer Ø mm. | Ø Scasso mm. |
|-----------------|-------|-------|---------------------------|--------------|
| L 53 62 100 | | | 100 | 70 |

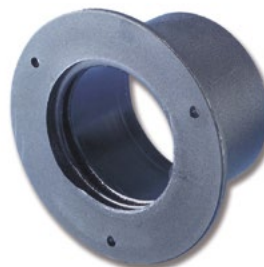

Terminale passacavo per tubo protezione cavi

Colore nero.

End joint for cable protection kit

Black colour.

| Articolo - Item | €/pc. | €/Box | Ø esterno mm. Outer Ø mm. |
|-----------------|-------|-------|---------------------------|
| L 53 00 100 | | | 70 |





Bussola montaggio in piano serie «C3»

- Ideale per dinghy e gommoni. Montaggio in piano. Di facile lettura, sia da seduti che in piedi.
- Quadrante Ø 65 mm.
 - Card design: conico
 - Illuminazione notturna: 12-24V
 - Compensatori: NO
 - Garanzia 2 anni

Surface mount compass «C3»

- Ideally suited for use in a RIB or dinghy. Flat surface mounting. Easy to read when standing up or sitting down.
- Dial Ø 65 mm.
 - Card design: conical
 - Night lightning: 12-24V
 - Compensators: NO
 - Warranty 2 years

| Articolo - Item | €/pc. | Colore Colour | Mod. |
|-----------------|-------|---------------|------|
| L 45 03 074 | | Bianco-White | C3 |
| L 45 80 003 | | Nero-Black | C3 |

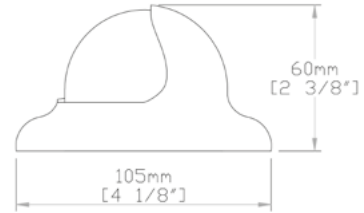

Bussola a incasso colore nero serie «C12» 110 series

- Ideale per montaggio su quadri. Di facile e chiara lettura.
- Per barche a vela e motore
 - Quadrante Ø 85 mm.
 - Card design: piatto o conico
 - Illuminazione notturna: 12-24V
 - Compensatori: NO
 - Foro di montaggio 85 mm.
 - Garanzia 5 anni
 - Omologazione N. MED200319CS/002

Black colour flush mount compass «C12» 110 series

- Mounting on horizontal surface. Easy reading.
- Sail & power boats
 - Dial Ø 85 mm.
 - Card design: flat or conical
 - Night lightning: 12-24V
 - Compensators: NO
 - Mounting hole 85 mm.
 - Warranty 5 years
 - Homologation N. MED200319CS/002

| Articolo - Item | €/pc. | Colore Colour | Mod. |
|-----------------|-------|---------------|----------------|
| L 45 12 080 | | Nero-Black | C12 110 SERIES |

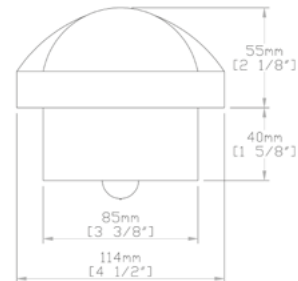

Bussola montaggio in piano colore nero serie «C15»

- Per montaggio in piano. Di facile e chiara lettura.
- Per barche a vela e motore
 - Quadrante Ø 100 mm.
 - Card design: piatto o conico
 - Illuminazione notturna: 12-24V
 - Compensatori: incorporati
 - Cover protettiva compresa
 - Garanzia 5 anni
 - Omologazione N. MED200319CS/002

Black colour deck mount compass «C15»

- Deck mounting. Easy reading.
- Sail & power boats
 - Dial Ø 100 mm.
 - Card design: flat or conical
 - Night lightning: 12-24V
 - Compensators: built-in
 - Protection cover: YES
 - Warranty 5 years
 - Homologation N. MED200319CS/002

| Articolo - Item | €/pc. | Colore Colour | Mod. |
|-----------------|-------|---------------|------|
| L 45 15 080 | | Nero-Black | C15 |

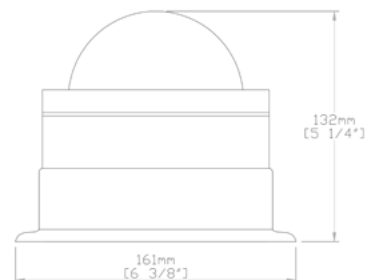



Bussola montaggio a incasso
serie «C15» 150 series

- Montaggio a incasso
- Per barche a vela e motore
- Quadrante Ø 100 mm.
- Card design: piatto o conico
- Illuminazione notturna: 12-24V
- Cover protettiva compresca
- Compensatori: NO
- Foro di montaggio 85 mm.
- Garanzia 5 anni
- Omologazione N. MED200319CS/002

Flush mount compass
«C15» 150 series

- Flush mounting
- Sail & power boats
- Dial Ø 100 mm.
- Card design: flat or conical
- Night lightning: 12-24V
- Protection cover: YES
- Compensators: NO
- Mounting hole 85 mm.
- Warranty 5 years
- Homologation N. MED200319CS/002

| Articolo - Item | €/pc. | Colore Colour | Mod. |
|-----------------|-------|------------------|------|
| L 45 15 174 | | □ Bianco-White | C15 |
| L 45 15 180 | | ■ Nero-Black | C15 |

SOLAS HOMOLOGATED CE 12-24V **NEW**

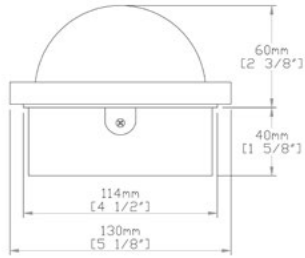

Bussola montaggio in piano
serie «CHE»

- Ideale per la pesca.
- Montaggio in piano
 - Per barche a vela e motore
 - Quadrante Ø 140 mm.
 - Card design: piatto
 - Illuminazione notturna: 12-24V
 - Cover protettiva compresca
 - Compensatori: incorporati
 - Garanzia 5 anni
 - Omologazione N. MED200319CS/002

Deck mount compass
«CHE» series

- Ideally suited for fishing.
- Deck mounting
 - Sail & power boats
 - Dial Ø 140 mm.
 - Card design: flat
 - Night lightning: 12-24V
 - Protection cover: YES
 - Compensators: built-in
 - Warranty 5 years
 - Homologation N. MED200319CS/002

| Articolo - Item | €/pc. | Colore Colour | Mod. |
|-----------------|-------|------------------|------|
| L 45 73 080 | | ■ Nero-Black | CHE |

SOLAS HOMOLOGATED CE 12-24V **NEW**

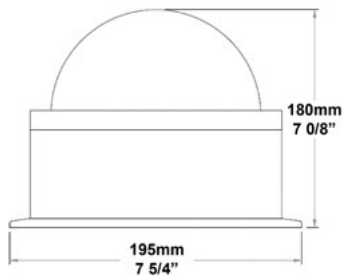

Bussola «RITCHIE» Explorer 2" 3/4 (70 mm) con compensatori e luce

Compass «RITCHIE» Explorer 2" 3/4 (70 mm) with built-in compensators and back light

| Articolo - Item | €/pc. | Versione montaggio Mounting version | Illuminazione-Lightning LED 12V | Corpo Body | Rosa Bulb |
|-----------------|-------|--|------------------------------------|---------------|--------------|
| L 45 95 050 | | Incasso-Flush mount | SI-YES | ■ Nero-Black | ■ Nero-Black |
| L 45 95 057 | | Verticale-Dash mount | SI-YES | ■ Nero-Black | ■ Nero-Black |
| L 45 62 450 | | In piano-Deck mount | SI-YES | ■ Nero-Black | ■ Nero-Black |
| L 45 70 450 | | Con staffa-Bracket mount | SI-YES | ■ Nero-Black | ■ Nero-Black |

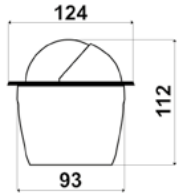

L4595050

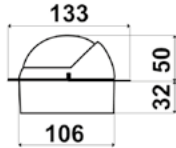

L4595057

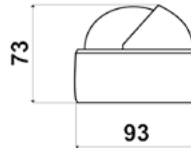

L4562450

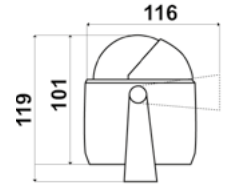

L4570450



Bussola «RITCHIE» Voyager 3" (76 mm) con compensatori e luce

Compass «RITCHIE» Voyager 3" (76 mm) with built-in compensators and back light

| Articolo - Item | €/pc. | Versione lettura Reading version | Illuminazione-Lightning LED 12V | Corpo Body | Rosa Bulb |
|-----------------|-------|-------------------------------------|------------------------------------|---------------|--------------|
| L 45 95 082 | | In piano-Surface mount | SI-YES | ■ Nero-Black | ■ Nero-Black |
| L 45 95 083 | | Frontale-Front reading | SI-YES | ■ Nero-Black | ■ Nero-Black |

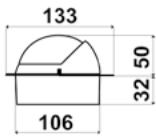

L4595082

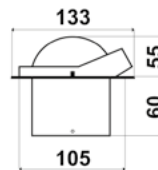

L4595083



Bussola «Sport» da rilevamento 1" 7/8

Modello con protezione antiurto.
Completa di cima.
Stima di lettura 0,5°.

Bearing compass «Sport» 1" 7/8

Provided with shockproof system.
With line.
Reading estimate 0,5°.

| Articolo - Item | €/pc. | Mod. | Bulb Ø mm. |
|-----------------|-------|------------|------------|
| L 45 48 170 | | X - 11 - Y | 48 |



Bussola con supporto a staffa Ø 2" - 3"

Realizzata in materia plastica. Retroilluminata.

| Articolo - Item | €/pc. | Ø |
|-----------------|-------|----|
| L 45 70 031 | | 2" |
| L 48 70 031 | | 2" |
| L 45 70 032 | | 3" |
| L 48 70 032 | | 3" |

Bracket mount compass ø 2" - 3"

Made in plastic material. Backlight.

| ↑ mm. | Colore - Colour | kg. |
|--------------|-----------------|-------|
| Ø 55 x 80 H | ■ Nero-Black | 0,080 |
| Ø 55 x 80 H | □ Bianco-White | 0,080 |
| Ø 78 x 130 H | ■ Nero-Black | 0,260 |
| Ø 78 x 130 H | □ Bianco-White | 0,260 |



L4570031



L4870031



L4570032-L4870032

Bussola a staffa Ø 2"

Scala di 5°. Linea di fede a grande visibilità. Lettura frontale.

Bracket mount compass ø 2"

Rose apparent Ø 50 mm. Graduated every 5°. Front reading.

| Articolo - Item | €/pc. | Bulbo-Bulb Ø mm. | Colore - Colour | kg. |
|-----------------|-------|------------------|-----------------|-------|
| L 45 05 030 | | 50 | ■ Nero-Black | 0,130 |



Bussola a ventosa Ø 2"

Realizzata in materia plastica. Sistema di compensazione ultrasensibile. Regolabile.

Compass ø 2" vacuum cup mounting

Apparent 50 mm. Graduated every 5°. Adjustable.

| Articolo - Item | €/pc. | ↑ mm. | Colore - Colour | kg. |
|-----------------|-------|-------|-----------------|-------|
| L 48 70 030 | | 55x55 | □ Bianco-White | 0,050 |
| L 45 70 030 | | 55x55 | ■ Nero-Black | 0,050 |



Bussola di rilevamento «Standard»

Provvista di lente di ingrandimento con doppia scala. Stabilissima, lettura molto chiara. Ideale per piccole imbarcazioni e canotti.

Bearing compass «Standard»

Provided with magnification lens with double scale. Very easy reading. For small boats and inflatables.

| Articolo - Item | €/pc. | Quadrante-Dial Ø mm. | kg. |
|-----------------|-------|----------------------|-------|
| L 25 35 135 | | 45 | 0,070 |



Bussola di rilevamento con scalimetro

Provvista di scalimetro laterale, lente di ingrandimento con lettura notturna molto chiara. Doppia scala in gradi e rombi.

Bearing compass with scale meter

With side scale meter. Provided with magnification lens with double scale. Very easy reading.

| Articolo - Item | €/pc. | Quadrante-Dial Ø mm. | kg. |
|-----------------|-------|----------------------|-------|
| L 25 03 017 | | 45 | 0,080 |

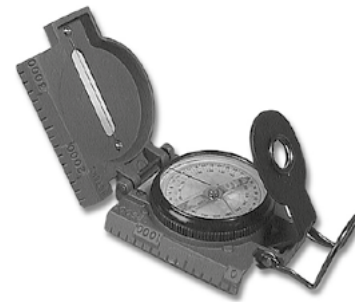

ANEMOMETRI | ANEMOMETERS

Anemometro Skywatch Xplorer 1

Visualizzazione velocità del vento in km/h, mph, m/s, fps e nodi. Velocità del vento attuale e quella massima. Quadro retroilluminato.

| Articolo - Item | €/pc. | mm. | kg. |
|-----------------|-------|----------|-------|
| L 46 20 003 | | 41x93x17 | 0,050 |



Anemometer Skywatch Xplorer 1

5 measurement units : km/h, mph, knots, m/s and fps. 3 wind measurement modes: instant, maximum and average. Backlight.

Anemometro-Termometro Skywatch Xplorer 2

Visualizzazione velocità del vento in km/h, mph, m/s, fps e nodi. Velocità del vento attuale e quella massima. Temperatura ambiente (range: -40°C +80°C). Misura il fattore wind chill (temperatura percepita dalla persona). Quadro retroilluminato.

| Articolo - Item | €/pc. | mm. | kg. |
|-----------------|-------|----------|-------|
| L 46 42 004 | | 41x93x17 | 0,050 |



Anemometro-Termometro Skywatch Xplorer 3

Con bussola elettronica. Visualizzazione velocità del vento in km/h, mph, m/s, fps e nodi. Velocità del vento attuale e quella massima. Temperatura ambiente (range: -40°C +80°C). Misura il fattore wind chill (temperatura percepita dalla persona). Bussola elettronica con indicazione del rilevamento in gradi. Quadro retroilluminato.

| Articolo - Item | €/pc. | mm. | kg. |
|-----------------|-------|----------|-------|
| L 46 22 003 | | 41x93x17 | 0,050 |



Anemometer-Thermometer Skywatch Xplorer 3

Electronic compass in degrees. 5 measurement units : km/h, mph, knots, m/s and fps. 3 wind measurement modes : instant, maximum and average. Backlight. Operation Temperature -40°C to 80°C. Balanced instant windspeed. Calculation of the wind chill factor.

Anemometro per smartphone

Questo anemometro per smartphone è stato calibrato nel dipartimento di Ingegneria Aerospaziale dell'Università della Florida e presenta un errore massimo del 0,5% (per misurazioni fino a un massimo del 15% fuori asse).

| Articolo - Item | €/pc. | kg. |
|-----------------|-------|-------|
| L 46 22 015 | | 0,050 |



WeatherFlow Wind Meter

This Anemometer for smartphones has been gauged in the Department of Aerospace Engineering of the University of Florida and presents a maximum error of 0,5% (for measurements up to max 15% out of axis).

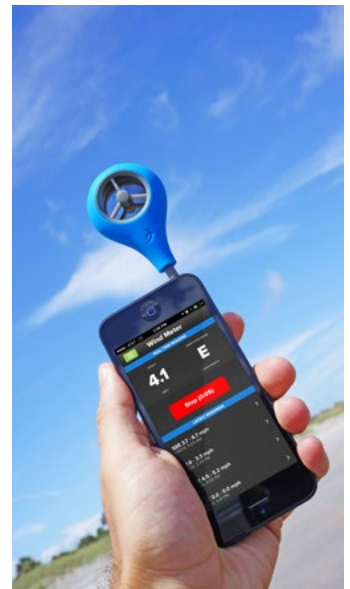

VHF portatile HH125 EU+

VHF resistente all'acqua cat. IPX4. L'ampio display, l'impugnatura confortevole e le funzioni allocate in modo pertinente su specifici tasti, rendono l'HH125 particolarmente semplice da usare e consentono di poter sfruttare al meglio funzionalità come la memorizzazione dei canali "preferiti", la visualizzazione della barra di ricezione del segnale, lo stato di carica della batteria, il Roger Beep e il blocco della tastiera. Funzione di Dual Watch (scansione del Canale 16+1 a scelta), indicatore dell'intensità del segnale, tasto riservato per canale 16, potenza di trasmissione fino a 3 Watt. Alimentazione tramite 5 batterie ministolto ricaricabili (comprese). Dim. 62x31x102H mm.

Portable VHF HH125 EU+

The Cobra HH125 is a fully featured VHF radio with a rugged compact design. It's perfect for recreational boaters or as a portable backup on larger vessels. It comes standard with a removable spring loaded belt clip, lanyard and DC cigarette lighter charger. Anyone who lives, works or plays on the water needs one of these VHF radios. It is packaged with long-lasting rechargeable NiMH batteries that won't develop a memory when charging. It can also be used with 5 standard AAA alkaline batteries in emergencies. The backlit LCD and keypad allows it to be used in low light conditions and will turn off automatically to conserve battery power. Size 62x31x102H mm.



| | |
|-----------------|-------|
| Articolo - Item | €/pc. |
| L 31 02 125 | |



VHF portatile HH350 FLT EU

VHF galleggiante, con banda arancione ad alta visibilità, trasmette con una potenza fino a 6 Watt. Dotato della funzione Burp che fa espellere la possibile condensa presente sull'altoparlante tramite la griglia di protezione facendogli emettere all'altoparlante un tono di frequenza molto bassa, del Roger Beep che indica la fine trasmissione e di conseguenza la possibilità di parlare. Funzione Noise Cancelling che permette di trasmettere un segnale pulito dai rumori ambientali, la Barra di Intensità del segnale in Rx a 5 tacche e i toni di chiamata per farsi riconoscere dal ricevente. L'antennino è stato dotato di connettore SMA ed è quindi ora removibile per rendere più agevole lo stivaggio. Funzione tri-watch (scansione del canale 16 + 2 a scelta), tasto riservato al canale 16 e 9, batteria ricaricabile 1000 mAh. Dim. mm. antenna esclusa 62x36x123H mm. Peso 272 gr.

Portable VHF HH350 FLT EU

The best value in our handheld VHF radio line up! Backed by 50 years of Cobra quality, this floating radio has an orange core for higher visibility and is easy to retrieve if dropped overboard. It features 6 Watts of power for longer range communications and full access to all NOAA weather channels and alarm tones for weather emergencies. It also includes all of the core features like Noise canceling microphone, JIS7/IPX7 rated Submersible, Tri-Watch, Memory Channels, Memory Scan and BURP. Size (antenna excluded) 62x36x123H mm. Weight 272 gr.



| | |
|-----------------|-------|
| Articolo - Item | €/pc. |
| L 31 20 350 | |



VHF portatile MR HH500 FLT BT EU

Galleggiante, stagno Ipx7 con funzionalità Microblue Bluetooth che consente di tenere il telefonino in un posto sicuro ed usare il VHF anche per la gestione delle telefonate in ingresso ed uscita e Rewind Say Again che consente di riascoltare tutte le eventuali chiamate perse. Funzione Noise Cancelling che consente di trasmettere la voce in modo limpido e pulito. Dotato delle caratteristiche peculiari di Cobra Marine quali funzione Burp, il Roger Beep, la Barra di Intensità del segnale ed i toni di chiamata. L'antennino è stato dotato di connettore SMA ed è quindi ora removibile per rendere più agevole lo stivaggio. Funzione tri-watch (scansione del canale 16 + 2 a scelta), tasto riservato al canale 16 e 9, potenza di trasmissione fino a 6 watt, batteria ricaricabile 1000 mAh. Dim. 67x53x121H mm.

Portable VHF MR HH500 FLT BT EU

The best value in our handheld VHF radio line up! Backed by 50 years of Cobra quality, this floating radio has an orange core for higher visibility and is easy to retrieve if dropped overboard. It features 6 Watts of power for longer range communications and full access to all NOAA weather channels and alarm tones for weather emergencies. It also includes all of the core features like Noise canceling microphone, JIS7/IPX7 rated Submersible, Tri-Watch, Memory Channels, Memory Scan and BURP. Size 67x53x121H mm.



| | |
|-----------------|-------|
| Articolo - Item | €/pc. |
| L 31 20 500 | |



VHF FISSI | FIXED MOUNT VHF

VHF fisso MR F57

VHF con funzione Automatic Radio Check che consente di effettuare un controllo del voltaggio delle batterie in trasmissione, della potenza di trasmissione RF e del funzionamento dell'antenna. Possibilità di ri-ascolto di un messaggio con la funzione Rewind Say Again. Ingresso NMEA sia per GPS primario che secondario ed uscita NMEA per mostrare sul GPS nautico le imbarcazioni che hanno generato una comunicazione DSC. Inoltre tramite l'ingresso NMEA potremo utilizzare il VHF come diffusore acustico di allarmi provenienti da altri dispositivi. In dotazione è presente il kit di installazione per l'incasso e quello per staffa. Stagno Ipx7. Dim. 159x180x57H mm.

Fixed mount VHF MR F57

Included is Cobra's exclusive Rewind-Say-Again® digital voice recorder, Plug N Play External GPS receiver capable (using the optional Cobra C.P.S. CM 300-005), 4 softkeys positioned at the bottom of the LCD to allow the user to easily activate and navigate through menus. NOAA Weather Radio, Weather Alert, providing 24 hour access to audio broadcasts and Emergency Alerts to keep boaters safe and informed, IPX8/JIS8 Submersible, Instant channel 16/9, Scan, PA (Public Address) speaker output, External speaker output, Illuminated LCD, Signal strength meter (for radio receiver and external GPS receiver), etc. Size 159x180x57H mm.



| Articolo - Item | €/pc. | Colore-Colour | GPS | Alimentazione-Power |
|-----------------|-------|----------------|------------|---------------------|
| L 31 80 057 | | ■ Nero-Black | Assente-NO | 12VDC |
| L 31 74 057 | | □ Bianco-White | Assente-NO | 12VDC |



VHF fisso MR F77

VHF fisso progettato appositamente per offrire la migliore sicurezza nelle chiamate DSC grazie ad un GPS integrato. La funzione Automatic Radio Check consente di verificare il corretto funzionamento della batteria di bordo, della potenza di trasmissione e dell'antenna. Mentre la funzione Rewind Say Again permette di riascoltare. L'NMEA IN è utilizzabile per un GPS secondario o per operare come segnalatore di allarmi. Mentre l'NMEA OUT consente di segnalare su un plotter le imbarcazioni coinvolte in una chiamata DSC. Stagno Ipx7. In dotazione è presente il kit di installazione per l'incasso e quello per staffa. Dim. 159x18 x57H mm.

Fixed mount VHF MR F77

The Cobra MR F77 is a truly unique VHF radio with its large LCD display and an integrated GPS receiver making the radio ready out of the box to be a complete life saving solution. Included is Cobra's exclusive Rewind-Say-Again® digital voice recorder, 4 softkeys positioned at the bottom of the LCD to allow the user to easily activate and navigate through menus. External speaker output, Illuminated LCD, Signal strength meter (for radio receiver and GPS receiver), etc. Compliant with the latest FCC specifications for Class-D VHF radios. Size 159x18 x57H mm.



| Articolo - Item | €/pc. | Colore-Colour | GPS | Alimentazione-Power |
|-----------------|-------|----------------|------------------|---------------------|
| L 31 80 075 | | ■ Nero-Black | Interno-Built-in | 12VDC |
| L 31 74 075 | | □ Bianco-White | Interno-Built-in | 12VDC |



Antenna VHF

Connessione FASTFIT.

VHF Antenna

FASTFIT Connection.

| Articolo - Item | €/pc. |
|-----------------|-------|
| L 31 01 119 | |

**Caratteristiche tecniche - Technical features**

| | |
|---------------------------------|--------------------|
| Tipologia-Type | Antenna |
| Banda | VHF |
| Frequenza-Frequency | 156-162 Mhz |
| Lunghezza-Length mt. | 1,50 |
| Mancione | Nylon |
| Tipo-Type | Fiberglass Whip |
| Finitura-Finishing | Polyurethane paint |
| Colore-Colour | Bianco-White |
| Peso-Weight kg. | 0,30 |
| Guadagno-Gain | 3 |
| Sezioni-Sections | 1 |
| Montaggio-Mounting | Nylon |
| Cavo/Connettore-Cable/Connector | Fastfit |
| S.W.R. | Less than 1,5 |
| Impedenza-Impedance | 50 Ohm |
| Polarizzazione | Vertical |
| Max potenza-Max power | 25 |
| Protezione anifulmine | SI-YES |
| Cortocircuitata a massa | SI-YES |

**SUGGESTED ITEM**

Art. L3109054
(pag. 309)

Antenna VHF**VHF Antenna**

| Articolo - Item | €/pc. |
|-----------------|-------|
| L 31 00 353 | |

**Caratteristiche tecniche - Technical features**

| | |
|---------------------------------|--------------------|
| Tipologia-Type | Antenna |
| Banda | VHF |
| Frequenza-Frequency | 156-162 Mhz |
| Lunghezza-Length mt. | 1,20 |
| Mancione | Nylon |
| Tipo-Type | Fiberglass Whip |
| Finitura-Finishing | Polyurethane paint |
| Colore-Colour | Bianco-White |
| Peso-Weight kg. | 0,29 |
| Guadagno-Gain | 3 |
| Sezioni-Sections | 1 |
| Montaggio-Mounting | 1"-14 female |
| Cavo/Connettore-Cable/Connector | 5,00 mt. RG 58 |
| S.W.R. | Less than 1,5 |
| Impedenza-Impedance | 50 Ohm |
| Polarizzazione | Vertical |
| Max potenza-Max power | 25 |
| Protezione anifulmine | SI-YES |
| Cortocircuitata a massa | SI-YES |

SUGGESTED ITEM

BASI ANTENNA
ANTENNA BASES
(pag. 309)

**Antenna VHF****VHF Antenna**

| Articolo - Item | €/pc. |
|-----------------|-------|
| L 31 00 119 | |

**Caratteristiche tecniche - Technical features**

| | |
|---------------------------------|--------------------|
| Tipologia-Type | Antenna |
| Banda | VHF |
| Frequenza-Frequency | 156-162 Mhz |
| Lunghezza-Length mt. | 1,50 |
| Mancione | Nylon |
| Tipo-Type | Fiberglass Whip |
| Finitura-Finishing | Polyurethane paint |
| Colore-Colour | Bianco-White |
| Peso-Weight kg. | 0,40 |
| Guadagno-Gain | 3 |
| Sezioni-Sections | 1 |
| Montaggio-Mounting | 1"-14 female |
| Cavo/Connettore-Cable/Connector | 5,00 mt. RG 58 |
| S.W.R. | Less than 1,5 |
| Impedenza-Impedance | 50 Ohm |
| Polarizzazione | Vertical |
| Max potenza-Max power | 25 |
| Protezione anifulmine | SI-YES |
| Cortocircuitata a massa | SI-YES |

SUGGESTED ITEM

Art. L3100054
(pag. 309)

**Antenna VHF****VHF Antenna**

| Articolo - Item | €/pc. |
|-----------------|-------|
| L 31 00 158 | |

**Caratteristiche tecniche - Technical features**

| | |
|---------------------------------|--------------------|
| Tipologia-Type | Antenna |
| Banda | VHF |
| Frequenza-Frequency | 156-162 Mhz |
| Lunghezza-Length mt. | 1,00 |
| Mancione | Nylon |
| Tipo-Type | S/S Whip |
| Finitura-Finishing | Polyurethane paint |
| Colore-Colour | Bianco-White |
| Peso-Weight kg. | 0,30 |
| Guadagno-Gain | 3 |
| Sezioni-Sections | 1 |
| Montaggio-Mounting | Alu L bracket |
| Cavo/Connettore-Cable/Connector | 18,00 mt. RG 58 |
| S.W.R. | Less than 1,1 |
| Impedenza-Impedance | 50 Ohm |
| Polarizzazione | Vertical |
| Max potenza-Max power | 25 |
| Protezione anifulmine | SI-YES |
| Cortocircuitata a massa | SI-YES |

SUGGESTED ITEM

Antenna VHF

VHF Antenna

Articolo - Item €/pc.
L 31 08 264



Caratteristiche tecniche - Technical features

| | |
|---------------------------------|--------------------|
| Tipologia-Type | Antenna |
| Banda | VHF |
| Frequenza-Frequency | 156-162 Mhz |
| Lunghezza-Length mt. | 2,50 |
| Mancione | Nylon |
| Tipo-Type | Fiberglass Whip |
| Finitura-Finishing | Polyurethane paint |
| Colore-Colour | Bianco-White |
| Peso-Weight kg. | 0,50 |
| Guadagno-Gain | 6 |
| Sezioni-Sections | 1 |
| Montaggio-Mounting | 1"-14 female |
| Cavo/Connettore-Cable/Connector | 5,00 mt. RG 58 |
| S.W.R. | Less than 1,3 |
| Impedenza-Impedance | 50 Ohm |
| Polarizzazione | Vertical |
| Max potenza-Max power | 25 |
| Protezione anifulmine | SI-YES |
| Cortocircuitata a massa | SI-YES |



SUGGESTED ITEM



BASI ANTENNA
ANTENNA BASES
(pag. 309)

Antenna AM/FM

AM/FM Antenna

Articolo - Item €/pc.
L 31 81 030



Caratteristiche tecniche - Technical features

| | |
|---------------------------------|--------------------|
| Tipologia-Type | Antenna |
| Banda | AM FM |
| Frequenza-Frequency | AM FM |
| Lunghezza-Length mt. | 0,25 |
| Mancione | Ottone cromato |
| Tipo-Type | Fiberglass Whip |
| Finitura-Finishing | Polyurethane paint |
| Colore-Colour | Bianco-White |
| Peso-Weight kg. | 0,11 |
| Guadagno-Gain | - |
| Sezioni-Sections | 1 |
| Montaggio-Mounting | Flangia-On flange |
| Cavo/Connettore-Cable/Connector | F Connector |
| S.W.R. | - |
| Impedenza-Impedance | - |
| Polarizzazione | - |
| Max potenza-Max power | - |
| Protezione anifulmine | SI-YES |
| Cortocircuitata a massa | SI-YES |



Antenna GSM

GSM Antenna

Articolo - Item €/pc.
L 31 00 160



Caratteristiche tecniche - Technical features

| | |
|---------------------------------|---|
| Tipologia-Type | Antenna |
| Banda | GSM UMTS |
| Frequenza-Frequency | 806-900 / 840-940 / 1800-1710 / 1900-1990 / 1920-2170-2600 Mhz GSM+GPRS+UMTS+LTE |
| Lunghezza-Length mt. | 0,25 |
| Mancione | Ottone cromato |
| Tipo-Type | Fiberglass Whip |
| Finitura-Finishing | Polyurethane paint |
| Colore-Colour | Bianco-White |
| Peso-Weight kg. | 0,31 |
| Guadagno-Gain | 3 |
| Sezioni-Sections | 1 |
| Montaggio-Mounting | Navy |
| Cavo/Connettore-Cable/Connector | N Connector |
| S.W.R. | - |
| Impedenza-Impedance | - |
| Polarizzazione | - |
| Max potenza-Max power | - |
| Protezione anifulmine | SI-YES |
| Cortocircuitata a massa | SI-YES |



Antenna VHF

VHF Antenna

Articolo - Item €/pc.
L 31 05 165



Caratteristiche tecniche - Technical features

| | |
|---------------------------------|--------------------|
| Tipologia-Type | Antenna |
| Banda | VHF |
| Frequenza-Frequency | 156-162 Mhz |
| Lunghezza-Length mt. | 1,50 |
| Mancione | Nylon |
| Tipo-Type | Fiberglass Whip |
| Finitura-Finishing | Polyurethane paint |
| Colore-Colour | Bianco-White |
| Peso-Weight kg. | 0,60 |
| Guadagno-Gain | 3 |
| Sezioni-Sections | 1 |
| Montaggio-Mounting | 1"-14 female |
| Cavo/Connettore-Cable/Connector | 5,00 mt. RG 58 |
| S.W.R. | Less than 1,5 |
| Impedenza-Impedance | 50 Ohm |
| Polarizzazione | Vertical |
| Max potenza-Max power | 25 |
| Protezione anifulmine | SI-YES |
| Cortocircuitata a massa | SI-YES |

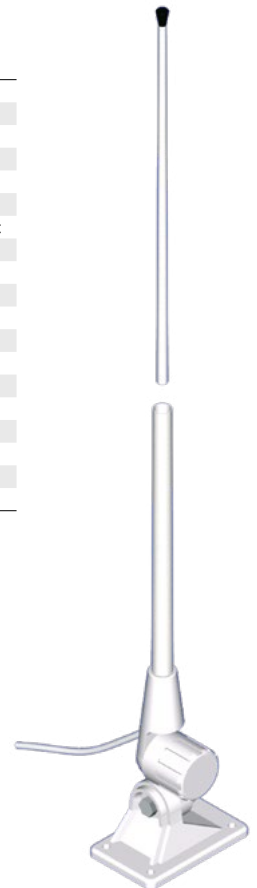

ANTENNE | ANTENNAS

Antenna TV

TV Antenna

Articolo - Item €/pc.
L 31 00 250



Caratteristiche tecniche - Technical features

| | |
|---------------------------------|-------------------|
| Tipologia-Type | Antenna |
| Banda | TV DVB-T |
| Ø cm. | 25 |
| Mancione | Plastic |
| Tipo-Type | Disc Radome |
| Colore-Colour | Bianco-White |
| Peso-Weight kg. | 0,38 |
| Guadagno-Gain | 26 |
| Montaggio-Mounting | Tubo-Pipe Ø 24 mm |
| Cavo/Connettore-Cable/Connector | F Connector |

COMPLETE WITH



Antenna TV

TV Antenna

Articolo - Item €/pc.
L 31 00 335



Caratteristiche tecniche - Technical features

| | |
|---------------------------------|----------------------------------|
| Tipologia-Type | Antenna |
| Banda | TV DVB-T |
| Lunghezza-Length mt. | 0,20 |
| Mancione | Plastic |
| Tipo-Type | Plastic Radome |
| Colore-Colour | Bianco-White |
| Peso-Weight kg. | 1,05 |
| Guadagno-Gain | 26 |
| Montaggio-Mounting | 1"-14 female |
| Cavo/Connettore-Cable/Connector | F Connector + 15,00 mt. Cable |



Antenna TV

TV Antenna

Articolo - Item €/pc.
L 31 00 331



Caratteristiche tecniche - Technical features

| | |
|---------------------------------|----------------|
| Tipologia-Type | Antenna |
| Banda | TV DVB-T |
| Lunghezza-Length mt. | 0,25 |
| Mancione | Plastic |
| Tipo-Type | Plastic Whip |
| Colore-Colour | Bianco-White |
| Peso-Weight kg. | 0,43 |
| Guadagno-Gain | 24 |
| Montaggio-Mounting | 1"-14 female |
| Cavo/Connettore-Cable/Connector | 5,00 mt. Cable |



Antenna Wi-Fi

Wi-Fi Antenna

Articolo - Item €/pc.
L 31 02 188



Caratteristiche tecniche - Technical features

| | |
|---------------------------------|--------------------|
| Tipologia-Type | Antenna |
| Banda | WiFi |
| Lunghezza-Length mt. | 1,00 |
| Mancione | Chromed brass |
| Tipo-Type | Fiberglass Whip |
| Finitura-Finishing | Polyurethane paint |
| Colore-Colour | Bianco-White |
| Peso-Weight kg. | 0,38 |
| Sezioni-Sections | 1 |
| Montaggio-Mounting | 1"-14 female |
| Cavo/Connettore-Cable/Connector | USB Connector |
| Protezione anifilmine | SI-YES |
| Cortocircuitata a massa | SI-YES |



Kit Antenne e Decoder digitale

Un kit per la ricezione televisiva, dove la tecnologia d'avanguardia del ricevitore digitale terrestre «Diversity Tuner», dalle ridottissime dimensioni, e due antenne TV omnidirezionali VHF-UHF ad alta efficienza, si incontrano per garantire una perfetta ricezione del segnale televisivo in movimento.

Articolo - Item €/kit
L 31 72 001



L'UNICO KIT CHE CONSENTE DI VEDERE LA TV DIGITALE NITIDAMENTE IN MOVIMENTO
THE ONLY KIT THAT ALLOWS TO WATCH THE DIGITAL TV WHEN BOATING



Base snodata

In ABS, con snodo in una sola direzione.

Articulated base

Manufactured in ABS.

| Articolo - Item | €/pc. | A mm. | B mm. | C mm. | D mm. |
|-----------------|-------|-------|-------|-------|-------|
| L 31 54 043 | | 97 | 103 | 25 | 63 |

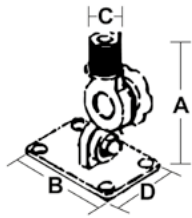

AISI 316

Base fissa Aisi 316

In acciaio inox Aisi 316.

Aisi 316 steady base

Manufactured in Aisi 316.

| Articolo - Item | €/pc. | A mm. | B Ø mm. | C Ø mm. |
|-----------------|-------|-------|---------|---------|
| L 31 09 174 | | 100 | 80 | 25 |

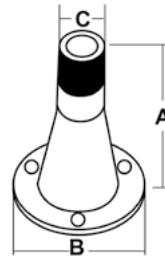

Base doppio snodo

In ABS, con foro per passaggio cavo.

Double joint base

Manufactured in ABS with hole for cable.

| Articolo - Item | €/pc. | A mm. | B mm. | C mm. | D mm. |
|-----------------|-------|-------|-------|-------|-------|
| L 31 54 040 | | 120 | 95 | 25 | 68 |

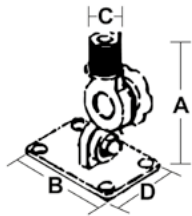

Base doppio snodo con attacco Fast Fit per L3101119

In ABS.

Double joint base with Fast Fit connection for L3101119

Manufactured in ABS.

| Articolo - Item | €/pc. | A mm. | B mm. | C mm. | D mm. |
|-----------------|-------|-------|-------|-------|-------|
| L 31 00 054 | | 120 | 92 | 25 | 65 |

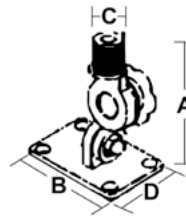

Base senza attacco Fast Fit per L3101119

In acciaio inox Aisi 316, con foro per passaggio cavo.

Base w/out Fast Fit connection for L3101119

Manufactured in Aisi 316 stainless steel. With hole for cable.

| Articolo - Item | €/pc. | A mm. | B mm. | C mm. | D mm. |
|-----------------|-------|-------|-------|-------|-------|
| L 31 00 054 | | 138 | 92 | 25 | 52 |

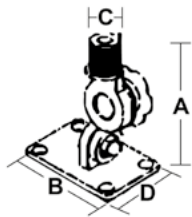

Base doppio snodo

In ottone cromato, con foro per passaggio cavo.

Double joint base

Manufactured in chromed brass with hole for cable.

| Articolo - Item | €/pc. | A mm. | B mm. | C mm. | D mm. |
|-----------------|-------|-------|-------|-------|-------|
| L 31 54 047 | | 120 | 96 | 25 | 58 |

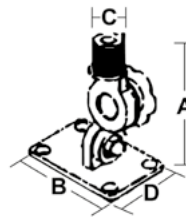

Base snodata

In nylon. Montaggio su tubi Ø 22-25 mm.

Articulated base

Manufactured in nylon. Suitable for pipe Ø 22-25 mm.

| Articolo - Item | €/pc. | A mm. | B mm. | C mm. | D mm. |
|-----------------|-------|-------|-------|-------|-------|
| L 31 54 045 | | - | 44 | 25 | 70 |

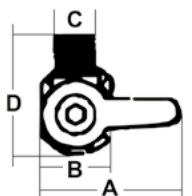

Plotter cartografico NAV-STATION N9

L'interfaccia è di tipo ibrido, ovvero possiamo gestire tutte le funzioni sia con l'ausilio dei tradizionali tasti che tramite touch screen. Inoltre possiamo anche gestire tutte le funzionalità su un dispositivo iOS od Android, ciò grazie all'app Mirror Control in grado di trasferire la stessa schermata presente sul GPS marino e di poterla manovrare tramite il touch screen del dispositivo remoto (smartphone, tablet o smart TV, ma solo un dispositivo alla volta).

Lo schermo è stato appositamente studiato per consentire la visuale da tutte le angolazioni e contrastare il riverbero del sole. Inoltre la tonalità dei colori è regolabile anche per facilitare l'uso notturno senza rimanere abbagliati. Fornito privo di cartografia (da ordinare a parte).

NAV-STATION N9 GPS

The interface is hybrid, i.e. we can manage all the functions both with the help of traditional keys and via touch screen. In addition, we can also manage all the features on an iOS or Android device, thanks to the Mirror Control app that can transfer the same screen on the marine GPS and can operate it via the touch screen of the remote device (smartphone, tablet or smart TV, but only one device at a time).

The screen has been specially designed to allow viewing from all angles and counteract the glare of the sun. In addition, the colour shade can also be adjusted to facilitate night-time use without being dazzled. Supplied without cartography (to be ordered separately).

| | | |
|-----------------|-------|------------------------|
| Articolo - Item | €/pc. | Mod. |
| L 32 09 000 | | Plotter NAV-STATION N9 |



Caratteristiche tecniche - Technical features

| | |
|--|--|
| WiFi integrato | Built-in WiFi |
| Funzione Mirror Control su App | Mirror Control App |
| Sincronia dati con Captain Cloud | Data synchro on Captain Cloud |
| Aggiornamento software automatico da connessione WiFi | Automatic software update via WiFi |
| Interfaccia ibrida (Tasti e touch screen) | Hybrid interface |
| GPS/GLONASS incorporato | Integrated GPS/GLONASS |
| NMEA 2000 e 0183 | NMEA 2000 and 0183 |
| Funzioni ed allarmi per il controllo motore (se interfacciato) | Alarms and functions for engine control (if connected) |
| Tutte le funzionalità AIS (se interfacciato con ricevitore) | AIS (if connected) |
| Cartografia C-Map Max o 4D MAX+ del Mediterraneo | Mediterranean map |
| Slot di memoria MicroSD. | Memory slot MicroSD |
| Impermeabile IPx6 | IPx6 |
| Installabile su staffa od a paratia. | Deck or bracket mounting |
| Display anti-riflesso ed ultra luminoso 1100 nits, 800 x 480 pixel | Display 1100 nits, 800 x 480 pixel |
| Dimensioni 278 x 154 x 97 mm. | Size 278 x 154 x 97 mm. |



SUGGESTED ITEM

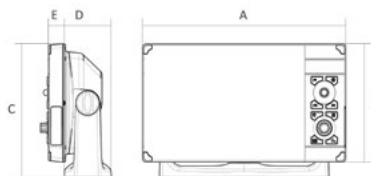
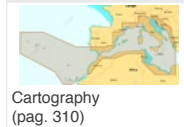

| N9 | |
|----|-------------------|
| A | 278 mm (10,9 in.) |
| B | 154 mm (6,06 in.) |
| C | 174 mm (6,8 in.) |
| D | 64 mm (2,5 in.) |
| E | 32,6 mm (1,2 in.) |

Eco-Plotter NAV-STATION N9-FISH

Nav-Station N9-Fish è uno strumento di navigazione con fishfinder e con funzionalità attentamente studiate per agevolare le batture di pesca.

Il fishfinder è basato su tecnologia CHIRP che è stata attentamente affinata per la migliore identificazione dei pesci e del fondale. Possiamo infatti avere una buona distinzione dei vari dettagli sulle alte profondità (fino a 500 mt. con specifico trasduttore) e avere un discernimento ancora migliore su profondità minori.

Anche le funzionalità del plotter sono eccellenti per l'uso nelle battute di pesca. Possiamo avere letture costanti anche alle più basse velocità ovvero la dove il GPS con il suo margine di errore causa sbalzi fastidiosi. Particolare attenzione è stata anche data nella gestione delle tracce, che formano un vero database completamente personalizzabile. Ad esempio per una determinata traccia è agevole poter cambiare il colore, convertirla in rotta, nascondere o visualizzarla.

Fornito privo di cartografia e trasduttore (da ordinare a parte).

NAV-STATION N9-FISH Fishfinder-Chart plotter

Nav-Station N9-Fish is a navigation instrument with fishfinder and features carefully designed to facilitate fishing trips.

The fishfinder is based on CHIRP technology that has been carefully refined for the best identification of fish and seabed. We can in fact have a good distinction of the various details on the high depths (up to 500 mt. with specific transducer) and have an even better discernment on shallower depths.

The plotter's functionality is also excellent for use on fishing trips. We can have constant readings even at the lowest speeds, where the GPS with its margin of error causes annoying overhangs. Particular attention has also been given to the management of the tracks, which form a real database fully customizable. For example, for a certain track it is easy to change the color, convert it to a route, hide it or display it.

Supplied without cartography and stern transducer (to be ordered separately).

| | | |
|-----------------|-------|---------------------------------------|
| Articolo - Item | €/pc. | Mod. |
| L 46 09 000 | | Eco-Plotter-Fishfinder-Chart Plotter |
| L 46 09 311 | | Trasduttore di poppa-Stern transducer |



Caratteristiche tecniche - Technical features

| | |
|---|--|
| WiFi integrato | Built-in WiFi |
| Funzione Mirror Control su App | Mirror Control App |
| Sincronia dati con Captain Cloud | Data synchro on Captain Cloud |
| Aggiornamento software automatico da connessione WiFi. | Automatic software update via WiFi |
| Interfaccia ibrida (Tasti e touch screen). | Hybrid interface |
| GPS/GLONASS incorporato. | Integrated GPS/GLONASS |
| NMEA 2000 e 0183. | NMEA 2000 and 0183 |
| Funzioni ed allarmi per il controllo motore (se interfacciato). | Alarms and functions for engine control (if connected) |
| Tutte le funzionalità AIS (se interfacciato con ricevitore). | AIS (if connected) |
| Cartografia C-Map Max o 4D MAX+ del Mediterraneo | Mediterranean map |
| Slot di memoria MicroSD. | Memory slot MicroSD |
| Impermeabile IPx6 | IPx6 |
| Installabile su staffa od a paratia. | Deck or bracket mounting |
| Display anti-riflesso ed ultra luminoso 1100 nits, 800 x 480 pixel. | Display 1100 nits, 800 x 480 pixel |
| Dimensioni 278 x 154 x 97 mm. | Size 278 x 154 x 97 mm. |
| Trasduttore di poppa | Transducer |



SUGGESTED ITEM

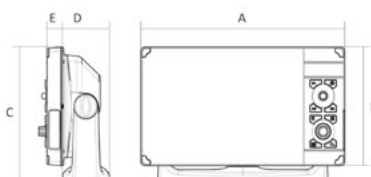
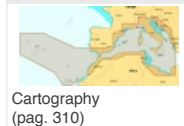

| N9 | |
|----|-------------------|
| A | 278 mm (10,9 in.) |
| B | 154 mm (6,06 in.) |
| C | 174 mm (6,8 in.) |
| D | 64 mm (2,5 in.) |
| E | 32,6 mm (1,2 in.) |



Cartografie per NAV-STATION N9 e per eco plotter NAV STATION N9 FISH.

Cartografie ideali per modelli NAV STATION N9 e per eco plotter NAV STATION N9 FISH.

NAV-STATION Maps

Maps for models NAV STATION N9 and eco plotter NAV STATION N9 FISH.

| | | |
|-----------------|-------|--|
| Articolo - Item | €/pc. | Cartografia-Cartography. |
| L 46 09 001 | | Mediterraneo Occidentale-Western Mediterranean |
| L 46 09 002 | | Mediterraneo Orientale-Eastern Mediterranean |



Scandaglio a mano

Sagola fabbricata in treccia di nylon provvista di segnale per ogni metro e ogni 10 metri. Sonda in piombo.

Hand depth sounder

Nylon line with a mark every meter and every 10 meters. Lead probe.

| Articolo - Item | €/pc. | Treccia-Rope Ø mm. | kg. |
|-----------------|-------|--------------------|-------|
| L 46 04 030 | | 4 | 0,600 |



POMPA IDRAULICA TRIM | TRIM HYDRAULIC PUMP

Pompa idraulica ideale per Trim compatibile con motori Mercruiser

Provvista di motore e serbatoio.

Trim hydraulic pump for Mercruiser engines

Supplied with motor and tank.

| Articolo - Item | €/pc. | mm. | Volts | kg. |
|-----------------|-------|-------------|-------|-------|
| L 32 10 501 | | 173x151x274 | 12 | 4,440 |



STABILIZZATORI | STABILIZERS

Stabilizzatori «Hydrofoil Fin»

Realizzati in poliammide nero, universali per ogni marca di motore fuoribordo. Si applicano in 5 minuti alla piastra di anticavitazione e presentano i seguenti vantaggi:

1. planate in metà tempo dell'usuale e con minore spreco di potenza e di carburante;
2. eliminano i fenomeni di cavitazione;
3. hanno una maggiore stabilità di navigazione e un assetto più sensibile alla regolazione del Trim

Stabilizers «Hydrofoil Fin»

Made of black polyamide, universal size for outboard engine power.

1. Fitting onto the plate.
2. No cavitation.
3. Greater navigation stability and an attitude that is more sensible to adjustments on the Trim. Fuel saving.

| Articolo - Item | €/kit | A mm. | B mm. | Per motori-For engines | kg. |
|-----------------|-------|-------|-------|------------------------|-------|
| L 32 88 062 | | 194 | 174 | 4 ≈50 HP | 0,870 |
| L 32 88 061 | | 264 | 216 | > 50 HP | 0,600 |

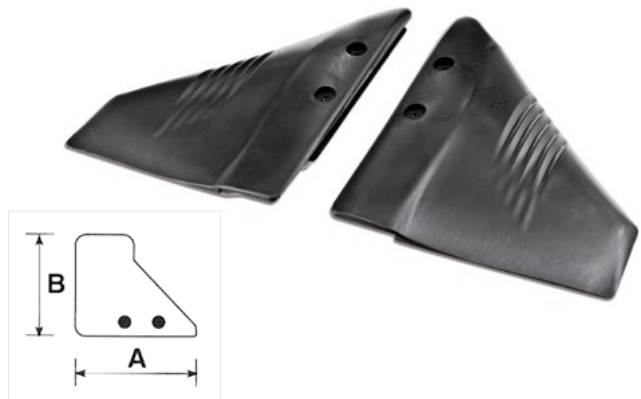

Stabilizzatori «Sport»

1. planate in metà tempo dell'usuale e con minore spreco di potenza e di carburante;
2. eliminano i fenomeni di cavitazione;
3. hanno una maggiore stabilità di navigazione e un assetto più sensibile alla regolazione del Trim

Stabilizers «Sport»

1. Fitting onto the plate.
2. No cavitation.
3. Greater navigation stability and an attitude that is more sensible to adjustments on the Trim. Fuel saving.

| Articolo - Item | €/kit | Mod. | Per motori-For engines | kg. |
|-----------------|-------|--|------------------------|-------|
| L 32 08 200 | | Sport 200 | 8 HP ≈ 40 HP | 1,250 |
| L 32 00 300 | | Clips per montaggio Sport 200 senza forare clips for mounting Sport 200 without drilling | | 1,250 |



**MONTAGGIO SENZA VITI ACQUISTANDO LE CLIPS
INSTALLATION WITHOUT SCREWS BUYING THE CLIPS**

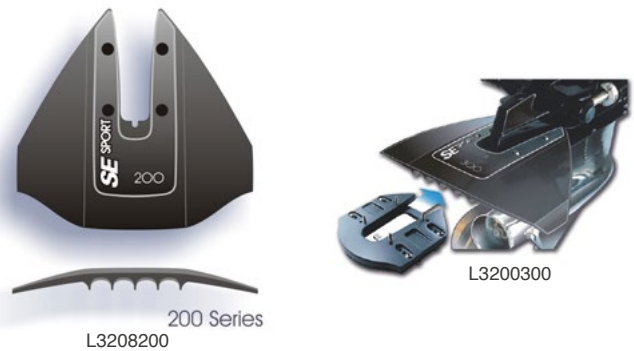

Piastra per stabilizzatori in alluminio anodizzato

Stabilizer plate in anodised aluminium

| Articolo - Item | €/kit | HP | Per motori-For engines |
|-----------------|-------|-----------|-------------------------------------|
| L 32 35 500 | | 25-30 HP | Yamaha, Honda, Suzuki, Mercury, ECT |
| L 32 40 501 | | 40-140 HP | Yamaha, Honda, Suzuki, Mercury, ECT |
| L 32 70 502 | | 70-250 HP | Yamaha, Honda, Suzuki, Mercury, ECT |

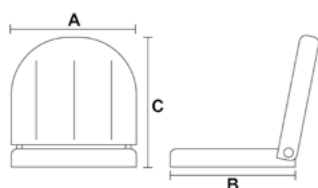

POLTRONCINE DI GUIDA | PILOT SEATS

**Poltroncina «Commodore»**

In polietilene bianco.
Completa di 8 inserti filettati in ottone per fissaggio colonne e slitte.

| Articolo - Item | €/pc. | A cm. | B cm. | C cm. | Set cuscini ricambio Spare cushions set |
|-----------------|-------|-------|-------|-------|---|
| O 14 05 000 | | 50 | 51 | 52 | O1405100 |



made by

**COMPLETO DI VITI DI FISSAGGIO
WITH FASTENING SCREWS****Pilot seat «Commodore»**

Manufactured in white polyethylene.
Complete with brass fittings for fastening.

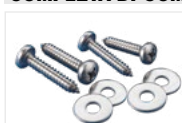
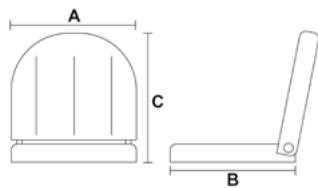
COMPLETO DI-COMLETE WITHArt. O1421354
(pag. 320)**SUGGESTED ITEM**Art. O1405100
(pag. 318)BASI-BASE
(pag. 319)**Poltroncina «Sailor»**

In polietilene rotazionale bianco.
Completa di 8 inserti filettati in ottone per fissaggio colonne e slitte.

| Articolo - Item | €/pc. | A cm. | B cm. | C cm. | Set cuscini ricambio Spare cushions set |
|-----------------|-------|-------|-------|-------|---|
| O 14 38 000 | | 51 | 40 | 42 | O1438100 |



made by

**COMPLETO DI VITI DI FISSAGGIO
WITH FASTENING SCREWS****Pilot seat «Sailor»**

Manufactured in white polyethylene.
Complete with brass fittings for fastening.

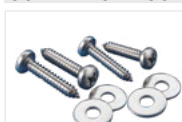
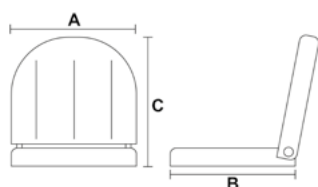
COMPLETO DI-COMLETE WITHArt. O1421354
(pag. 320)**SUGGESTED ITEM**Art. O1438100
(pag. 318)BASI-BASE
(pag. 319)**Poltroncina «Fisherman»**

In polietilene rotazionale bianco.
Completa di 8 inserti filettati in ottone per fissaggio colonne e slitte.

| Articolo - Item | €/pc. | A cm. | B cm. | C cm. |
|-----------------|-------|-------|-------|-------|
| O 14 50 000 | | 51 | 48 | 41 |

**COMPLETO DI CUSCINI
WITH CUSHIONS****Pilot seat «Fisherman»**

Manufactured in white polyethylene.
Complete with brass fittings for fastening.

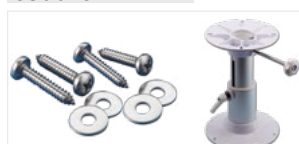
SUGGESTED ITEMArt. O1421354
(pag. 320)BASI-BASE
(pag. 319)

Poltroncina «Captain»

In polietilene rotazionale bianco.
Completa di 8 inserti filettati in ottone per fissaggio colonne e slitte.

Pilot seat «Captain»

Manufactured in white polyethylene.
Complete with brass fittings for fastening.

| Articolo - Item | €/pc. | Viti Screws | A cm. | B cm. | C cm. | Cuscini-Cushions Optional |
|-----------------|-------|-------------------|-------|-------|-------|---------------------------|
| O 14 20 054 | | Optional O1421354 | 51 | 40 | 42 | O1411100 |
| O 14 11 000 | | Complete O1421354 | 51 | 40 | 42 | O1411100 |



SUGGESTED ITEM

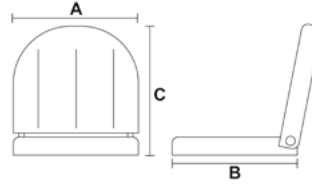

Poltroncina «Captain Plus»

In polietilene rotazionale bianco.
Completa di 8 inserti filettati in ottone per fissaggio colonne e slitte.

Pilot seat «Captain Plus»

Manufactured in white polyethylene.
Complete with brass fittings for fastening.

| Articolo - Item | €/pc. | A cm. | B cm. | C cm. | Cuscini-Cushions Optional |
|-----------------|-------|-------|-------|-------|---------------------------|
| O 14 21 000 | | 51 | 40 | 42 | O1421100 |



COMPLETO DI-COMLETE WITH

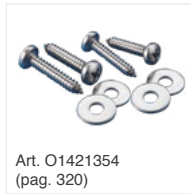

SUGGESTED ITEM

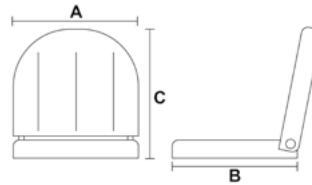

Poltroncina «Admiral»

In polietilene rotazionale bianco.
Completa di 8 inserti filettati in ottone per fissaggio colonne e slitte.

Pilot seat «Admiral»

Manufactured in white polyethylene.
Complete with brass fittings for fastening.

| Articolo - Item | €/pc. | Viti Screws | A cm. | B cm. | C cm. | Cuscini-Cushions Optional |
|-----------------|-------|-------------------|-------|-------|-------|---------------------------|
| O 14 11 002 | | Complete O1421354 | 40 | 40 | 40 | O1411102 |



SUGGESTED ITEM

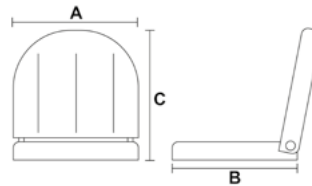

Poltroncina «Admiral Plus»

In polietilene rotazionale bianco.
Completa di 8 inserti filettati in ottone per fissaggio colonne e slitte.

Pilot seat «Admiral Plus»

Manufactured in white polyethylene.
Complete with brass fittings for fastening.

| Articolo - Item | €/pc. | A cm. | B cm. | C cm. | Cuscini-Cushions Optional |
|-----------------|-------|-------|-------|-------|---------------------------|
| O 14 21 002 | | 40 | 40 | 40 | O1421102 |



COMPLETO DI-COMLETE WITH

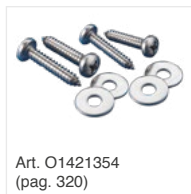

SUGGESTED ITEM

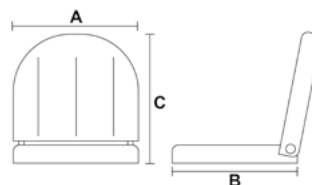



Poltroncina «Egeo»

In Sky con anima in legno.
Colore beige.

Pilot seat «Egeo»

Manufactured in Sky and wooden core.
Beige colour.

| Articolo - Item | €/pc. | A cm. | B cm. | C cm. | Completa di viti With screws |
|-----------------|-------|-------|-------|-------|------------------------------|
| O 14 31 430 | | 48 | 48 | 31 | O1421354 |

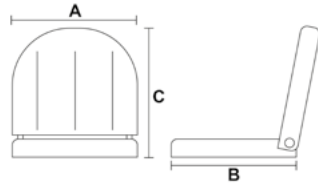

COMPLETA DI-COMLETE WITH

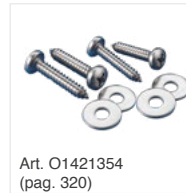

SUGGESTED ITEM



Poltroncina «Baltic»

In similpelle colore bianco.
Applicabile ai supporti TREM.
Completa di cerniere.

Pilot seat «Baltic»

Manufactured in leatherette white colour.
Complete with hinges.

| Articolo - Item | €/pc. | A cm. | B cm. | C cm. | Completa di viti With screws |
|-----------------|-------|-------|-------|-------|------------------------------|
| O 14 74 481 | | 43 | 38 | 56 | O1421354 |

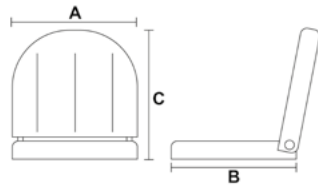

COMPLETA DI-COMLETE WITH

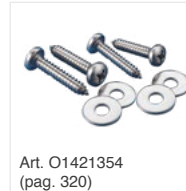

SUGGESTED ITEM



**Poltroncina «Pilot»
con schienale ripiegabile**

In similpelle colore bianco.
Applicabile ai supporti TREM.
Completa di cerniere.

**Pilot seat «Baltic»
with folding back**

Manufactured in leatherette white colour.
Complete with hinges.

| Articolo - Item | €/pc. | A cm. | B cm. | C cm. | Completa di viti With screws |
|-----------------|-------|-------|-------|-------|------------------------------|
| O 14 12 074 | | 40 | 38 | 48 | O1421354 |

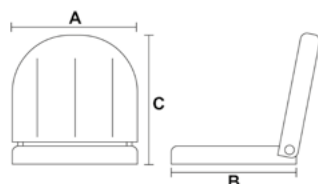

COMPLETA DI-COMLETE WITH

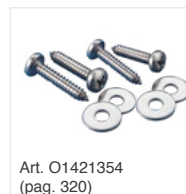

SUGGESTED ITEM



**Poltroncina a ribalta
«Yachtsman»**

In polietilene rotazionale bianco.
Modello che consente di ripiegare il sedile per
ottenere più spazio e guidare in piedi.

**Folding pilot seat
«Yachtsman»**

This model allows to drive standing.
More space available.

| Articolo - Item | €/pc. | A cm. | B cm. | C cm. | Slitta-Sliding steering Optional | Piastra-Plate Optional |
|-----------------|-------|----------|----------|----------|-------------------------------------|---------------------------|
| O 14 07 000 | | 45 | 40 | 42 | O1410205 | O1418210 |

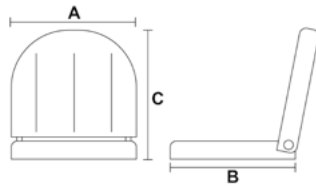

COMPLETA DI-COMLETE WITH

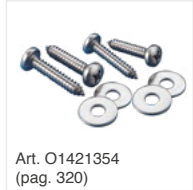

SUGGESTED ITEM



**Poltroncina a ribalta imbottita
«Yachtsman»**

In polietilene rotazionale bianco.
Modello che consente di ripiegare il sedile per
ottenere più spazio e guidare in piedi.

**Folding padded pilot seat
«Yachtsman»**

Manufactured in white polyethylene.
This model allows to drive standing.

| Articolo - Item | €/pc. | A cm. | B cm. | C cm. | Slitta-Sliding steering Optional | Piastra-Plate Optional |
|-----------------|-------|----------|----------|----------|-------------------------------------|---------------------------|
| O 14 03 000 | | 45 | 40 | 42 | O1410205 | O1418210 |

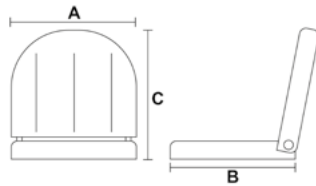

COMPLETA DI-COMLETE WITH

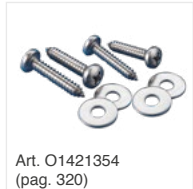

SUGGESTED ITEM



**Poltroncina a ribalta senza
rivestimento «Deluxe»**

Anima in polietilene antiurto.
Priva di rivestimento.

**Folding pilot seat without
upholstery «Deluxe»**

Shockproof polyethylene core.
Without upholstery.

| Articolo - Item | €/pc. | A cm. | B cm. | C cm. | Tavoletta per montaggio su basi |
|-----------------|-------|----------|----------|----------|---------------------------------|
| O 14 00 181 | | 55 | 42 | 48 | OT1400181 |

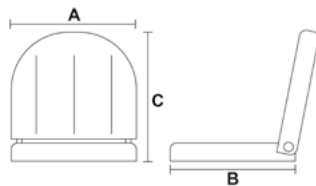

COMPLETA DI-COMLETE WITH

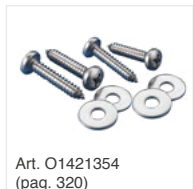

SUGGESTED ITEM

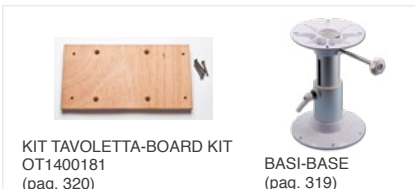

POLTRONCINE DI GUIDA COMPLETE | COMPLETE PILOT SEATS

**Poltroncina di guida
«Captain»**

Completa di cuscino e base telescopica.

**Pilot seat
«Captain»**

Complete with adjustable base and cushion.

| Articolo - Item | €/pc. | H mm. |
|-----------------|-------|-----------|
| O 14 11 040 | | 400 ÷ 600 |

**COMPLETE WITH**

BASE
O1426040
(pag. 319)



POLTRONCINA-SEAT
O1411000
(pag. 313)



CUSCINO-CUSHION
O1411100
(pag. 318)

**Poltroncina di guida
«Sailor»**

Completa di cuscino e base telescopica.

**Pilot seat
«Sailor»**

Complete with adjustable base and cushion.

| Articolo - Item | €/pc. | H mm. |
|-----------------|-------|-----------|
| O 14 38 040 | | 400 ÷ 600 |

**COMPLETE WITH**

BASE
O1426040
(pag. 319)



POLTRONCINA-SEAT
O1438000
(pag. 312)



CUSCINO-CUSHION
O1438100
(pag. 318)

**Poltroncina di guida
«Admiral»**

Completa di cuscino e base telescopica.

**Pilot seat
«Admiral»**

Complete with adjustable base and cushion.

| Articolo - Item | €/pc. | H mm. |
|-----------------|-------|-----------|
| O 14 11 042 | | 400 ÷ 600 |

**COMPLETE WITH**

BASE
O1426040
(pag. 319)



POLTRONCINA-SEAT
O1411002
(pag. 313)



CUSCINO-CUSHION
O1411102
(pag. 318)

**Poltroncina di guida
«Admiral Plus»**

Completa di cuscino e base telescopica.

**Pilot seat
«Admiral Plus»**

Complete with adjustable base and cushion.

| Articolo - Item | €/pc. | H mm. |
|-----------------|-------|-----------|
| O 14 21 042 | | 400 ÷ 600 |

**COMPLETE WITH**

BASE
O1426040
(pag. 319)



POLTRONCINA-SEAT
O1421002
(pag. 313)



CUSCINO-CUSHION
O1421102
(pag. 318)

Cassero di guida con maniglione

In vetroresina.
Predisposto per ricevere l'applicazione della timoneria rotativa.
Di facile applicazione al pagliolo.
Tientibene in acciaio inox ed antina completa di serratura.
Dotato di nicchia porta estintore.

Quarterdeck in fibreglass with wood finishing

In fibreglass.
With stainless steel handrail, little door with lock and extinguisher compartment.
Suitable for rotary steering system.
Easy application on boats dunnage.

| Articolo - Item | €/pc. | ↕ mm. | H mm. | 📦 kg. |
|-----------------|-------|---------|---------------------|-------|
| L 53 37 093 | | 360x370 | 700+230 (corrimano) | 7,700 |



COMPLETO DI-COMPLETE WITH

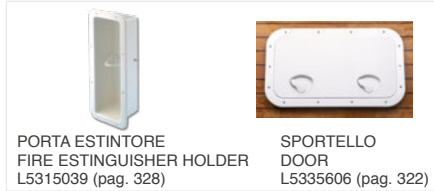

PORTA ESTINTORE
FIRE EXTINGUISHER HOLDER
L5315039 (pag. 328)



SPORTELLINO
DOOR
L5335606 (pag. 322)

SUGGESTED ITEM



ESTINTORE
FIRE EXTINGUISHER
E0013020 (pag. 112)

Gavone biposto «Florida»

In vetroresina.
Completo di cuscino in similpelle bianco.
Indicato a corredo del cassero come seduta anteriore.

Two-seater peak «Florida»

In fibreglass.
With white cushion in leather imitation.

| Articolo - Item | €/pc. | ↕ mm. | 📦 kg. |
|-----------------|-------|--------------|-------|
| O 24 00 073 | | 700x400x380H | 6,000 |



COMPLETO DI-COMPLETE WITH



O1404080
(pag. 317)



Cuscino biposto «Florida»

Interno in gomma piuma.
Rivestito in similpelle bianco.

Two-seater cushion

In fibreglass.
With white cushion in leather imitation.

| Articolo - Item | €/pc. | ↕ mm. | 📦 kg. |
|-----------------|-------|---------|-------|
| O 14 04 080 | | 700x400 | |



VISIT OUR B2B AREA

- CREATE A CUSTOMER ACCOUNT
- CHECK AVAILABILITY & QUANTITY OF ITEMS
- CHECK YOUR COMMERCIAL CONDITION
- PLACE YOUR ORDER
- TRACK YOUR ORDER STATUS
- TRACK YOUR PAYMENT PROCESS



WWW.TREM.NET



ACCESSORI PER POLTRONCINE | ACCESSORIES FOR PILOTE SEATS

Cuscino e schienale per poltroncina «Captain» **Cushion and backrest for pilote seat «Captain»**

Articolo - Item €/pc.
O 14 11 100



Cuscino e schienale per poltroncina «Captain Plus» **Cushion and backrest for pilote seat «Captain Plus»**

Articolo - Item €/pc.
O 14 21 100



Cuscino e schienale per poltroncina «Admiral» **Cushion and backrest for pilote seat «Admiral»**

Articolo - Item €/pc.
O 14 11 102



Cuscino e schienale per poltroncina «Admiral Plus» **Cushion and backrest for pilote seat «Admiral Plus»**

Articolo - Item €/pc.
O 14 21 102



Cuscino e schienale per poltroncina «Commodore» **Cushion and backrest for pilote seat «Commodore»**

Articolo - Item €/pc.
O 14 05 100

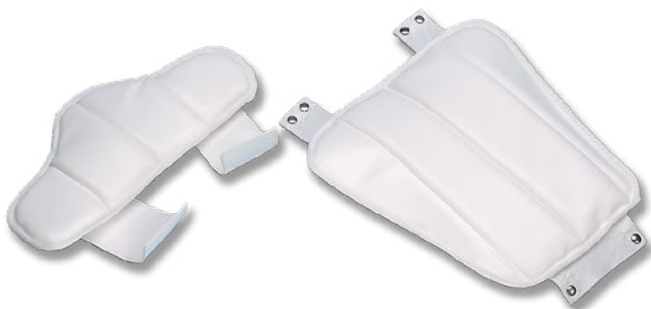

Cuscino e schienale per poltroncina «Sailor» **Cushion and backrest for pilote seat «Sailor»**

Articolo - Item €/pc.
O 14 38 100



Supporto sedili girevoli in alluminio anodizzato

Anodised aluminium pilote seat bases

Completo di bocche in nylon antifrizione. Finitura molto accurata. Tubi anodizzati.

Complete with nylon bushings.

| Articolo - Item | €/pc. | H mm. | Mod. | Base superiore Upper base | Base fissaggio Fixing base | Colonna-Column Ø mm. | Base Ø mm. | kg. |
|-----------------|-------|---------|--------------|---------------------------------|---------------------------------|-------------------------|---------------|-----|
| O 14 26 024 | | 260 | Fisso-Steady | Alu | Sabbiata-Sanded | 90 | 240 | |
| O 14 26 056 | | 500 | Fisso-Steady | Alu bianco-white | Alu bianco-white | 90 | 240 | |
| O 14 26 025 | | 250-320 | Telescopico | Alu bianco-white | Alu bianco-white | 90-80 | 240 | |
| O 14 29 040 | | 400-600 | Telescopico | Nylon rinforzato-Reinforced alu | Nylon rinforzato-Reinforced alu | 90-80 | 240 | |
| O 14 26 040 | | 400-600 | Telescopico | Alu bianco-white | Alu bianco-white | 90-80 | 240 | |
| O 14 57 040 | | 400-600 | Telescopico | Alu bianco-white | Alu bianco-white | 100-90 | 300 | |
| O 14 27 040 | | 400-600 | Telescopico | Alu | Sabbiata-Sanded | 90-80 | 240 | |



É possibile chiedere altezze personalizzate per min. 20 pz.
It's possible to customise the height of supports for min. 20 pcs.



O1426024

O1426056

O1426025

O1429040

O1426040

O1457040

O1427040

Supporto sedile con movimento telescopico a gas

Gas telescopic pilot seat base

In alluminio anodizzato, provvisto di leva che aziona e disinserisce l'attuatore.

Manufactured in anodised aluminium. With handles.

| Articolo - Item | €/pc. | H mm. | Base superiore Upper base | Base fissaggio Fixing base | Colonna-Column Ø mm. | Base Ø mm. |
|-----------------|-------|---------|------------------------------|-------------------------------|-------------------------|---------------|
| O 15 26 040 | | 400-600 | Alu bianco-white | Alu bianco-white | 90-80 | 240 |



Supporto sedile con testa girevole

Swivelling pilot seat base

Base colonna in alluminio anodizzato. Supporto sedile girevole in alluminio verniciato grigio.

Manufactured in anodised aluminium. Swivelling head manufactured in grey painted aluminium.

| Articolo - Item | €/pc. | H mm. | Mod. | Colonna-Column Ø mm. | Base Ø mm. |
|-----------------|-------|---------|-------------|-------------------------|---------------|
| O 15 43 063 | | 430-630 | Telescopico | 73-60 | 228 |



SUGGESTED ITEM



SLITTA-SLIDE
O1438310
(pag. 321)



Supporto sedile con slitta girevole

Swivelling pilot seat sliding steering

Realizzata in alluminio lucidato a specchio e anodizzato, con basi di grande diametro e tubi a forte spessore. Finitura accuratissima. Adattabili a tutte le scocche sedile.

Manufactured in anodised and mirror polished aluminium, with large diameter base and large thickness pipes.

| Articolo - Item | €/pc. | H mm. | Mod. | Colonna-Column Ø mm. | Base Ø mm. | Base |
|-----------------|-------|---------|-------------|-------------------------|---------------|-----------------|
| O 15 30 040 | | 300-400 | Telescopico | 88-73 | 305 | Lucida-Polished |
| O 15 35 047 | | 350-480 | Telescopico | 88-73 | 305 | Lucida-Polished |



Coprisedile in tessuto

Fabbricato in tessuto poliestere 300D con rivestimento impermeabile in poliuretano.

| Articolo - Item | €/pc. | A cm. | B cm. | C cm. | Colore Colour |
|-----------------|-------|-------|-------|-------|---------------|
| O 14 12 000 | | 45 | 55 | 53 | Grigio-Grey |



Pilot seat cover

Manufactured in polyester fabrics 300D with waterproof polyurethane covering.

**PER POLTRONCINE
FOR PILOT SEATS**

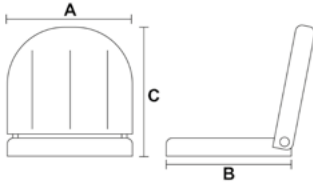

Appoggiapiedi per poltroncine

Fabbricato in alluminio e legno. Adatto per tubo Ø 90 mm.

| Articolo - Item | €/pc. |
|-----------------|-------|
| D 17 90 000 | |



Footrest for chairs

Manufactured in aluminium and wood. Suitable for pipe Ø 90 mm.

Piastra adattatrice universale

Può essere utilizzata anche come rinforzo. Fabbricata in alluminio anodizzato 4 mm.

| Articolo - Item | €/pc. | mm. | kg. |
|-----------------|-------|---------|-------|
| O 14 22 325 | | 320x220 | 0,700 |



Universal adapting plate

Manufactured in anodised aluminium 4 mm.

Piastra di rinforzo per poltroncina «Yachtsman»

Può essere utilizzata anche come rinforzo. Fabbricata in alluminio anodizzato 4 mm.

| Articolo - Item | €/pc. | mm. | kg. |
|-----------------|-------|---------|-------|
| O 14 18 210 | | 240x220 | 0,700 |



Reinforcement plate for pilot seat «Yachtsman»

Manufactured in anodised aluminium 4 mm.

Tavoletta adattatrice e rinforzo poltroncine «Deluxe»

Realizzata in Iroko.

| Articolo - Item | €/pc. |
|-----------------|-------|
| OT 14 00 181 | |

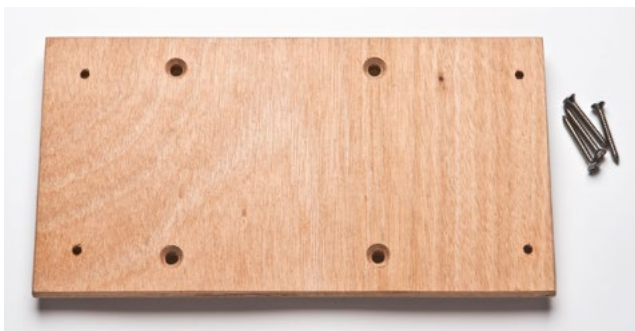

Universal adapting plate for pilot seat «Deluxe»

Manufactured in Iroko.

Kit viteria fissaggio poltroncine

Composto da 4 viti Aisi 316 e 4 rondelle.

| Articolo - Item | €/Kit |
|-----------------|-------|
| O 14 21 354 | |



Fastening screws kit for pilot seats

Kit complete with 4 Aisi 316 screws and 4 washers.



Base girevole frizionata

Fabbricata in acciaio verniciato.

Swivelling base

Manufactured in painted steel.

| Articolo - Item | €/pc. | A mm. | B mm. | kg. |
|-----------------|-------|-------|-------|-------|
| D 17 20 160 | | 175 | 175 | 1,250 |

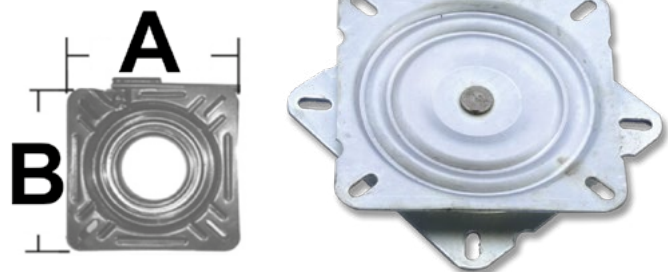

Base girevole

Fabbricata in acciaio inox Aisi 316.

Swivelling base

Manufactured in Aisi 316 stainless steel.

| Articolo - Item | €/pc. | A mm. | B mm. | kg. |
|-----------------|-------|-------|-------|-------|
| D 17 12 563 | | 175 | 175 | 1,000 |

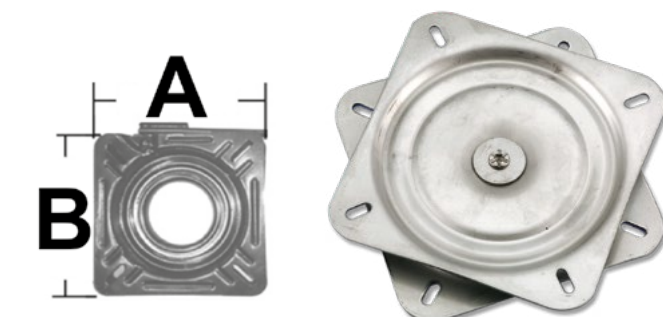

Slitta scorrevole universale

Fabbricata in alluminio anodizzato. Completa di accessori per il montaggio.

Universal sliding steering

Manufactured in light anodized alloy. With fitting accessories.

| Articolo - Item | €/pc. | mm. | kg. |
|-----------------|-------|---------|-------|
| O 14 10 911 | | 200x315 | 1,600 |

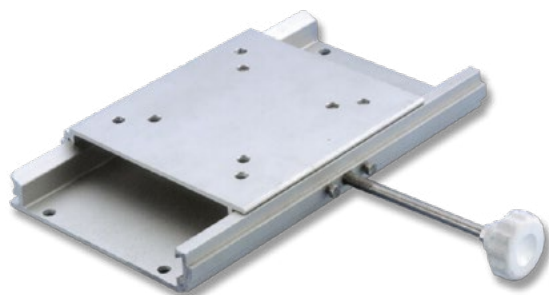

Slitta scorrevole per poltroncina «Yachtsman»

Fabbricata in alluminio.

Sliding steering for pilot seat «Yachtsman»

Manufactured in aluminium.

| Articolo - Item | €/pc. | mm. | kg. |
|-----------------|-------|---------|-------|
| O 14 10 205 | | 200x200 | 1,000 |



Slitta per poltroncina

Fabbricata in alluminio anodizzato. Completa di accessori per il montaggio.

Sliding steering for pilot seat

Manufactured in light anodized alloy. With fitting accessories.

| Articolo - Item | €/pc. | mm. | kg. |
|-----------------|-------|---------|-------|
| O 14 38 310 | | 340x180 | 2,050 |



SUGGESTED ITEM

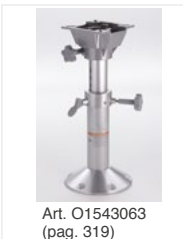
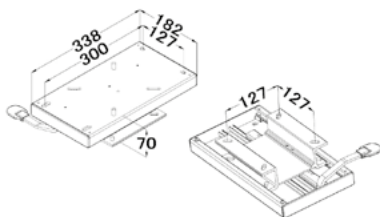

Slitta scorrevole universale

Fabbricata in alluminio. Completa di accessori per il montaggio.

Sliding steering for pilot seat

Manufactured in aluminium. With fitting accessories.

| Articolo - Item | €/pc. | mm. | Corsa Stroke mm. | kg. |
|-----------------|-------|---------|------------------|-------|
| O 14 22 040 | | 200x315 | 130 | 1,700 |

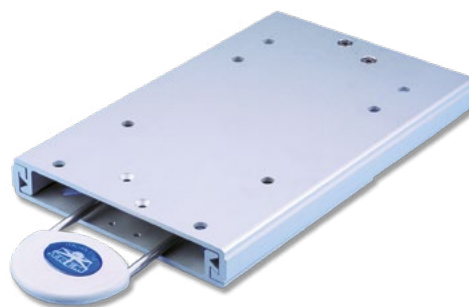

PORTELLI D'ISPEZIONE | INSPECTION HATCHES

Portello d'ispezione

Fabbricato in AAS.
Resistente agli urti e agli spruzzi.

| Articolo - Item | Articolo - Item | Articolo - Item | Articolo - Item | €/pc. |
|-----------------|-----------------|-----------------|-----------------|-------|
| White 9003 | VTR9010 | Nero-Black | Grey 7001 | €/pc. |
| L 53 35 606 | L 53 33 606 | L 53 80 606 | L 53 79 606 | |

Inspection hatch

Manufactured in AAS.
Shock and splash proof.

| A mm. | B mm. | C mm. | D mm. | E mm. | F mm. | Kit serratura Door lock Optional | Kit tasca p/documenti Docs case kit |
|-------|-------|-------|-------|-------|-------|----------------------------------|-------------------------------------|
| 355 | 600 | 250 | 500 | 275 | 525 | M3512034 | D1075355 |

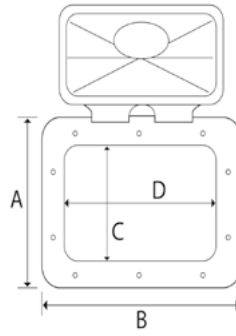

COMPLETE WITH



SUGGESTED ITEMS

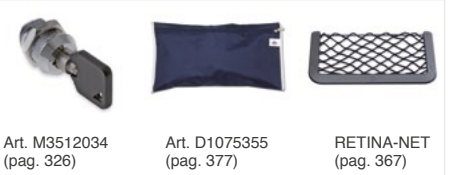

Portello d'ispezione

Fabbricato in AAS.
Resistente agli urti e agli spruzzi.

| Articolo - Item | Articolo - Item | Articolo - Item | Articolo - Item | €/pc. |
|-----------------|-----------------|-----------------|-----------------|-------|
| White 9003 | VTR9010 | Nero-Black | Grey 7001 | €/pc. |
| L 53 37 370 | L 53 33 370 | L 53 80 370 | L 53 79 370 | |

Inspection hatch

Manufactured in AAS.
Shock and splash proof.

| A mm. | B mm. | C mm. | D mm. | E mm. | F mm. | Kit serratura Door lock Optional |
|-------|-------|-------|-------|-------|-------|----------------------------------|
| 375 | 370 | 290 | 285 | 315 | 308 | M3512034 |

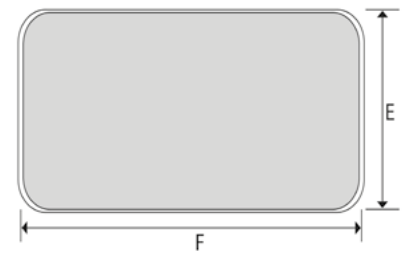
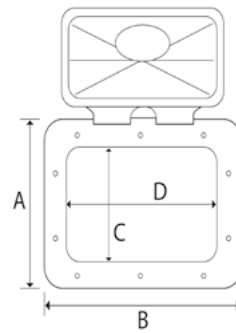

COMPLETE WITH



SUGGESTED ITEMS



Portello d'ispezione

Fabbricato in AAS. Resistente agli urti e agli spruzzi.

| Articolo - Item | Articolo - Item | Articolo - Item | Articolo - Item | €/pc. |
|-----------------|-----------------|-----------------|-----------------|-------|
| White 9003 | VTR9010 | Nero-Black | Grey 7001 | |
| L 53 46 515 | L 53 33 515 | L 53 80 515 | L 53 79 515 | |

Inspection hatch

Manufactured in AAS. Shock and splash proof.

| A mm. | B mm. | C mm. | D mm. | E mm. | F mm. | Kit serratura Door lock Opt. | Kit tasca p/docum. Docs case kit |
|-------|-------|-------|-------|-------|-------|------------------------------|----------------------------------|
| 463 | 517 | 362 | 416 | 386 | 442 | M3512034 | D1075355 |

made by **UV-RESISTANT**

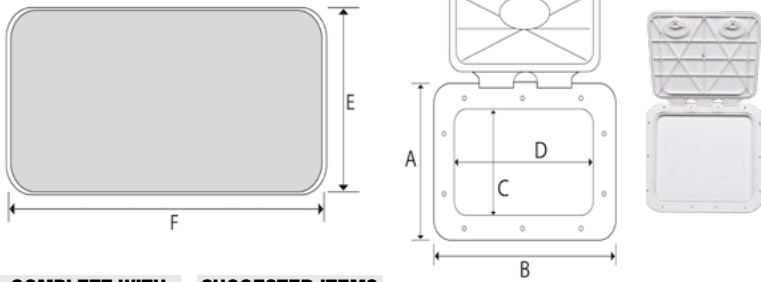

COMPLETE WITH

SUGGESTED ITEMS



Portello d'ispezione

Fabbricato in AAS. Resistente agli urti e agli spruzzi.

| Articolo - Item | Articolo - Item | Articolo - Item | Articolo - Item | €/pc. |
|-----------------|-----------------|-----------------|-----------------|-------|
| White 9003 | VTR9010 | Nero-Black | Grey 7001 | |
| L 53 27 375 | L 53 33 375 | L 53 80 375 | L 53 79 375 | |

Inspection hatch

Manufactured in AAS. Shock and splash proof.

| A mm. | B mm. | C mm. | D mm. | E mm. | F mm. | Kit serratura Door lock Opt. |
|-------|-------|-------|-------|-------|-------|------------------------------|
| 275 | 375 | 180 | 280 | 200 | 300 | M3512034 |

made by **UV-RESISTANT**

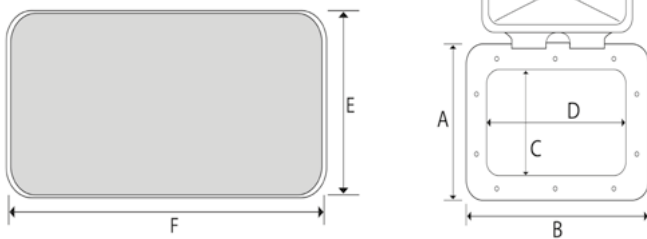

COMPLETE WITH

SUGGESTED ITEMS



Portello d'ispezione con contenitore

Fabbricato in AAS. Resistente agli urti e agli spruzzi. Contenitore in ABS.

| Articolo - Item | Articolo - Item | Articolo - Item | Articolo - Item | €/pc. |
|-----------------|-----------------|-----------------|-----------------|-------|
| White 9003 | VTR9010 | Nero-Black | Grey 7001 | |
| L 53 16 375 | L 53 16 033 | L 53 16 080 | L 53 16 079 | |

Inspection hatch with box

Manufactured in AAS. Shock and splash proof. ABS box.

| A mm. | B mm. | C mm. | D mm. | E mm. | F mm. | G mm. | H mm. | I mm. | Kit serratura Door lock Opt. |
|-------|-------|-------|-------|-------|-------|-------|-------|-------|------------------------------|
| 275 | 375 | 180 | 280 | 270 | 170 | 160 | 210 | 305 | M3512034 |

made by **UV-RESISTANT**

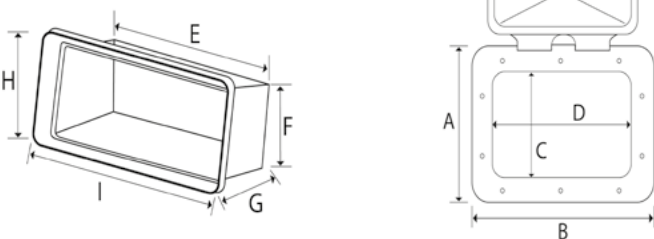

COMPLETE WITH

SUGGESTED ITEMS



PORTELLI D'ISPEZIONE | INSPECTION HATCHES

Portello calpestabile in AAS

Completo di fori per retine VHF. Alta resistenza ai raggi UV.

Waterproof AAS walkable inspection hatch

Complete with internal holes for object-holder nets. Highly UV-resistant.

| Articolo - Item | Articolo - Item | Articolo - Item | Articolo - Item | € /pc. | A mm. | B mm. | C mm. | D mm. | E mm. | F mm. | Kit serratura Door lock Optional |
|-----------------|-----------------|-----------------|-----------------|--------|-------|-------|-------|-------|-------|-------|----------------------------------|
| White 9003 | VTR9010 | Nero-Black | Grey 7001 | € /pc. | A mm. | B mm. | C mm. | D mm. | E mm. | F mm. | Kit serratura Door lock Optional |
| L 54 37 375 | L 54 37 033 | L 54 37 080 | L 54 37 079 | | 370 | 375 | 283 | 289 | 300 | 300 | M3512034 |

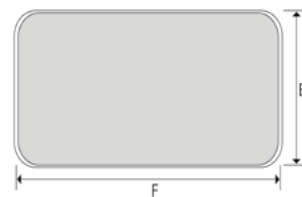
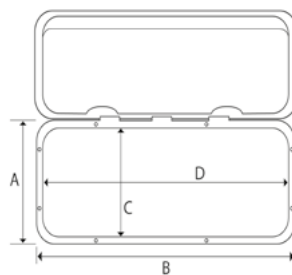

COMPLETO DI-COMLETE WITH



SUGGESTED ITEMS



Portello calpestabile impermeabile in AAS

Completo di fori per retine portaoggetti. Alta resistenza ai raggi UV.

Waterproof AAS walkable inspection hatch

Complete with internal holes for object-holder nets. Highly UV-resistant.

| Articolo - Item | Articolo - Item | Articolo - Item | Articolo - Item | € /pc. | A mm. | B mm. | C mm. | D mm. | E mm. | F mm. | Kit serratura Door lock Optional |
|-----------------|-----------------|-----------------|-----------------|--------|-------|-------|-------|-------|-------|-------|----------------------------------|
| White 9003 | VTR9010 | Nero-Black | Grey 7001 | € /pc. | A mm. | B mm. | C mm. | D mm. | E mm. | F mm. | Kit serratura Door lock Optional |
| L 54 46 510 | L 54 33 510 | L 54 80 510 | L 54 79 510 | | 460 | 510 | 373 | 433 | 390 | 445 | M3512034 |

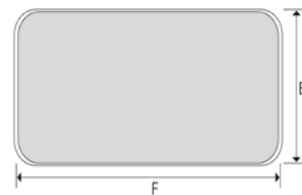
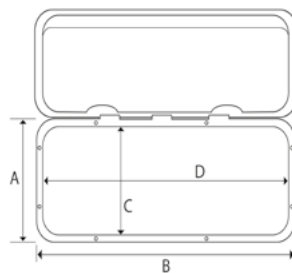

COMPLETO DI-COMLETE WITH



SUGGESTED ITEMS



Portello calpestabile impermeabile in AAS

Completo di fori per retine portaoggetti. Alta resistenza ai raggi UV.

Waterproof AAS walkable inspection hatch

Complete with internal holes for object-holder nets. Highly UV-resistant.

| Articolo - Item | Articolo - Item | Articolo - Item | Articolo - Item | € /pc. | A mm. | B mm. | C mm. | D mm. | E mm. | F mm. | Kit serratura Door lock Optional |
|-----------------|-----------------|-----------------|-----------------|--------|-------|-------|-------|-------|-------|-------|----------------------------------|
| White 9003 | VTR9010 | Nero-Black | Grey 7001 | € /pc. | A mm. | B mm. | C mm. | D mm. | E mm. | F mm. | Kit serratura Door lock Optional |
| L 54 35 606 | L 54 33 606 | L 54 34 606 | L 54 36 606 | | 353 | 606 | 266 | 520 | 283 | 530 | M3512034 |

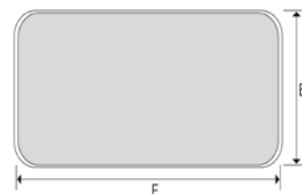
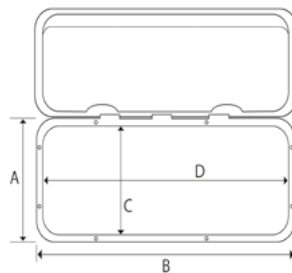

COMPLETO DI-COMLETE WITH



SUGGESTED ITEMS



Portello calpestabile in AAS

Waterproof AAS walkable inspection hatch

Completo di fori per retine VHF.

Complete with internal holes for object-holder nets. Highly UV-resistant.

| Articolo - Item | Articolo - Item | Articolo - Item | Articolo - Item | A | B | C | D | E | F | Kit serratura | |
|-----------------|-----------------|-----------------|-----------------|--------|-----|-----|-----|-----|-----|----------------|----------|
| White 9003 | VTR9010 | Nero-Black | Grey 7001 | mm. | mm. | mm. | mm. | mm. | mm. | Door lock Opt. | |
| L 54 27 375 | L 54 33 375 | L 54 80 375 | L 54 79 375 | € /pc. | 270 | 375 | 183 | 289 | 200 | 300 | M3512034 |



SUGGESTED ITEMS



COMPLETE WITH

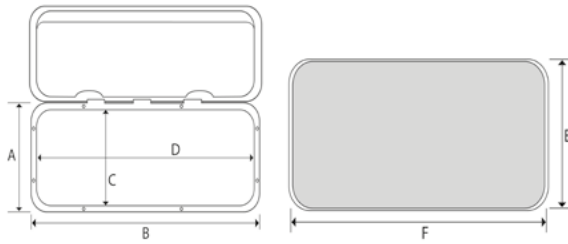

Portello calpestabile contenitore in AAS

Waterproof AAS walkable inspection hatch with box

Completo di fori per retine VHF. Contenitore in ABS.

Complete with internal holes for object-holder nets. Highly UV-resistant. ABS box.

| Articolo - Item | Articolo - Item | Articolo - Item | Articolo - Item | A | B | C | D | E | F | G | H | I | Kit serratura | |
|-----------------|-----------------|-----------------|-----------------|--------|-----|-----|-----|-----|-----|-----|-----|-----|----------------|----------|
| White 9003 | VTR9010 | Nero-Black | Grey 7001 | mm. | mm. | mm. | mm. | mm. | mm. | mm. | mm. | mm. | Door lock Opt. | |
| L 54 16 375 | L 54 16 033 | L 54 16 080 | L 54 16 079 | € /pc. | 270 | 375 | 183 | 289 | 270 | 170 | 160 | 210 | 305 | M3512034 |



SUGGESTED ITEMS



COMPLETE WITH

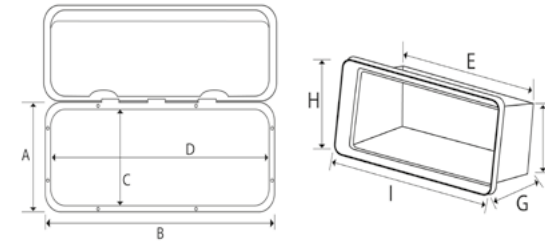

Portello calpestabile in AAS con viti coperte

Waterproof AAS walkable inspection hatch

Alta resistenza ai raggi UV.

Highly UV-resistant.

| Articolo - Item | Articolo - Item | Articolo - Item | Articolo - Item | A | B | C | D | E | F | Kit serratura | |
|-----------------|-----------------|-----------------|-----------------|--------|-----|-----|-----|-----|-----|----------------|----------|
| White 9003 | VTR9010 | Nero-Black | Grey 7001 | mm. | mm. | mm. | mm. | mm. | mm. | Door lock Opt. | |
| L 54 24 607 | L 54 33 607 | L 54 80 607 | L 54 79 607 | € /pc. | 243 | 607 | 162 | 521 | 173 | 530 | M3512034 |



SUGGESTED ITEMS



COMPLETE WITH

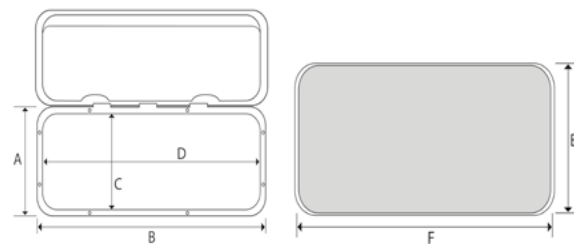

Portello calpestabile contenitore in AAS con viti coperte

Waterproof AAS walkable inspection hatch with box

Alta resistenza ai raggi UV.

Highly UV-resistant. ABS box.

| Articolo - Item | Articolo - Item | Articolo - Item | Articolo - Item | A | B | C | D | E | F | G | H | I | Kit serratura | |
|-----------------|-----------------|-----------------|-----------------|--------|-----|-----|-----|-----|-----|-----|-----|-----|----------------|----------|
| White 9003 | VTR9010 | Nero-Black | Grey 7001 | mm. | mm. | mm. | mm. | mm. | mm. | mm. | mm. | mm. | Door lock Opt. | |
| L 54 16 607 | L 54 16 637 | L 54 16 687 | L 54 16 677 | € /pc. | 243 | 607 | 162 | 521 | 513 | 151 | 182 | 177 | 542 | M3512034 |



SUGGESTED ITEMS



COMPLETE WITH

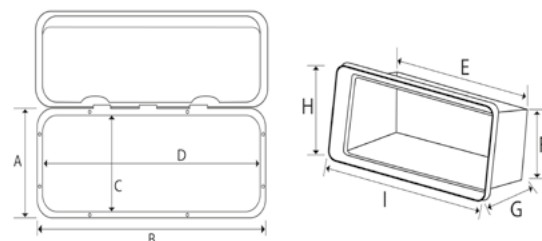



Sportello stagno con doppia maniglia

Fabbricato in ABS.
Colore bianco.
Resistente ai raggi UV.

Waterproof inspection hatch with double handle

Manufactured in ABS.
White colour.
UV resistant.

| Articolo - Item | €/pc. | Bocca Opening mm. | Esterne Outer mm. | Incasso Recess mm. | kg. |
|-----------------|-------|-------------------|-------------------|--------------------|-------|
| L 53 13 701 | | 275x275 | 376x376 | 294x196 | 1,350 |



Bauletto portaoggetti

Fabbricato in ABS grigio.
Completo di serratura.

Object holder

Manufactured in grey ABS.
Complete with lock.

| Articolo - Item | €/pc. | Esterne Outer mm. | Interne Inner mm. | kg. |
|-----------------|-------|-------------------|-------------------|-------|
| L 53 52 072 | | 340x140x190 | 315x100x165 | 0,550 |



ACCESSORI PER PORTELLI | ACCESSORIES FOR INSPECTION HATCHES



Serratura applicabile su tutti gli sportelli serie «Octopussy»

Modello completo di 2 chiavi.
Funzionamento a pulsante.

Lock for inspection hatch

Complete with 2 keys.
Operated by push-button.

| Articolo - Item | €/pc. |
|-----------------|-------|
| M 35 12 034 | |



M3533072



M3574072N-33072N-79072N

Maniglia di ricambio applicabile su tutti gli sportelli serie «Octopussy»

Realizzata in ABS.

Spare handle for inspection hatch

Manufactured in ABS.

| Articolo - Item | €/pc. | Lunghezza Length mm. | Colore Colour | kg. |
|-----------------|-------|----------------------|-----------------------|-----|
| M 35 33 072 | | 72 | VTR Ral 9010 | |
| M 35 74 072 N | | 72 | Bianco-White Ral 9003 | |
| M 35 33 072 N | | 72 | VTR Ral 9010 | |
| M 35 79 072 N | | 72 | Grigio-Grey Ral 7001 | |



VISITA IL NOSTRO
NUOVO WEBSITE



WWW.TREM.NET



TAPPI D'ISPEZIONE | DECK PLATES

Tappi d'ispezione

Chiusura a vite a perfetta tenuta stagna in quanto dotata di O-RING in gomma.

| Articolo - Item | Articolo - Item | Articolo - Item | Articolo - Item | €/pc. |
|-----------------|-----------------|-----------------|-----------------|-------------|
| White 9003 | Nero-Black | Grey 7001 | VTR9010 | |
| N 07 09 074 | N 07 09 080 | N 07 09 079 | N 07 09 033 | - |
| N 07 12 074 | N 07 12 080 | N 07 12 079 | N 07 12 033 | - |
| N 07 15 074 | N 07 15 080 | - | - | N 07 15 084 |

Deck plates

100% waterproof, screw-locking system, O-RING included.

| Articolo - Item | €/pc. | Ø Ext. mm. | Opening Ø mm. | Incasso Recess Ø mm. |
|------------------------|-------|------------|---------------|----------------------|
| Trasp. c/ghiera bianca | | | | |
| - | - | 147 | 102 | 115 |
| - | - | 172 | 125 | 140 |
| N 07 19 155 | | 205 | 152 | 165 |



N0709074-N0712074-N0715074



N0709079-N0712079



N0709080-N0712080-N0715080



N0709033-N0712033



N0715084



N0719155

TAPPI D'ISPEZIONE CALPESTABILI STAGNI | WATERPROOF WALKABLE DECK PLATES

Tappi d'ispezione calpestabili stagni

Chiusura a vite a perfetta tenuta stagna in quanto dotata di O-RING in gomma.

| Articolo - Item | Articolo - Item | €/pc. | Articolo - Item | Articolo - Item | €/pc. |
|-----------------|-----------------|-------|-----------------|-----------------|-------|
| White 9003 | Nero-Black | | Grey 7001 | VTR9010 | |
| N 07 74 162 | N 07 80 162 | | N 07 79 162 | N 07 33 162 | |
| N 07 74 187 | N 07 80 187 | | N 07 79 187 | N 07 33 187 | |
| N 07 74 222 | N 07 80 222 | | N 07 79 222 | N 07 33 222 | |

Waterproof walkable deck plates

100% waterproof, screw-locking system, O-RING included.

| Ø Esterno Outer Ø mm. | Ø Interno Inner Ø mm. | Taglio Cutout mm. |
|-----------------------|-----------------------|-------------------|
| 162 | 108 | 115 |
| 187 | 133 | 145 |
| 222 | 160 | 178 |



TASCHE LATERALI E NICCHIE | SIDE POCKETS



Tasca laterale porta-oggetti in ABS bianco

Tasche laterali porta-oggetti con copriviti autoadesivi.

Side pocket object-holder in white ABS

Complete with self-adhesive screw cover.

| Articolo - Item | €/pc. | Vano Compartment | ↳ Esterne Outer mm. | Vano utile Usable space mm. | Profondità Depth mm. |
|-----------------|-------|------------------|---------------------|-----------------------------|----------------------|
| N 01 24 052 | | Rigido-Stiff | 540x244 | 500x200x116 | 120 |

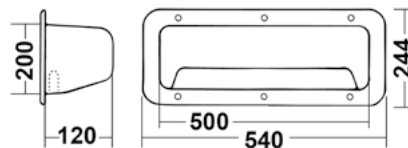

Cassonetto laterale porta-oggetti

Predisposto per montaggio casse stereo. In ABS bianco lucido. Montaggio a parete.

Side pocket object-holder

Suitable for speakers installation. Manufactured in white ABS.

| Articolo - Item | €/pc. | ↳ Esterne Outer mm. | ↳ Interne Inner mm. | Profondità Depth mm. | Per casse stereo For speakers Opt. |
|-----------------|-------|---------------------|---------------------|----------------------|------------------------------------|
| N 01 32 053 | | 535x320 | 495x280 | 116 | |



Vano ad incasso per tappo carburante

Fabbricate in nylon resistente agli idrocarburi.

Recessed mounting holder for deck filler

Manufactured in fuel resistant nylon.

| Articolo - Item | €/pc. | Mod. | AxB mm. (Incasso-Recess) | C mm. Sporgenza | DxE mm. Cornice-Frame | Colore Colour |
|-----------------|-------|--|--------------------------|-----------------|-----------------------|---------------------------------------|
| L 53 74 160 | | Gradino-Step | 120x150 | 98 | 165x200 | <input type="checkbox"/> Bianco-White |
| L 53 74 162 | | P/Tappo-Deck filler | 120x150 | 98 | 165x200 | <input type="checkbox"/> Bianco-White |
| L 53 33 162 | | P/Tappo-Deck filler | 120x150 | 98 | 165x200 | <input type="checkbox"/> Crema-Cream |
| L 53 74 161 | | Gradino c/sportello Step w/door | 120x150 | 98 | 165x200 | <input type="checkbox"/> Bianco-White |
| L 53 74 163 | | P/Tappo c/sportello Deck filler w/door | 120x150 | 98 | 165x200 | <input type="checkbox"/> Bianco-White |



SUGGESTED ITEMS

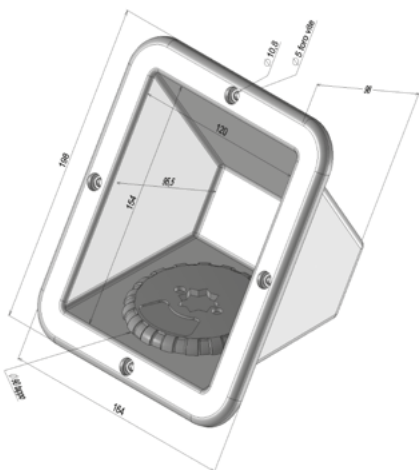

L5374160



L5374162-L5333162



L5374161



L5374163

Nicchia porta estintore con elastico di fermo

Modello fabbricato in ABS bianco.

Fire extinguisher compartement

Manufactured in white ABS.

| Articolo - Item | €/pc. | Mod. | ↳ Esterne Outer mm. | ↳ Interne Inner mm. |
|-----------------|-------|----------------------------|---------------------|---------------------|
| L 53 15 039 | | Senza sportello w/out door | 395x155 | 345x105 |



SUGGESTED ITEMS



Nicchia portaoggetti

Modello fabbricato in ABS bianco.

Object-holder compartement

Manufactured in white ABS.

| Articolo - Item | €/pc. | Mod. | ↳ Esterne Outer mm. | ↳ Interne Inner mm. |
|-----------------|-------|----------------------|---------------------|---------------------|
| L 53 18 011 | | Con sportello w/door | 230x150 | 180x105 |



COME SCEGLIERE LA TUA MOLLA? HOW TO CHOOSE YOUR GAS SPRING?

La scelta di una molla a gas dipende dalle specifiche applicazioni, dalle condizioni di lavoro previste dall'utente e dalla temperatura.
Di seguito riportiamo un chiaro esempio di calcolo della forza F1 a 20°C (ogni salto di 3°C comporta una variazione della forza dell'1%), per un'applicazione base (ad esempio un portello):

The choice of a gas spring depends on the specific applications, the working conditions provided by the user and the temperature.
Below is a clear example of calculation of the force F1 at 20°C (each jump of 3 °C involves a change in strength of 1%), for a base application (for example an inspection hatch):

$$F1 = \frac{P \times a}{b \times n}$$

In cui si deve intendere:

P = Peso portello (kg.)

a = Lunghezza portello / 2 (mm)

F1 = Reazione della molla a stelo esteso (kg.)

b = Distanza più breve tra il punto di attacco della molla e il fulcro del portello

n = Numero delle molle a gas impiegate

P = Hatch weight (kg.)

a = Hatch length / 2 (mm)

F1 = Spring force when the rod is extended (kg.)

b = Shorter distance between the attachment point of the spring and the fulcrum of the hatch

n = Number of gas springs used

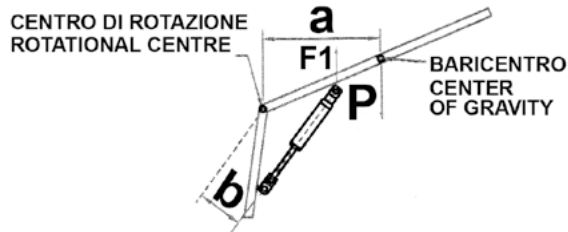

COMPASSI E MOLLE A GAS | GAS SPRINGS

Molle a gas in acciaio verniciato occhio-occhio

Realizzate con stelo in acciaio cromato a spessore e corpo rivestito con polveri epossidiche. Resistenti all'ambiente marino. Foro occhio 8 mm.

Painted steel gas springs eye-eye

With chromed steel rod and epoxy powder coated body. Marine environment resistant. Hole Ø 8 mm.

| Articolo - Item | €/pc. | Aperto-Open mm. | Corsa Stroke mm. | Reazione Force kg. (F1) | Corpo-Body Ø mm. | Stelo Rod Ø mm. |
|-----------------|-------|-----------------|------------------|-------------------------|------------------|-----------------|
| M 35 04 200 | | 200 | 60 | 4 | 19 | 8 |
| M 35 09 200 | | 200 | 60 | 9 | 19 | 8 |
| M 35 05 244 | | 244 | 88 | 5 | 19 | 8 |
| M 35 09 244 | | 244 | 88 | 9 | 19 | 8 |
| M 35 08 244 | | 244 | 88 | 18 | 19 | 8 |
| M 35 08 280 | | 280 | 110 | 8 | 19 | 8 |
| M 35 11 355 | | 355 | 130 | 11 | 19 | 8 |
| M 35 08 355 | | 355 | 130 | 18 | 19 | 8 |
| M 35 25 355 | | 355 | 130 | 25 | 19 | 8 |
| M 35 35 365 | | 365 | 135 | 35 | 19 | 8 |
| M 35 50 365 | | 365 | 135 | 50 | 19 | 8 |
| M 35 16 355 | | 370 | 140 | 16 | 19 | 8 |
| M 35 25 400 | | 400 | 160 | 25 | 19 | 8 |
| M 35 20 445 | | 445 | 180 | 20 | 19 | 8 |
| M 35 20 536 | | 535 | 220 | 20 | 19 | 8 |
| M 35 08 550 | | 550 | 229 | 8 | 19 | 8 |
| M 35 12 550 | | 550 | 229 | 12 | 19 | 8 |
| M 35 15 550 | | 550 | 229 | 15 | 19 | 8 |
| M 35 20 550 | | 550 | 229 | 20 | 19 | 8 |
| M 35 29 550 | | 550 | 229 | 29 | 19 | 8 |
| M 35 38 550 | | 550 | 229 | 38 | 19 | 8 |
| M 35 70 585 | | 585 | 250 | 70 | 22 | 10 |
| M 35 20 600 | | 600 | 255 | 20 | 19 | 8 |
| M 35 25 600 | | 600 | 255 | 25 | 19 | 8 |
| M 35 28 600 | | 600 | 255 | 28 | 19 | 8 |
| M 35 08 600 | | 600 | 255 | 36 | 19 | 8 |
| M 35 42 600 | | 600 | 255 | 42 | 19 | 8 |
| M 35 70 685 | | 685 | 300 | 70 | 22 | 10 |
| M 35 25 700 | | 700 | 300 | 25 | 19 | 10 |
| M 35 42 700 | | 700 | 300 | 42 | 19 | 10 |
| M 35 55 700 | | 700 | 300 | 55 | 19 | 10 |
| M 35 50 850 | | 850 | 360 | 50 | 19 | 10 |
| M 35 42 900 | | 900 | 360 | 42 | 27 | 12 |
| M 35 70 950 | | 950 | 400 | 70 | 19 | 10 |



SUGGESTED ITEMS



Supporto
Mounting plate

| Articolo - Item | €/pc. |
|-----------------|-------|
| M 35 32 000 | |

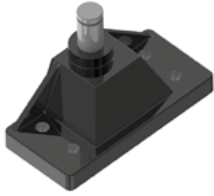
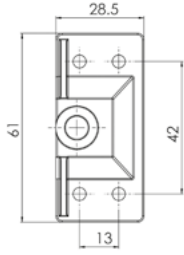

Supporto
Mounting plate

| Articolo - Item | €/pc. |
|-----------------|-------|
| M 35 32 001 | |

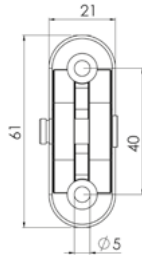

Piastra di fissaggio 90°
90° Mounting plate

Con perno filettato interno Ø 8 mm.
With inner threaded pin Ø 8 mm.

| Articolo - Item | €/pc. | A mm. | B mm. | C mm. |
|-----------------|-------|-------|-------|-------|
| M 35 32 002 | | 30 | 50 | 30 |

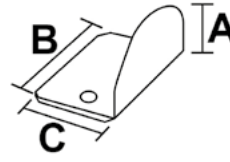

Piastra fissaggio piano
Flush-mount plate

Con perno filettato Ø 8 mm.
With threaded pin Ø 8 mm.

| Articolo - Item | €/pc. | A mm. | B mm. |
|-----------------|-------|-------|-------|
| M 35 32 003 | | 45 | 35 |

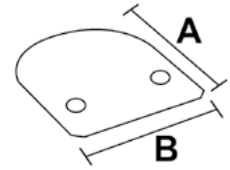

Piastra di fissaggio 90°
90° Mounting plate

Con perno filettato esterno Ø 8 mm.
With outer threaded pin Ø 8 mm.

| Articolo - Item | €/pc. | A mm. | B mm. | C mm. |
|-----------------|-------|-------|-------|-------|
| M 35 32 004 | | 30 | 50 | 30 |

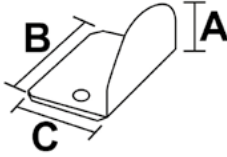

Piastra di fissaggio 90°
90° Mounting plate

Con sfera interna Ø 10 mm.
With inner sphere Ø 10 mm.

| Articolo - Item | €/pc. | A mm. | B mm. | C mm. |
|-----------------|-------|-------|-------|-------|
| M 35 32 005 | | 30 | 50 | 30 |

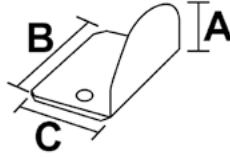

Piastra di fissaggio
Flush-mount plate

Con sfera Ø 10 mm.
With sphere Ø 10 mm.

| Articolo - Item | €/pc. | A mm. | B mm. |
|-----------------|-------|-------|-------|
| M 35 32 006 | | 60 | 30 |

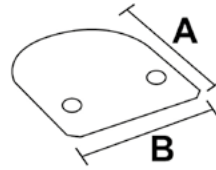

Piastra di fissaggio 90°
90° Mounting plate

Piastra forata con 3 fori: 6 mm., 8 mm., 10 mm.
Perforated plate with 3 holes: 6 mm, 8 mm, 10 mm.

| Articolo - Item | €/pc. | A mm. | B mm. | C mm. |
|-----------------|-------|-------|-------|-------|
| M 35 32 007 | | 30 | 50 | 30 |

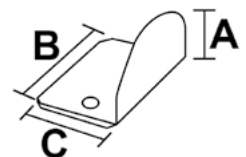

Testa a sfera
Sphere head

| Articolo - Item | €/pc. | F Ø | M Ø |
|-----------------|-------|-----|-----|
| M 35 32 009 | | 6 | 8 |

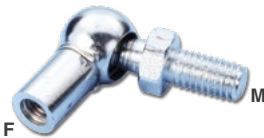

Testa per molla Ø 8 mm.
Head for gas spring Ø 8 mm.

| Articolo - Item | €/pc. | F Ø |
|-----------------|-------|-----|
| M 35 32 011 | | 8 |



Piastra di fissaggio 90°
90° Mounting plate

Con sfera Ø 10 mm.
With sphere Ø 10 mm.

| Articolo - Item | €/pc. | A mm. | B mm. | C mm. |
|-----------------|-------|-------|-------|-------|
| M 35 32 012 | | 30 | 50 | 30 |

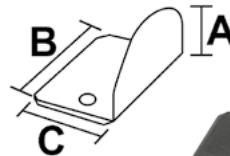

Piastra di fissaggio 90°
90° Mounting plate

Con perno filettato Ø 8 mm.
With threaded pin Ø 8 mm.

| Articolo - Item | €/pc. | A mm. | B mm. | C mm. |
|-----------------|-------|-------|-------|-------|
| M 35 32 013 | | 20 | 35 | 20 |

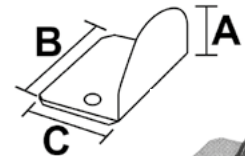

Basetta con perno

| Articolo - Item | €/pc. | Per testine-For head mm. |
|-----------------|-------|--------------------------|
| M 35 08 209 | | 8 |



Base with pin

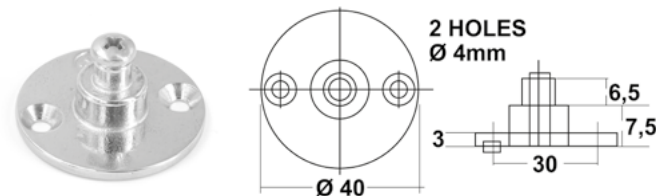

Basetta a forcella

| Articolo - Item | €/pc. | Per testine-For head mm. |
|-----------------|-------|--------------------------|
| M 35 08 210 | | 8 |



Base with fork

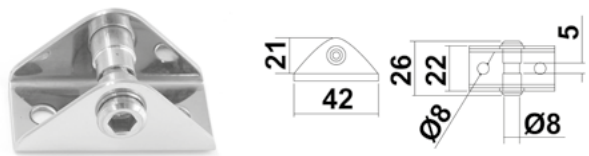

Molle a gas in acciaio inox occhio-occhio

Realizzate in acciaio inox Aisi 316. Con terminali ad occhio foro 8 mm.

Stainless steel gas springs eye-eye

Manufactured in Aisi 316 stainless steel. With eye terminals hole Ø 8 mm.

| Articolo - Item | €/pc. | Aperto-Open mm. | Corsa Stroke mm. | Reazione Force kg. | Corpo-Body Ø mm. | Stelo Rod Ø mm. |
|-----------------|-------|-----------------|------------------|--------------------|------------------|-----------------|
| M 36 05 250 | | 250 | 90 | 5 | 18 | 8 |
| M 37 10 250 | | 250 | 90 | 10 | 18 | 8 |
| M 37 18 250 | | 250 | 90 | 18 | 18 | 8 |
| M 36 18 250 | | 250 | 90 | 30 | 18 | 8 |
| M 36 12 355 | | 355 | 130 | 12 | 18 | 8 |
| M 37 18 355 | | 355 | 130 | 18 | 18 | 8 |
| M 37 25 355 | | 355 | 130 | 24 | 18 | 8 |
| M 36 18 355 | | 355 | 130 | 30 | 18 | 8 |
| M 37 15 430 | | 432 | 170 | 15 | 18 | 8 |
| M 37 25 430 | | 432 | 170 | 25 | 18 | 8 |
| M 37 35 430 | | 432 | 170 | 35 | 18 | 8 |
| M 37 45 430 | | 432 | 170 | 45 | 18 | 8 |
| M 36 14 500 | | 500 | 210 | 14 | 18 | 8 |
| M 36 20 501 | | 500 | 210 | 20 | 18 | 8 |
| M 36 30 500 | | 500 | 210 | 30 | 18 | 8 |
| M 36 40 500 | | 500 | 210 | 40 | 18 | 8 |
| M 36 50 500 | | 500 | 210 | 50 | 18 | 8 |
| M 37 20 600 | | 600 | 255 | 20 | 18 | 8 |
| M 37 30 600 | | 600 | 255 | 30 | 18 | 8 |
| M 36 20 600 | | 600 | 255 | 40 | 18 | 8 |
| M 36 50 600 | | 600 | 255 | 50 | 18 | 8 |
| M 36 25 701 | | 700 | 300 | 25 | 22 | 10 |
| M 36 35 700 | | 700 | 300 | 35 | 22 | 10 |
| M 36 25 700 | | 700 | 300 | 45 | 22 | 10 |
| M 36 55 700 | | 700 | 300 | 55 | 22 | 10 |
| M 36 45 900 | | 900 | 380 | 45 | 22 | 10 |
| M 36 60 900 | | 900 | 380 | 60 | 22 | 10 |
| M 37 05 380 | | 380 | 150 | 5 | 15 | 6 |
| M 37 10 380 | | 380 | 150 | 10 | 18 | 8 |
| M 36 38 350 | | 550 | 230 | 35 | 18 | 8 |
| M 36 20 500 | | 550 | 230 | 38 | 18 | 8 |
| M 36 38 500 | | 550 | 230 | 64 | 18 | 8 |
| M 37 35 600 | | 600 | 255 | 35 | 18 | 8 |
| M 36 36 600 | | 600 | 255 | 60 | 18 | 8 |



SUGGESTED ITEMS



Molle a gas in acciaio inox testa a sfera

Terminali a sfera in acciaio inox con perno filettato

Stainless steel gas springs with sphere head

Stainless steel sphere terminals with threaded pin.

| Articolo - Item | €/pc. | Aperto-Open mm. | Corsa Stroke mm. | Reazione Force kg. | Corpo-Body Ø mm. | Stelo-Rod Ø mm. | Filetto M |
|-----------------|-------|-----------------|------------------|--------------------|------------------|-----------------|-----------|
| M 37 10 381 | | 380 | 150 | 10 | 15 | 6 | 5 |
| M 37 35 381 | | 380 | 150 | 35 | 15 | 6 | 5 |
| M 37 25 601 | | 600 | 255 | 25 | 18 | 8 | 8 |
| M 37 50 601 | | 600 | 255 | 50 | 18 | 8 | 8 |



SUGGESTED ITEMS



Compasso in acciaio inox a molla

Realizzato in acciaio inox. Completo di piastrine per il fissaggio.

Stainless steel hatch stay

Manufactured in stainless steel with mounting plates.

| Articolo - Item | €/pc. | Lunghezza-Length mm. | Molla-Spring Ø mm. | kg. |
|-----------------|-------|----------------------|--------------------|-------|
| M 35 11 210 | | 210 | 11 | 0,080 |
| M 35 11 260 | | 260 | 14 | 0,160 |

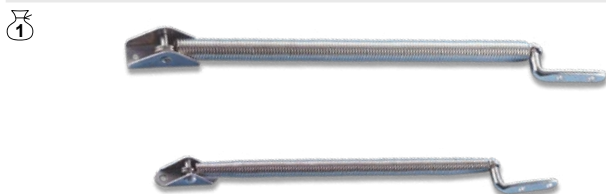

Compasso telescopico in acciaio inox

Realizzato in acciaio inox con possibilità di bloccaggio in qualsiasi posizione.

Stainless steel telescopic hatch stay

Manufactured in stainless steel. Locking possible in every position.

| Articolo - Item | €/pc. | Lunghezza-Length mm. | kg. |
|-----------------|-------|----------------------|-------|
| M 35 00 365 | | 200-365 | 0,200 |

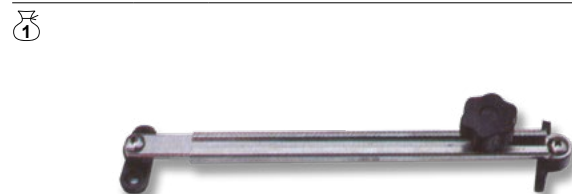

PASSI UOMO IN PLASTICA | PLASTIC PORTHOLES

Passo d'uomo rettangolare

Realizzato in metacrilato bianco.
Apribile dall'esterno o dall'interno.
Con vetro temperato.
Privo di controflangia.

Rectangular porthole

Manufactured in white ABS.
Its design allows to gain access both outside
and inside. With tempered glass.
Without counterflange.

| Articolo - Item | €/pc. | mm. | mm. | kg. |
|-----------------|-------|---------|---------|-------|
| N 07 63 063 | | 365x475 | 425x540 | 4,290 |



- Dimensioni interne
Inner size
 Dimensioni esterne
Outer size

Passo d'uomo tondo

Realizzato in metacrilato bianco.
Con vetro temperato.
Completo di controflangia.

Round porthole

Manufactured in white methacrylate.
With tempered glass.
With counterflange.

| Articolo - Item | €/pc. | mm. | mm. | kg. |
|-----------------|-------|-----|-----|-------|
| N 07 00 624 | | 552 | 624 | 7,870 |



- Dimensioni interne
Inner size
 Dimensioni esterne
Outer size

OBLÒ E PASSI UOMO ORIGINALI «BSI» | PORTHOLES «BSI»



Portello per barche a motore e vela

La serie di portelli «Moonlight» è realizzata con la controflangia in materiale plastico.
La finitura standard della superficie è in alluminio anodizzato.

Porthole for power boats and sail boats

«Moonlight» hatches series is made with the plastic counterflange.
The standard finish of the surface is made with anodized aluminum.

RETTANGOLARE - RECTANGULAR

| Articolo - Item | €/pc. | mm. | mm. | kg. |
|-----------------|-------|-------------|---------|-------|
| N 07 15 405 | | 405x155xR52 | 423x173 | 1,500 |

CIRCOLARE - ROUND

| Articolo - Item | €/pc. | mm. | mm. | mm. | kg. |
|-----------------|-------|-----|-----|-----|-------|
| N 07 25 518 | | 518 | 573 | 25 | 1,500 |



N0715405



N0725518

- Dimensioni incasso
Recess size
 Dimensioni esterne
Outer size

OBLÒ IN PLASTICA | PLASTIC PORTHOLES

Oblò in nylon composito

Oblò rettangolare. Cornice in plastica. Vetro in acrilico.
Completi di controcornice. Collo altezza 30 mm.

Nylon porthole

Rectangular shape porthole. Plastic frame. Acrylic glass.
With counterflange. Base height 30 mm.

| Articolo - Item | €/pc. | Colore-Colour | Lunghezza-Length mm. | H mm. | mm. | kg. |
|-----------------|-------|--|----------------------|-------|---------|-------|
| N 07 74 400 | | <input type="checkbox"/> Bianco-White | 400 | 200 | 320x128 | 1,820 |
| N 07 80 400 | | <input checked="" type="checkbox"/> Nero-Black | 400 | 200 | 320x128 | 1,820 |



Oblò ovale

Realizzato in metacrilato bianco.
Con vetro temperato. Completo di zanzariera.

Oval porthole

Manufactured in white methacrylate.
With tempered glass. Complete with mosquito net.

| Articolo - Item | €/pc. | Controflangia Counter-flange | Colore-Colour | mm. | mm. | kg. |
|-----------------|-------|---------------------------------|---------------------------------------|---------|---------|-------|
| N 07 47 021 | | No | <input type="checkbox"/> Bianco-White | 390x130 | 475x240 | 1,600 |
| N 07 47 082 | | Si-Yes | <input type="checkbox"/> Bianco-White | 390x130 | 475x240 | 1,340 |



N0747021



N0747082

- Dimensioni interne
Inner size
 Dimensioni esterne
Outer size

Tendine oscuranti «Sunset Curtain» complete di gancio d'arresto

Con telaio in acciaio inox verniciato con resine epossidiche. Molle in acciaio inox. Tessuto oscurante in poliestere, con lato esterno metallizzato argento al fine di garantire di notte oscuramento totale e di giorno la riflessione dei raggi solari. Si montano sotto i passi uomo o davanti agli obli.

Awningblind «Sunset Curtain» with stopping hook

Frame made in stainless steel, painted with epoxy powder. Springs in stainless steel. Polyester fabric with outer silver metallized side. Easy mounting under the manholes or in front of the portholes.

| Articolo - Item | €/pc. | L max | Fori Holes mm. | Telo-Fabrics mm. (LxH) | kg. |
|-----------------|-------|-------|-------------------------------|------------------------|-------|
| V 25 40 360 | | 450 | 410 | 360x440 | 0,260 |
| V 25 50 450 | | 540 | 500 | 450x540 | 0,340 |
| V 25 60 500 | | 590 | 550 | 500x620 | 0,390 |
| V 25 65 550 | | 640 | 600 | 550x680 | 0,440 |
| V 25 78 680 | | 770 | 730 | 680x810 | 0,540 |
| V 25 37 970 | | 975 | 935 | 910x370 | 0,520 |
| V 25 74 045 | | | Gancio di ricambio-Spare hook | | 0,110 |



«Combi Curtain»

Fabbricata in plastica di alta qualità. Colore bianco Ral 9010. Design elegante. Basso profilo (27 mm.). Viti a scomparsa. Dotata di tendina avvolgibile e zanzariera utilizzabili in combinazione con il supporto di un fermo magnetico.

«Combi Curtain»

Made of high quality plastic in white colour Ral 9010. Elegant design, low profile (only 27 mm.), hidden screws. Equipped with roller blind and mosquito net that can be used even in combination with the aid of a magnetic catch.

| Articolo - Item | €/pc. | Indicata per boccaporto Suitable for hatch | mm. (Esterne-Outer) | mm. (Luce-Light A-B) | kg. |
|-----------------|-------|--|---------------------|----------------------|-------|
| V 25 74 442 | | Lewmar 44-Bomar 1080 | 570x570 | 470x470 | 1,450 |



Tendina oscurante 100%

Provista di zanzariera mobile e cornice elegante in plastica. Modello compatto in colore crema.

Sunset curtain 100%

Easy mounting under the manholes or in front of the portholes. With mosquito net and plastic frame. Compact model in cream colour.

| Articolo - Item | €/pc. | mm. (Luce-Light) | Indicata per boccaporto Suitable for hatch | kg. |
|-----------------|-------|------------------|--|-------|
| V 25 88 044 | | 470x470 | Lewmar 44-Bomar 1080 | 1,400 |



Manica a vento per boccaporti

Fabbricata in tessuto SPI impermeabile. Particolarmente utile quando la barca è ormeggiata, in quanto la manica a vento si gonfia incanalando l'aria all'interno della cabina. Provista di stecche.

Hatch wind scoop

Made of waterproof SPI fabric. Forcing the slightest breeze, useful to keep your cabin cool and comfortable. Complete with battens.

| Articolo - Item | €/pc. | Boccaporto-Hatch | | kg. |
|-----------------|-------|------------------|-------|-------|
| | | L mm. | H mm. | |
| N 07 50 125 | | 500 | 1250 | 0,600 |
| N 07 60 135 | | 600 | 1350 | 0,650 |

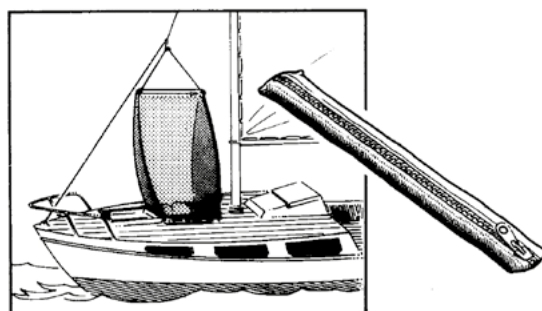



TENDALINI BIMINI | BIMINI TOPS

Tendalino roll-bar

Para-sole, para-acqua, telescopico per roll-bar. Completo di tubo Ø 22/25 mm. in acciaio inox Aisi 316, sacca di custodia, 2 supporti a forcella in acciaio inox, 10 mt. di cima. Si adatta all'altezza del roll-bar e può rimanere sempre montata anche quando è chiusa. Completa di custodia di protezione. Roll-bar non compreso.

Bimini top for roll-bar

Telescopic bimini top for roll-bar application. Complete with Aisi 316 stainless steel pipe Ø 22/25 mm., 2 stainless steel installation forks, 10 mt. rope. Complete with carry bag. Roll-bar not included.

| Articolo - Item | €/pc. | Colore-Colour | A mm. | B mm. | C mm. | Ø mm. | Confezione-Packing | mm. | kg. |
|-----------------|-------|---------------------------------------|-------|-------|-------|-------|--------------------|-----|-------|
| O 28 12 145 | | <input type="checkbox"/> Bianco-White | 120 | 205 | 145 | 25/22 | 31x9x122 | | 6,900 |
| O 28 13 155 | | <input type="checkbox"/> Bianco-White | 130 | 235 | 155 | 25/22 | 31x9x132 | | 7,300 |
| O 28 13 170 | | <input type="checkbox"/> Bianco-White | 130 | 235 | 170 | 25/22 | 31x9x137 | | 7,600 |
| O 28 13 190 | | <input type="checkbox"/> Bianco-White | 130 | 235 | 190 | 25/22 | 31x9x152,5 | | 7,700 |



UV RESISTANT made by

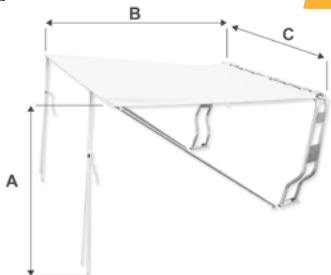

SUGGESTED ITEM

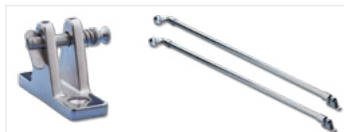

BASLETTE-BASES
(pag.338)

COPPIA BARRE-BARS
(pag. 339)

TENDALINI CAGNARO | SUN AWNINGS

Tendalino Cagnaro

Per imbarcazioni a vela. In tessuto bianco, 100% poliestere provvisto di anelli in acciaio inox lungo il perimetro per il fissaggio alle draglie e anelli nella parte centrale per il fissaggio in alto. Altamente resistente ai raggi UV e agli agenti corrosivi.

Sailing boat sun awning

Manufactured in 100% polyester white fabric with stainless steel rings for guardrails fastening. Highly UV resistant.

| Articolo - Item | €/pc. | Lunghezza-Length mt. | Larghezza-Width mt. | kg. |
|-----------------|-------|----------------------|---------------------|-----|
| O 24 25 030 | | 2,60 | 2,30 | |
| O 24 30 035 | | 3,10 | 2,90 | |



made by



TENDALINI AISI 316 | AISI 316 BIMINI TOPS

Tendalino «Luxury Inox»

Para-sole, para-acqua. Telaio a 3 archi in acciaio inox Aisi 316L Ø 22 mm. Snodi in acciaio inox, tessuto in poliestere 100% spalmato in vinile. Completo di ogni accessorio. Velocità massima di utilizzo 60 km/h.

Bimini top «Luxury Inox»

3 arches frame manufactured in Aisi 316L stainless steel. Pipes Ø 22 mm. Stainless steel joints, 100% polyester fabric. Complete with fitting accessories. Max speed 30 knots.

| Articolo - Item | €/pc. | Articolo - Item | €/pc. | A cm. | B cm. | C cm. | kg. |
|---------------------------------------|-------|-----------------------------------|-------|-------|-------|-------|-----|
| <input type="checkbox"/> Bianco-White | | <input type="checkbox"/> Blu-Blue | | | | | |
| O 27 14 185 | - | | - | 185 | 140 | 200 | |
| O 27 14 200 | - | | - | 200 | 140 | 200 | |
| O 27 14 215 | - | | - | 215 | 140 | 200 | |
| O 27 14 230 | | O 26 14 230 | | 230 | 140 | 235 | |
| O 27 14 245 | | | | 245 | 140 | 235 | |



AISI 316 made by

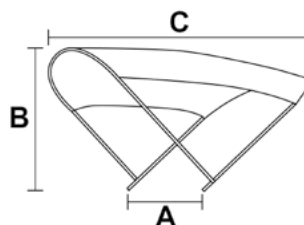
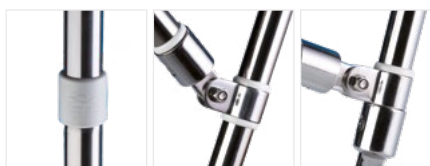

SUGGESTED ITEM



BASLETTE-BASES
(pag.338)

COPPIA BARRE-BARS
(pag. 339)

T-TOP in alluminio verniciato bianco

Fabbricato in tubo anodizzato e verniciato bianco a polveri Ø 32 mm.
Tessuto in poliestere blu impermeabile ed UV resistente.
Velocità massima consentita con telo installato: 30 nodi (TESTATO).

Universal aluminium T-TOP

Manufactured in anodized aluminium and white powder coated pipe Ø 32 mm.
T-TOP fabric made in waterproof and UV resistant polyester blue colour.
Max speed resistance: 30 knots (TESTED).

| Articolo - Item | €/pc. | A mm. | Max A1 mm. | B mm. | C mm. | kg. |
|-----------------|-------|-------|------------|-------|-------|-----|
| O 29 02 120 | | 1700 | 900 | 1200 | 2100 | |
| O 29 02 140 | | 1700 | 1100 | 1400 | 2100 | |

UV RESISTANT WATERPROOF made by **NEW**

COMPLETO DI-COMLETE WITH SUGGESTED ITEM



T·TOP

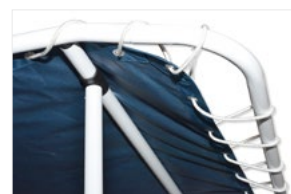
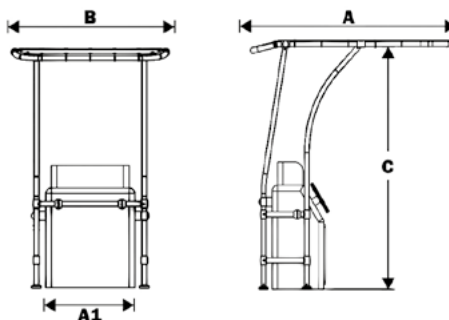

ACCESSORI PER T-TOP | T-TOP ACCESSORIES

Teli di ricambio per T-TOP

Realizzati in poliestere UV resistant.

| Articolo - Item | €/pc. | Articolo - Item | €/pc. |
|-----------------|-------|-----------------|-------|
| ■ Bianco-White | | ■ Blu-Blue | |
| O 29 74 120 | | O 29 75 120 | |
| O 29 74 140 | | O 29 75 140 | |

Spare fabric for T-TOP

Manufactured in UV-resistant polyester.

| Indicato per-Suitable for T-TOP | kg. |
|---------------------------------|-----|
| O2902120 | |
| O2902140 | |

NEW



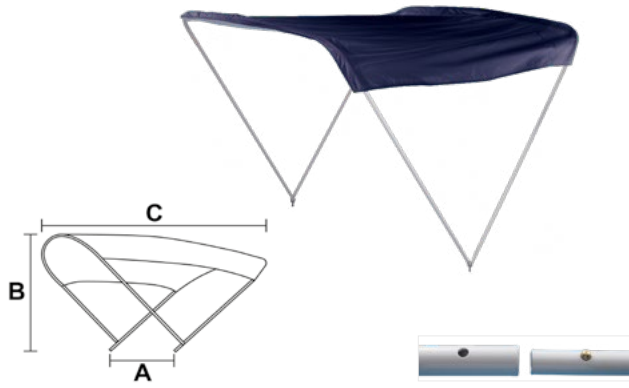

Tendalini a 2 archi blu

Para-sole, para-acqua. Telaio a 2 archi in alluminio verniciato bianco Ø 20 mm. Tessuto resistente alla luce, al salino e agli idrocarburi. Completato di ogni accessorio.

Bimini tops blue 2 arches

2 arches frame manufactured in anodised aluminium white painted. Pipes Ø 20 mm. Marine environment resistant. Complete with fitting accessories.

| Articolo - Item | €/pc. | A cm. | B cm. | C cm. |
|-----------------|-------|-------|-------|-------|
| Blu-Blue | | | | |
| O 29 02 130 | | 130 | 110 | 180 |
| O 29 02 150 | | 150 | 110 | 180 |



COMPLETO DI-COMLETE WITH

SUGGESTED ITEM

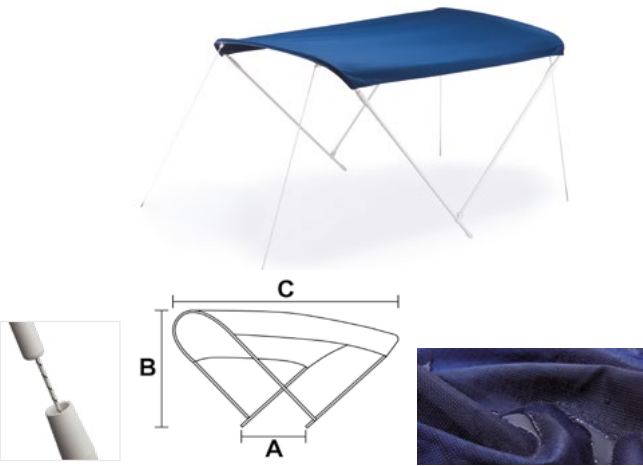

Tendalini a 2 archi blu

Para-sole, para-acqua. Telaio a 2 archi in alluminio verniciato bianco con tubo Ø 20 mm. Snodi in nylon bianco caricato fibra di vetro resistente agli agenti corrosivi marini e tessuto in poliestere resinato di colore blu resistente ai raggi UV. Universale per ogni tipo di imbarcazione. Fornito in un kit di rapido assemblaggio.

Bimini tops blue 2 arches

2 arches frame manufactured in anodised aluminium white painted. Pipes Ø 20 mm. Joints manufactured in white nylon highly resistant. Polyester fabric. Marine environment resistant. Complete with fitting accessories.

| Articolo - Item | €/pc. | Articolo - Item | €/pc. | A cm. | B cm. | C cm. |
|-----------------|-------|----------------------------|-------|-------|-------|-------|
| Blu-Blue | | Blu-Blue 100% UV resistant | | | | |
| O 29 02 135 | | O 39 02 135 | | 130 | 110 | 180 |
| O 29 02 155 | | - | | 150 | 110 | 180 |



COMPLETO DI-COMLETE WITH

SUGGESTED ITEM

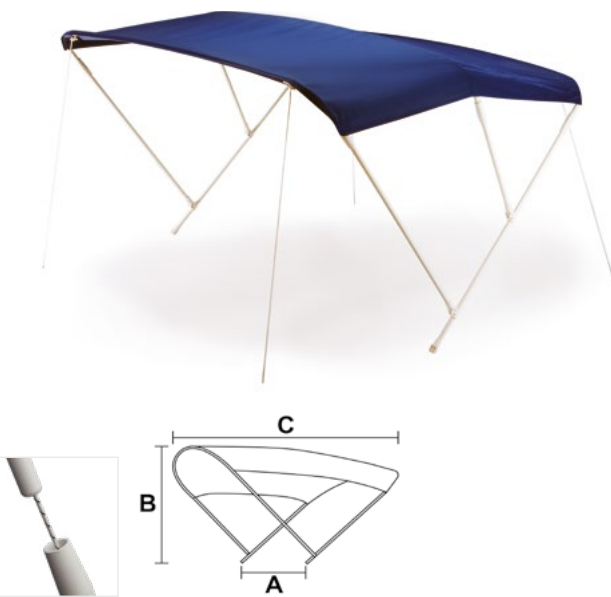

Tendalini a 3 archi blu

Para-sole, para-acqua. Telaio a 3 archi in alluminio verniciato bianco con tubo Ø 20 mm. Snodi in nylon bianco caricato fibra di vetro resistente agli agenti corrosivi marini e tessuto in poliestere resinato di colore blu resistente ai raggi UV. Universale per ogni tipo di imbarcazione. Fornito in un kit di rapido assemblaggio.

Bimini tops blue 3 arches

3 arches frame manufactured in anodised aluminium white painted. Pipes Ø 20 mm. Joints manufactured in white nylon highly resistant. Polyester fabric. Marine environment resistant. Complete with fitting accessories.

| Articolo - Item | €/pc. | Articolo - Item | €/pc. | A cm. | B cm. | C cm. |
|-----------------|-------|----------------------------|-------|-------|-------|-------|
| Blu-Blue | | Blu-Blue 100% UV resistant | | | | |
| O 29 03 170 | | - | | 170 | 110 | 180 |
| O 29 03 185 | | O 39 03 185 | | 185 | 110 | 180 |
| O 29 03 200 | | O 39 03 200 | | 200 | 110 | 180 |
| O 29 03 225 | | - | | 225 | 110 | 180 |
| - | | O 39 04 150 | | 150 | 140 | 180 |
| O 29 04 170 | | O 39 04 170 | | 170 | 140 | 180 |
| O 29 04 185 | | O 39 04 185 | | 185 | 140 | 180 |
| O 29 04 200 | | O 39 04 200 | | 200 | 140 | 180 |
| O 29 04 225 | | O 39 04 225 | | 225 | 140 | 180 |



COMPLETO DI-COMLETE WITH

SUGGESTED ITEM

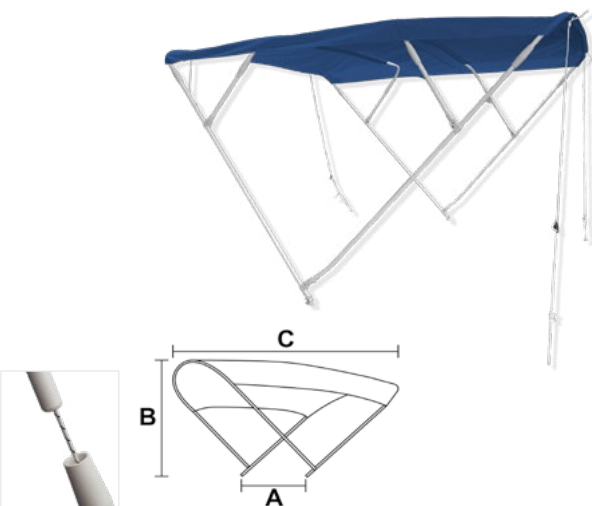

Tendalini a 4 archi blu

Para-sole, para-acqua. Telaio a 4 archi in lega leggera colore bianco Ø 20 mm. Snodi in nylon rinforzato, piedini di base in acciaio inox Aisi 316, attacchi alla coperta in nylon/inox. Tessuto blu in poliestere 100% spalmato in vinile. Completo di ogni accessorio. Velocità massima di utilizzo 60 km/h.

Bimini tops blue 4 arches

4 arches frame manufactured in anodised aluminium white painted. Pipes Ø 20 mm. Joints manufactured in reinforced nylon. Base supports in Aisi 316 stainless steel. Polyester fabric. Marine environment resistant. Complete with fitting accessories.

| Articolo - Item | €/pc. | A cm. | B cm. | C cm. |
|-----------------|-------|---------|-------|-------|
| Blu-Blue | | | | |
| O 29 44 165 | | 165-175 | 150 | 250 |
| O 29 44 180 | | 180-190 | 150 | 250 |
| O 29 44 190 | | 190-200 | 150 | 250 |
| O 29 44 210 | | 210-220 | 150 | 250 |
| O 29 44 225 | | 225-235 | 150 | 250 |



COMPLETO DI-COMLETE WITH

SUGGESTED ITEM



Tendalini a 2 archi bianchi

Para-sole, para-acqua. Telaio a 2 archi in alluminio verniciato bianco Ø 20 mm. Tessuto resistente alla luce, al salino e agli idrocarburi. Completi di ogni accessorio.

| Articolo - Item | € /pc. | A cm. | B cm. | C cm. |
|-----------------|--------|-------|-------|-------|
| Bianco-White | | | | |
| O 28 02 130 | | 130 | 110 | 180 |
| O 28 02 150 | | 150 | 110 | 180 |

Bimini tops white 2 arches

2 arches frame manufactured in anodised aluminium white painted. Pipes Ø 20 mm. Marine environment resistant. Complete with fitting accessories.



COMPLETO DI-COMLETE WITH



SACCA-BAG (pag. 340)

KIT (pag. 340)

TELO-FABRIC (pag. 340)

SUGGESTED ITEM



SUCTION DISC (pag. 340)

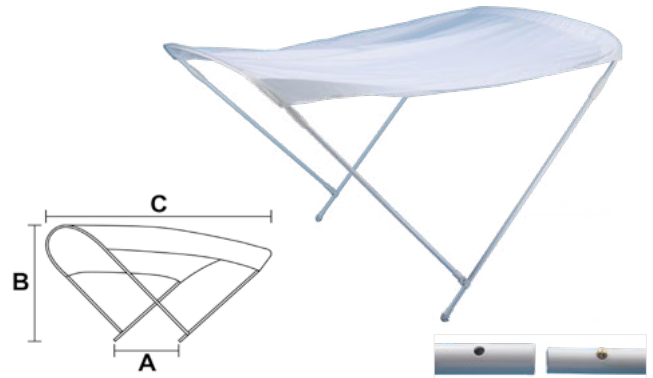

Tendalini a 2 archi bianchi

Para-sole, para-acqua. Telaio a 2 archi in alluminio verniciato bianco con tubo Ø 20 mm. Snodi in nylon bianco caricato fibra di vetro resistente agli agenti corrosivi marini e tessuto in poliestere resinato di colore bianco resistente ai raggi UV. Universale per ogni tipo di imbarcazione. Fornito in un kit di rapido assemblaggio.

Bimini tops white 2 arches

2 arches frame manufactured in anodised aluminium white painted. Pipes Ø 20 mm. Joints manufactured in white nylon highly resistant. Polyester fabric. Marine environment resistant. Complete with fitting accessories.

| Articolo - Item | € /pc. | A cm. | B cm. | C cm. |
|-----------------|--------|-------|-------|-------|
| Bianco-White | | | | |
| O 28 02 135 | | 130 | 110 | 180 |
| O 28 02 155 | | 150 | 110 | 180 |
| O 28 02 175 | | 170 | 110 | 180 |



COMPLETO DI-COMLETE WITH

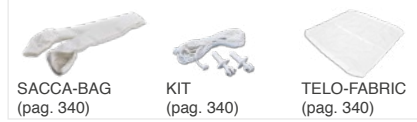

SACCA-BAG (pag. 340)

KIT (pag. 340)

TELO-FABRIC (pag. 340)

SUGGESTED ITEM



SUCTION DISC (pag. 340)

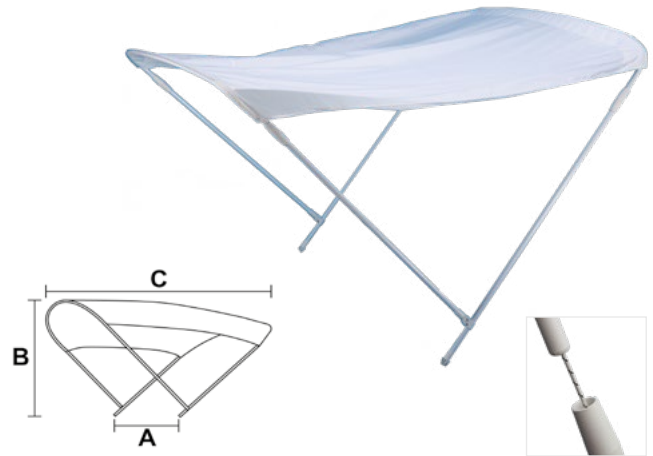

Tendalini a 3 archi bianchi

Para-sole, para-acqua. Telaio a 3 archi in alluminio verniciato bianco con tubo Ø 20 mm. Snodi in nylon bianco caricato fibra di vetro resistente agli agenti corrosivi marini e tessuto in poliestere resinato resistente ai raggi UV. Universale per ogni tipo di imbarcazione. Fornito in un kit di rapido assemblaggio.

Bimini tops white 3 arches

3 arches frame manufactured in anodised aluminium white painted. Pipes Ø 20 mm. Joints manufactured in white nylon highly resistant. Polyester fabric. Marine environment resistant. Complete with fitting accessories.

| Articolo - Item | € /pc. | A cm. | B cm. | C cm. |
|-----------------|--------|-------|-------|-------|
| Blu-Blue | | | | |
| O 28 03 170 | | 170 | 110 | 180 |
| O 28 03 185 | | 185 | 110 | 180 |
| O 28 03 200 | | 200 | 110 | 180 |
| O 28 03 225 | | 225 | 110 | 180 |
| O 28 04 150 | | 150 | 140 | 180 |
| O 28 04 170 | | 170 | 140 | 180 |
| O 28 04 185 | | 185 | 140 | 180 |
| O 28 04 200 | | 200 | 140 | 180 |
| O 28 04 225 | | 225 | 140 | 180 |



COMPLETO DI-COMLETE WITH



BORSA-BAG (pag. 340)

KIT (pag. 340)

TELO-FABRIC (pag. 340)

SUGGESTED ITEM



SUCTION DISC (pag. 340)

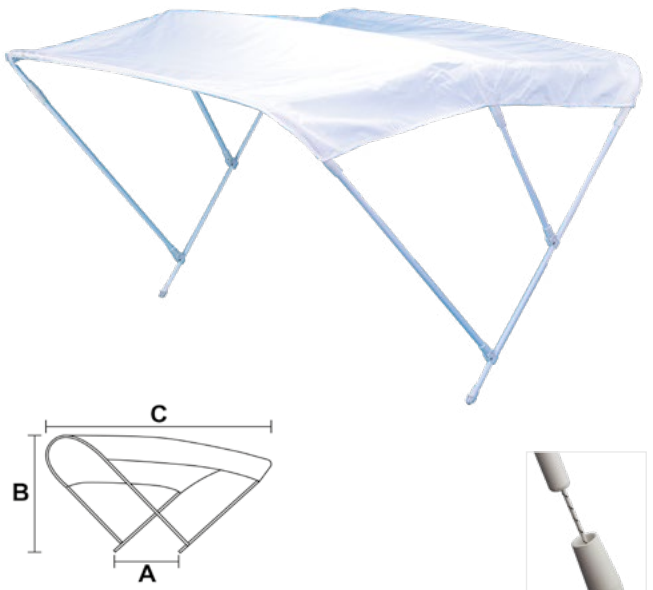

Tendalini a 4 archi bianchi

Para-sole, para-acqua. Telaio a 4 archi in lega leggera colore bianco Ø 20 mm. Snodi in nylon rinforzato, piedini di base in acciaio inox Aisi 316, attacchi alla coperta in nylon/inox. Tessuto bianco in polacryl 100% spalmato in vinile. Completo di ogni accessorio. Velocità massima di utilizzo 60 km/h.

Bimini tops white 4 arches

4 arches frame manufactured in anodised aluminium white painted. Pipes Ø 20 mm. Joints manufactured in reinforced nylon. Base supports in Aisi 316 stainless steel. Polyester fabric. Marine environment resistant. Complete with fitting accessories.

| Articolo - Item | € /pc. | A cm. | B cm. | C cm. |
|-----------------|--------|---------|-------|-------|
| Blu-Blue | | | | |
| O 28 44 165 | | 165-175 | 150 | 250 |
| O 28 44 180 | | 180-190 | 150 | 250 |
| O 28 44 190 | | 190-200 | 150 | 250 |
| O 28 44 210 | | 210-220 | 150 | 250 |
| O 28 44 225 | | 225-235 | 150 | 250 |



COMPLETO DI-COMLETE WITH



SACCA-BAG (pag. 340)

KIT (pag. 340)

TELO-FABRIC (pag. 340)

SUGGESTED ITEM



SUCTION DISC (pag. 340)

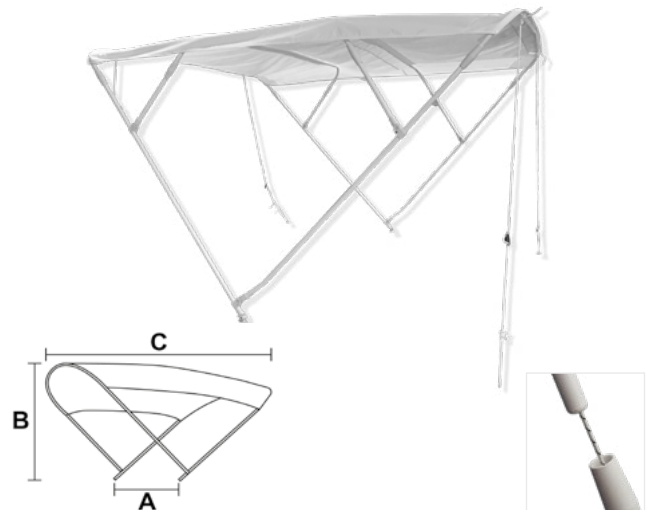

ACCESSORI TENDALINI | BIMINI TOP ACCESSORIES

Cappuccio

End cap

| Articolo - Item | €/pc. | Ø mm. |
|-----------------|-------|-------|
| O 24 32 401 | | 22 |
| O 24 32 015 | | 25 |

 **AISI 316**



Snodo a forcella

Fork joint

| Articolo - Item | €/pc. | Ø mm. |
|-----------------|-------|-------|
| O 24 32 405 | | 22 |
| O 24 32 030 | | 25 |

 **AISI 316**

Supporto forcella
90°

90° Fork joint

| Articolo - Item | €/pc. |
|-----------------|-------|
| O 24 32 090 | |

 **AISI 316**

Supporto forcella
90° c/perno a molla90° Fork joint
with spring pin

| Articolo - Item | €/pc. |
|-----------------|-------|
| O 24 32 177 | |

 **AISI 316**

Supporto forcella
inclinata con perno
a mollaSlanting fork joint
with spring pin

| Articolo - Item | €/pc. |
|-----------------|-------|
| O 24 32 178 | |

 **AISI 316**

Supporto forcella
90° attacco a tubo90° Fork joint with
spring pin for pipe

| Articolo - Item | €/pc. |
|-----------------|-------|
| O 24 32 179 | |

 **AISI 316**

Cerniera a 90° con
perno sfilabile90° articulated joint
with removable pin

| Articolo - Item | €/pc. | Per tubo | |
|-----------------|-------|----------------|-------|
| | | For pipe Ø mm. | kg. |
| O 24 30 106 | | 30 | 0,480 |

 **AISI 316**

Cerniera per tubo
capottineJoint for bimini
pipe

| Articolo - Item | €/pc. | Per tubo | |
|-----------------|-------|----------------|-------------|
| | | For pipe Ø mm. | Inner Ø mm. |
| O 24 20 108 | | 20x1,5 | 17 |

 **AISI 316**

Cappuccio con
occhio regolabileAdjustable eye
end cap

| Articolo - Item | €/pc. | Per tubo | |
|-----------------|-------|----------------|-------|
| | | For pipe Ø mm. | kg. |
| O 24 22 116 | | 22 | 0,170 |

 **AISI 316**



Snodo a forcella

Fork joint

| Articolo - Item | €/pc. | Per tubo | |
|-----------------|-------|----------------|-------|
| | | For pipe Ø mm. | kg. |
| O 24 22 100 | | 22 | 0,100 |
| O 24 25 100 | | 25 | 0,120 |

 **AISI 316**



Supporto a forcella

Fork support

| Articolo - Item | €/pc. | L mm. | Per tubo | |
|-----------------|-------|-------|----------------|-------|
| | | | For pipe Ø mm. | kg. |
| O 24 22 101 | | 70 | 22-25-30 | 0,170 |

 **AISI 316**



Supporto a forcella

Fork support

| Articolo - Item | €/pc. | L mm. | Per tubo | |
|-----------------|-------|-------|----------------|-----|
| | | | For pipe Ø mm. | kg. |
| O 24 22 102 | | 90x40 | 22-25-30 | |

 **AISI 316**



Coprigiunti

Joint cover

| Articolo - Item | €/pc. | €/Box | Ø mm. | kg. |
|-----------------|-------|-------|-------|-------|
| O 26 20 030 | | | 20 | 0,025 |



Snodo a forcella apribile

Openable fork joint

| Articolo - Item | €/pc. | Per tubo For pipe Ø mm. | kg. |
|-----------------|-------|-------------------------|-------|
| O 24 00 295 | | 22 | 0,130 |



AISI 316



Perno a molla

Spring pin

| Articolo - Item | €/pc. | €/Box |
|-----------------|-------|-------|
| O 24 32 025 | | |



Morsetto di riduzione Ø25 a Ø22 mm.

Clamp reduction Ø25 to Ø22 mm.

Acciaio inox Aisi 316 lucidato a specchio.

Mirror polished stainless steel Aisi 316.

| Articolo - Item | €/pc. | Per tubo For pipe Ø mm. | kg. |
|-----------------|-------|-------------------------|-------|
| O 24 30 025 | | 22-25 | 0,140 |



AISI 316



Coppia tenditori a nastro

Pair of belt tensioners

Provvista di agganci, fibbie e cavallotti.

With fittings and buckles.

| Articolo - Item | €/kit | Kit composto da Kit composed by | kg. |
|-----------------|-------|---------------------------------|-------|
| O 24 00 070 | | 2 Cinghie-Belts | 0,300 |



1kit made by



Coppia barre per utilizzare la capottina come roll-bar

Pair of bars suitable to convert the bimini top in a roll-bar

Fabbricate in acciaio inox Aisi 316.

Manufactured in Aisi 316 S.S.

| Articolo - Item | €/kit | Lunghezza mm. | Tubo-Pipe Ø mm. | kg. |
|-----------------|-------|---------------|-----------------|-------|
| O 26 22 900 | | 900 | 22 | 0,300 |



1kit made by **AISI 316**

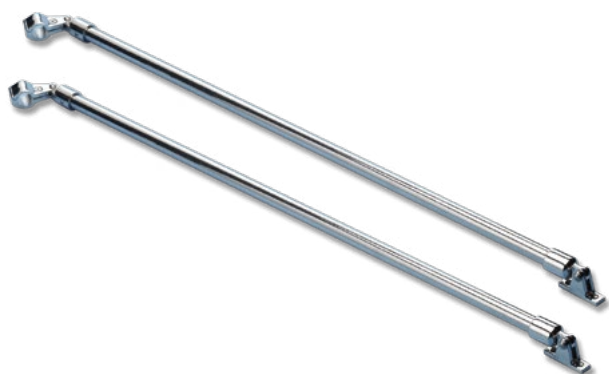

Tenditore telescopico

Telescopic tensioner

Fabbricato in acciaio inox, per capottine.

Manufactured in stainless steel, suitable for bimini tops. It allows to extend and stabilize the bimini top.

Composto da un tubo telescopico e due cappucci terminali uno dei quali girevole. Permette di tendere e rendere stabile la capottina sia nella posizione di utilizzo che a riposo.

| Articolo - Item | €/kit | Tubo-Pipe Ø mm. | Chiuso Closed mm. | Aperto Open mm. |
|-----------------|-------|-----------------|-------------------|-----------------|
| O 24 30 600 | | 25 | 600 | 800 |



1kit **AISI 316 NEW** made by

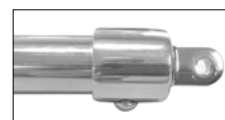
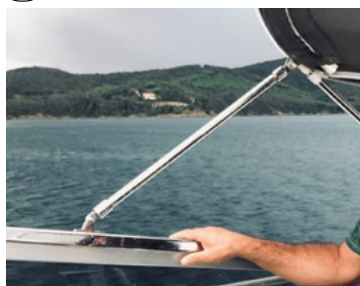

ACCESSORI TENDALINI | BIMINI TOP ACCESSORIES

Supporto per tubo Pipe support

Realizzato in nylon. In nylon.
Per corrimano Ø 25 mm. For rails Ø 25 mm.

| Articolo - Item | €/pc. | €/box | kg. |
|-----------------|-------|-------|-----|
| O 24 05 030 | | | |

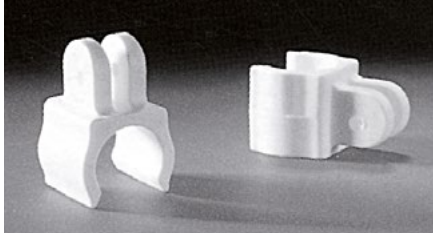

Attacco a scalmiera Fastening pin for rowlock

Realizzato in nylon. Manufactured in nylon.

| Articolo - Item | €/pc. | €/box | kg. |
|-----------------|-------|-------|-------|
| O 24 05 040 | | | 0,050 |

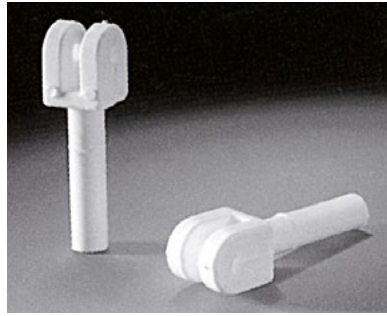

Boccola da incasso Fastening bushing

Realizzato in nylon. Manufactured in nylon.

| Articolo - Item | €/pc. | €/box | kg. |
|-----------------|-------|-------|-------|
| O 24 05 050 | | | 0,040 |

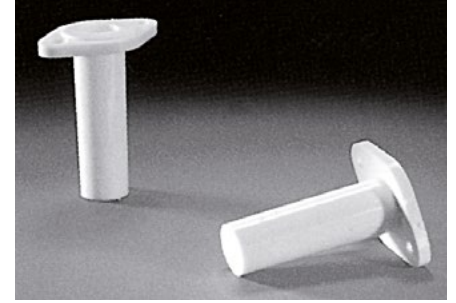

Attacco incollabile Suction discs

Realizzato in gomma. In rubber.

| Articolo - Item | €/pc. | €/box | kg. |
|-----------------|-------|-------|-------|
| O 24 05 025 | | | 0,310 |

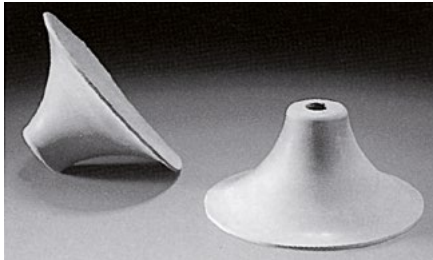

Kit «Sombrero»

Kit composto da:

- Cima
- 2 perni e 2 boccole

| Articolo - Item | €/kit | kg. |
|-----------------|-------|-------|
| O 24 45 011 | | 0,230 |



«Sombrero» kit

Kit with:

- Rope
- 2 pins + 2 bushings

Snodo Joint

| Articolo - Item | €/pc. | €/box | Ø mm. | kg. |
|-----------------|-------|-------|-------|-------|
| O 29 20 104 | | | 20 | 0,020 |



Tessuto sostitutivo per tendalini alluminio a 3 archi Replacement fabric for alu bimini tops 3 arches

| Articolo - Item | €/pc. | Per tendalino-For top Lunghezza-Length cm. | kg. |
|-----------------|-------|--|-------|
| O 28 00 170 | | 170 | 0,200 |
| O 28 00 185 | | 185 | 0,200 |
| O 28 00 200 | | 200 | 0,200 |
| O 28 00 225 | | 225 | 0,200 |



Busta contenitore per tendalino Bimini bag

| Articolo - Item | €/pc. | Per tendalino-For top Lunghezza-Length cm. | kg. |
|-----------------|-------|--|-------|
| O 22 03 150 | | 150 | 0,200 |
| O 22 03 170 | | 170 | 0,200 |
| O 22 03 185 | | 185 | 0,200 |
| O 22 03 200 | | 200 | 0,200 |
| O 22 03 225 | | 225 | 0,200 |





WATER RESISTANT FABRIC



IL TESSUTO 100% IMPERMEABILE

CARATTERISTICHE TECNICHE TECHNICAL FEATURES

- Tessuto Impermeabile
- Tessuto alluminizzato per dissipare il calore
- Fabbricato in 100% poliestere 200D o 300D o 600D a seconda della misura e dei modelli
- Dotato di elastico o cordino di fissaggio
- Doppie cuciture per garantire maggiore durata nel tempo
- Spessore poliestere 0,15mm
- Spalmatura in PA per garantire l'impermeabilità
- Eccezionale resistenza ai raggi UV.

- Waterproof fabric
- Anti-warmth aluminized fabric
- Made 100% in polyester 200D, 300D or 600D depending the model and sizes
- Equipped with fastening elastic or fastening lanyard
- Double sewing for longer life
- Polyester thickness 0,15 mm
- PA smeared
- UV resistant

CARATTERISTICHE TECNICHE TECHNICAL FEATURES

- Tessuto Impermeabile
- Tessuto floccato anti muffa
- Fabbricato in 100% poliestere
- Dotato di elastico o cordino di fissaggio
- Doppie cuciture rinforzate per garantire maggiore durata nel tempo
- Massima resistenza all'abrasione
- Eccezionale resistenza ai raggi UV
- Doppia spalmatura in PA per garantire l'impermeabilità
- Spessore poliestere maggiorato

- Waterproof fabric
- Anti-mildew flocked fabric
- Made 100% in polyester
- Equipped with fastening elastic or fastening lanyard
- Double sewing for longer life
- Max abrasion resistance
- UV high resistance
- Double PA smeared
- Double polyester thickness

VISIT OUR B2B AREA

CREATE A CUSTOMER ACCOUNT
CHECK AVAILABILITY & QUANTITY OF ITEMS
CHECK YOUR COMMERCIAL CONDITION
PLACE YOUR ORDER
TRACK YOUR ORDER STATUS
TRACK YOUR PAYMENT PROCESS



WWW.TREM.NET



TROVA IL TELO GIUSTO PER LA TUA BARCA O GOMMONE FIND THE RIGHT COVER FOR YOUR BOAT

Vi segnaliamo che i teli sono misurati e realizzati in piano ecco perche se sulla vostra barca/ gommone vi sono eventuali altezze **H** di consolle e/o T-Top devono essere sommate alle misure lunghezza **X**, larghezza **Y**.

La misurazione dell'altezza **H** deve avvenire dal vertice murata della barca (non dal calpestio) all'altezza massima della consolle/T-Top. Normalmente i gommoni hanno necessita di teli sempre qualche taglia piu grandi, in quanto il telo sul gommone per arrivare al punto di fissaggio che è il bottazzo ,deve superare i centimetri di tubolare (normalmente vengono considerati circa 25 cm **G** per lato di maggiorazione alle quote **X-Y**).

Ecco perche vi suggeriamo di seguire gli schemi e l'esempio sotto indicato per il calcolo delle misure.

ESEMPIO IMBARCAZIONE: ipotizziamo la vostra barca abbia una lunghezza **X** fuoritutta di 600cm. e una larghezza **Y** nel punto massimo di 300 cm., ipotizziamo che la vs consolle **H** sporga di 80 cm da sponda a punto massimo.

il calcolo sara il seguente : **X+H= 680, Y+H=380**

IL TELO PER VOI COME SI EVINCE DA DISEGNI E TABELLE A PAG.345 E' **XXL**

ESEMPIO GOMMONE: ipotizziamo IL vs. gommone abbia una lunghezza **X** fuoritutta di 650cm. e una larghezza **Y** nel punto massimo di 270 cm., ipotizziamo che la vs consolle **H** sporga di 40 cm da sponda a punto massimo.

il calcolo sara il seguente : **X+H+(Gx2)= 740, Y+H+(Gx2)=360**

IL TELO PER VOI COME SI EVINCE DA DISEGNI E TABELLE A PAG.345 E' **MAXI**

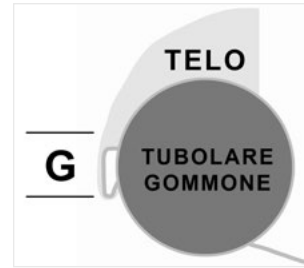
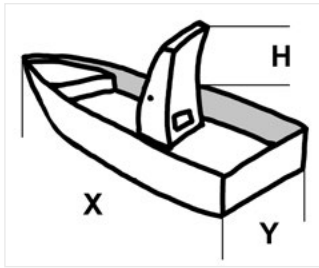

TROVA IL TELO GIUSTO PER IL TUO MOTORE FIND THE RIGHT COVER FOR YOUR ENGINE

1

Misurare circonferenza e altezza del vostro motore.
Measure your engine's circumference and height.

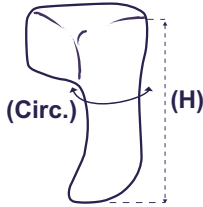

2

Verificata la misura del vostro motore, abbinatela alla calza più idonea. Once the size of your engine has been verified, combine it with the most suitable cover.

| Taglia Size | HP | Circonferenza Circumference cm. | H cm. |
|----------------|---------|------------------------------------|-------|
| S | 5-10 | 140 | 125 |
| M | 10-30 | 160 | 150 |
| L | 30-60 | 180 | 145 |
| XL | 40-100 | 200 | 170 |
| XXL | 70-175 | 225 | 190 |
| MAXI | 135-300 | 260 | 210 |

Abbinamenti dei motori idonei ai nostri teli

| Articolo - Item COVY LINE | Articolo - Item COVY LUX | HP | Taglia Size | SUZUKI 4 STROKE (Shaft length) | YAMAHA 4 STROKE (Shaft length) | MERCURY 4 STROKE (Shaft length) | EVINRUDE E-TEC (Shaft length) | HONDA 4 STROKE (Shaft length) |
|------------------------------|-----------------------------|---------|----------------|---|---|---|--|--|
| O 22 25 075 | O 42 25 075 | 5-10 | S | DF8 (15/20 in) DF9.9 (15/20 in) DF15A, DF20A (15/20 in) | F8, F9.9 (15/20 in) T9.9 HIGH THRUST (20 in) | 5 (25 in) 8, 9.9 (15/20 in) 9.9 Pro Kicker (20 in) 9.9 Big Foot (20 in) | 8 (15/20 in) 9.8 (15/20 in) | BF8 (15/20 in) BF9.9 (15/20 in) |
| O 22 15 087 | O 42 15 087 | 10-30 | M | DF25A (15/20 in) DF30A (20 in) | F9.9 HIGH THRUST (25 in) F15 (15/20 in) F20 (15/20 in) | 9.9 (25 in) 15, 20 (15/20 in) 9.9 Pro Kicker (25 in) 15 Pro Kicker (20 in) 9.9 Big Foot (25 in) | 9.8 (25 in) 15 (15/20 in) 25 (15/20 in) 30 (15/20 in) | BF9.9 (25 in) BF15 (25 in) BF20 (25 in) |
| O 22 18 145 | O 42 18 145 | 30-60 | L | DF40A (20 in) DF50A (20 in) DF60A (20 in) | F25 (15/20 in) T25 HIGH THRUST (20 in) | 15 Pro Kicker (25 in) 25, 30 EFI (15/20 in) 25 EFI JET (15/20 in) | 40 (20 in) 50 (20 in) 60 (20 in) | BF25 (15/20 in) BF30 (15/20 in) |
| O 22 21 170 | O 42 21 170 | 40-100 | XL | DF60A (25 in) DF60AV (20/25 in) DF70A (20 in) DF90A (20 in) | F30, F40, F50 (20 in) F60, F70, F75 (20 in) F80, F90 (20 in) T50, T60 HIGH THRUST (20 in) F60 JET DRIVE (25 in) F100D (20 in) | 40 EFI (15/20 in) 60 EFI (20 in) 40 EFI CT (20 in) 50 EFI CT (20 in) 60 EFI CT (20 in) 40 EFI JET (15/20 in) | 75 (25 in) 90 (20 in) | BF40 (20 in) BF50 (20 in) BF60 (20 in) BF75 (20 in) BF90 (20 in) |
| O 22 22 290 | O 42 22 290 | 70-175 | XXL | DF70A (25 in) DF90A (25 in) DF115A (20/25 in) DF140A (20/25 in) DF100 (20/25 in) DF150 (20/25 in) DF175 (20/25 in) | F80 (25 in) F90 (25 in) F100D (25 in) F115 (20/25 in) F150 (20/25 in) F90 JET DRIVE (25 in) F115 JET DRIVE (25 in) F150 JET DRIVE (25 in) VF115 VMAX SHO (20 in) | 60 EFI CT (25 in) 90, 115 EFI CT (20/25 in) 75 EFI (20 in) 90, 100, 115, 150 EFI (20/25 in) 80 EFI JET (20 in) 75 OPTIMAX (20 in) 90, 115, 125 OPTIMAX (20/25 in) 115 OPTIMAX PRO XS (20/25 in) | 75, 90 (25 in) 115 (20/25 in) 130 (20/25 in) 150 (20/25 in) 90 H.O. (20/25 in) 115 H.O. (20/25 in) 135 H.O. (20/25 in) 150 H.O. (20/25 in) 175 (20/25 in) | BF50 (25 in) BF60 (25 in) BF90 (25 in) BF115 (20/25 in) BF135 (20/25 in) BF150 (20/25 in) |
| O 22 21 125 | O 42 21 125 | 135-300 | MAXI | DF200 (25 in) DF225 (25 in) DF250 (25 in) DF200A (25 in) DF250AP (25 in) DF300AP (25 in) DF250AP (30 in) DF300AP (30 in) DF225 (30 in) DF250 (30 in) | F175 (20/25 in) F200 (20/25 in) VF150, VF175 VMAX SHO (20/25 in) F200 V6 (25 in) F225 V6 (25 in) F250 V6 (25 in) F225, F250, F300 OFF-SHORE (25 in) VF200, VF225 VMAX SHO (20 in) VF250 VMAX SHO (20/25 in) F250 OFFSHORE (30 in) F300 OFFSHORE (30 in) | 135, 150, 175, 200 VERADERO (20/25 in) 200, 250 OPTIMAX (25 in) 225 OPTIMAX (20/25 in) 150, 175, 200, 225, 250 OPTIMAX PRO XS (20/25 in) 225, 300, 350 VERADERO (20/25 in) 250 VERADERO (25 in) 200, 250, 300 VERADERO PRO (20/25 in) 250 OPTIMAX (30 in) 225, 250, 300, 350 VERADERO (30 in) | 200, 225 (20/25 in) 200 H.O. (20/25 in) 225 H.O. (20/25 in) 250 (25 in) 225 H.O. (20/25 in) 300 (20/25 in) E-TEC G2 200-300 hp (20/25 in) 300 (30 in) 250 (30 in) E-TEC G2 200-300 hp (30 in) | BF200 (20/25 in) BF225 (20/25 in) BF250 (20/25 in) BF225 (30 in) BF250 (30 in) |



WATER RESISTANT FABRIC

Teli copri motore «Covy Line»

Tessuto poliestere 210D. Oxford.
Spessore tessuto 0,15 mm.
Peso materiale 105 gr./mt².
PU spalmato argento.
Water pressure 1200 W/P.

Full engine covers «Covy Line»

Polyester fabric 210D. Oxford.
Fabric thickness 0,15 mm.
Thickness 105 gr./mt².
PU silver coating.
Water pressure 1200 W/P

| Articolo - Item | €/pc. | Taglia Size | HP | Circonferenza Circumference cm. | H cm. | pz.-pcs. | kg. |
|-----------------|-------|-------------|---------|---------------------------------|-------|----------|-------|
| O 22 25 075 | | S | 5-10 | 140 | 125 | 1 | 0,200 |
| O 22 15 087 | | M | 10-30 | 160 | 150 | 1 | 0,280 |
| O 22 18 145 | | L | 30-60 | 180 | 145 | 1 | |
| O 22 21 170 | | XL | 40-100 | 200 | 170 | 1 | |
| O 22 22 190 | | XXL | 70-175 | 225 | 190 | 1 | |
| O 22 21 125 | | MAXI | 135-300 | 250 | 210 | 1 | 0,490 |

WATERPROOF made by



COVY LUX

IL TESSUTO 100% IMPERMEABILE

Teli copri motore «Covy Lux»

Tessuto poliestere 600D. Oxford.
Spessore tessuto 1,05 mm.
Peso materiale 360 gr./mt².
Spalmatura floccata.
Water pressure 900 W/P.

Full engine covers «Covy Lux»

Polyester fabric 600D. Oxford.
Fabric thickness 1,05 mm.
Thickness 360 gr./mt².
Flocking coating.
Water pressure 900 W/P

| Articolo - Item | €/pc. | Taglia Size | HP | Circonferenza Circumference cm. | H cm. | pz.-pcs. | kg. |
|-----------------|-------|-------------|---------|---------------------------------|-------|----------|-------|
| O 42 25 075 | | S | 5-10 | 140 | 125 | 1 | 0,900 |
| O 42 15 087 | | M | 10-30 | 160 | 150 | 1 | 1,000 |
| O 42 18 145 | | L | 30-60 | 180 | 145 | 1 | |
| O 42 21 170 | | XL | 40-100 | 200 | 170 | 1 | |
| O 42 22 190 | | XXL | 70-175 | 225 | 190 | 1 | |
| O 42 21 125 | | MAXI | 135-300 | 260 | 210 | 1 | 1,100 |

WATERPROOF made by

TELO 100% IMPERMEABILE E FLOCCATO PER ELIMINARE L'UMIDITÀ
100% WATERPROOF COVER TO PREVENT MOISTURE





WATER RESISTANT FABRIC

Teli copri testa motore «Covy Line»

Tessuto poliestere 210D. Oxford.
Spessore tessuto 0,15 mm.
Peso materiale 20 gr./mt².
PU spalmato argento.
Water pressure 1200 W/P.

Engine covers «Covy Line»

Polyester fabric 210D. Oxford.
Fabric thickness 0,15 mm.
Thickness 120 gr./mt².
PU silver coating.
Water pressure 1200 W/P.

| Articolo - Item | €/pc. | Taglia Size | HP | L cm. | W cm. | H cm. | pz.-pcs. | kg. |
|------------------------|-------|-------------|---------|-------|-------|-------|----------|-------|
| O 22 25 040 NEW | | XXS | 0-5 | 40 | 25 | 30 | 1 | 0,100 |
| O 22 27 048 | | XS | 2-15 | 48 | 27 | 33 | 1 | 0,120 |
| O 22 33 055 | | S | 10-45 | 55 | 33 | 42 | 1 | 0,160 |
| O 22 35 063 | | M | 30-90 | 63 | 35 | 48 | 1 | 0,190 |
| O 22 40 073 | | L | 70-150 | 73 | 40 | 65 | 1 | 0,250 |
| O 22 45 075 | | XL | 115-225 | 75 | 45 | 75 | 1 | 0,300 |
| O 22 60 090 | | XXL | 150-300 | 90 | 60 | 80 | 1 | 0,400 |

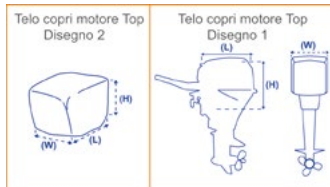

TELI E CAPOTTINE | BIMINI TOPS & BOAT COVERS

COVY LUX

IL TESSUTO 100% IMPERMEABILE

Teli copri testa motore «Covy Lux»

Tessuto poliestere 600D. Oxford.
Spessore tessuto 1,05 mm.
Peso materiale 360 gr./mt².
Spalmatura floccata.
Water pressure 900 W/P.

Engine covers «Covy Lux»

Polyester fabric 600D. Oxford.
Fabric thickness 1,05 mm.
Thickness 360 gr./mt².
Flocking coating.
Water pressure 900 W/P.

| Articolo - Item | €/pc. | Taglia Size | HP | L cm. | W cm. | H cm. | pz.-pcs. | kg. |
|------------------------|-------|-------------|---------|-------|-------|-------|----------|-------|
| O 42 25 040 NEW | | XXS | 0-5 | 40 | 25 | 30 | 1 | |
| O 42 27 048 | | XS | 2-15 | 48 | 27 | 33 | 1 | 0,330 |
| O 42 33 055 | | S | 10-45 | 55 | 33 | 42 | 1 | 0,440 |
| O 42 35 063 | | M | 30-90 | 63 | 35 | 48 | 1 | 0,540 |
| O 42 40 073 | | L | 70-150 | 73 | 40 | 65 | 1 | 0,750 |
| O 42 45 075 | | XL | 115-225 | 75 | 45 | 75 | 1 | 1,000 |
| O 42 60 090 | | XXL | 150-300 | 90 | 60 | 80 | 1 | 1,260 |



**TELO 100% IMPERMEABILE E FLOCCATO PER ELIMINARE L'UMIDITÀ
100% WATERPROOF COVER TO PREVENT MOISTURE**

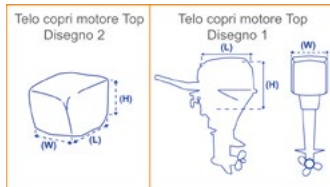



WATER RESISTANT FABRIC

Teli copri barca «Covy Line»

Tessuto poliestere 210D. Oxford. Spessore tessuto 0,15 mm.
Peso materiale 120 gr./m². PU spalmato argento.
Water pressure 1200 W/P.

Boat covers «Covy Line»

Polyester fabric 210D. Oxford. Fabric thickness 0,15 mm.
Thickness 120 gr./m². PU silver coating.
Water pressure 1200 W/P.

| Articolo - Item | €/pc. | Taglia Size | Lungh. barca For boats L cm. | Lungh. gommone Rubber width max cm. | Largh. barca/gommone Boat width max cm. | N. Cinghie Belts | Colore Colour | pcs. | kg. |
|------------------------|-------|-------------|------------------------------|-------------------------------------|---|------------------|----------------|------|-------|
| O 22 16 240 NEW | | MINI TENDER | - | 160-240 | 135-155 | 6 | Argento-Silver | 1 | |
| O 22 24 300 | | TENDER | - | 240-300 | 135-155 | 6 | Argento-Silver | 1 | 1,600 |
| O 22 30 360 | | MAXI TENDER | - | 300-360 | 135-155 | 7 | Argento-Silver | 1 | 1,950 |
| O 22 21 360 NEW | | MAXI TENDER | - | 300-360 | 200-220 | 7 | Argento-Silver | 1 | |
| O 22 18 488 | | XXS | 427-488 | - | 170-190 | 8 | Argento-Silver | 1 | 1,750 |
| O 22 22 488 | | XS | 427-488 | 360-440 | 210-230 | 10 | Argento-Silver | 1 | 2,400 |
| O 22 23 488 | | S | 488-564 | 440-490 | 220-240 | 10 | Argento-Silver | 1 | 2,520 |
| O 22 24 579 | | M | 518-579 | 490-520 | 225-250 | 10 | Argento-Silver | 1 | 2,900 |
| O 22 26 610 | | L | 550-610 | 520-550 | 240-270 | 10 | Argento-Silver | 1 | 3,050 |
| O 22 29 650 | | XL | 580-650 | 550-590 | 270-300 | 10 | Argento-Silver | 1 | 3,300 |
| O 22 38 710 | | XXL | 630-710 | 590-640 | 320-370 | 13 | Argento-Silver | 1 | 4,900 |
| O 22 70 780 | | MAXI | 700-780 | 640-700 | 330-380 | 14 | Argento-Silver | 1 | 5,300 |
| O 22 36 300 | | AQUAJET | 300-360 | - | 150 | 7 | Argento-Silver | 1 | |
| O 22 22 360 NEW | | AQUAJET | 300-360 | - | 220 | 7 | Argento-Silver | 1 | |

WATERPROOF made by

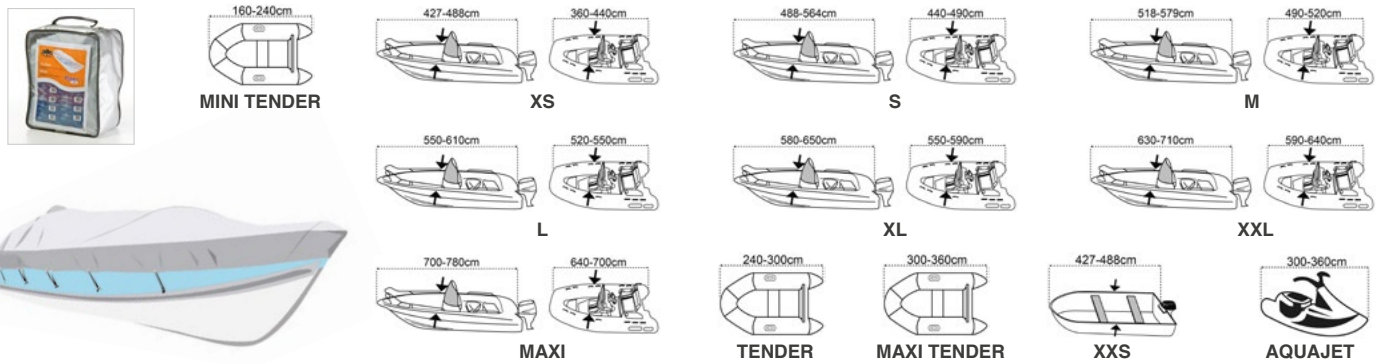

COVY LUX

IL TESSUTO 100% IMPERMEABILE

Teli copri barca «Covy Lux»

Tessuto poliestere 600D. Oxford
Spessore tessuto 1,05 mm.
Peso materiale 360 gr./m².
Spalmatura floccata.
Water pressure 900 W/P.

Boat covers «Covy Lux»

Polyester fabric 600D. Oxford
Fabric thickness 1,05 mm.
Thickness 360 gr./m².
Flocking coating.
Water pressure 900 W/P.

| Articolo - Item | €/pc. | Taglia Size | Lungh. barca For boats L cm. | Lungh. gommone For rubber L cm. | Largh. barca/gommone Boat width max cm. | N. Cinghie Belts | Colore Colour | pcs. | kg. |
|-----------------|-------|-------------|------------------------------|---------------------------------|---|------------------|---------------|------|-----|
| O 42 24 300 | | TENDER | - | 240-300 | 135-155 | 6 | Grigio-Grey | 1 | |
| O 42 30 360 | | MAXI TENDER | - | 300-360 | 135-155 | 6 | Grigio-Grey | 1 | |
| O 42 22 488 | | XS | 427-488 | 360-440 | 210-230 | 8 | Grigio-Grey | 1 | |
| O 42 23 488 | | S | 488-564 | 488-564 | 220-240 | 10 | Grigio-Grey | 1 | |
| O 42 24 579 | | M | 518-579 | 490-520 | 225-250 | 10 | Grigio-Grey | 1 | |
| O 42 26 610 | | L | 550-610 | 520-550 | 240-270 | 10 | Grigio-Grey | 1 | |
| O 42 29 650 | | XL | 580-650 | 550-590 | 270-300 | 10 | Grigio-Grey | 1 | |
| O 42 38 710 | | XXL | 630-710 | 590-640 | 320-370 | 10 | Grigio-Grey | 1 | |
| O 42 70 780 | | MAXI | 700-780 | 640-700 | 330-380 | 10 | Grigio-Grey | 1 | |
| O 42 36 300 | | AQUAJET | 300-360 | - | 150 | 6 | Grigio-Grey | 1 | |

WATERPROOF made by

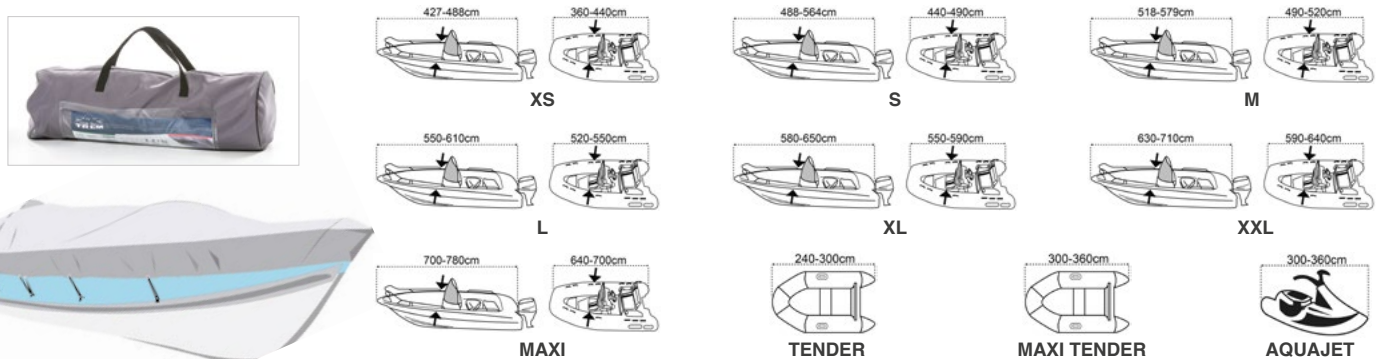



WATER RESISTANT FABRIC

Teli copri consolle «Covy Line»

Tessuto poliestere 210D. Oxford
Spessore tessuto 0,15 mm.
Peso materiale 120 gr./mt².
PU spalmato argento.
Water pressure 1200 W/P

Console covers «Covy Line»

Polyester fabric 210D. Oxford
Fabric thickness 0,15 mm.
Thickness 120 gr./mt².
PU silver coating.
Water pressure 1200. W/P

| Articolo - Item | €/pc. | Taglia Size | A cm. | B cm. | C cm. | D cm. | pz.-pcs. | kg. |
|-----------------|-------|-------------|-------|-------|-------|-------|----------|-------|
| O 22 55 115 | | XS | 115 | 90 | 45 | 55 | 1 | 0,250 |
| O 22 85 090 | | S | 90 | 65 | 75 | 85 | 1 | 0,350 |
| O 22 65 120 | | M | 120 | 105 | 70 | 65 | 1 | 0,450 |
| O 22 70 140 | | L | 140 | 100 | 90 | 70 | 1 | 0,580 |
| O 22 90 140 | | XL | 140 | 100 | 90 | 90 | 1 | 0,650 |
| O 22 99 140 | | XXL | 140 | 100 | 110 | 110 | 1 | - |

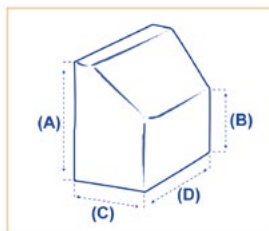
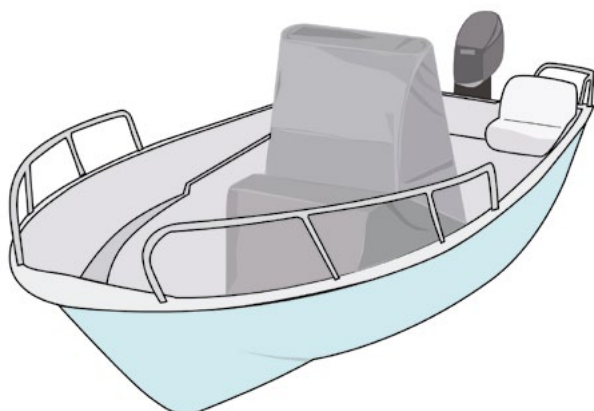

COVY LUX

IL TESSUTO 100% IMPERMEABILE

Teli copri consolle «Covy Lux»

Tessuto poliestere 600D. Oxford
Spessore tessuto 1,05 mm.
Peso materiale 360 gr./mt².
Spalmatura floccata.
Water pressure 900 W/P

Console covers «Covy Lux»

Polyester fabric 600D. Oxford
Fabric thickness 1,05 mm.
Thickness 360 gr./mt².
Flocking coating.
Water pressure 900. W/P

| Articolo - Item | €/pc. | Taglia Size | A cm. | B cm. | C cm. | D cm. | pz.-pcs. | kg. |
|-----------------|-------|-------------|-------|-------|-------|-------|----------|-------|
| O 42 85 090 | | S | 90 | 65 | 75 | 85 | 1 | 0,350 |
| O 42 65 120 | | M | 120 | 105 | 70 | 65 | 1 | 0,450 |
| O 42 70 140 | | L | 140 | 100 | 90 | 70 | 1 | 0,580 |
| O 42 90 140 | | XL | 140 | 100 | 90 | 90 | 1 | 0,650 |
| O 42 99 140 | | XXL | 140 | 100 | 110 | 110 | 1 | - |



TELO 100% IMPERMEABILE E FLOCCATO PER ELIMINARE L'UMIDITÀ
100% WATERPROOF COVER TO PREVENT MOISTURE

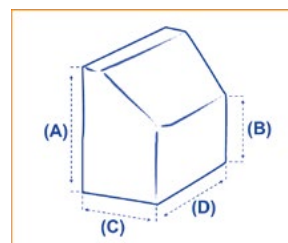
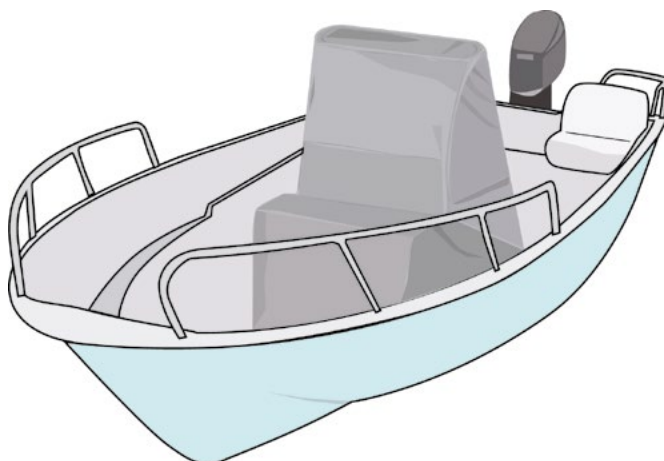

COVY LUX

IL TESSUTO 100% IMPERMEABILE

Calza copri winch «Covy Line»

Tessuto poliestere 600D. Oxford
Spessore tessuto 1,05 mm.
Peso materiale 360 gr./mt².
Spalmatura floccata.
Water pressure 900 W/P

Winch covers «Covy Line»

Polyester fabric 600D. Oxford
Fabric thickness 1,05 mm.
Thickness 360 gr./mt².
Flocking coating.
Water pressure 900. W/P

| Articolo - Item | €/pc. | Mod. | H mm. | Ø mm. | pz.-pcs. | kg. |
|-----------------|-------|--------------|-------|-------|----------|-------|
| O 42 13 130 | | Standard | 130 | 130 | 1 | 0,350 |
| O 42 14 145 | | Standard | 145 | 140 | 1 | 0,450 |
| O 42 14 160 | | Self-tailing | 160 | 145 | 1 | 0,580 |
| O 42 15 180 | | Self-tailing | 180 | 150 | 1 | 0,650 |
| O 42 20 170 | | Self-tailing | 200 | 170 | 1 | |
| O 42 19 215 | | Self-tailing | 215 | 190 | 1 | |
| O 42 20 230 | | Self-tailing | 230 | 200 | 1 | |
| O 42 20 250 | | Self-tailing | 250 | 205 | 1 | |
| O 42 27 280 | | Self-tailing | 280 | 270 | 1 | |
| O 42 29 315 | | Self-tailing | 315 | 290 | 1 | |

100% IMPERMEABILE-WATERPROOF made by 



SACCA PORTA MOTORE AUSILIARIO | AUXILIARY OUTBOARD ENGINE CARRY BAG

Sacca porta motore ausiliario

Realizzata in Poliestere 600D Oxford.
Imbottita e spalmata.
Con cinghie in poliestere.
Ideale per motori ausiliari.

Auxiliary outboard engine carry bag

Manufactured in Polyester 600D Oxford.
Padded and coated surface.
Supplied with polyester belts.
Suitable for auxiliary outboard motors.

| Articolo - Item | €/pc. | Ideale per motori For marine engines | A cm. | B cm. | C cm. | D cm. | E cm. | Portata-Load kg. | kg. |
|-----------------|-------|---|-------|-------|-------|-------|-------|---------------------|-----|
| O 22 00 105 | | < 2,5 HP | 105 | 46 | 11 | 23 | 33 | 35 | |
| O 22 00 121 | | > 2,5-5 < HP | 121 | 50 | 13 | 30 | 40 | 45 | |

 WATERPROOF made by  **NEW**

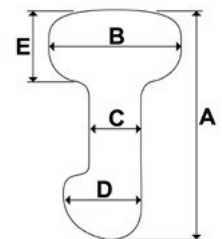



WATER RESISTANT FABRIC

Calza copri elica impermeabile

Ideale per la protezione dell'elica del motore fuoribordo durante il trasporto. Colore arancio fluo.

Waterproof propeller cover

For whole protection of the propeller of outboard engines when carrying. Fluorescent orange colour.

| Articolo - Item | €/pc. | cm. | kg. |
|-----------------|-------|-------|-------|
| O 22 25 070 | | 54x50 | 0,080 |
| O 22 40 040 | | 40x40 | |
| O 22 67 065 | | 67x65 | |



SUGGESTED ITEM

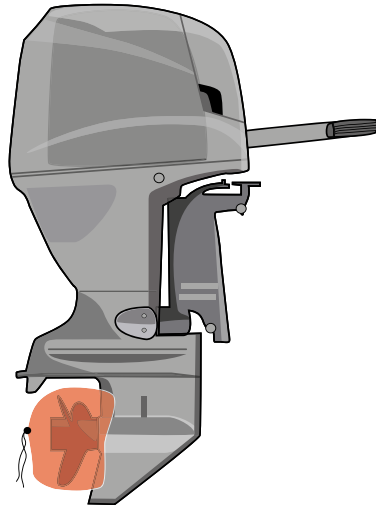

TELE E CAPOTTINE | BIMINI TOPS & BOAT COVERS

COPRI PIEDE IMPERMEABILE | WATERPROOF ENGINE COVERS

Copripiede impermeabile

Copertura per la protezione del piede del motore fuoribordo o gruppo poppiere dalla vegetazione marina e dalle correnti galvaniche. Il copripiede può inoltre svolgere la funzione di contenitore per il risciacquo con acqua dolce del circuito di raffreddamento, senza necessità di allare la barca. Operazioni di montaggio e smontaggio rapide. Il robusto tessuto con doppia spalmatura in PVC garantisce la lunga durata del prodotto.

Waterproof engine cover

Waterproof thermo-welded engine cover made of special PVC designed to avoid any making of sea vegetation on the surface of outboard engines. This cover may be also used as a can for washing of the cooling circuit by mean of fresh water. Easy mounting and dismantling operation in a few minutes. Strong fabric provided with double PVC coating to ensure a longer life of the cover.

| Articolo - Item | €/pc. | Per motori-For marine engines | cm. | kg. |
|-----------------|-------|-------------------------------|---------|-------|
| O 22 00 100 | | fino a - up to 100HP | H120x68 | 0,910 |
| O 22 00 101 | | oltre - over 100HP | H135x86 | 1,370 |





WATER RESISTANT FABRIC

Teloni in raffia

Fabbricato in PE.
Rinforzo con corda in PP interna.
Occhioli in alluminio ogni 100 cm.

Covers in raffia

Made in PE.
Support with internal rope in PP.
Aluminium eyes every 100cm.

| Articolo - Item | €/pc. | €/mq | 📦 gr/mq | ↑ mt. | Colore esterno Outer colour | Colore interno Inner colour | 📦 kg. |
|-----------------|-------|------|---------|-------|--------------------------------|--------------------------------|-------|
| O 41 13 023 | | | 0,130 | 2x3 | Verde-Green | Bianco-White | 0.78 |
| O 41 13 033 | | | 0,130 | 3x3 | Verde-Green | Bianco-White | 1.17 |
| O 41 13 034 | | | 0,130 | 3x4 | Verde-Green | Bianco-White | 1.56 |
| O 41 13 036 | | | 0,130 | 3x6 | Verde-Green | Bianco-White | 2.34 |
| O 41 13 044 | | | 0,130 | 4x4 | Verde-Green | Bianco-White | 2.08 |
| O 41 13 045 | | | 0,130 | 4x5 | Verde-Green | Bianco-White | 2.60 |
| O 41 13 048 | | | 0,130 | 4x8 | Verde-Green | Bianco-White | 4.16 |
| O 41 13 057 | | | 0,130 | 5x7 | Verde-Green | Bianco-White | 4.55 |
| O 41 13 068 | | | 0,130 | 6x8 | Verde-Green | Bianco-White | 6.24 |
| O 40 13 023 | | | 0,130 | 2x3 | Azzurro-Light blue | Bianco-White | 0.78 |
| O 40 13 033 | | | 0,130 | 3x3 | Azzurro-Light blue | Bianco-White | 1.17 |
| O 40 13 034 | | | 0,130 | 3x4 | Azzurro-Light blue | Bianco-White | 1.56 |
| O 40 13 036 | | | 0,130 | 3x6 | Azzurro-Light blue | Bianco-White | 2.34 |
| O 40 13 044 | | | 0,130 | 4x4 | Azzurro-Light blue | Bianco-White | 2.08 |
| O 40 13 045 | | | 0,130 | 4x5 | Azzurro-Light blue | Bianco-White | 2.60 |
| O 40 13 048 | | | 0,130 | 4x8 | Azzurro-Light blue | Bianco-White | 4.16 |
| O 40 13 057 | | | 0,130 | 5x7 | Azzurro-Light blue | Bianco-White | 4.55 |
| O 40 13 068 | | | 0,130 | 6x8 | Azzurro-Light blue | Bianco-White | 6.24 |
| O 40 20 037 | | | 0,200 | 3x7 | Blu-Blue | Nero-Black | 4.20 |
| O 40 20 045 | | | 0,200 | 4x5 | Blu-Blue | Nero-Black | 4.00 |
| O 40 20 048 | | | 0,200 | 4x8 | Blu-Blue | Nero-Black | 6.40 |
| O 40 20 049 | | | 0,200 | 4x9 | Blu-Blue | Nero-Black | 7.20 |
| O 40 20 057 | | | 0,200 | 5x7 | Blu-Blue | Nero-Black | 7.00 |
| O 40 20 068 | | | 0,200 | 6x8 | Blu-Blue | Nero-Black | 9.60 |
| O 40 20 106 | | | 0,200 | 10x6 | Blu-Blue | Nero-Black | 12.00 |
| O 40 20 128 | | | 0,200 | 12x8 | Blu-Blue | Nero-Black | 19.20 |



0,130 gr/mq



0,130 gr/mq



0,200 gr/mq

ACCESSORI PER TELI COPRI BARCA | ACCESSORIES FOR BOAT COVERS

Occhioli e rondelle da ribadire Eyelets and washers to be placed

Provvisi di relativi attrezzi per il montaggio su tende campeggio, vele, imbarcazioni, indumenti etc.

Equipped with their tools for mounting on camping tents, sails, boats, clothes etc.

| Articolo - Item | €/ 15 set | Ø mm. | Box kg. |
|-----------------|-----------|-------|---------|
| E 05 41 370 | | 11 | 0,145 |



Bottoni a ribadire nichelati Riveting buttons, nickel plated

Indicati per tende, verande, coperture etc. Provvisi di relativo attrezzo per il montaggio.

Suitable for curtains, porches, roofing. Equipped with their tools for mounting.

| Articolo - Item | €/ 10 set | Ø mm. | Box kg. |
|-----------------|-----------|-------|---------|
| E 03 90 301 | | 15 | 0,120 |



Bottoni a ribadire con vite Riveting buttons with screw

Indicati per applicazione tessuto o teloni a superfici solide quali roulotte, imbarcazioni etc. Provvisi di relativo attrezzo per il montaggio.

Suitable for applying fabric or tarps to hard surfaces as caravans, boats, etc. Equipped with their tools for mounting

| Articolo - Item | €/ 10 set | Ø mm. | Box kg. |
|-----------------|-----------|-------|---------|
| E 03 90 211 | | 15 | 0,135 |



Tornichetti girevoli inossidabili Turnbuckles stainless swivel

L'occhiello si fissa a pressione nella parte in tela. Indicati per tendalini e imbarcazioni in quanto inossidabili.

The eyelet is fixed by pressure on the canopy Suitable for canopies and boats as they are stainless.

| Articolo - Item | €/ 4 set | Mod. | Box kg. |
|-----------------|----------|----------------------|---------|
| E 05 00 150 | | A pressione-Pressure | 0,150 |



Bottoni in ottone cromato Chromium plated brass buttons

A pressione.

Pressure.

| Articolo - Item | €/ 10 | Tipo-Type | kg. |
|-----------------|-------|------------------------------|--------------|
| N 58 01 034 | | A vite autofilettante-Screw | Male 0,010 |
| N 58 02 034 | | A vite e dado-Screw & nut | Male 0,010 |
| N 58 04 034 | | Aggraffatura a tessuto-Crimp | Male 0,010 |
| N 58 06 034 | | Ad avvitamento-Screw thread | Female 0,010 |
| N 58 05 000 | | Chiave montaggio-Key | - 0,010 |

Bottoni in acciaio inox Stainless steel press buttons

| Articolo - Item | €/ 10 | kg. |
|-----------------|-------|--|
| N 58 10 004 | | Maschio c/vite p/paratia-Male w/bulkhead screw int. mm ø10 - est. mm ø17 |
| N 58 17 007 | | Borchia esterna Ø mm. 17 con femmina External stud ø mm.17 with female |
| N 58 14 007 | | Borchia esterna Ø mm. 14 con femmina External stud ø mm. 14 with female |



BLISTER 10 series



Bottoni in acciaio inox Stainless steel press buttons

| Articolo - Item | €/pc. | €/ Box da 200 pc. | kg. |
|-----------------|-------|-------------------|-----------------------------|
| N 58 01 004 | | | Maschio-Male |
| N 58 02 045 | | | Borchia-Stud |
| N 58 03 035 | | | Borchia femmina-Stud female |
| N 58 17 004 | | | Borchia-Stud ø 17 mm. |
| N 58 14 005 | | | Borchia-Stud ø 14 mm. |



Tornichetti

Fabbricati in lega di alluminio anodizzato e in nylon antiurto.

Turn buttons

Made of anodized light alloy aluminium, with self-threading screws of stainless steel.

| Articolo - Item | €/pc. | €/Box | Ø mm. | Materiale Material |
|-----------------|-------|-------|-------|--------------------|
| N 58 12 025 | | | 12 | Alluminio-Alu |



Tenditore in EPDM

EPDM stretcher

| Articolo - Item | €/pc. | €/Box | Lunghezza Length mm. | Colore Colour | Durezza Hardness SH | kg. |
|-----------------|-------|-------|----------------------|---------------|---------------------|-------|
| Z 15 74 190 | | | 190 | White | 50 | 0,450 |



Ventosa con elastico per fissaggio teli copribarche

Permettono di trattenere il telo copribarca sullo scafo.

Suction cup with elastic band for boat covers

Suitable to fasten the boat covering clothes.

| Articolo - Item | €/pc. | €/Box | Lunghezza elastico Stretcher length mm. | Ventosa-Suction cup Ø mm. |
|-----------------|-------|-------|---|---------------------------|
| O 11 20 000 | | | 200 | 90 |

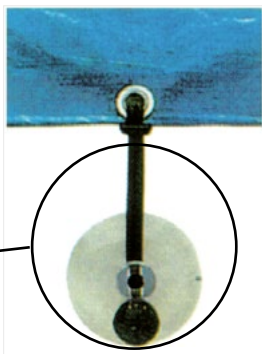

Pali telescopici displuvio

Fabbricati in tubo di alluminio anodizzato, bloccaggio rotazionale. Tubo Ø 25 - 30 mm.

Telescopic awning support pole

Made of anodised aluminium. To prevent water stagnation in the awning. Pipe Ø 25 - 30 mm.

| Articolo - Item | €/pc. | Estensione-Range cm. | kg. |
|-----------------|-------|----------------------|-------|
| R 00 30 100 | | 60-100 | 1,300 |
| R 00 30 150 | | 90-150 | 1,500 |

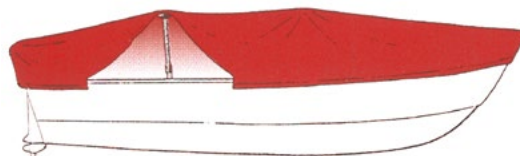

VISITA IL NOSTRO NUOVO WEBSITE



WWW.TREM.NET



VISIT OUR B2B AREA

CREATE A CUSTOMER ACCOUNT

CHECK AVAILABILITY & QUANTITY OF ITEMS

CHECK YOUR COMMERCIAL CONDITION

PLACE YOUR ORDER

TRACK YOUR ORDER STATUS

TRACK YOUR PAYMENT PROCESS

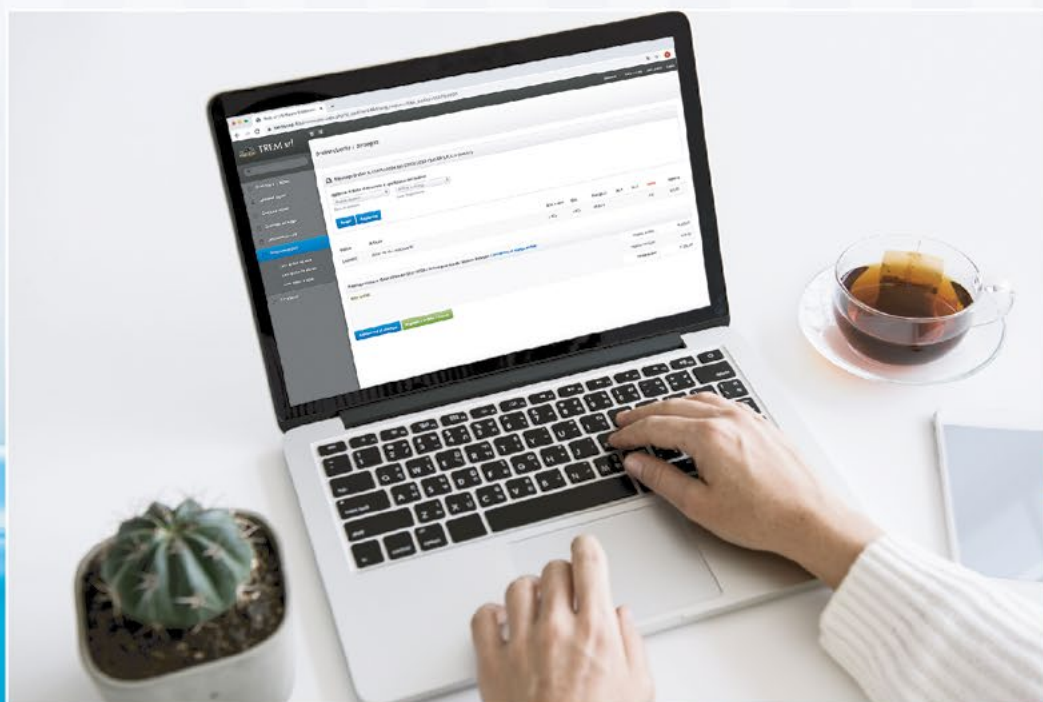

WWW.TREM.NET



RULLI ALAGGIO | PNEUMATIC ROLLERS

Rullo alaggio portata 200 kg.**Roller for boat towing max load 200 kg.**

Fabbricato in PVC.
Gonfiabile.

Manufactured in PVC.
Equipped with inflation valve.

| Articolo - Item | €/pc. | Ø mm. | Lunghezza Length mm. | kg. | kg. |
|-----------------|-------|-------|-------------------------|-----|-------|
| O 13 23 114 | | 200 | 1050 | 200 | 0,440 |

**Rullo alaggio portata 400 kg.****Roller for boat towing max load 400 kg.**

Fabbricato in PVC.
Gonfiabile.

Manufactured in PVC.
Equipped with inflation valve.

| Articolo - Item | €/pc. | Ø mm. | Lunghezza Length mm. | kg. | kg. |
|-----------------|-------|-------|-------------------------|-----|-------|
| O 13 30 125 | | 250 | 1600 | 400 | 0,540 |

**Rullo alaggio portata 450 kg.****Roller for boat towing max load 450 kg.**

Fabbricato in PVC.
Provvisto di valvola per il gonfiaggio.

Manufactured in PVC.
Equipped with inflation valve.

| Articolo - Item | €/pc. | Ø mm. | Lunghezza Length mm. | kg. | kg. |
|-----------------|-------|-------|-------------------------|-----|-------|
| O 13 30 400 | | 250 | 1250 | 450 | 0,650 |

**Rullo alaggio portata 600 kg.****Roller for boat towing max load 600 kg.**

Fabbricato in PVC + tessuto acrilico interno.
Provvisto di valvola per il gonfiaggio.

Manufactured in PVC + internal acrylic fabric.
Equipped with inflation valve.

| Articolo - Item | €/pc. | Ø mm. | Lunghezza Length mm. | kg. | kg. |
|-----------------|-------|-------|-------------------------|-----|-------|
| O 13 30 600 | | 300 | 1200 | 600 | 1,140 |



Ruote alaggio per gommoni Honda modello ribaltabile

Portata 100 Kg.
 Provviste di attacchi universali adatti per Honda o simili.
 Indicate per il varo e l'alaggio dei canotti pneumatici, mediante l'applicazione allo specchio di poppa. Gambi fabbricati in tubo di acciaio inox Aisi 316, provviste di ruote gonfiabili in gomma, con cerchi in nylon.
 Le ruote sono di grande sezione per evitare gli sprofondamenti nella sabbia.
Tubo ø 30 mm. - Ø ruote 260 mm.

Stern wheels for Honda rubber boats folding model

Maxi load 100 kg.
 These are equipped with joints enabling an easy lifting when seagoing, as well as an easy and safe falling into position when reentering.
 Stems and movements are made of stainless steel AISI 316.

Pipe ø 30 mm. - Ø wheels 260 mm.

| Articolo - Item | €/Coppia-Pair | Mod. | Tubo-Pipe Ø mm. | Ruote-Wheels Ø mm. | H mm. |
|-----------------|---------------|-------|--------------------|-----------------------|----------|
| O 08 36 038 | | Honda | 30 | 260 | 600 |



AISI 316 made by

**REALIZZATO IN COLLABORAZIONE CON
 MANUFACTURED IN COLLABORATION WITH**



COMPLETE WITH

SUGGESTED ITEM



Art. O1026000 (pag. 359)



Art. O1026085 (pag. 359)



Ruote alaggio per tender Zodiac modello ribaltabile

Portata 100 Kg.
 Provviste di giunti fabbricati in acciaio inox con meccanismo studiato per consentire un agevole sollevamento durante la navigazione ed un facile e sicuro ribaltamento al riutilizzo per il rientro.

Stern wheels for Zodiac tender folding model

Maxi load 100 kg.
 Stems and movements are made of Aisi 316 stainless steel.

| Articolo - Item | €/Coppia-Pair | Mod. | Tubo-Pipe Ø mm. | Ruote-Wheels Ø mm. | H mm. |
|-----------------|---------------|------|--------------------|--|----------|
| O 08 26 062 | | Mini | 30 | 260 | 560 |
| O 08 13 062 | | | | Kit di trasformazione per Kit for mod. Zodiac Cadet 80 x 130 mm. | |



AISI 316 made by

COMPLETE WITH

SUGGESTED ITEM



Art. O1026000 (pag. 359)



Art. O1026085 (pag. 359)



Art. O0813062 (pag. 354)



Ruote alaggio per gommoni Zodiac modello ribaltabile

Portata 180 Kg.
 Provviste di giunti fabbricati in acciaio inox con meccanismo studiato per consentire un agevole sollevamento durante la navigazione ed un facile e sicuro ribaltamento al riutilizzo per il rientro. Un robusto aggancio al centro dell'asta permette l'alaggio sicuro di grandi dimensioni.

Stern wheels for Zodiac rubber boats folding model

Max load 180 Kg.
 Stems and movements are made of stainless steel Aisi 316.
 Easy lifting when boating.
 Ø wheels 360 mm.

| Articolo - Item | €/Coppia-Pair | Mod. | Tubo-Pipe Ø mm. | Ruote-Wheels Ø mm. | H mm. |
|-----------------|---------------|-----------------------|--------------------|-----------------------|----------|
| O 08 36 094 | | Per-For Zodiac Futura | 30 | 360 | 800 |



AISI 316 made by

COMPLETE WITH

SUGGESTED ITEM



Art. O1040000 (pag. 359)



Art. O1036085 (pag. 359)

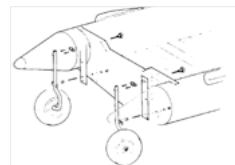
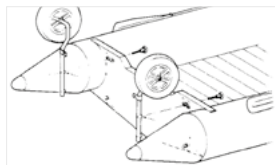

Coppia ruote alaggio per tender

Realizzate in materiale plastico antiurto. Ideali per il montaggio su superfici in legno, vetroresina o su telai di poppa in alluminio. Sistema di bloccaggio caricato a molla in esecuzione pesante. Bloccaggio in tre diverse posizioni. Facile installazione.

Pair of stern wheels for tender

Manufactured in shockproof plastic material. Three position folding system. Suitable for mounting on wooden surfaces, fibreglass or aluminium stern frames. Easy installation.

| Articolo - Item | €/Coppia-Pair | Aperte-Open mm. | kg. |
|-----------------|---------------|-----------------|-------|
| O 08 36 034 | | 100x270 | 2,820 |



Ruote alaggio per gommoni modello fisso

Provviste di attacchi universali adatti anche per mod. Zodiac.

Gambi fabbricati in tubo di acciaio inox Aisi 316, provviste di ruote gonfiabili in gomma, con cerchi in nylon.

Stern wheels for rubber boats steady model

Manufactured in stainless steel and in synthetic rubber.

| Articolo - Item | €/Coppia-Pair | Mod. | Tubo-Pipe Ø mm. | Ruote-Wheels Ø mm. | H mm. | kg. |
|-----------------|---------------|-----------|-----------------|--------------------|-------|-----|
| O 08 00 080 | | Universal | 30 | 360 | 770 | 150 |



COMPLETE WITH SUGGESTED ITEM



Art. O1040000 (pag. 359)



Art. O1036085 (pag. 359)



Ruote alaggio per gommoni modello ribaltabile

Provviste di giunti fabbricati in acciaio inox con meccanismo studiato per consentire un agevole sollevamento durante la navigazione ed un facile e sicuro ribaltamento al riutilizzo per il rientro.

Stern wheels for rubber boats folding model

Stems and movements are made of stainless steel Aisi 316.

| Articolo - Item | €/Coppia-Pair | Mod. | Tubo-Pipe Ø mm. | Ruote-Wheels Ø mm. | H mm. | kg. |
|-----------------|---------------|-----------|-----------------|--------------------|-------|-----|
| O 08 36 062 | | Universal | 30 | 360 | 770 | 100 |



COMPLETE WITH SUGGESTED ITEM



Art. O1040000 (pag. 359)



Art. O1036085 (pag. 359)



Ruote alaggio per gommoni modello ribaltabile

Provviste di giunti fabbricati in acciaio inox con meccanismo studiato per consentire un agevole sollevamento durante la navigazione ed un facile e sicuro ribaltamento al riutilizzo per il rientro.

Un robusto aggancio al centro dell'asta permette l'alaggio sicuro di grandi dimensioni.

Stern wheels for rubber boats folding model

Stems and movements are made of stainless steel Aisi 316.

| Articolo - Item | €/Coppia-Pair | Mod. | Tubo-Pipe Ø mm. | Ruote-Wheels Ø mm. | H mm. | kg. |
|-----------------|---------------|-----------|-----------------|--------------------|-------|-----|
| O 08 36 080 | | Universal | 30 | 360 | 700 | 180 |



COMPLETE WITH SUGGESTED ITEM



Art. O1040000 (pag. 359)



Art. O1036085 (pag. 359)



Ruote di poppa gemellari modello ribaltabile

Provviste di giunti fabbricati in acciaio inox con meccanismo studiato per consentire un agevole sollevamento durante la navigazione ed un facile e sicuro ribaltamento al riutilizzo per il rientro. Un robusto aggancio al centro dell'asta permette l'alaggio sicuro di grandi dimensioni.

Tubo ø 30 mm. - Ø ruote 260 mm.

Stern wheels for rubber boats folding model

Stems and movements are made of stainless steel Aisi 316.

Provided with 4 wheels for easy pulling.

Pipe ø 30 mm. - Ø wheels 260 mm.

| Articolo - Item | €/Coppia-Pair | Mod. | Tubo-Pipe Ø mm. | Ruote-Wheels Ø mm. | H mm. | kg. |
|-----------------|---------------|-----------|-----------------|--------------------|-------|-----|
| O 08 04 080 | | Universal | 30 | 260 | 700 | 200 |



COMPLETE WITH SUGGESTED ITEM



Art. O1026000 (pag. 359)



Art. O1026085 (pag. 359)



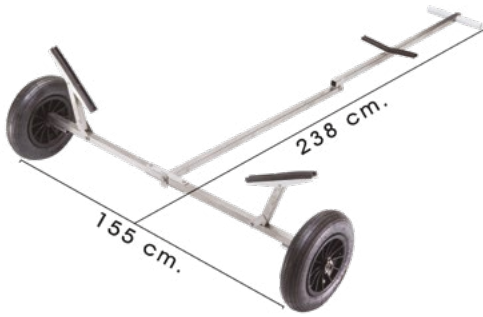

Carrello pieghevole in acciaio inox

Ruote pneumatiche, timone per alaggio imbarcazioni con peso inferiore ai 100 kg. e pianali in gomma sul piano di carico

Folding chariot in stainless steel

For boat haulage suitable to carry all boats with weight lower than 100 kg.

| Articolo - Item | €/pc. | Ruote-Wheels Ø mm. | kg. |
|-----------------|-------|--------------------|--------|
| O 08 36 040 | | 360 | 15,000 |



COMPLETE WITH SUGGESTED ITEM



Carrello anteriore per trasporto battelli pneumatici

Si fissa al maniglione anteriore dei canotti pneumatici. Grazie al movimento autosterzante, consente un facile alaggio anche su terreni impervi o sabbiosi. Smontabile per un facile trasporto. Fabbricato in tubo di acciaio zincato e provvisto di ruote pneumatiche in gomma a larga sezione.

Trolley for front transport of rubber boats

Fastening on front handle. Minimum overall dimension because it is folding. Provided with two rubber inflatable boats manufactured in zinc-coated steel pipe.

| Articolo - Item | €/pc. | Ruote-Wheels Ø mm. | kg. |
|-----------------|-------|--------------------|--------|
| O 08 36 110 | | 360 | 10,000 |



COMPLETE WITH SUGGESTED ITEM



Carrello anteriore snodato per trasporto battelli pneumatici

Si fissa al maniglione anteriore dei canotti pneumatici. Grazie al movimento autosterzante, consente un facile alaggio anche su terreni sabbiosi. Smontabile per un facile trasporto, snodato, consente di effettuare curve. Fabbricato in tubo di acciaio zincato e provvisto di ruote pneumatiche.

Articulated trolley for front transport of rubber boats

Fastening on front handle. Minimum overall dimension because it is folding. Provided with two rubber inflatable boats manufactured in zinc-coated steel pipe.

| Articolo - Item | €/pc. | Ruote-Wheels Ø mm. | kg. |
|-----------------|-------|--------------------|-------|
| O 08 26 110 | | 260 | 9,000 |



COMPLETE WITH SUGGESTED ITEM

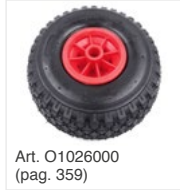

Carrelli per movimentazione imbarcazioni

Realizzati in acciaio verniciato colore nero.

Chariot for boat haulage

Manufactured in black colour painted steel.

| Articolo - Item | €/pc. | Mod. | Ruote-Wheels Ø mm. | kg. |
|-----------------|-------|--|--------------------|-------|
| O 08 17 114 | | Applicabile alla poppa Stern application | 170 | 2,820 |
| O 08 17 116 | | Per timonare carrelli portabarca For trolley pulling | 170 | 7,400 |



Carrello pieghevole «Kanguro Light»

Fabbricato in tubo di alluminio estruso anodizzato argento. Completo di sacca contenitore in tela impermeabile e ruote pneumatiche. Completamente pieghevole di minimo ingombro.

Folding trolley «Kanguro Light»

In anodized aluminium. With bag in waterproof nylon. Pneumatic wheels. Folding.

| Articolo - Item | €/pc. | Ruote-Wheels Ø mm. | ↳ Aperto-Open mm. | ↕ kg. | 📦 kg. |
|-----------------|-------|--------------------|-------------------|-------|-------|
| O 00 28 100 | | 280 | 630x680x1000H | 60 | 3,500 |



COMPLETE WITH SUGGESTED ITEM



Art. O1026000 (pag. 359)



Art. O1026085 (pag. 359)



Carrello pieghevole «Kanguro Plus»

Ruote in plastica per sabbia.

Folding trolley «Kanguro Plus»

Plastic wheels for sand.

| Articolo - Item | €/pc. | ↳ Aperto-Open mm. | ↳ Chiuso-Closed mm. | 📦 kg. |
|-----------------|-------|-------------------|---------------------|-------|
| O 00 50 130 | | 130x50x120 H | 23x50x78H | |



COMPLETE WITH SUGGESTED ITEM



Art. O1026000 (pag. 359)



Art. O1026085 (pag. 359)



Carrello pieghevole porta surf/canoa

Ruote pneumatiche Ø 280 mm. Fabbricato in alluminio anodizzato.

Canoe and wind-surf folding trolley

Pneumatic wheels Ø 280 mm. Manufactured in anodized aluminium.

| Articolo - Item | €/pc. | H mm. | Larghezza-Width mm. | ↕ kg. | 📦 kg. |
|-----------------|-------|-------|---------------------|-------|-------|
| O 08 28 078 | | 40 | 68 | 40 | 2,800 |



COMPLETE WITH SUGGESTED ITEM



Art. O1026000 (pag. 359)



Art. O1026085 (pag. 359)



WINDSURF TROLLEY

RULLI DI RICAMBIO PER CARRELLI | SPARE ROLLERS FOR TROLLEYS

Rullo centrale in poliuretano Polyurethane central roller

| Articolo - Item | €/pc. | Foro-Hole Ø mm. | Length mm. | kg. |
|-----------------|-------|--------------------|---------------|-------|
| O 08 08 025 | | 17 | 125 | 0,360 |



Rullo laterale in poliuretano Polyurethane side roller

| Articolo - Item | €/pc. | Foro-Hole Ø mm. | Length mm. | kg. |
|-----------------|-------|--------------------|---------------|-------|
| O 08 08 027 | | 18 | 200 | 1,100 |



Rullo in poliuretano Polyurethane roller

| Articolo - Item | €/pc. | Ø mm. | Foro-Hole Ø mm. | Length mm. | kg. |
|-----------------|-------|-------|--------------------|---------------|-------|
| O 08 09 026 | | 110 | 25 | 72 | 0,480 |



Supporto in poliuretano Polyurethane holder

| Articolo - Item | €/pc. | mm. | kg. |
|-----------------|-------|-------|-------|
| O 08 08 031 | | 70x36 | 0,290 |



Rullo centrale in PVC central roller PVC

| Articolo - Item | €/pc. | Foro-Hole Ø mm. | mm. | kg. |
|-----------------|-------|--------------------|-------|-------|
| O 08 09 001 | | 14 | 76x80 | 0,320 |



Rullo centrale in PVC central roller PVC

| Articolo - Item | €/pc. | Foro-Hole Ø mm. | mm. | kg. |
|-----------------|-------|--------------------|-----|-------|
| O 08 09 002 | | 14 | 100 | 0,350 |
| O 08 09 003 | | 14 | 125 | 0,350 |



Rullo laterale in PVC side roller PVC

| Articolo - Item | €/pc. | Foro-Hole Ø mm. | mm. | kg. |
|-----------------|-------|--------------------|-----|-------|
| O 08 09 006 | | 17 | 200 | 1,000 |
| O 08 09 008 | | 17 | 300 | 1,000 |



Supporto in PVC PVC holder

| Articolo - Item | €/pc. | Foro-Hole Ø mm. | mm. | kg. |
|-----------------|-------|--------------------|-----|-------|
| O 08 09 450 | | 14 | 73 | 0,700 |

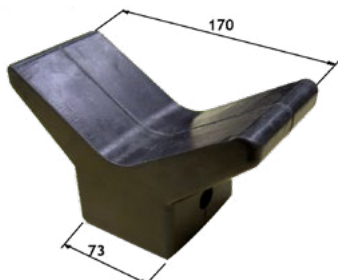

Rullo laterale in PVC side roller PVC

| Articolo - Item | €/pc. | Foro-Hole Ø mm. | mm. | kg. |
|-----------------|-------|--------------------|-----|-------|
| O 08 09 290 | | 12 | 230 | 0,700 |



Barra Ø 16 mm. Roller holder bar per rulli in acciaio zincato Ø 16 mm.

Completa di terminali. With end fittings.

| Articolo - Item | €/pc. | Per rulli-Roller mm. | kg. |
|-----------------|-------|----------------------|-------|
| O 08 11 284 | | 250 | 0,460 |
| O 08 11 285 | | 300 | 0,550 |



Ruotini d'appoggio

Stern wheels

| Articolo - Item | €/pc. | Tubo-Pipe Ø mm. | H mm. | ↕ Ruota-Wheel mm. | Mod. Ruota-Wheel | kg. |
|-----------------|-------|--------------------|----------|-------------------|------------------|-------|
| O 10 41 500 | | 35 | 480-700 | Ø 160x40 | Plastica-Plastic | 2,870 |
| O 10 41 501 | | 48 | 600-850 | Ø 200x50 | Metallo-Metal | 4,490 |
| O 10 41 503 | | 48 | 620 | Ø 260x85 | Plastica-Plastic | 3,950 |
| O 10 41 507 | | 48 | 620 | Ø 260x85 | Metallo-Metal | 4,420 |
| O 10 48 370 | | 48 | 370 | Ø 200x50 | Plastica-Plastic | 4,800 |



O1041500

SUGGESTED ITEM



Art. O1041531
(pag. 362)



O1041501

COMPLETE WITH



Art. O1041540
(pag. 359)

SUGGESTED ITEM



Art. O1041532
(pag. 362)



O1041503

COMPLETE WITH



Art. O1041542
(pag. 359)

SUGGESTED ITEM



Art. O1041532
(pag. 362)



O1041507

COMPLETE WITH



Art. O1041543
(pag. 359)

SUGGESTED ITEM



Art. O1041532
(pag. 362)



O1048370

SUGGESTED ITEM



Art. O1041532
(pag. 362)

Ruote di ricambio per carrelli «TR.EM.»

Stern wheels for «TR.EM.» trolleys

| Articolo - Item | €/pc. | ↕ Ruota-Wheel mm. | Foro-Hole Ø mm. | Cerchio-Rim | Pneumatico-Tire | kg. |
|-----------------|-------|-------------------|--------------------|----------------------------------|-----------------------|-------|
| O 10 10 000 | | Ø 80x20 | 10 | Nylon | Rigido-Stiff | 0,200 |
| O 10 15 000 | | Ø 140x40 | 15 | Nylon | Rigido-Stiff | 0,300 |
| O 10 26 000 | | Ø 260x85 | 20 | Nylon | Gonfiabile-Inflatable | 0,500 |
| O 10 40 000 | | Ø 360x85 | 25-30 | Nylon | Gonfiabile-Inflatable | 2,000 |
| O 10 39 000 | | Ø 390x140 | 25-30 | Plastica-Plastic | Rigido-Stiff | 3,000 |
| O 10 26 085 | | Ø 260x85 | 20 | Nylon | PU rigido-Stiff PU | 0,900 |
| O 10 36 085 | | Ø 360x85 | 25-30 | Nylon | PU rigido-Stiff PU | 1,500 |
| O 10 41 540 | | Ø 200x50 | 15 | Acciaio zincato-Galvanized steel | PU rigido-Stiff PU | |
| O 10 41 543 | | Ø 260x85 | 15 | Acciaio verniciato-Painted steel | Gonfiabile-Inflatable | |
| O 10 41 542 | | Ø 260x85 | 15 | Nylon | Gonfiabile-Inflatable | |



O1010000



O1015000



O1026000



O1040000



O1039000



O1026085



O1036085



O1041540



O1041543



O1041542

Arganello per alaggio imbarcazioni

In acciaio zincato.
Ingranaggi in acciaio temperato e cuscinetti autolubrificanti.
Marcia indietro e folle ad azionamento rapido.

Boat haulage winch

In galvanized steel.
Gears in tempered steel.
Reverse and neutral quick operating.

| Articolo - Item | €/pc. | kg. | Demoltiplica Gear ratio | mm. | Marcia-Gear | Cavo ideale Suitable cable | Cavo cinghia suggerito Suggested belt cable | kg. |
|-----------------|-------|------|-------------------------|---------|---|----------------------------|---|-------|
| N 08 00 027 | | 350 | 3.2:1 | 80x120 | Avanti/Indietro/Folle-Forward/Reverse/Neutral | Ø3-Ø5 | N0448750 | 1,800 |
| N 08 00 045 | | 450 | 4:1 | 140x88 | Avanti/Indietro/Folle-Forward/Reverse/Neutral | Ø3-Ø5 | N0448750 | 2,800 |
| N 08 00 065 | | 540 | 4:1 | 140x88 | Avanti/Indietro/Folle-Forward/Reverse/Neutral | Ø3-Ø5 | N0448750 | 2,800 |
| N 08 00 063 | | 630 | 4:1 | 140x88 | Avanti/Indietro/Folle-Forward/Reverse/Neutral | Ø3-Ø5 | N0448750 | 3,900 |
| N 08 00 120 | | 900 | 4:1/10:1 | 185x120 | Avanti/Indietro/Folle-Forward/Reverse/Neutral | Ø5-Ø8 | N0448750-C3550750 | 4,750 |
| N 08 00 125 | | 1125 | 5:1/12:1 | 200x120 | Avanti/Indietro/Folle-Forward/Reverse/Neutral | Ø5-Ø8 | N0448750-C3550750 | 4,800 |

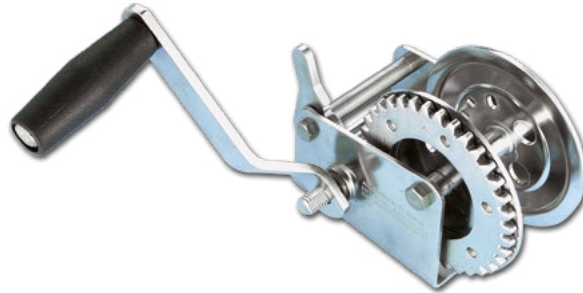

SUGGESTED ITEM



Arganello per alaggio imbarcazioni

Carcassa in acciaio zinco/cromato. Pignoni in acciaio temperato ad alta resistenza.
Boccole autolubrificanti. Maniglie rinforzate. Molle in acciaio. Gruppo ingranaggi carenato.
Verniciato nero con polveri epossidiche.

Boat haulage winch

In galvanized steel.
Gears in tempered steel.
Reverse and neutral quick operating.

| Articolo - Item | €/pc. | kg. | Rapporto Ratio | mm. | Marcia-Gear | Capacità cavo Cable capacity mt. | Cavo cinghia suggerito Suggested belt cable |
|-----------------|-------|------|----------------|---------|---|----------------------------------|---|
| N 08 18 647 | | 900 | 4:1 e 10:1 | 175x125 | Avanti/Indietro/Folle-Forward/Reverse/Neutral | 30 (Ø5 mm)/15 (Ø8 mm) | C3550750 |
| N 08 17 648 | | 1125 | 5:1 e 12:1 | 175x125 | Avanti/Indietro/Folle-Forward/Reverse/Neutral | 30 (Ø5 mm)/15 (Ø8 mm) | C3550750 |



- I carichi trazione max degli arganelli si riferiscono ad una sola spirale di cavo
- Completo di freno a mano rapido
- Fornito privo di cavo cinghia

- The max pull of the winches refers to use with one cable
- Complete with quick manual brake.
- Without belt cable



SUGGESTED ITEM



ACCESSORI PER ARGANI | ACCESSORIES FOR TRAILER WINCHES

Nastri in nylon per argani

Indicati per argani manuali. Sostituiscono i tradizionali cavi in acciaio evitando i difetti dovuti all'aggrovigliamento e rottura dei fili.
Completo di moschettone.

Trailer winch belt in nylon

Suitable for hand operated winches.
With snap hook.
Avoids problems of twisting.

| Articolo - Item | €/pc. | Larghezza Width mm. | Lunghezza Length mt. | kg. |
|-----------------|-------|---------------------|----------------------|------|
| C 35 50 750 | | 50 | 7,5 | 1500 |



Cavo in acciaio per argani

Completi di moschettone.

Trailer winch cable

With snap hook.

| Articolo - Item | €/pc. | Ø mm. | Lunghezza Length mt. | kg. | kg. |
|-----------------|-------|-------|----------------------|------|-------|
| N 04 48 750 | | 5 | 7,5 | 1200 | 0,900 |



Telecomando per argani elettrici

Remote control for electric winch

| Articolo - Item | €/pc. | Cavo Cable mt. | Ideale per Suitable for |
|-----------------|-------|----------------|-------------------------|
| N 08 02 153 | | 5 | N0812153 |
| N 08 02 464 | | 5 | N0812464 |



NEW



Arganello elettrico per alaggio

Caratteristiche tecniche:

- Marci avanti, folle, marcia indietro
- Comando a distanza con cavo 5 m + rulli guida cavo
- Circuit breakers per prevenire sovraccarichi al motore
- Freno dinamico e meccanico
- 12V

Boat haulage winch

Main features:

- Forward/Reverse/Neutral gears
- Remote control with 5 m cable + cable guide rollers
- Circuit breakers to prevent motor overloads
- Dynamic and mechanical brake
- 12V

| Articolo - Item | €/pc. | Rapporto Ratio | Motore Engine W | Cavo Cable | Consumo Amp Low Speed | Consumo Amp Max Speed | Portata traino barca su carrello kg. | Portata traino barca in acqua kg. | Portata traino barca su terreno kg. | kg. |
|-----------------|-------|----------------|-----------------|-------------------|-----------------------|-----------------------|--------------------------------------|-----------------------------------|-------------------------------------|--------|
| N 08 32 113 | | 166:1 | 800 | Ø 5,5 mm x 15 mt. | 25 | 300 | 5500 | 5000 | 2000 | 15,000 |

1 12V

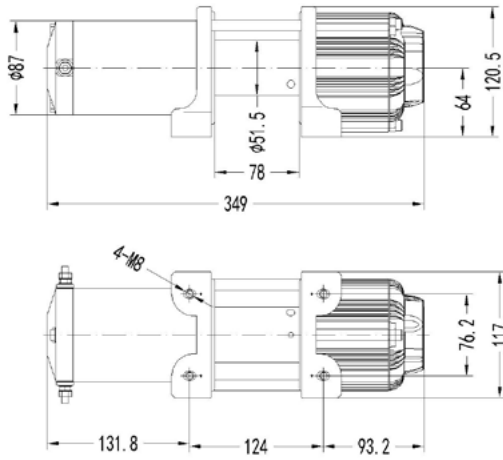

Arganello elettrico per alaggio

Caratteristiche tecniche:

- Marci avanti, folle, marcia indietro
- Comando a distanza con cavo 5 m
- Circuit breakers per prevenire sovraccarichi al motore
- Freno dinamico e meccanico
- 12V

Boat haulage winch

Main features:

- Forward/Reverse/Neutral gears
- Remote control with 5 m cable
- Circuit breakers to prevent motor overloads
- Dynamic and mechanical brake
- 12V

| Articolo - Item | €/pc. | Rapporto Ratio | Motore Engine W | Cavo Cable | Consumo Amp Low Speed | Consumo Amp Max Speed | Portata traino barca su carrello kg. | Portata traino barca in acqua kg. | Portata traino barca su terreno kg. | kg. |
|-----------------|-------|----------------|-----------------|----------------|-----------------------|-----------------------|--------------------------------------|-----------------------------------|-------------------------------------|-------|
| N 08 12 153 | | 258:1 | 550 | Ø 4 mm x 8 mt. | 20 | 100 | 3000 | 2300 | 1000 | 5,000 |

1 12V

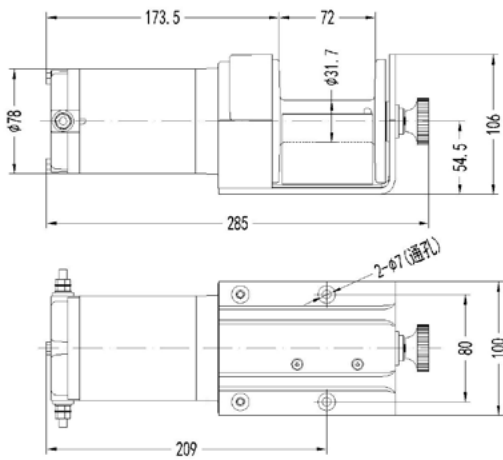

COMPLETE WITH



Art. N0802153 (pag. 360)

Arganello elettrico per alaggio

Caratteristiche tecniche:

- Marci avanti, folle, marcia indietro
- Comando a distanza con cavo 5 m
- Circuit breakers per prevenire sovraccarichi al motore
- Freno dinamico e meccanico
- 12V

Boat haulage winch

Main features:

- Forward/Reverse/Neutral gears
- Remote control with 5 m cable
- Circuit breakers to prevent motor overloads
- Dynamic and mechanical brake
- 12V

| Articolo - Item | €/pc. | Rapporto Ratio | Motore Engine W | Cavo Cable | Consumo Amp Low Speed | Consumo Amp Max Speed | Portata traino barca su carrello kg. | Portata traino barca in acqua kg. | Portata traino barca su terreno kg. | kg. |
|-----------------|-------|----------------|-----------------|----------------|-----------------------|-----------------------|--------------------------------------|-----------------------------------|-------------------------------------|--------|
| N 08 12 464 | | 464:1 | 450 | Ø 5 mm x 9 mt. | 15 | 50 | 3000 | 2300 | 1000 | 17,000 |

1 12V **CON CONTROLLO REMOTO**
WITH REMOTE CONTROL

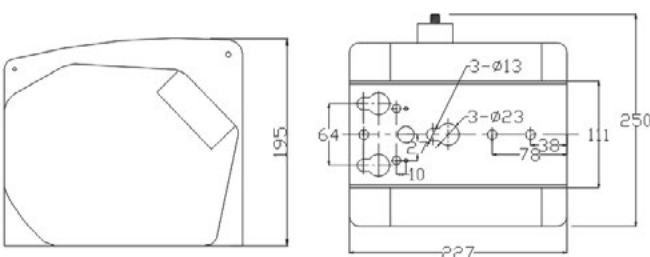

COMPLETE WITH



Art. N0802464 (pag. 360)



Supporto per ruotino

Wheel support

| Articolo - Item | €/pc. | Tubo-Hose Ø mm. | Articolo-Item per ruotino-for wheel | ↑ mm. |
|-----------------|-------|----------------------------|--|--------|
| O 10 41 531 | | 35 (regolabile-adjustable) | O1041500 | 54x130 |
| O 10 41 532 | | 48 | O1048370-O1041501 O1041503-O1041507 | |



Sfera per gancio traino

Sphere

| Articolo - Item | €/pc. | Versione-Version |
|-----------------|-------|--------------------------|
| O 10 10 703 | | Regolamentare-Regulatory |



Gancio traino

Sphere

| Articolo - Item | €/pc. | Versione-Version |
|-----------------|-------|-----------------------|
| O 10 11 703 | | A squadra-Right angle |



Lucchetto blocca gancio

Hook locking device

| Articolo - Item | €/pc. | Versione-Version |
|-----------------|-------|----------------------|
| O 10 00 268 | | Universale-Universal |



Cuneo di sicurezza

Safety chock

| Realizzato in materia plastica. | | Made in plastic. |
|---------------------------------|-------|------------------|
| Articolo - Item | €/pc. | ↑ mm. |
| O 10 90 220 | | 220x100x90 |



Antifurto per carrello

Applicabile sul giunto sferico con il carrello sganciato.

Antitheft device for trailer

To be applied on the ball joint when the transport cart is disconnected.

| Articolo - Item | €/pc. | Versione-Version |
|-----------------|-------|----------------------|
| O 10 00 880 | | Universale-Universal |



Gancio omologato per rimorchio

Type-approved tow hooks, universal version

| Articolo - Item | €/pc. | Canale Ø mm. | Per carichi fino a For loads up to kg. | Sfera-Sphere Ø mm. |
|-----------------|-------|------------------|--|--------------------|
| O 10 50 075 | | tondo-round 60 | 750 | 50 |
| O 10 50 076 | | quadro-square 50 | 750 | 50 |
| O 10 60 075 | | quadro-square 60 | 750 | 50 |



Soffietto in gomma per gancio rimorchio

Rubber bellow for hauling hook

| Articolo - Item | €/pc. | Versione-Version |
|-----------------|-------|----------------------|
| O 10 00 541 | | Universale-Universal |



Coprisfera ad incastro

Pratica, universale e resistente agli agenti atmosferici.

Towing ball joint cover

Practical, universal and weather resistant.

| Articolo - Item | €/pc. | Versione-Version |
|-----------------|-------|----------------------|
| O 10 00 898 | | Universale-Universal |



PANNELLI CARICHI SPORGENTI | PANELS FOR EXCEEDING LOADS

Pannello per «Carichi sporgenti»

Obbligatorio per il trasporto dei carichi sporgenti quando questi superano la lunghezza della vettura concessa dal codice stradale.

Panel for exceeding loads

Compulsory when transporting exceeding loads.

| Articolo - Item | €/pc. | Mod. | ↕ cm. | 📦 pcs. | 📦 kg. |
|-----------------|-------|----------------------------|-------|--------|-------|
| D 39 20 020 | | Conforme Compliant | 50x50 | 5 | 0,800 |
| D 39 50 050 | | Omologato Type-approved | 50x50 | 10 | 1,100 |



D3950050



D3920020

ACCESSORI PER CARRELLI | ACCESSORIES FOR TROLLEYS

Fanale d'ingombro

Clearance light

| Articolo - Item | €/pc. | Descrizione Description | Colore Colour |
|-----------------|-------|--|---------------------------|
| O 10 00 610 | | Fanale laterale base piana Flat base side light | Bianco-Rosso White-Red |
| O 10 45 610 | | Fanale laterale base gomma Rubber base side light | Bianco-Rosso White-Red |



Fanale posteriore

Rear light

| Articolo - Item | €/pc. | Descrizione Description | Funzione Function |
|-----------------|-------|----------------------------|--|
| O 10 03 550 | | DX-Right SX-Left | posizione / stop / direzione / luce targa position / stop / direction / numberplate light |



Kit luci posteriori

Cavo centrale: 7,5 m a 5 poli.
Cavo fanale - fanale 2,5 m.
Fanale dx: posizione + stop + freccia + luca targa
Fanale sx: posizione + stop + freccia. Spina 7 poli

| Articolo - Item | €/pc. |
|-----------------|-------|
| O 10 75 052 | |
| O 10 75 034 | |



Rear light kit

Central cable: 7,5 m, 5 poles.
Spot light cable 2,5 m.
Right spotlight: position + stop + direction + numberplate light
Left spotlight: position + stop + direction. 7-pole plug.

| Descrizione-Description |
|---|
| Fissaggio magnetico-Magnetic mounting |
| Fissaggio magnetico + Triangoli riflettenti Magnetic mounting + Reflecting triangles |



Fanale a LED

LED light

| Articolo - Item | €/pc. | Volts | Descrizione-Description | Funzione-Function |
|-----------------|-------|-------|---|--|
| O 10 24 404 | | 12-24 | Posteriore dx/sx-Right/left rear light | posizione / stop / direzione-position / stop / direction |
| O 10 12 004 | | 12 | Fanale posteriore dx/sx a 4 luci 4-light right/left rear light | posizione / stop / direzione / luce targa position / stop / direction / numberplate light |



Fanale a LED

LED light

| Articolo - Item | €/Kit. | Kit with: | Volts | Descrizione-Description | Funzione-Function |
|-----------------|--------|---------------------------|-------|---|--|
| O 10 24 022 | | 2 red dx/sx+2 white dx/sx | 12-24 | Fanale d'ingombro laterale 45°-45° side light | ingombro bianco/rosso - size white/red |
| O 10 24 028 | | 2 red dx/sx+2 white dx/sx | 12-24 | Fanale d'ingombro laterale 90°-90° side light | ingombro bianco/rosso - size white/red |



O1024404

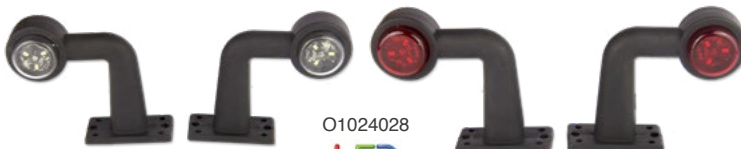

O1024028
LED



O1024022
LED



O1012004

Barra in plastica con luci al LED

Cavo centrale da 5 m.
Fanale dx-sx: posizione, stop, freccia luce targa + triangoli riflettenti.

Plastic bar with LED lights

5 m. central cable.
Left/right light: position, stop, direction, immatriculation plate + reflecting triangles.

| Articolo - Item | €/pc. | Descrizione-Description |
|-----------------|-------|-----------------------------------|
| O 10 55 120 | | Barra plastica-Plastic bar 122 cm |



Kit luci a led fissaggio magnetico

Cavo centrale: 7,5 m a 5 poli, cavo fanale - fanale 2,5 m.
Tipo: posizione, stop, freccia, luce targa.

LED light kit magnetic mounting

Central cable: 7,5 m, 5 poles.
2,5 m. cable spotlight to spotlight.
Type: position, stop, direction, plate light.

| Articolo - Item | €/pc. | Volts | Triangoli riflettenti Reflecting triangles | Spina poli Plug poles |
|-----------------|-------|-------|---|--------------------------|
| O 10 07 534 | | 12-24 | SI | 7 |



Catadiottri

Catadioptric lights

| Articolo - Item | €/pc. | Mod. | mm. |
|-----------------|-------|--------------------------------------|--|
| O 10 70 060 | | Arancione-Orange | 70 |
| O 10 74 060 | | Bianco-White | 70 |
| O 10 70 160 | | Arancione adesivo Adhesive orange | 70 |
| O 10 74 160 | | Bianco adesivo Adhesive white | 70 |
| O 10 03 070 | | Triangolare-Triangular | 152x110 interasse fori bore centre distance |



Barra posteriore in plastica con luci

Cavo centrale: 5 m a 5 poli.
Fanale dx: posizione + stop + freccia + luce targa.
Fanale sx: posizione + stop + freccia.
Spina 7 poli.
Triangoli riflettenti.

Rear plastic bar with lights

Central cable: 5 m, 5 poles.
Right spotlight: position + stop + direction + numberplate light.
Left spotlight: position + stop + direction.
7-pole plug.
Reflecting triangles.

| Articolo - Item | €/pc. | Descrizione-Description |
|-----------------|-------|-----------------------------------|
| O 10 05 120 | | Barra plastica-Plastic bar 122 cm |



VISIT OUR B2B AREA

- CREATE A CUSTOMER ACCOUNT
- CHECK AVAILABILITY & QUANTITY OF ITEMS
- CHECK YOUR COMMERCIAL CONDITION
- PLACE YOUR ORDER
- TRACK YOUR ORDER STATUS
- TRACK YOUR PAYMENT PROCESS



WWW.TREM.NET



RETI PORTA OGGETTI | OBJECT HOLDER NETS

Rete porta GPS

Cornice in ABS UV resistant.
Rete in poliestere.

| Articolo - Item | €/pc. |
|-----------------|-------|
| N 17 74 126 | |
| N 17 80 126 | |

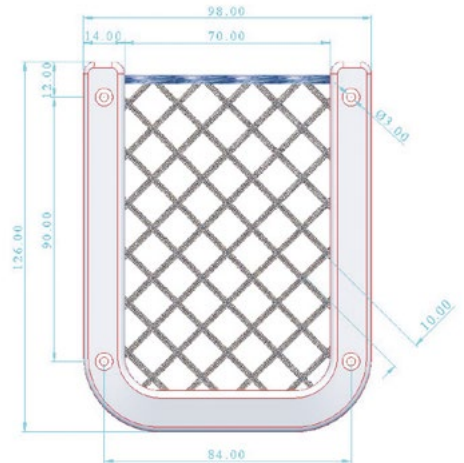

GPS holder net

Frame manufactured in UV resistant ABS.
Polyester net.

| Colore-Colour | kg. |
|----------------|-------|
| ■ Bianco-White | 0,030 |
| ■ Nero-Black | 0,030 |

Rete porta cellulare

Cornice in ABS UV resistant.
Rete in poliestere.

| Articolo - Item | €/pc. |
|-----------------|-------|
| N 17 74 164 | |
| N 17 80 164 | |

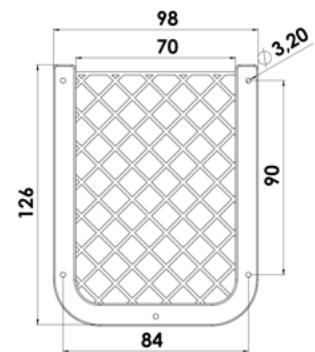

Mobile phone holder net

Frame manufactured in UV resistant ABS.
Polyester net.

| Colore-Colour | kg. |
|----------------|-----|
| ■ Bianco-White | |
| ■ Nero-Black | |

Rete porta-oggetti con cornice Elastic net as object-holder

Fabbricate con rete di contenimento e filetto superiore in corda elastica.

Manufactured with net and upper line in elastic cord.

| Articolo - Item | €/pc. | Colore-Colour | mm. | kg. |
|-----------------|-------|---------------|---------|-------|
| Z 00 18 302 | | ■ Nero-Black | 180x302 | 0,300 |
| Z 00 64 695 | | ■ Nero-Black | 210x415 | 0,300 |



Mini retina elastica con cornice Mini elastic net with ABS frame

Colore nero.

Black colour.

| Articolo - Item | €/pc. | mm. |
|-----------------|-------|--------|
| N 17 80 017 | | 150x80 |



Rete porta oggetti

Cornice in ABS.
Rete in poliestere.

Object holder net

Frame manufactured in ABS.
Polyester net.

| Articolo - Item | €/pc. | Colore-Colour | mm. | kg. |
|-----------------|-------|--|---------|-------|
| Z 00 74 370 | | <input type="checkbox"/> Bianco-White | 180x365 | 0,390 |
| Z 00 18 370 | | <input checked="" type="checkbox"/> Nero-Black | 180x365 | 0,390 |

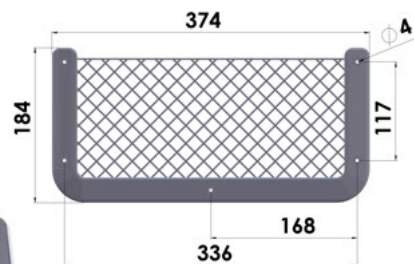

Tasca porta oggetti con retina in gomma

Cornice in ABS.
Rete in PVC.

Rectangular elastic net in rubber as object holder

Frame manufactured in ABS.
PVC net.

| Articolo - Item | €/pc. | Colore cornice Frame colour | Colore retina Net colour | mm. | kg. |
|-----------------|-------|--|--|------------|-------|
| Z 00 74 115 | | <input type="checkbox"/> Bianco-White | <input type="checkbox"/> Bianco-White | 270x115x32 | 0,210 |
| Z 00 80 115 | | <input checked="" type="checkbox"/> Nero-Black | <input checked="" type="checkbox"/> Nero-Black | 270x115x32 | 0,210 |

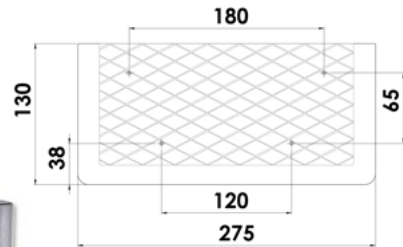

Tasca porta oggetti

Realizzata in ABS.

Object holder pocket

Manufactured in ABS.

| Articolo - Item | €/pc. | Colore-Colour | Mod. | kg. |
|-----------------|-------|--|----------------------------|-------|
| D 10 74 370 | | <input type="checkbox"/> Bianco-White | Tasca a parete-Wall pocket | 0,400 |
| D 10 18 370 | | <input checked="" type="checkbox"/> Nero-Black | Tasca a parete-Wall pocket | 0,400 |



D1074370



D1018370

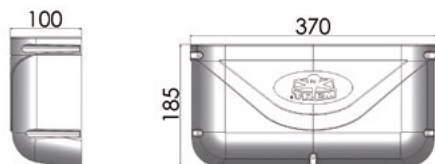

RETI PORTA OGGETTI | OBJECT HOLDER NETS

Rete di carico e contenimento colore nero

Completa di attacchi autoavvitanti.

Load and containment net black colour

Complete with self-tapping fittings.

| Articolo - Item | €/kit |
|-----------------|-------|
| Z 00 80 114 | |

| mm. |
|---------|
| 900x350 |

| kg. |
|-------|
| 0,030 |

madeby 

COMPLETE WITH

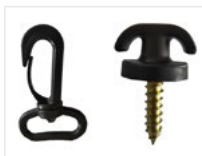

ATTACCHI-FITTINGS

Rete di carico elastica con bande di contenimento colore nero

Completa di 4 bottoni avvitabili.

Load elastic net with containment bands black colour

Complete with 4 screw-on buttons.

| Articolo - Item | €/kit |
|-----------------|-------|
| Z 00 80 040 | |

| mm. |
|---------|
| 400x250 |

| kg. |
|-----|
| |

madeby 

COMPLETE WITH



BOTTONI-BUTTONS
N58 01 004
(pag. 350)

Reti elastiche rettangolari porta oggetti

Tessuta a rete con treccia di fibra sintetica. Con dette reticelle ogni spazio nelle imbarcazioni può essere razionalmente sfruttato quale ripostiglio degli oggetti più disparati. Completa di ganci Art. A2100020 per fissaggio.

Elastic net to carry various objects

Net manufactured in string of unalterable synthetic material. Supplied all around with a rubber cord and 4 nylon hooks. Complete with Item N. A2100020 for fastening.

| Articolo - Item | €/kit |
|-----------------|-------|
| Z 00 00 150 | |
| Z 00 00 200 | |
| Z 00 00 280 | |

| mm. |
|-----------|
| 300 x 200 |
| 400 x 200 |
| 700 x 400 |

| pcs. |
|------|
| 50 |
| 100 |
| 50 |

| kg. |
|-------|
| 0,200 |
| 0,250 |
| 0,380 |

madeby 

COMPLETE WITH



Art. A2100020
(pag. 42)

RETI CUCLETTE | PROTECTION NETS FOR BED

Rete protezione cuccette

Con ganci in nylon Art. A2100020 ed elastico perimetrale.

Protection net for bed

With nylon hooks Art. A2100020 and perimetric elastic.

| Articolo - Item | €/kit |
|-----------------|-------|
| Z 00 00 220 | |

| rete-net mt. |
|--------------|
| 2x0,60H |

| kg. |
|-------|
| 0,335 |

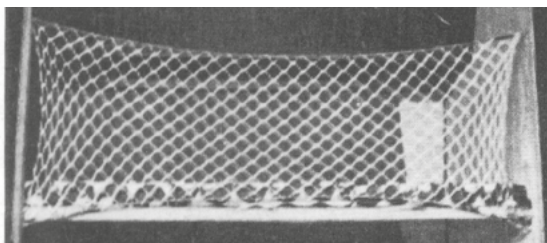
madeby 

COMPLETE WITH



Art. A2100020
(pag. 42)

RETI BATTAGLIOLE | HANDRAIL NETS

Rete battagliole cucita

Colore bianco.
Realizzata in poliestere.

Handrail net

Manufactured in polyester.
White colour.

| Articolo - Item | €/mt. | €/m ² | Rotolo-Reel mt. | H a riposo mm. | H max mm. | Rombi Rhombus mm. |
|-----------------|-------|------------------|-----------------|----------------|-----------|-------------------|
| Z 00 00 080 | | | 30 | 250 | 600 | 25 |
| Z 00 00 250 | | | 100 | 250 | 600 | 25 |

made by 

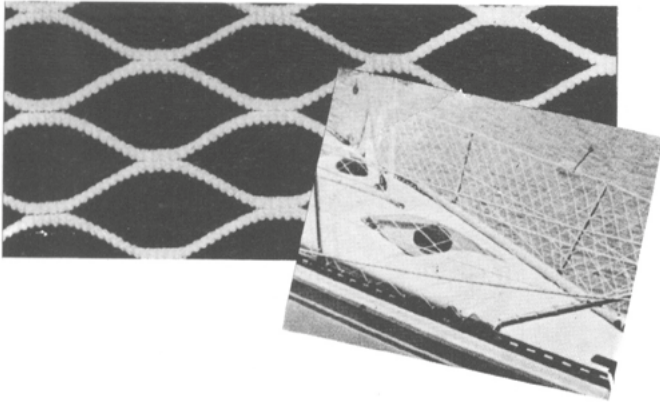

Rete battagliole annodata

Colore bianco. Realizzata in Nylon.
Altezza reale grazie alle maglie quadre.

Handrail net

Manufactured in nylon.
White colour.

| Articolo - Item | €/mt. | €/m ² | Rotolo-Reel mt. | H a riposo mm. | H max mm. | Rombi Rhombus mm. |
|-----------------|-------|------------------|-----------------|----------------|-----------|-------------------|
| Z 01 05 025 | | | 30 | 250 | 600 | 25 |
| Z 01 05 100 | | | 100 | 250 | 600 | 25 |

made by 

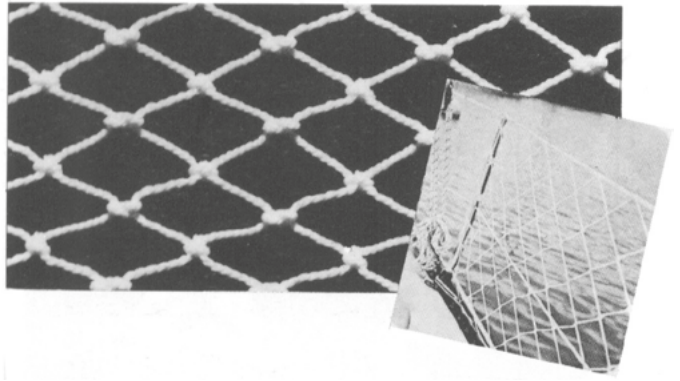

PORTA MANIGLIE WINCH | WINCH HANDLE POCKETS

Porta maniglie winch in plastica Plastic winch handle pockets

| Articolo - Item | €/pc. | L mm. | Colore Colour | Mod. |
|-----------------|-------|-------|---------------|------|
| N 62 00 500 | | 300 | Bianco-White | MIDI |
| N 62 00 700 | | 350 | Bianco-White | BIG |



Porta maniglie winch «Soft» Winch handle pockets «Soft»

| Articolo - Item | €/pc. | L mm. | Colore Colour | Mod. | kg. |
|-----------------|-------|-------|---------------|------|-------|
| N 62 63 572 | | 280 | Bianco-White | MIDI | 0,380 |
| N 62 63 573 | | 310 | Bianco-White | BIG | 0,350 |



VISITA IL NOSTRO
NUOVO WEBSITE



WWW.TREM.NET



PORTABICCHIERI | GLASS HOLDERS

Portabicchieri/Portalattine

Glass & can holder

Realizzato in acciaio inox stampato e lucidato. Si incassa sul cruscotto o console di guida.

Manufactured in polished stainless steel. For mounting on dashboard.

| Articolo - Item | €/pc. | Ø interno inner mm. | Ø esterno outer mm. | Profondità Depth mm. | Ø Incasso Recess mm. |
|-----------------|-------|---------------------|---------------------|----------------------|----------------------|
| D 17 32 075 | | 68 | 88 | 42 | 70 |



AISI 316 NEW



Portabicchieri in acciaio inox

Stainless steel glass holder

Doppio diametro per contenere bottiglie e nuove lattine. Foro di drenaggio con portagomma. Bordo lucidato a specchio. Fornito con guarnizione autoadesiva.

Double diameter to house bottles and cans. Drain hole with hose adaptor. Supplied with self-adhesive seal for fast mounting.

| Articolo - Item | €/pc. | Versione-Version |
|-----------------|-------|--|
| D 17 15 005 | | Standard |
| D 17 15 007 | | Perimetro interno illuminato a LED blu 12V Inner border with blue LED 12V |



AISI 316 NEW

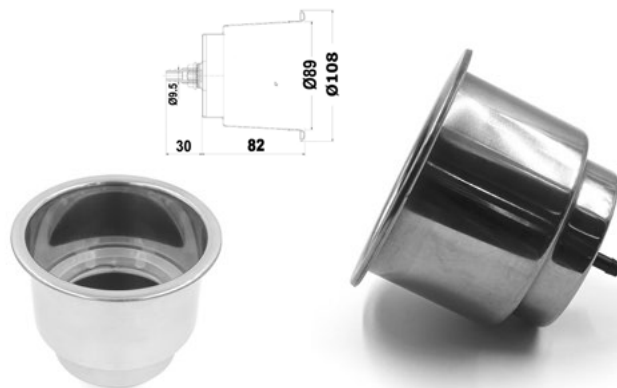

Portabicchieri

Glass holder

Realizzato in acciaio inox Aisi 316 lucidato a specchio.

Manufactured in mirror polished Aisi 316 stainless steel.

| Articolo - Item | €/pc. | Anelli Rings | Ø interno inner mm. | Dim. esterna Outer size mm. | Ø Prigionieri Studs mm. |
|-----------------|-------|--------------|---------------------|-----------------------------|-------------------------|
| D 17 15 001 | | 1 | 92 | Ø 110 | 5 |
| D 17 15 002 | | 2 | 92 | 200x110 | 5 |



AISI 316 NEW



Portabicchiere per draglie «Swinger»

Glass and can holder for rail «Swinger»

Fabbricato in acciaio inox. Indicato per fissaggio sul cavo della draglia. Modello universale.

Manufactured in stainless steel. Universal model.

| Articolo - Item | €/pc. | kg. |
|-----------------|-------|-------|
| D 17 00 163 | | 0,160 |



Supporto bicchieri e lattine a ribalta

Folding glass & can holder ribalta

In plastica bianca.

Manufactured in white plastic.

| Articolo - Item | €/pc. | Colore-Colour | kg. |
|-----------------|-------|---------------|-------|
| D 17 74 004 | | Bianco-White | 0,110 |



Porta cima o anulare

Line holder

In acciaio inox Aisi 304.

Manufactured in Aisi 304 stainless steel.

| Articolo - Item | €/pc. | mm. | kg. |
|-----------------|-------|--------|-------|
| N 17 85 140 | | 85x140 | 0,090 |



Portabicchieri/Tazze/Binocoli

In polietilene bianco inalterabile.

Glass & mug holder

Manufactured in white permanent polyethylene.

| Articolo - Item | €/pc. | N. Tazze-Cups | ↑ mm. | H mm. | Ø Bicchieri Glasses mm. | Fissaggio Fastening |
|-----------------|-------|------------------------|---------|-------|-------------------------|------------------------------|
| D 17 85 815 | | 1 | 115x120 | 85 | 85 | 4 Viti-Screws/Ventosa-Sucker |
| D 17 85 115 | | 2 | 215x120 | 85 | 90 | 4 Viti a parete-Wall screws |
| D 17 85 315 | | 2/1 Binocolo-Binocular | 215x120 | 85 | 90/Binocular 195 | 4 Viti a parete-Wall screws |

NEW



D1785815



D1785115



D1785315

Portabicchiere a ventosa

Fabbricato in materia plastica con fondo a ventosa. Indicato anche come portabottiglie e portamatite.

Suction-type glass-holder

Manufactured in plastic material.

| Articolo - Item | €/pc. | €/box | Colore-Colour | Mod. |
|-----------------|-------|-------|---|-------------------------|
| D 17 00 074 | | | <input type="checkbox"/> Bianco - White | Antisdrucciolo-Non slip |

6 made by



Portabicchiere universale

In plastica. Da installare a scatto su pulpiti o battaglie.

Glass holder

Manufactured in plastic. Suitable for mounting on pulpits or handrails.

| Articolo - Item | €/Kit | Versione Version | Per tubi-For pipes Ø mm. | Kit pcs. |
|-----------------|-------|----------------------|--------------------------|----------|
| D 17 45 030 | | Universale-Universal | 25/30 | 3 |

NEW



Clip per fissaggio oggetti vari

In nylon bianco. Molla Aisi 316. Fissaggio a parete tramite vite, oppure a scatto al pulpito. Per tubi Ø 22-25 mm.). Utile per appendere i vestiti ad asciugare o appendere cavi elettrici.

Fixing clip

Made of white nylon. Stainless steel spring. It can be fixed to a bulkhead by a screw, or snap-hooked to the pulpit (for pipes Ø 22/25 mm). Suitable to hang clothes to dry, ropes, electric cables and any other object.

| Articolo - Item | €/Kit | Kit pcs. |
|-----------------|-------|----------|
| D 17 22 025 | | 4 |

NEW



Contenitore pieghevole porta scarpe

Folding rack for shoes

Studiato appositamente per riporre le scarpe in maniera funzionale.
Realizzato in materiale impermeabile.
Facilmente appendibile a porte o pareti.

Specifically designed to store shoes or ropes.
Manufactured in waterproof material.
Very easy to put on doors or wall.

| Articolo - Item | €/pc. | mm. | kg. |
|-----------------|-------|------------|-------|
| D 10 84 054 | | 840x540x20 | 1,000 |



Contenitore pieghevole per bagno

Folding bag for bathroom

Studiato per essere appeso in spazi ridotti e fungere da armadietto a ripiani.
Chiuso svolge la funzione di una normale trousses.
Realizzato in materiale impermeabile.

Specifically designed to be hanged in small rooms or to serve as a wardrobe.
Manufactured in waterproof material.

| Articolo - Item | €/pc. | mm. | kg. |
|-----------------|-------|---|-------|
| D 10 30 037 | | Aperto-Open: 300x1180x110 Chiuso-Closed: 300x370x110 | 0,500 |



Portaoggetti verticale triplo aggancio

Vertical object holder

| Articolo - Item | €/pc. | mm. | kg. |
|-----------------|-------|-----------|-------|
| D 10 11 084 | | 470Lx800H | 0,500 |



Portaoggetti orizzontale triplo aggancio

Horizontal object holder

| Articolo - Item | €/pc. | mm. | Tasche Pockets | kg. |
|-----------------|-------|-----------|----------------|-------|
| D 10 06 039 | | 870Lx380H | 6 | 0,500 |



SHARK

La nuova gamma di zaini **SHARK** combina design e tecnologia nei materiali, per dare vita alla prima linea di prodotti subacquei sul mercato che sposano le esigenze degli appassionati di diving e di tutti gli amanti dello snorkeling. La scelta ideale per tutti coloro che hanno l'esigenza di **mettere in sicurezza** ogni tipo di oggetto in barca o in acqua.



CONTENITORI-TASCHE-RETI-SACCHE | POCKETS-BAGS-ELASTIC NETS

SACCHE E ZAINI STAGNI «SHARK» | WATERTIGHT BACKPACKS & BAGS

21

Sacca stagna Mini «Shark»

Fabbricata in PVC. Ideale per piccoli oggetti.

Watertight bag Mini «Shark»

Manufactured in PVC. Suitable for small objects.

| Articolo - Item | €/pc. | mm. | Lt. | Colore-Colour |
|-----------------|-------|---------|-----|--|
| B 07 02 290 | | 110x290 | 2 | Arancio/Trasparente-Orange/Transparent |

 **WATERPROOF**  **NEW** made by 



Zaino stagno «Shark»

Fabbricato in PVC. Cinghie in poliestere.
Provvisto di tasca water resistant frontale, doppie tasche laterali in rete.

Watertight backpack «Shark»

Manufactured in PVC. Polyester belts.
Equipped with water resistant pocket, double sided net pockets.

| Articolo - Item | €/pc. | mm. | Lt. | Colore-Colour |
|-----------------|-------|-------------|-----|---------------|
| B 07 79 042 | | 630x350x180 | 42 | Grigio-Grey |

 **WATERPROOF**  **NEW** made by 



Borsone stagno «Shark»

Fabbricato in Nylon 420D con doppia spalmatura in TPU.
Tasca interna impermeabile. Provvisto di spallaccio e maniglie laterali.

Watertight bag «Shark»

Manufactured in Nylon 420D with double TPU coating.
Internal watertight pocket. Equipped with strap and carry handles.

| Articolo - Item | €/pc. | mm. | Lt. | Colore-Colour |
|-----------------|-------|---------|-----|---------------|
| B 07 79 201 | | 620x490 | 60 | Grigio-Grey |

 **WATERPROOF**  **NEW** made by 



CONTENITORI-TASCHE-RETI-SACCHE | POCKETS-BAGS-ELASTIC NETS

Zaino stagno «Shark»

Fabbricato in Nylon 420D con doppia spalmatura in TPU. Ideale come zaino da lavoro, avendo una tasca interna con cerniera stagna, due tasche a rete laterali e un vano interno dove riporre il PC. Schienale imbottito con tessuto traspirante.

Watertight backpack «Shark»

Manufactured in Nylon 420D with double TPU coating. Internal pocket with watertight hinge. Double sided net pockets and interior compartment for laptop storage. Padded backrest with breathable fabric.

| Articolo - Item | €/pc. | mm. | Lt. | Colore-Colour |
|-----------------|-------|-------------|-----|------------------------|
| B 07 79 038 | | 630x320x180 | 38 | Grigio scuro-Dark grey |



Zaino stagno gonfiabile «Shark»

Fabbricato in Nylon 190T con spalmatura 0,35 mm. in PVC. Grazie alla particolarità di potere essere gonfiabile e grazie a spallacci e cinghie, può essere utilizzato come un normale zaino. Oppure, all'interno, si possono riporre teli e infradito. Inoltre, è possibile legarselo in vita e utilizzarlo come pallone di segnalazione durante lo snorkeling e le immersioni.

Inflatable watertight backpack «Shark»

Manufactured in Nylon 190T with PVC 0,35 mm. coating. It can be used as a normal backpack or as a signalling buoy when diving or snorkeling.

| Articolo - Item | €/pc. | mm. | Lt. | Colore-Colour |
|-----------------|-------|---------|-----|------------------------|
| B 07 70 028 | | 720x360 | 28 | Arancio segnale-Orange |

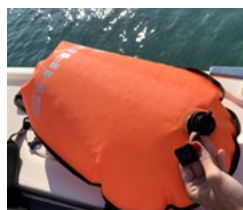

FISCHIO DI SEGNALAZIONE WHISTLE

GONFIABILE INFLATABLE



PORTATA-CAPACITY 28 LT.

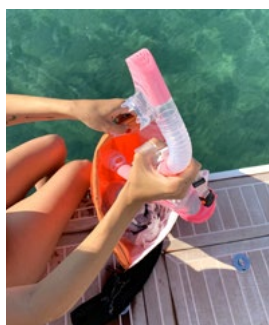

SUBACQUEO FINO A 5 MT. UNDERWATER UP TO 5 MT.

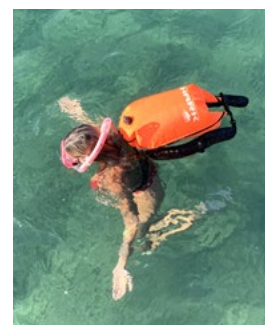

PALLONE DI SEGNALAZIONE SIGNALLING BALL



Sacche impermeabili

Complete di cinghia spallaccio.

Waterproof bags

Supplied with belt.

| Articolo - Item | €/pc. | Colore-Colour | Materiale-Material | Lt. | ↑ mm. | kg. |
|-----------------|-------|---------------|--------------------|-----|-----------|-------|
| B 07 79 018 | | Grigio-Grey | 0,38 mm. 250D PVC | 18 | 56 x Ø 20 | 0,100 |
| B 07 79 028 | | Grigio-Grey | 0,38 mm. 250D PVC | 28 | 58 x Ø 25 | 0,130 |
| B 07 79 037 | | Grigio-Grey | 0,38 mm. 250D PVC | 37 | 60 x Ø 28 | 0,200 |
| B 07 79 046 | | Grigio-Grey | 0,38 mm. 250D PVC | 46 | 69 x Ø 29 | 0,580 |



SACCHE | BAGS



Sacche impermeabili

Fabbricato in PVC.

Waterproof bags

Made of PVC material.

| Articolo - Item | €/pc. | Mod. | Colore Colour | Lt. | ↑ mm. | kg. |
|-----------------|-------|--------------------------|---------------|-----|-----------|-------|
| B 06 20 009 | | senza cinghia-w/out belt | Yellow | 18 | 52 x Ø 20 | 0,160 |
| B 06 40 010 | | senza cinghia-w/out belt | Yellow | 37 | 55 x Ø 29 | 0,250 |
| B 06 60 011 | | senza cinghia-w/out belt | Yellow | 46 | 68 x Ø 29 | 0,530 |



Sacche impermeabili

Fabbricato in nylon 420D TPU, provvisto di cinghia spallaccio

Waterproof bags

Supplied with shoulder belt. Made of nylon 420D TPU material.

| Articolo - Item | €/pc. | Mod. | Colore Colour | Lt. | ↑ mm. | kg. |
|-----------------|-------|--------------------------|---------------|-----|-----------|-------|
| B 07 79 011 | | senza cinghia-w/out belt | Grey | 46 | 68 x Ø 29 | 0,580 |
| B 07 79 108 | | con spallaccio-with belt | Grey | 5 | 44 x Ø 12 | 0,100 |
| B 07 79 109 | | con spallaccio-with belt | Grey | 18 | 52 x Ø 20 | 0,130 |
| B 07 79 110 | | con spallaccio-with belt | Grey | 37 | 55 x Ø 29 | 0,200 |



Sacco per vele mod. «Sail»

Fabbricato in tessuto di cotone spalmato in PVC.

Boat bag mod. «Sail»

Supplied with snap-link. Made of water-proof material.

| Articolo - Item | €/pc. | ↑ mm. | Mod. |
|-----------------|-------|-----------|------|
| B 05 60 110 | | 600x1000H | SAIL |



Busta portadocumenti galleggiante

Fabbricata in tessuto nylon impermeabile ed antistrappo. Rivestita internamente di materiale galleggiante.

Floating docs holding envelope

Manufactured in water-proof nylon cloth and lined inside with floating material.

| Articolo - Item | €/pc. | ↕ cm. |
|-----------------|-------|-------|
| D 10 25 030 | | 25x28 |



Porta documenti impermeabile «Trasparente»

Fabbricato in plastica con chiusura impermeabile.

Sea document holder «Trasparente»

Manufactured in plastic. With waterproof latch.

| Articolo - Item | €/pc. | ↕ cm. |
|-----------------|-------|-------|
| D 10 34 025 | | 34x25 |



Porta documenti con decoro marino

Fabbricata in plastica con chiusura impermeabile.

Sea document holder

Manufactured in plastic. With waterproof latch.

| Articolo - Item | €/pc. | ↕ cm. |
|-----------------|-------|-------|
| D 10 26 020 | | 26x20 |



Busta porta documenti

Fabbricata in plastica con chiusura impermeabile. Galleggiante e impermeabile.

Documents holding envelope

Manufactured in plastic. With waterproof latch. Floating and waterproof.

| Articolo - Item | €/pc. | ↕ cm. |
|-----------------|-------|-------|
| D 10 01 028 | | 20x26 |



Tasca impermeabile

Realizzata in materiale impermeabile, ideale come portadocumenti o portaoggetti. Provvista di bottoni da montare sugli sportelli 600x355 e 463x517.

Waterproof bag

Suitable to be used as document holder for nautics. Provided with buttons to be fitted on access hatches 600x355 and 463x517.

| Articolo - Item | €/pc. | Mod. | ↕ cm. |
|-----------------|-------|----------------|----------|
| D 10 75 355 | | Cerniera-Hinge | Blu-Blue |



Contentore waterproof per iPad

| Articolo - Item | €/pc. | ↕ mm. | Colore-Colour | kg. |
|-----------------|-------|-----------|---------------------------------------|-------|
| D 10 82 805 | | 4x210x290 | <input type="checkbox"/> Bianco-White | 0,110 |



Contentore waterproof per iPhone

| Articolo - Item | €/pc. | ↕ mm. | Colore-Colour | kg. |
|-----------------|-------|----------|--|-------|
| D 10 82 803 | | 3x85x170 | <input checked="" type="checkbox"/> Blu-Blue | 0,040 |



Contentore waterproof per iPhone Plus

| Articolo - Item | €/pc. | ↕ mm. | Colore-Colour | kg. |
|-----------------|-------|-----------|--|-------|
| D 10 82 807 | | 3x120x180 | <input checked="" type="checkbox"/> Blu-Blue | 0,050 |



Tasca portaoggetti e portacime

Fabbricata in tessuto plastificato a rete.
Completa di bottoni automatici per il fissaggio a parete.

| Articolo - Item | €/pc. | Attacco Fitting | ↕ mm. |
|-----------------|-------|------------------|-------------|
| D 10 40 030 | | Parete-Wall | 300x400x150 |
| D 10 25 036 | | Battagliola-Rail | 250x350x120 |



D1040030

Stowage bag for ropes

Manufactured in plastified cloth.
To stow ropes in the cockpit for wall mounting.



D1025036

Tasche portaoggetti e portacime

Fabbricate in tessuto plastificato a rete complete di bottoni per il fissaggio.

| Articolo - Item | €/pc. | ↕ mm. |
|-----------------|-------|-------------|
| D 10 15 035 | | 350x250x150 |
| D 10 15 045 | | 450x300x150 |



Stowage bag for ropes

Manufactured in plastified cloth.
To stow ropes in the cockpit.

Valigetta per impiombature

Valigetta in nylon 36x30x6 cm.

Splicing bag

Nylon case 36x30x6 cm.

| Articolo - Item | €/pc. | Mod. |
|-----------------|-------|----------------------------|
| D 10 30 036 | | Valigetta vuota-Empty case |



Tasca porta oggetti per battagliola

Fabbricata in tessuto impermeabile, chiusura con bottoni inox e velcro.

| Articolo - Item | €/pc. | ↕ mm. |
|-----------------|-------|--------|
| D 10 08 020 | | 300x80 |



Case for small objects to be applied to the guardrail

Manufactured in waterproof fabric, closing with stainless steel buttons and Velcro.

Tasca porta oggetti per battagliola

Fabbricata in tessuto a rete completa di attacco a battagliola con velcro. Provvista di doppia tasca, con tasca frontale completa di chiusura.

| Articolo - Item | €/pc. | ↕ mm. |
|-----------------|-------|---------|
| D 10 40 050 | | 500x400 |



Case for small objects to be applied to the guardrail

Manufactured in plastified mesh fabric. With double pocket and frontal Velcro pocket.

AERATORI | VENTILATORS

Aeratore «Sunvent»

Funzionamento ad energia solare.
Completo di guarnizione per l'applicazione.

Ventilator «Sunvent»

Solar power operation.
Complete with application gasket.

| Articolo - Item | €/pc. | Incasso-Hole Ø mm. | Ø esterno Outer mm. | kg. |
|-----------------|-------|-----------------------|------------------------|-------|
| L 64 01 220 | | 115 | 220 | 0,440 |

**Aeratore**

Fabbricato in acciaio inox.
Consente il passaggio dell'aria in cabina.

Ventilator

Manufactured in stainless steel.
Allows the change of air in the cabin.

| Articolo - Item | €/pc. | Ø esterno Outer mm. | Ø interno inner mm. | H mm. | kg. |
|-----------------|-------|------------------------|------------------------|-------|-------|
| Z 22 11 230 | | 230 | 85 | 40 | 0,330 |

**Aeratore**

Fabbricato in acciaio inox Aisi 316.

Ventilator

Manufactured in Aisi 316 S.S.

| Articolo - Item | €/pc. | Ø esterno Outer mm. | Incasso-Hole Ø mm. | Sporgenza Overgang mm. | H mm. | kg. |
|-----------------|-------|------------------------|-----------------------|---------------------------|-------|-------|
| L 64 70 225 | | 217 | 119 | 31 | 71 | 0,330 |

**Aeratore**

Copertura in acciaio inox con base in plastica.

Ventilator

S.S. cover with plastic base.

| Articolo - Item | €/pc. | Ø mm. | kg. |
|-----------------|-------|-------|-------|
| L 64 00 193 | | 193,7 | 0,450 |



PRESE D'ARIA | AIR VENTILATORS

Presse d'aria

Fabbricata in nylon bianco.

Air ventilator

Manufactured in white nylon.

| Articolo - Item | €/pc. | mm. |
|-----------------|-------|--------|
| Z 22 79 140 | | 140x80 |

 **NEW**
**Presse d'aria**

Fabbricata in nylon bianco.

Air ventilator

Manufactured in white nylon.

| Articolo - Item | €/pc. | mm. |
|-----------------|-------|---------|
| Z 22 14 126 | | 140x126 |

 **NEW**
**Presse d'aria**

Fabbricata in nylon bianco.

Air ventilator

Manufactured in white nylon.

| Articolo - Item | €/pc. | mm. |
|-----------------|-------|---------|
| Z 22 26 125 | | 260x125 |

 **NEW**
**Presse d'aria**Fabbricata in acciaio inox lucidato.
Ideale per cabine e vani motore.**Air ventilator**Manufactured in polished stainless steel.
Suitable for cabins and engine rooms.

| Articolo - Item | €/pc. | mm. | kg. |
|-----------------|-------|---------|-------|
| Z 22 12 115 | | 127x115 | 0,120 |
| Z 22 04 003 | | 115x230 | 0,160 |

 **AISI 316**

Z2212115

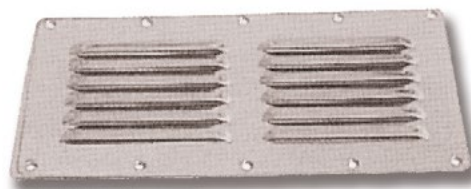

Z2204003

Presse d'aria

Fabbricata in acciaio inox.

Air ventilator

Manufactured in stainless steel.

| Articolo - Item | €/pc. | Ø mm. | kg. |
|-----------------|-------|---------|-------|
| Z 22 23 026 | | 130/120 | 0,070 |

 **AISI 316**
**Presse d'aria**

Fabbricata in acciaio inox Aisi 316/304.

Air ventilator

Manufactured in Aisi 316/304 stainless steel.

| Articolo - Item | €/pc. | Ø mm. | kg. |
|-----------------|-------|-------|-------|
| Z 22 23 028 | | 125 | 0,100 |

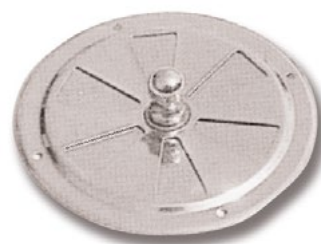
 **AISI 316**

Prese d'aria quadrate

Square air vents

| Articolo - Item | €/pc. | €/box | Colore-Colour | Passaggio aria-Air vent mm ² | ↑ mm. | 📦 pcs. |
|-----------------|-------|-------|---------------|---|---------|--------|
| Z 22 33 118 | | | Crema-Cream | 5000 | 118x118 | 5 |
| Z 22 74 118 | | | Bianco-White | 5000 | 118x118 | 5 |
| Z 22 79 118 | | | Grigio-Grey | 5000 | 118x118 | 5 |
| Z 22 80 118 | | | Nero-Black | 5000 | 118x118 | 5 |

madeby 



Prese d'aria rettangolari

Rectangular air vents

| Articolo - Item | €/pc. | €/box | Colore-Colour | Passaggio aria-Air vent mm ² | ↑ mm. | 📦 pcs. |
|-----------------|-------|-------|---------------|---|---------|--------|
| Z 22 33 206 | | | Crema-Cream | 8000 | 206x106 | 5 |
| Z 22 74 206 | | | Bianco-White | 8000 | 206x106 | 5 |
| Z 22 79 206 | | | Grigio-Grey | 8000 | 206x106 | 5 |
| Z 22 80 206 | | | Nero-Black | 8000 | 206x106 | 5 |

madeby 



SENSORE GAS SALVAVITA | GAS DETECTOR

Circuito a Microprocessore Taratura Automatica
Elevata sensibilità

Sensibile rilevatore per tutti i gas nocivi (GPL - monossidi di carbonio - gas soporiferi). Rileva tempestivamente la presenza di gas nell'ambiente, avvisando con un forte segnale acustico.
Il dispositivo viene fornito completo di cavo con spinotto universale a 12V. per un utilizzo senza installazione. Possibilità di fissaggio a parete.
In conformità alla normativa 89/336/EEC - 93/68/EEC.

Microprocessor Circuit Automatic Calibration
High sensibility

Gas detector with chip sensitive to all gases (LPG, carbon monoxide, gas soporific). Equipped with acoustic buzzer in case of alarm, a lock out solenoid valve and an LED indicator status.
Compliant legislation 89/336/EEC - 93/68/ EEC.

| Articolo - Item | €/pc. | ↑ Base mm. | Tensione Voltage V. DC | Consumo modalità Stand-by Consumption in Stand-by mode mA | Consumo modalità Allarme Consumption in Alarm mode mA | Segnale acustico Acoustic signal db | Sensibilità Sensitivity ppmEEC |
|-----------------|-------|------------|------------------------|---|---|-------------------------------------|--------------------------------|
| L 23 95 057 | | 85x43 | 5-14 | 60 | 180 | 85 | 95 |

 **12V IL NASO ELETTRONICO PER UNA SOSTA TRANQUILLA**
THE ELECTRONIC NOSE FOR A QUIET STOP



Ventilatore oscillante

Velocità regolabile 100-300m/min.
Fusibili 2A.
Griglia di protezione in plastica.
Installazione al piano/al soffitto/a parete.

Oscillating fan

Micro adjusted speed control 100-300m/min.
Fuse size 2A.
Plastic fan guard.
Can be installed by surface mount/ceiling mount/wall mount.

| Articolo - Item | €/pc. | Volts | Amp. | kg. |
|-----------------|-------|--------|------|--------|
| L 64 12 910 | | 12 VDC | 1,2 | 14,700 |

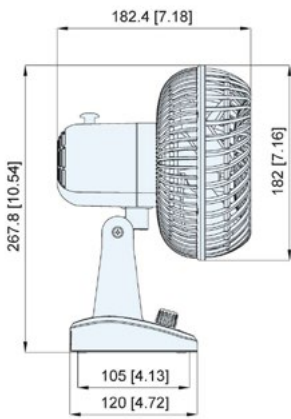

Ventilatore 12V

Orientabile con cavo e presa accendisigari.

Ventilator 12V

Swinging model.
With cable and cigarette lighter plug.

| Articolo - Item | €/pc. | cavo-cable mt. | Ø esterno-outer mm. | kg. |
|-----------------|-------|----------------|---------------------|-------|
| L 64 00 601 | | 1 | 145 | 0,380 |



Ventilatore a parete 12V

Orientabile con cavo e presa accendisigari.
A due velocità.

Wall ventilator 12V

Swinging model. With cable and cigarette lighter plug. Double speed.

| Articolo - Item | €/pc. | cavo-cable mt. | Ø esterno-outer mm. | kg. |
|-----------------|-------|----------------|---------------------|-------|
| L 64 12 063 | | 1,600 | 150 | 0,310 |



Ventilatore 12V

Orientabile in tutte le posizioni.
Portata 1000 m3/h.

Ventilator 12V

Swinging model.
Load 1000 m3/h.

| Articolo - Item | €/pc. | Ø esterno-outer mm. | kg. |
|-----------------|-------|---------------------|-------|
| L 64 12 062 | | 180 | 0,570 |



Elettroaspiratori 12V in linea

In-line blowers 12V

Conformi alla normativa USCG 183,410.

USCG 183,410 compliant.

| Articolo - Item | €/pc. | Amp. | A mm. | B mm. | C hole mm. | Resa-Output mt ³ /min. | kg. |
|-----------------|-------|------|-------|-------|------------|-----------------------------------|-------|
| P 16 11 604 | | 2,9 | 77 | 132 | 120 | 3800 | 0,450 |



SUGGESTED ITEM



TUBO AIR
art. P16 06 075
(pag. 383)

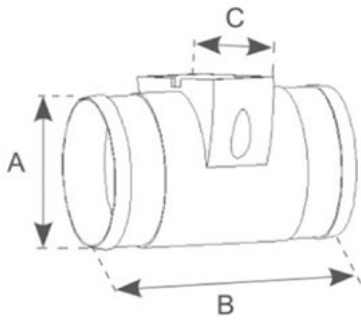

Elettroaspiratori 12V in linea

In-line blowers 12V

Perfettamente stagni.
Cassa in ABS.

Waterproof.
ABS housing.

| Articolo - Item | €/pc. | Mod. | Amp. | A mm. | B mm. | C hole mm. | Resa-Output mt ³ /min. | kg. |
|-----------------|-------|------|------|-------|-------|------------|-----------------------------------|-------|
| P 16 27 075 | | A | 1,5 | 77 | 127 | 112 | 3000 | 0,370 |
| P 16 10 105 | | B | 6 | 102 | 204 | 127 | 6500 | 0,900 |



SUGGESTED ITEM



TUBO AIR
art. P16 06 075-P16 06 100
(pag. 383)

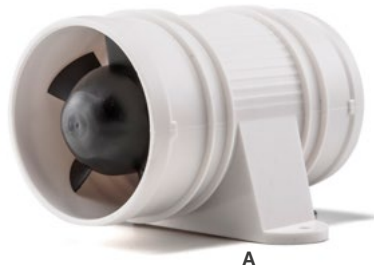
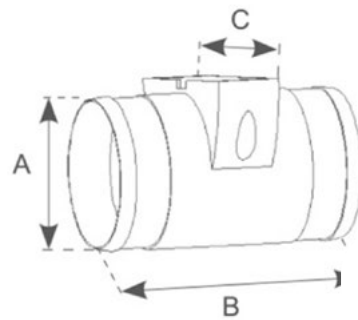

Aspiratore gas di sentina «Blower» 12V

Bilge gas extractor «Blower» 12V

Motore stagno con separazione ventola.
Completo di griglia e riduzione tubo.

Watertight engine with separate fan,
supplied with drain grid and hose flange.

| Articolo - Item | €/pc. | Volts | Amp. | Portata-Flow rate mc/hour | Ingresso-IN outer Ø mm. | Uscita-OUT inner Ø mm. | kg. |
|-----------------|-------|-------|------|---------------------------|-------------------------|------------------------|-------|
| L 64 12 260 | | 12 | 3,9 | 280 | 75 | 72 | 0,900 |

| H mm. | Profondità Depth mm. | Larghezza Width mm. | A mm. | B mm. | C mm. | D mm. | kg. |
|-------|----------------------|---------------------|-------|-------|-------|-------|-------|
| 200 | 165 | 195 | 82 | 56 | 25 | 65 | 0,900 |



SUGGESTED ITEM



TUBO AIR
art. P16 12 080
(pag. 383)

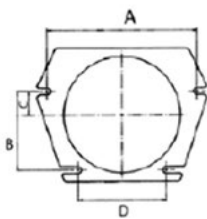
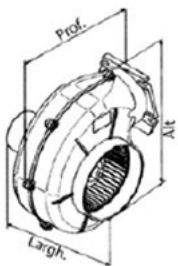

TUBI ASPIRAZIONE | VENTILATION HOSES

Tubo Air (a soffiutto)

Per aspirazione aria.
Armato con spirale in acciaio.

Flexible ventilation hose

For air suction.
Provided with steel spiral.

| Articolo - item | €/mt. | Ø mm. | mt. |
|-----------------|-------|-------|-----|
| P 16 06 075 | | 75 | 12 |
| P 16 06 100 | | 100 | 12 |
| P 16 12 080 | | 80 | 12 |





Tbrite

THE BETTER WAY TO CLEAN

ACCESSORI PER PULIZIA «T-BRITE» | «T-BRITE» CLEANING ACCESSORIES

Spazzolone telescopico con rubinetto

Set pulizia composto da asta in alluminio telescopica e spazzolone con setola morbida. Predisposto per innesto tubo acqua sul manico.

Telescopic boat brush with tap

Hollow anodised aluminium telescopic pole. Brush with soft bristles. With waterfeed possibility.

| Articolo - Item | €/Kit | Ø mm. | Lunghezza-Length cm. | Mod. | kg. |
|-----------------|-------|---------|----------------------|--|-------|
| R 38 02 166 | | 19-22,6 | 100 ≈ 180 | Kit con spazzola setole morbide Kit with soft bristle brush | 1,500 |



Spazzolone telescopico a pulsante con testa in alluminio

Diametro rinforzato. Ideale per barche di grandi dimensioni.

Telescopic boat brush with aluminium head

Reinforced diameter. Suitable for large size leisure boats.

| Articolo - Item | €/Kit | Ø mm. | Lunghezza-Length cm. | Mod. | kg. |
|-----------------|-------|-------|----------------------|---|-------|
| R 38 32 440 | | 32-25 | 140 ≈ 250 | Kit con spazzola a setole morbide con gomma antiurto, attacco alu fuso Kit with soft bristle brush, shock proof rubber, melted alu joint | 1,100 |



ATTACCO RINFORZATO IN ALLUMINIO
ALU REINFORCED CONNECTION



Kit 4 pezzi composto da mezzo marinaio, spazzolone e frattazzo in cotone

Tutti gli elementi sono intercambiabili e facilmente inseribili sul tubo di alluminio telescopico.

Washing kit 4 pieces composed of: boat hook - cotton brush - scrubbing brush - telescopic pole

All items are easily interchangeable and can be fitted onto the telescopic aluminium pole.

| Articolo - Item | €/Kit | Lunghezza-Length cm. | Mod. | kg. |
|-----------------|-------|----------------------|-----------------|-------|
| R 38 03 381 | | 120 ≈ 215 | «Trem-Friend 4» | 3,800 |



CONFEZIONE SELF-SERVICE
SELF-SERVICE PACKING



ACCESSORI PER PULIZIA «T-BRITE» | «T-BRITE» CLEANING ACCESSORIES



ACCESSORI PER PULIZIA «T-BRITE» | «T-BRITE» CLEANING ACCESSORIES

Gancio d'accosto Nylon hook

| Articolo - Item | €/pc. |
|-----------------|-------|
| R 38 04 135 | |



Gancio d'ormeggio Mooring hook

| Articolo - Item | €/pc. |
|-----------------|-------|
| R 38 04 150 | |



Fratteggio di cotone Cotton brush

| Articolo - Item | €/pc. |
|-----------------|-------|
| R 38 04 038 | |



Spazzola di ricambio setole morbide Spare brush soft bristle

| Articolo - Item | €/pc. |
|-----------------|-------|
| R 38 00 166 | |



Spazzola di ricambio a setole morbide con raccogliacqua Soft bristle brush with water-case

| Articolo - Item | €/pc. |
|-----------------|-------|
| R 38 00 400 | |



ACCESSORI PER PULIZIA «T-BRITE» | «T-BRITE» CLEANING ACCESSORIES

Spazzolone «T-BRITE»

Struttura in legno marino verniciato ai poliuretani, bordo antiurto, attacco angolato a scatto in alluminio. Lunghezza 6".

Scrubbing brush «T-BRITE»

Manufactured in polyurethane coated marine wood. Shock-proof rim. Aluminium snap connection. Length 6".

| Articolo - Item | €/pc. | Uso-Use | Tipo-Type | mm. | Materiale-Material | Colore-Colour |
|-----------------|-------|------------------------------------|-------------------------------|------------|--------------------|----------------|
| R 38 07 068 | | Macchie difficili-Difficult stains | Duro-Stiff | 240x155x85 | Polyester | Bianco-White |
| R 38 05 068 | | Pulizia varia-Generic cleaning | Media durezza-Medium hardness | 240x155x85 | Polyester | Arancio-Orange |
| R 38 02 068 | | Insaponatura-Soaping | Morbido-Soft | 240x155x85 | Polyester | Giallo-Yellow |
| R 38 06 068 | | Vetri/Polvere-Glasses/Powder | Extra morbido-Extra soft | 240x155x85 | Nylon | Blu-Blue |



COMPLETO DI-COMplete WITH



MOLLETTA - SPRING
(pag. 391)

SUGGESTED ITEM

MANICI-HANDLES
(pag. 386)



R3806068

IDEALE PER VETRI E PLEXIGLASS. NON USARE PRODOTTI A BASE ACIDA O ALCOLICA.

SUITABLE FOR GLASSES OR PLEXIGLASS. DO NOT USE PRODUCTS ACID OR ALCOHOLIC BASED.



R3802068

IDEALE PER TUTTI GLI USI. CONSIGLIATO PER INSAPONARE.

SUITABLE FOR ANY USE. RECOMMENDED FOR SOAPING.



R3805068

PER PULIRE TEAK, CUSCINI O TELA. NON USARE SU VERNICI O VETRI. RESISTE AI PRODOTTI CHIMICI.

SUITABLE FOR CLEANING TEAK, CUSHIONS OR CANVAS. DO NOT USE ON PAINTS OR GLASSES. CHEMICALS RESISTANT.



R3807068

PER PULIRE PONTI IN TEAK O VETRORESINA. RIMUOVE MACCHIE RESISTENTI. NON USARE SU VERNICI O VETRI. RESISTE AI PRODOTTI CHIMICI.

SUITABLE FOR CLEANING TEAK OR FIBREGLASS DECKS. CAN REMOVE RESISTANT STAINS. DO NOT USE ON PAINTS OR GLASSES. CHEMICALS RESISTANT.



Manico telescopico per spazzoloni

In alluminio brillantato, fisso o telescopico per raggiungere i punti più lontani. Dotato di sistema di bloccaggio a scatto in acciaio inox e di due comode impugnature antiscivolo.

Telescopic pole for brushes

Manufactured in polished aluminum. Steady or telescopic to clean any difficult point. Locking system in stainless steel. Double anti-slip grips.

| Articolo - Item | €/pc. | Ø mm. | Lunghezza-Length cm. | Mod. | pcs. |
|-----------------|-------|---------|----------------------|---------------------------------------|------|
| R 38 00 072 | | 19-22,6 | 100 ≈ 180 | Manico in alluminio-Alluminium handle | 12 |
| R 38 00 274 | | 19-22,6 | 160 ≈ 274 | Manico in alluminio-Alluminium handle | 12 |



ACCESSORI PER PULIZIA «T-BRITE» | «T-BRITE» CLEANING ACCESSORIES

Adattatore angolato

Fabbricato in alluminio anodizzato, angolato a 35° per riuscire ad arrivare anche nei posti più difficili come le murate. Dotato di sistema di bloccaggio a scatto.

Angled adapter

Manufactured in anodised aluminium, 35° angled to be able to reach even the most difficult places. Equipped with snap locking system.

| Articolo - Item | €/pc. | Lunghezza-Length cm. |
|-----------------|-------|----------------------|
| R 38 20 031 | | 25 |



COMPLETO DI-COMLETE WITH



MOLLETTA - SPRING
(pag. 391)

SUGGESTED ITEM

MANICI-HANDLES
(pag. 386)

Gancio di accosto

Fabbricato in alluminio anodizzato. Montaggio a scatto.

Boat hook

Manufactured in anodised aluminium. Snap mounting system.

| Articolo - Item | €/pc. | Lunghezza-Length cm. |
|-----------------|-------|----------------------|
| R 38 25 250 | | 15 |



COMPLETO DI-COMLETE WITH



MOLLETTA - SPRING
(pag. 391)

SUGGESTED ITEM

MANICI-HANDLES
(pag. 386)

Guadino da pesca

Fabbricato in acciaio inox. Montaggio a scatto. Maglia fina.

Landing net

Manufactured in stainless steel. Snap mounting system. Fine sweater.

| Articolo - Item | €/pc. | mm. |
|-----------------|-------|-------------|
| R 38 20 000 | | 400x650x750 |



COMPLETO DI-COMLETE WITH



MOLLETTA - SPRING
(pag. 391)

SUGGESTED ITEM

MANICI-HANDLES
(pag. 386)

Mocio in PVA

Con strisce extra assorbenti larghe 70 mm. Innesto rapido a scatto. Soffice ed elastico, è resistente agli oli, ai grassi ed ai prodotti chimici. Ideale per il lavaggio di ponti e superfici verniciate.

PVA mop

With extra absorbent strips 70 mm. wide. Quick snap coupling. Soft and elastic, oil, grease and chemical resistant. Suitable for painted deck cleaning.

| Articolo - Item | €/pc. | Lunghezza-Length mm. | Larghezza pelli-Bristle width mm. |
|-----------------|-------|----------------------|-----------------------------------|
| R 38 00 078 | | 400 | 40 |



COMPLETO DI-COMLETE WITH



MOLLETTA - SPRING
(pag. 391)

SUGGESTED ITEM

MANICI-HANDLES
(pag. 386)

ACCESSORI PER PULIZIA «T-BRITE» | «T-BRITE» CLEANING ACCESSORIES

Spazzola a mano

A setole dure con comoda impugnatura. Ideale per pulizia linee di galleggiamento, eliche, ponti in teak, teloni, pulpiti inox. Provvista di paracolpi.

Hand brush

Stiff bristle with comfortable handle. Suitable for cleaning of teak decks, propellers, water lines, tarpaulins and stainless steel pulpits. With buffer.

| Articolo - Item | €/pc. | kg. |
|-----------------|-------|-------|
| N 58 00 131 | | 0,290 |



Spazzola abrasiva per la pulizia della carena

Spazzola con impugnatura. Ideale per togliere le incrostazioni dalla carena dell'imbarcazione.

Boat brush for hull cleaning

Suitable for boat cleaning. Suitable for removing marine fouling from the hull of the boat.

| Articolo - Item | €/pc. | Colore Colour | mm. | Mod. | kg. |
|-----------------|-------|---------------|--------|--------------|-------|
| N 58 90 150 | | Nero-Black | 150x90 | Duro-Stiff | 0,050 |
| N 58 90 152 | | Bianco-White | 150x90 | Morbido-Soft | 0,050 |



Rasiera lavavetri

Fabbricato in silicone. La lama flessibile permette di seguire anche le superfici curve.

Water and window wiper

Manufactured in silicone. The flexible blade allows to follow even the curved surfaces.

| Articolo - Item | €/pc. | Descrizione-Description | kg. |
|-----------------|-------|---|-------|
| N 58 00 211 | | Lama flessibile 300 mm. regolabile a 180° Flexible blade 300 mm. adjustable 180° | 0,290 |



Spugna

Ad altissimo assorbimento e a lunga durata.

Sponge

High absorption sponge, huge resistance.

| Articolo - Item | €/pc. | Abrasione Abrasion | Colore Colour | mm. | kg. |
|-----------------|-------|--------------------|---------------|-------------|-------|
| N 58 80 210 | | Leggera-Light | Giallo-Yellow | 210x110x80H | 0,160 |



Cuscinetto abrasivo

Abrasive cleaning pad

| Articolo - Item | €/pc. | Abrasione-Abrasion | Colore-Colour | mm. | Ideale per-Suitable for |
|-----------------|-------|--------------------|---------------|---------|---|
| N 58 74 250 | | Leggera-Light | Bianco-White | 120x250 | Pulizia generica-Generic cleaning |
| N 58 86 250 | | Forte-Strong | Marrone-Brown | 120x250 | Ruggine/Denti di cane/Vernici-Rust/Paints |



NEW



ACCESSORI PER PULIZIA «T-BRITE» | «T-BRITE» CLEANING ACCESSORIES
Panno pulizia in PVA

Soffice ed elastico, è resistente agli oli, ai grassi ed ai prodotti chimici. Il contenitore lo mantiene utile per utilizzi futuri.

| Articolo - Item | €/pc. | cm. | Colore-Colour | kg. |
|-----------------|-------|-------|-------------------------|-------|
| N 58 00 066 | | 66x43 | Giallo-Yellow | 0,160 |
| N 58 89 066 | | 66x43 | Rosa-Pink | 0,160 |
| N 58 85 066 | | 66x43 | Verde acqua-Light green | 0,160 |
| N 58 75 066 | | 66x43 | Azzurro-Light blue | 0,160 |

PVA cleaning cloth

Soft and elastic, oil, grease and chemical resistant. The transparent box keeps it useful for any future use.



Guanto in microfibra

Fabbricato con centinaia di morbide microfibre. Ideale per pulire grandi superfici in poco tempo.

Microfibre cloth

Mde with hundreds of soft microfibres. Ideal for cleaning big surfaces in short time.

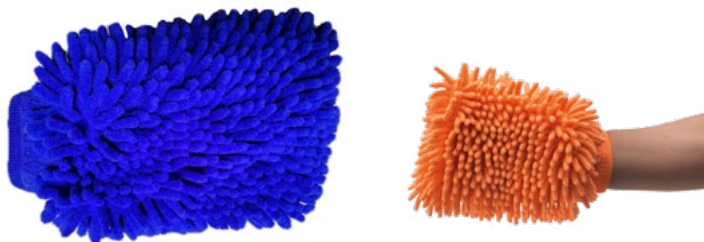
| Articolo - Item | €/pc. | Colore-Colour | kg. |
|-----------------|-------|---------------|-------|
| R 38 20 066 | | Blue | 0,130 |

Kit pulizia in sacca con tracolla «T-BRITE»

Kit composto da:

- Tubo R3800072
- Spazzole R3802068-R3805068
- Adattatore R3820031
- Gancio R3825250
- Frattazzo R3800078
- Spazzola N5800131
- Spazzole carena N5890150-N5890152
- Tira acqua N5800211
- Secchio pieghevole P0024225
- Panno N5800066

Cleaning Set in bag with shoulder belt «T-BRITE»

Kit with:

- Pole R3800072
- Brushes R3802068-R3805068
- Adaptor R3820031
- Hook R3825250
- Mop R3800078
- Brush N5800131
- Brushes for hull cleaning N5890150-N5890152
- Water wiper N5800211
- Folding bucket P0024225
- Cleaning cloth N5800066

| Articolo - Item | €/kit | cm. | kg. |
|-----------------|-------|-----------------|-------|
| R 38 25 115 | | 115 x 15 x h.25 | 1,500 |



ACCESSORI PER PULIZIA «T-BRITE» | «T-BRITE» CLEANING ACCESSORIES

Secchio in silicone pieghevole Folding silicon bucket

Maniglia in plastica.

With plastic handle.

| Articolo - Item | €/pc. | Portata Capacity Lt. | Aperto Open mm. | Chiuso Closed mm. | kg. |
|-----------------|-------|----------------------|-----------------|-------------------|-------|
| P 00 32 000 | | 10 | Ø320x240H | Ø320x50H | 0,460 |



Secchio nautico affondante in gomma Submergible rubber nautical bucket

Submergible rubber nautical bucket

Fabbricato in gomma pesante, affonda rapidamente consentendo un veloce riempimento.

| Articolo - Item | €/pc. | Portata Capacity Lt. | mm. | kg. |
|-----------------|-------|----------------------|-----------|-------|
| P 00 10 000 | | 9 | Ø250x250H | 1,500 |



Secchio pieghevole Folding bucket

Folding bucket

Fabbricato in robusto nylon. Maniglia in acciaio inox. Completo di custodia.

Manufactured in nylon. Handle in stainless steel. Supplied with case.

| Articolo - Item | €/pc. | Portata Capacity Lt. | mm. | kg. |
|-----------------|-------|----------------------|-----------|-------|
| P 00 24 225 | | 9 | Ø240x225H | 0,460 |



Secchio nautico Nautical bucket

Nautical bucket

Fabbricato in materiale termoplastico con manico per aggancio cima. Con manici inox a occhio.

Made of strong thermoplastic material with handle for rope hooking. With stainless steel grommet handles.

| Articolo - Item | €/pc. | Portata Capacity Lt. | mm. | kg. |
|-----------------|-------|----------------------|-----------|-------|
| P 00 23 000 | | 6 | Ø230x230H | 0,400 |
| P 00 25 000 | | 9 | Ø250x250H | 0,500 |
| P 00 33 000 | | 12 | Ø280x330H | 0,800 |



Secchio pieghevole rettangolare Rectangular Folding bucket

Fabbricato in silicone. Ideale anche come lavello.

Manufactured in silicone. Suitable to be used as a sink.

| Articolo - Item | €/pc. | Portata Capacity Lt. | Aperto Open mm. | Chiuso Closed mm. | kg. |
|-----------------|-------|----------------------|-----------------|-------------------|-------|
| P 00 15 380 | | 15 | 380x285x170 | 380x285x50 | 0,500 |



NEW



ACCESSORI PER PULIZIA «T-BRITE» | «T-BRITE» CLEANING ACCESSORIES

Kit tubo lavaggio barca

Composto da tubo da mm 12x17 in pvc bianco con rete di rinforzo interna in poliestere, tipo alta pressione resistente fino a 15 BAR + pistola a getto regolabile con innesto a scatto + 3 raccordi a scatto per rubinetto a terra.

Hose kit for boat cleaning

Composed by hose mm 12x17 in white pvc with reinforced internal polyester net, high pressure type, resistant up to 15 BAR + adjustable spray water gun with quick snap connection + 3 fitting connections for flat tap.

| Articolo - Item | €/Kit | mt. |
|-----------------|-------|-----|
| N 01 02 015 | | 15 |
| N 01 25 025 | | 25 |



SUGGESTED ITEM



Art. Z2002090 (pag. 239)

Art. Z2001090 (pag. 239)



Tubo in PVC retinato

Flessibile atossico con doppio rinforzo tessile magliato (TRICOT) ad alta resistenza antitorsione. Resistente agli agenti atmosferici e a gran parte dei prodotti chimici. Temperatura d'impiego da -10° a +60°C. Pressione di esercizio 15 bar. Ideale per il lavaggio della barca o usi vari.

Screened PVC pipe

High resistant PVC pipe with double screened reinforcement (TRICOT). High resistance to atmospheric agents and chemical products. Must to be used with temperatures from -10° to +60° C. Max working pressure 15 bar, excellent for boat cleaning.

| Articolo - Item | €/Reel | mt. | Ø interno-inner mm. | Ø esterno-outer mm. |
|-----------------|--------|-----|---------------------|---------------------|
| N 01 12 018 | | 50 | 12 | 17 |
| N 01 15 021 | | 50 | 15 | 21 |



SUGGESTED ITEM

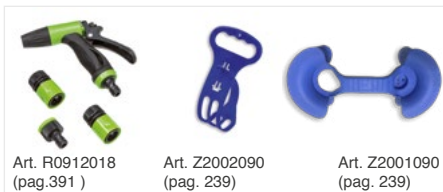

Art. R0912018 (pag.391)

Art. Z2002090 (pag. 239)

Art. Z2001090 (pag. 239)

Kit pistola e raccordi per tubo 12x17mm

Kit water gun and hose fittings 12x17mm

| Articolo - Item | €/pc. | Raccordi-Fittings |
|-----------------|-------|-------------------|
| R 09 12 018 | | 1/2-3/4-1" |



Molletta di ricambio

Spare spring

| Articolo - Item | €/cf. da 10 pz. |
|-----------------|-----------------|
| R 38 08 005 | |



AISI 316 NEW



TUBI LAVAGGIO | WASHING HOSES

23

Kit Washdown lavaggio ponti

- Il kit comprende:
- 1 Autoclave alta pressione 4,2 bar a 5 polmoni;
 - 1 Filtro;
 - 1 Pistola a spruzzo;
 - 3 Raccordi a scatto;
 - 1 Tubo retrattile 7,5 m.

Washdown kit for deck washing

- Kit includes:
- 1 x high-pressure autoclave, 4.2 bar, 5 tanks;
 - 1 Filter;
 - 1 Spraying gun;
 - 3 Snap fittings;
 - 1 Retractable hose 7.5 m.

| Articolo - Item | €/kit. | Volts | Flusso-Flow (lpm) | Pressione max Max pressure (psi) | Consumo Consumption A | kg. |
|-----------------|--------|-------|-------------------|---|-----------------------|-------|
| R 38 12 070 | | 12 | 13,2 | 70 | 10 | 3,380 |
| R 38 60 001 | | | | Tubo, pistola e attacco Hose, gun and connection | | |



R3812070



R3860001

Tubo alta pressione acqua potabile High pressure hose for drinking water

| Articolo - Item | €/pc. | mt. | kg. |
|-----------------|-------|-----|-------|
| N 01 11 838 | | 8 | 0,970 |



Arrotolatore in ABS completo di tubo in PVC e accessori Hose on reel in ABS with PVC tube and accessories

| Articolo - Item | €/pc. | mt. | kg. |
|-----------------|-------|-----|-----|
| N 01 15 305 | | 15 | |



Adattatore di collegamento per rubinetti tondi con diametro 15-25 mm Connection adapter for round taps with 15-25 mm diameter

Senza filetto.

Without thread.

| Articolo - Item | €/pc. | kg. |
|-----------------|-------|-----|
| N 01 65 406 | | |



CUFFIE PER LAVAGGIO MOTORE | ENGINE FLUSHING

Cuffia per lavaggio motori fuoribordo «Universale» Outboard motor flusher «Universal»

Forcella in acciaio plastificato con ventose in gomma e attacco per il raccordo.

Manufactured in plastified steel with rubber suction cup and fitting connection.

| Articolo - Item | €/pc. | Mod. | kg. |
|-----------------|-------|-----------|-------|
| N 26 00 375 | | Universal | 0,300 |

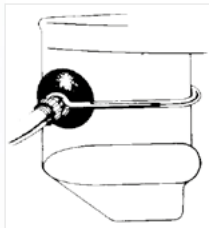

Cuffia per lavaggio motori fuoribordo «Speciale quadrato» Outboard motor flusher «Square Special»

Forcella in acciaio plastificato con ventose in gomma e attacco per il raccordo.

Manufactured in plastified steel with rubber suction cup and fitting connection.

| Articolo - Item | €/pc. | Mod. | kg. |
|-----------------|-------|------------------------------|-------|
| N 26 00 450 | | Cuffia quadra Square flusher | 0,440 |



Cuffia per lavaggio motori fuoribordo «Big» Outboard motor flusher «Big»

Forcella in acciaio plastificato con ventose in gomma e attacco per il raccordo portagomma ø 12 mm.

Manufactured in plastified steel with rubber suction cup and fitting connection.

| Articolo - Item | €/pc. | Mod. | kg. |
|-----------------|-------|------|-------|
| N 26 66 134 | | Big | 0,500 |



Carta igienica biodegradabile **Biodegradable toilet paper**

Rispetta il mare. This product respects the sea.

| Articolo - Item | €/confezione-box | kg. |
|-----------------|------------------|-------|
| Z 18 00 100 | 4 rotoli-reels | 0,260 |



Liquido concentrato per WC chimici

«Fluisan» senza formaldeide al 5% come da normative. Liquido concentrato sterilizzante e deodorante per WC non corrode e non è infiammabile. Biodegradabile.

Liquid for marine toilets «Fluisan»

Eliminates odours. Biodegradable. Concentrated sterilizing liquid and deodorant for WC. It does not corrode and is not flammable.

| Articolo - Item | €/pc. | Lt. | pcs. | kg. |
|-----------------|-------|-----|--------------------|-------|
| Z 18 01 000 | | 1 | 20 fustini-bottles | 1,100 |
| Z 18 04 000 | | 5 | 4 fustini-bottles | 5,200 |



Porta-carta igienica con coperchio impermeabile colore bianco

Completo di viti e biadesivo per l'applicazione.

Toilet paper stand waterproof white colour

Wall mounting by screws or double-sided tape.

| Articolo - Item | €/pc. | mm. | kg. |
|-----------------|-------|---------|-------|
| Z 18 13 150 | | 130x150 | 0,180 |



Spazzolino WC

Provvisto di custodia, montaggio a parete con viti o biadesivo.

Toilet cleaning brush

Suitable for wall application. With container.

| Articolo - Item | €/pc. | mm. | kg. |
|-----------------|-------|--------|-------|
| Z 18 08 026 | | 260x80 | 0,060 |



PORTA RIFIUTI | GARBAGE HOLDER

Porta sacchetti della spazzatura

Questo portarifiuti si fissa a parete in maniera semplice e permanente utilizzando le viti o il biadesivo. Compatibile con sacchetti standard.

Garbage holder

Easy wall mounting by use of screws or double-sided tape. Suitable for standard garbage bags.

| Articolo - Item | €/pc. | mm. | Colore-Colour | kg. |
|-----------------|-------|---------|---------------|-------|
| Z 18 14 031 | | 310x140 | Bianco-White | 0,210 |



DETERGENTI, LUCIDANTI E PROTETTIVI | DETERGENTS & BRIGHTENERS

Crema lucidante pulente protettiva non abrasiva Iosso Fiberglass & Metal Restorer

Performante per ogni tipo di metallo: Acciaio Inossidabile, Bronzo, Ottone Cromato. Ridona colore anche alla Vetroresina invecchiata proteggendola per mesi.

Protective cleaning non abrasive polishing cream Iosso Fiberglass & Metal Restorer

Suitable for any metal: Stainless Steel, Brass, Chromed Bronze. Also restores colour and protects faded fiberglass for a long time.

| Articolo - Item | €/pc. | Contenitore-Container | |
|-----------------|-------|-----------------------|----|
| E 48 50 065 | | Tubetto-Tube 50 ml. | 24 |
| E 48 00 250 | | Lattina-Can 250 ml. | 12 |

IOSSO PRODUCTS

SUGGESTED ITEM

Art. N5800066 Pag. 389

Art. E2950340 Pag. 405

Detergente disincrostante Ferrotone

Detergente disincrostante, dissodificante, desalinizzante. Specifico per pulizia di colature di ruggine sullo scafo, ripristino e pulizia cromature e Acciaio Inox. Ottimo disincrostante per circuiti raffreddamento motori.

Ferrotone descaler detergent

Descaler, desaliner and deoxidizer detergent. Specific for hull rust stains removal, Stainless Steel and Chromed surfaces polishing. Excellent descaler for engines cooling circuit.

| Articolo - Item | €/pc. | Contenitore-Container | |
|-----------------|-------|------------------------|----|
| E 48 01 030 | | Bottiglia-Bottle 1 Lt. | 12 |
| E 48 05 030 | | Canestro-Can 5 Lt. | 4 |

EUROMECI NEW SUGGESTED ITEM

Art. E2950051 Pag. 405

Art. E2950340 Pag. 405

Shampoo ECO

Shampoo per imbarcazioni arricchito con speciali tensioattivi di origine vegetale, totalmente e velocemente biodegradabile. Ideale per la pulizia di vetroresina, superfici verniciate, metallo, gommoni. Con tappo salva bimbo.

Shampoo ECO

Universal shampoo completely biodegradable, for fiberglass, painted surfaces, metal, inflatables, etc. Suitable for cleaning fiberglass, painted surfaces, metal, dinghies.

| Articolo - Item | €/pc. | Contenitore-Container | |
|-----------------|-------|-----------------------|----|
| E 48 01 002 | | Flacone-Bottle 1 Lt. | 12 |

EUROMECI NEW SUGGESTED ITEM

Art. R3802068 Pag. 386

Detergente All Net

Shampoo universale concentrato da diluire 100% biodegradabile per vetroresina, superfici verniciate, metallo e gommoni.

Detergent All Net

100% biodegradable concentrated universal shampoo, to dilute, for fiberglass, painted surfaces, metal and inflatables.

| Articolo - Item | €/pc. | Contenitore-Container | |
|-----------------|-------|-----------------------|----|
| E 48 01 001 | | Flacone-Bottle 1 Lt. | 12 |
| E 48 05 001 | | Canestro-Can 5 Lt. | 4 |

EUROMECI NEW SUGGESTED ITEM

Art. N5880210 Pag. 388

Detergente e cera W&W shampoo

Shampoo per imbarcazioni con l'aggiunta di speciali cere che pulisce a fondo e contemporaneamente dona protezione e brillantezza. Adatto a superfici in vetroresina, parti verniciate e metalliche.

W&W shampoo cleaner & wax

Boat shampoo with special waxes that cleans up and gives protection and brilliance at the same time. Suitable for fiberglass, painted parts and metals.

| Articolo - Item | €/pc. | Contenitore-Container | |
|-----------------|-------|-----------------------|----|
| E 48 01 000 | | Flacone-Bottle 1 Lt. | 12 |
| E 48 05 000 | | Canestro-Can 5 Lt. | 4 |

EUROMECI NEW SUGGESTED ITEM

Art. N5880210 Pag. 388

Art. R3802068 Pag. 386

Art. R3806068 Pag. 386

Detergente Nautico Forte

Potente detergente per la pulizia energica di superfici in vetroresina e alluminio, superfici verniciate, gommoni, parabordi e cuscinerie. Si applica e si lascia agire per 3-5 minuti, poi si strofina con spazzolone o spugna e si risciacqua.

Forte Marine Cleaner

Powerful cleaner for heavy duty cleaning of fiberglass and aluminum surfaces, painted surfaces, inflatables, fenders and seats. Just apply on, leave for 3-5 minutes, then rub with scrub or sponge and rinse with water.

| Articolo - Item | €/pc. | Contenitore-Container | |
|-----------------|-------|-----------------------|----|
| E 48 03 750 | | Spray bottle 750 ml. | 12 |

EUROMECI NEW SUGGESTED ITEM

Art. N5880210 Pag. 388

Art. R3806068 Pag. 386

Decapante rinnovatore per gommoni GommoStrip

Detergente decapante che rinnova, pulisce e ripristina il colore originale dei gommoni invecchiati dal sole, dallo smog e dalla salsedine. Adatto a tutti i tipi di gomma. Si spruzza sulla gomma, dopo alcuni minuti si spazzola e si risciacqua.

GommoStrip Inflatable Cleaner Renewer

Renews, cleans and restores the original color of the inflatables aged by the sun, smog and salt. Suitable for all types of rubber. Spray on rubber and, after few minutes, brush and rinse.

| Articolo - Item | €/pc. | Contenitore-Container | |
|-----------------|-------|-----------------------|----|
| E 48 01 750 | | Spray bottle 750 ml. | 12 |
| E 48 01 005 | | Canestro-Can 5 Lt. | 4 |

EUROMECI NEW SUGGESTED ITEM

Art. N5880210 Pag. 388

Cera rigenerante per gommoni Gommowax

Cera rigenerante, detergente e protettiva per gommoni di qualsiasi materiale. Mantiene il gommone morbido e protetto a lungo, ridonando l'aspetto originale alla gomma invecchiata.

Gommowax Inflatable Restore Wax

Restoring, cleaning and protecting wax for any type of rubber boats. Makes the inflatable soft and long time protected, restores the original look of the wearied rubber.

| Articolo - Item | €/pc. | Contenitore-Container | |
|-----------------|-------|-----------------------|----|
| E 48 02 750 | | Spray bottle 750 ml. | 12 |

EUROMECI NEW

Antimuffa Muffanet

Elimina le macchie di muffa. Per gommoni di ogni materiale, vetroresina, Teak.

Stains remover

Eliminates mildew stains from cushions in sky leather, rubber boats, fiberglass and other materials washable.

| Articolo - Item | €/pc. | Contenitore-Container | |
|-----------------|-------|------------------------|----|
| E 48 00 750 | | Flacone-Bottle 750 ml. | 12 |

EUROMECI NEW SUGGESTED ITEM

Art. N5880210 Pag. 388

Detergente per Teak «Pen Teak Cleaner» **Teak cleaner «Pen Teak Cleaner»**

Per la pulizia frequente delle coperte in Teak.

For frequent cleaning of teak decks.

| Articolo - Item | €/pc. | Contenitore-Container | |
|-----------------|-------|-----------------------|----|
| E 48 01 006 | | Flacone-Bottle 1 Lt. | 12 |
| E 48 05 006 | | Flacone-Bottle 5 Lt. | 4 |

EM NEW SUGGESTED ITEM



Olio protettivo per Teak «Pen Teak Oil» **Teak sealer «Pen Teak Oil»**

Ravviva e protegge il Teak. Senza siliconi.

It's a wood treatment to replace natural oils removed by weathering.

| Articolo - Item | €/pc. | Contenitore-Container | |
|-----------------|-------|-----------------------|---|
| E 48 04 750 | | Lattina-Can 0,750 Lt. | 6 |
| E 48 04 004 | | Lattina-Can 4 Lt. | 4 |

EM NEW SUGGESTED ITEM



Rinnovatore e sbiancatore per Teak **Teak restorer**

Sbianca e pulisce a fondo il Teak ingrigito.

Restores old teak removing the grey colour and giving again the original colour of new teak.

| Articolo - Item | €/pc. | Contenitore-Container | |
|-----------------|-------|-----------------------|----|
| E 48 01 003 | | Lattina-Can 1 Lt. | 12 |
| E 48 05 003 | | Lattina-Can 5 Lt. | 4 |

EM NEW SUGGESTED ITEM



Powder Net **Powder Net**

È un detergente sbiancante acido in polvere per la pulizia di Teak, vetroresina, acciaio. Rimuove con facilità le incrostazioni sul gelcoat, la ruggine dall'acciaio, rinnova e sbianca il Teak.

Powder Net is an acid brightener, in powder, for the energetic cleaning of fiberglass, steel and teak.

| Articolo - Item | €/pc. | Contenitore-Container | |
|-----------------|-------|------------------------|----|
| E 48 05 750 | | Spray bottle 0,750 Lt. | 12 |

EM NEW SUGGESTED ITEM



Protettivo per legno Teak e Doussié **Protective oil for wooden Teak and Doussié**

Prodotto pronto uso, formulato per proteggere e ravvivare il legno, per esterni. Indicato per coperte e particolari in legno Teak, Iroko, Doussié, ecc.

Ready to use product. Penetrates deep into wood for extra protection.

| Articolo - Item | €/pc. | Contenitore-Container | |
|-----------------|-------|-----------------------|--|
| E 28 01 473 | | Lattina-Can 1 Lt. | |

EM NEW SUGGESTED ITEM



Sgrassante detergente «Bilge» **«Bilge» cleaner**

Concentrato, profumato, per la pulizia di sentine, vetroresina, plastiche, vernici, giranti, pompe. Con tappo salva bimbo.

Bilge is a powerful liquid bilge cleaner. High grease solvency for fast effective action.

| Articolo - Item | €/pc. | Contenitore-Container | |
|-----------------|-------|-----------------------|----|
| E 48 01 004 | | Flacone-Bottle 1 Lt. | 12 |

EM NEW



DEUMIDIFICATORI E ASSORBENTI | DEHUMIDIFIERS & ABSORBENTS

Assorbenti tubolari **Tubular absorbents**

Manicotti in materiale speciale che assorbe olio e idrocarburi ma repelle l'acqua. Assorbono 20 volte il loro peso in olio o carburante. Si usano in caso di operazioni cambio olio, rifornimento carburante etc, per evitare versamenti in mare o in sentina.

Special material absorbent tubulars that soak up oil and fuel but repel water. They absorb 20 times their weight in oil or fuel. Used when refurbishing fuel or changing oil etc, to avoid fuel/oil loosing into surrounding water.

| Articolo - Item | €/pc. | Ø cm. | Lunghezza Length cm. |
|-----------------|-------|-------|----------------------|
| E 48 08 120 | | 8 | 120 |
| E 48 08 240 | | 8 | 240 |

EM NEW



Assorbente per olio e idrocarburi **Oil and fuel absorbent**

Manicotto tubolare in materiale speciale che assorbe olio e idrocarburi ma repelle l'acqua. Ideale per operazioni di cambio olio, rifornimento carburante e per evitare versamenti in mare o in sentina.

Special material tubular absorbent that soaks up oil and fuel but repels water. Ideal when refurbishing fuel or changing oil and to avoid fuel/oil loosing into surrounding water.

| Articolo - Item | €/pc. | Ø cm. | Lunghezza Length cm. |
|-----------------|-------|-------|----------------------|
| E 48 08 030 | | 8 | 30 |

EM NEW



«Torr-Ball» il deumidificatore originale **«Torr-Ball» the original dehumidifier**

Torr-Ball deumidifica gli ambienti evitando ruggine, corrosione, muffa, marciume ed aria stantia. Funziona senza la necessità di costose installazioni e senza consumo di energia. Entra in funzione appena i suoi cristalli sono esposti ad un ambiente umido e agisce fino a 3 mesi senza manutenzione. La confezione è completa di contenitore con ricarica da 500 gr. di cristalli.

Torr-Ball creates a damp free environment, eliminating rust, corrosion, mild, grime and musty odours. It doesn't need expensive installations or energy consumption. Starts working as soon as its crystals are in contact with dampness and works for 3 months without upkeep. The pack contains inner basket and 500 gr. crystals refill.

| Articolo - Item | €/pc. | Mod. | |
|-----------------|-------|---------------------------|----|
| E 48 00 000 | | TorrBall + Refill 500 gr. | 12 |
| E 48 01 500 | | Ricarica-Refill 500 gr. | 36 |
| E 48 01 100 | | Ricarica-Refill 1 kg. | 12 |

EM NEW



OLI E LUBRIFICANTI | OILS & ENGINE LUBRICANTS

Grasso Blue Grease Blue Grease

Grasso semisintetico fortemente adesivo e idrorepellente, non asportabile da pioggia, acqua di mare e forza centrifuga. Rende stagne le chiusure filettate. Indicato per la lubrificazione e la protezione di lunga durata di tutte le attrezzature di bordo.

Semisynthetic grease with great adhesion, water-repellent, not washable by rain, salt water or centrifugal force. Makes watertight all threaded locks. Suitable for lubrication and long lasting protection of all equipment on board.

| Articolo - Item | €/pc. | Contenitore-Container |
|-----------------|-------|-----------------------|
| E 28 08 125 | 12 | Tubetto-Tube 125 ml. |
| E 28 08 500 | 24 | Lattina-Can 500 ml. |



Grasso bianco al Litio

Grasso Bianco al Litio, adesivo, persistente, non sporca. Lubrifica e protegge dalla corrosione, resiste al dilavamento e alla centrifugazione. Specifico per ingranaggi scoperti, boccole e perni non protetti, cavi comando e timonerie.

Ferrotone descaler detergent

Highly adhesive, persistent, non smudging Lithium White grease. Lubricates and protects against corrosion, resists to water and sea splashing and to centrifugation. Indicated for not covered gears, not protected studs, bearings, remote control cables and steering systems.

| Articolo - Item | €/pc. | Contenitore-Container |
|-----------------|-------|-----------------------|
| E 28 01 300 | | Tubetto-Tube 125 ml. |



CRC 6-66 Marine

Protegge contro l'azione corrosiva dell'ambiente salino, sblocca, deterge e lubrifica tutto. Idrorepellente, idrorepellente, non altera la conducibilità dei contatti elettrici.

CRC 6-66 Marine

Protects against marine salt corrosion, unblocks, cleans and lubricates everything. Water repellent, hydrophobic, does not alter the conductivity of the electrical contacts.

| Articolo - Item | €/pc. | Contenitore-Container |
|-----------------|-------|-----------------------|
| E 28 00 200 | | Spray 200 ml. |
| E 28 00 400 | | Spray 400 ml. |
| E 28 00 020 | | Latta 20 lt. |



Grasso TK Grease TK Grease

Grasso bianco allo Zinco di grande adesività raccomandato per proteggere, lubrificare ed evitare il bloccaggio dei bulloni, morsetti delle batterie, serrature e attrezzature operanti in ambienti corrosivi e sotto l'azione dilavante dell'acqua.

Great adherence Zinc-based white grease recommended to protect, lubricate and avoid gripping of nuts, battery terminals, locks and hardware working in corrosive environments and under the water rinsing action.

| Articolo - Item | €/pc. | Contenitore-Container |
|-----------------|-------|-----------------------|
| E 39 40 010 | | Tubetto-Tube 250 ml. |



Olio Q8 «Outboard» per motori 2 tempi

«Outboard» Q8 oil for 2 cycle engines

| Articolo - Item | €/pc. | Contenitore-Container |
|-----------------|-------|-----------------------|
| E 09 08 001 | | Flacone-Bottle 1 Lt. |



Gear Oil

Olio piede antiossidante e antiusura per motori fuoribordo. Riduce il consumo degli ingranaggi e si mantiene nei periodi di inattività.

Gear Oil

Outboard gear lube with special anti-wear and corrosion inhibitors additives. Reduces gear consumption and preserve the engine during inactivity periods.

| Articolo - Item | €/pc. | Contenitore-Container |
|-----------------|-------|-----------------------|
| E 39 40 015 | | Tubetto-Tube 250 ml. |



Lubrificante «WD 40» «WD 40» lubricant

| Articolo - Item | €/pc. | ml. | Contenitore-Container |
|-----------------|-------|-----|-----------------------|
| E 40 00 200 | 200 | 36 | 1 |
| E 40 00 400 | 400 | 24 | 1 |



Additivo Anti alga Diesel

Dosaggio: una confezione da 250 ml ogni 300 lt.

Anti algae additive for Diesel engines

Dosage: 250 ml every 300 liters.

| Articolo - Item | €/pc. | Contenitore-Container |
|-----------------|-------|------------------------|
| E 09 00 009 | | Flacone-Bottle 250 ml. |



Additivo multifunzionale Diesel

Pulisce e lubrifica i sistemi di alimentazione Diesel ed elimina la formazione di condensate nei serbatoi. Aumenta il numero di cetani ottimizzando combustione e resa. Elimina la formazione di flora batterica nei serbatoi. Dosaggio: una confezione da 300 ml ogni 500 lt.

Multifunctional additive for Diesel engines

It cleans and lubricates diesel engine system and eliminates condensate residues. Eliminates bacterial flora in the engine tanks. It increases the number of the cetanes. Dosage: 300 ml every 500 liters.

| Articolo - Item | €/pc. | Contenitore-Container |
|-----------------|-------|------------------------|
| E 09 00 002 | | Flacone-Bottle 300 ml. |



Additivo multifunzionale Motori Benzina 2 e 4 tempi

Pulisce e lubrifica i sistemi di alimentazione e serbatoi. Aumenta il numero degli ottani ottimizzando combustione e resa. Elimina depositi di zolfo e olio miscela dai fondi dei serbatoi.

Multifunctional additive for 2 and 4 stroke engines

It cleans and lubricates all the engines 2 and 4 strokes and eliminates condensate residues. Eliminates sulfur and oil from the fuel tank. It increases the number of the octanes.

| Articolo - Item | €/pc. | ml. | Motori Engines | Contenitore-Container | Dosaggio Dosage |
|-----------------|-------|-------------|----------------|-----------------------|-----------------|
| E 09 00 004 | 100 | < 15 Hp | 24 | 100/50Lt. | |
| E 09 00 003 | 200 | >15-100 Hp< | 12 | 100/200Lt. | |
| E 09 00 001 | 300 | >100 Hp | 12 | 100/500Lt. | |



«GEL COAT»

«Gelcoat filler»

kit di riparazione e finissaggio su scafi in glass fibre (vetroresina) colore bianco. Indicato per la riparazione di danni anche notevoli su barche in vetroresina, caravan, ecc. Può essere pigmentato o verniciato con tutte le vernici nautiche. Provvisto all'interno di istruzioni per l'uso. Confezione contenente un tubetto di gelcoat filler ed accessori per l'impiego.

«Gelcoat filler»

Repair kit white colour. White Gelcoat suitable for scratches on fiberglass surfaces. Packing including a little tube of gelcoat filler and accessories.

| Articolo - Item | €/Kit | Contenuto-Capacity ml. | kg. |
|-----------------|-------|------------------------|-------|
| E 39 00 180 | | 180 | 0,210 |



«Marine filler»

Riempiente formulato appositamente per applicazioni marine. Può essere usato sul legno, alluminio e vetroresina. Può essere inoltre verniciato con qualsiasi vernice nautica.

«Marine filler»

Suitable for application on wood, aluminium, fiberglass. To be used with any kind of boat painting.

| Articolo - Item | €/Kit | Contenuto-Capacity ml. | kg. |
|-----------------|-------|------------------------|-------|
| E 39 44 180 | | 180 | 0,190 |



Kit 10 spatole in plastica per applicazione stucco

Ideali per la stuccatura.

Kit of 10 plastic taping knives

Suitable for stucco application.

| Articolo - Item | €/Kit | Kit pcs. | kg. |
|-----------------|-------|----------|-------|
| E 39 00 151 | | 10 | 0,100 |



Gel Coat spray TK

Vernice spray ad alta densità per vetroresina rivestite con Gelcoat e resina Poliester. Ripristina le parti trattate in maniera uniforme e consente una veloce copertura livellando le porosità.

TK Gel Coat spray

High density spray paint for fiberglass treated with gelcoat and Polyester resin. Renews treated surfaces equally and allows a quick cover by flattening porosities.

| Articolo - Item | €/pc. | Contenitore-Container |
|-----------------|-------|--------------------------|
| E 39 40 304 | | Spray 400 ml. White |
| E 39 40 604 | | Spray 400 ml. Pure White |



SIKAFLEX 290 PRO

Sigillante monocomponente appositamente sviluppato per il calafataggio di giunti per la realizzazione di ponti in Teak, basato sulla recente tecnologia poliuretana i-cure. Il materiale ha eccellenti caratteristiche di lavorabilità e carteggiatura, reticola in presenza dell'umidità formando un elastomero durevole.

| Articolo - Item | €/pc. | Colore-Colour | Contenitore-Container |
|-----------------|-------|---------------|-----------------------------|
| E 37 80 290 | | Nero-Black | Cartuccia-Cartridge 300 ml. |



SUGGESTED ITEM



Art. E3711068 (pag. 398)

SIKAFLEX 291

SIKAFLEX 291

Sigillante multifunzionale monocomponente basato sulla recente tecnologia poliuretana i-cure, utilizzato nell'industria navica e navale. Si applica a sigillature elastiche durevoli nel tempo, aderisce perfettamente ai più comuni substrati.

Polyurethane based i-cure new technology multipurpose sealant used in boat and marine construction. Suitable for elastic and durable seals and it bonds well to a most common variety of substrates.

| Articolo - Item | €/pc. | Colore-Colour | Contenitore-Container |
|-----------------|-------|---------------|-----------------------------|
| E 37 80 291 | | Nero-Black | Cartuccia-Cartridge 300 ml. |
| E 37 74 291 | | Bianco-White | Cartuccia-Cartridge 300 ml. |



SUGGESTED ITEM



Art. E3711068 (pag. 398)

SIKAFLEX 292 I

Adesivo pastoso monocomponente con proprietà tixotropiche, basato sulla recente tecnologia poliuretana i-cure, utilizzato nell'industria navica per realizzare giunti adesivi in strutture soggette ad elevate sollecitazioni dinamiche. Reticola con l'esposizione all'umidità formando un elastomero durevole, caratterizzato da eccellenti proprietà adesive e da elevati valori di resistenza meccanica.

SIKAFLEX 292 I

Polyurethane based i-cure new technology thixotropic monocomponent pasty sealant used in marine industry for making adhesive couplings in high dynamic stress structures. The product dries on humidity exposure and forms a durable elastomer characterized by excellent adhesive properties and high level of mechanical resistance.

| Articolo - Item | €/pc. | Colore-Colour | Contenitore-Container |
|-----------------|-------|---------------|-----------------------------|
| E 37 74 292 | | Bianco-White | Cartuccia-Cartridge 300 ml. |



SUGGESTED ITEM



Art. E3711068 (pag. 398)

SIKAFLEX 295 I-UV

Adesivo sigillante monocomponente specifico per l'industria navica, basato sulla recente tecnologia poliuretana i-cure. Si utilizza per l'incollaggio di Vetri organici e per sigillature esposte ai raggi UV. Reticola con l'esposizione all'umidità formando un elastomero durevole.

SIKAFLEX 295 I-UV

Monocomponent adhesive sealant specific for marine industry, based on new polyurethane i-cure technology. Used to bond organic glazing materials and for UV exposed seals. Dries on humidity exposure and forms a durable elastomer.

| Articolo - Item | €/pc. | Colore Colour | Contenitore Container |
|-----------------|-------|---------------|-----------------------------|
| E 37 80 295 | | Black | Cartuccia Cartridge 300 ml. |
| E 37 74 295 | | White | Cartuccia Cartridge 300 ml. |



SUGGESTED ITEM



Art. E3711068 (pag. 398)

Sigillante monocomponente resistente ai raggi UV

Campi di applicazione: Sigillature esterne per metalli, porte, finestre, bagni.
Vantaggi:
• non ingiallisce • lunga durata nel tempo • non ammuflisce • senza solventi • non corrosivo • sovraverniciabile

One-part formulation sealant, UV resistant

Areas of application: external sealing for metals, doors, windows, toilets
Advantages:
• no yellowing • long lasting • do not go mouldy • without solvents • non corrosive • can be overpainted

| Articolo - Item | €/pc. | Colore-Colour | ml. |
|-----------------|-------|---------------|-----|
| E 37 74 521 | | Bianco-White | 310 |



SUGGESTED ITEM



Art. E3711068 (pag. 398)

Adesivo elastico ad alta resistenza

Campi di applicazione: ideale per legno, metalli, alluminio (anche anodizzato) e lamiera.
Vantaggi:
• monocoprente • elastico sovraverniciabile • non corrosivo • smorza le vibrazioni • carteggiabile

| Articolo - Item | €/pc. | Colore-Colour | ml. |
|-----------------|-------|---------------|-----|
| E 37 74 252 | | Bianco-White | 310 |



SUGGESTED ITEM



Art. E3711068 (pag. 398)

High tenacity structural adhesive

Areas of application: timber, metals, aluminium, sheet steel.
Product benefits:
• one-part formulation • elastic can be overpainted • non-corrosive • can be sanded • capable of withstanding high dynamic stresses

Pistola per cartucce Caulking gun

Pistola per cartucce di buona qualità e durata. Good quality and durability caulking gun.

| Articolo - Item | €/pc. |
|-----------------|-------|
| E 37 11 068 | |



Kit riparazione gommoni in neoprene

Repair kit for rubber boats

Confezione contenente:
 • n. 4 Rappazzi tondi tessuto per gommoni
 • n. 4 Rappazzi rettangolari tessuto per gommoni
 • n. 1 Rappazzo ovale tessuto per gommoni
 • n. 1 Tubetto collante speciale
 • n. 1 Spatola spalmatrice
 • n. 1 Tela abrasiva

Each set containing different sizes of neoprene fabric, one tube of special glue, accessories for repairing and sticking.

| Articolo - Item | €/Kit | Colore-Colour | kg. |
|-----------------|-------|---------------|-------|
| E 43 00 180 | | | 0,180 |
| E 47 00 180 | | | 0,180 |
| E 48 00 180 | | | 0,180 |
| E 45 00 180 | | | 0,180 |

NEOPRENE HYPALON



Tessuto in PVC

PVC fabric

Spessore 0,9 mm.

Thickness 0,9 mm.

| Articolo - Item | €/pc. | Colore-Colour | mm. |
|-----------------|-------|---------------|---------|
| E 38 75 031 | | | 300x300 |
| E 38 79 031 | | | 300x300 |
| E 38 80 031 | | | 300x300 |
| E 38 74 031 | | | 300x300 |

PVC



Tessuto in Neoprene

Neoprene fabric

Spessore 0,9 mm.

Thickness 0,9 mm.

| Articolo - Item | €/pc. | Colore-Colour | mm. |
|-----------------|-------|---------------|---------|
| E 38 70 030 | | | 300x300 |
| E 38 79 030 | | | 300x300 |
| E 38 80 030 | | | 300x300 |
| E 38 74 030 | | | 300x300 |

NEOPRENE HYPALON



Kit adesivo PVC

PVC Adhesive kit

| Articolo - Item | €/Kit | Contenuto Capacity gr. | Attivatore Activator |
|-----------------|-------|------------------------|----------------------|
| E 38 00 121 | | 125 | (10 gr) |
| E 38 00 401 | | 350 | (30 gr) |

ATTIVATORE COMPRESO NEL KIT



Kit adesivo Neoprene

Neoprene Adhesive kit

| Articolo - Item | €/Kit | Contenuto Capacity gr. | Attivatore Activator |
|-----------------|-------|------------------------|----------------------|
| E 38 00 120 | | 125 | (10 gr) |
| E 38 00 400 | | 350 | (30 gr) |

ATTIVATORE COMPRESO NEL KIT



Diluyente

Diluyente specifico per pulire e ravvivare il tessuto prima dell'applicazione del collante o per diluire il collante stesso.

Diluent

Specific diluent for cleaning and reviving the fabric before the application of the glue or to dilute the glue.

| Articolo - Item | €/pc. | Mod. | ml. |
|-----------------|-------|--|-----|
| E 38 00 250 | | Diluyente per neoprene Diluent for neoprene | 100 |
| E 38 00 251 | | Diluyente per PVC Diluent for PVC | 100 |



Kit riparazione gommoni in neoprene

Repair kit for rubber boats

Confezione contenente:
 • n. 4 Rappazzi tondi tessuto per gommoni
 • n. 4 Rappazzi rettangolari tessuto per gommoni
 • n. 1 Rappazzo ovale tessuto per gommoni
 • n. 1 Tubetto collante speciale
 • n. 1 Spatola spalmatrice
 • n. 1 Tela abrasiva

Each set containing different sizes of neoprene fabric, one tube of special glue, accessories for repairing and sticking.

| Articolo - Item | €/pc. | Mod. | Contenuto Contents gr. | kg. |
|-----------------|-------|--------|------------------------|-------|
| E 38 00 030 | | Small | 18 | 0,030 |
| E 38 00 095 | | Medium | 50 | 0,070 |
| E 38 00 125 | | Large | 125 | 0,159 |



Collante mono-coprente in PVC

PVC Single-layer adhesive

| Articolo - Item | €/pc. | Contenuto Contents ml. |
|-----------------|-------|------------------------|
| E 38 30 000 | | 30 |



Sigillante «Aquaresure»

Adesivo sigillante forte, resistente a calore e solventi, flessibile e a tenuta d'acqua. Per riparare mute, tende, cappe, cerate, stivali etc. Ripara piccoli fori e strappi ricostruendo le parti mancanti senza toppe.

«Aquaresure» sealant

Strong, flexible, waterproof, heat and solvents resistant adhesive sealant. Used to repair suits, tents, cloaks, dry suits, boots, etc. Repairs small holes and rips by reconstructing missing parts, without patches.

| Articolo - Item | €/Blister | Contenitore-Container |
|-----------------|-----------|-------------------------|
| E 48 02 007 | | 2 Tubetti-Tubes 2x7 gr. |



EM NEW



ADESIVI PER RIPARAZIONI | REPAIR ADHESIVE TAPES

Adesivo riparazione vele «Spinnaker repair tape»

Nastro adesivo speciale per riparare le vele.

Repair adhesive tape for sails «Spinnaker repair tape»

Special adhesive tape for sail repair.

| Articolo - Item | €/Rotolo-Reel | H mm. | Colore Colour | mt. | kg. |
|-----------------|---------------|-------|---------------|-----|-------|
| E 46 52 009 | | 50 | Bianco-White | 4,5 | 0,100 |
| E 49 52 009 | | 50 | Rosso-Red | 4,5 | 0,100 |
| E 48 52 009 | | 50 | Blue Sea | 4,5 | 0,100 |
| E 43 52 009 | | 50 | Orange | 4,5 | 0,100 |



Adesivo per riparazione vele

Repair adhesive tape for sails

| Articolo - Item | €/Rotolo-Reel | H mm. | Colore Colour | mt. | kg. |
|-----------------|---------------|-------|---------------|-----|-------|
| E 46 50 084 | | 50 | Bianco-White | 2,0 | 0,100 |



Nastro in PVC autoamalgamante

Indicato per il rivestimento di parti elettriche, finiture di impiombature, bloccaggio di tenditori ed arridatoi, ecc. Colore nero.

PVC self-adhesive tape

Suitable for the coating of electrical parts. Black colour.

| Articolo - Item | €/Rotolo-Reel | H mm. | mt. | kg. |
|-----------------|---------------|-------|-----|-------|
| E 35 19 080 | | 19 | 5,0 | 0,100 |



Nastro adesivo in Pvc espanso morbido per oblò, passi uomo, finestrini, ecc.

Nastro in espanso morbido a cellule chiuse autoadesivo, indicato per ricreare la tenuta stagna negli oblò, passi uomo, finestrini, ecc.

Pvc foamed adhesive tape for portholes, hatches, doors

Suitable for the good tight-seal of the doors.

| Articolo - Item | €/Rotolo-Reel | H mm. | Spessore Thickness mm. | mt. | kg. |
|-----------------|---------------|-------|------------------------|-----|-------|
| E 35 15 095 | | 19 | 3 | 3,0 | 0,100 |



Adesivo resistente ai raggi UV «Duck Tape»

Nastro in tessuto adesivo ad alta tenacità, ideale per riparare tessuti e vele. Modello impermeabile resistente ai raggi UV.

UV resistant adhesive tape «Duck Tape»

High tenacity adhesive tape. Suitable for fabric and sail repair. Waterproof and UV resistant.

| Articolo - Item | €/pc. | mm. | Colore Colour | kg. |
|-----------------|-------|----------------|---------------|-------|
| E 46 74 050 | | 50 mm. x 5 mt. | Bianco-White | 0,140 |
| E 46 79 050 | | 50 mm. x 5 mt. | Grigio-Grey | 0,140 |
| E 46 80 050 | | 50 mm. x 5 mt. | Nero-Black | 0,140 |



Adesivo in fibra di vetro bicomponente

Ideale per riparazione di canoe e kayaks. Fibra di vetro da un lato e dall'altro un'applicazione di resinaepossidica. Si applica da 5 a 15 minuti.

Fibreglass adhesive tape

Suitable for canoe and kayak repair. Application time 5/15 minutes.

| Articolo - Item | €/pc. | mm. | Colore Colour | kg. |
|-----------------|-------|---------|-------------------------|-------|
| E 35 77 150 | | 100x150 | Trasparente-Transparent | 0,140 |
| E 35 82 300 | | 100x300 | Trasparente-Transparent | 0,140 |



Nastro per rigging

Rigging tape

| Articolo - Item | €/pc. | mm. x mt. | kg. |
|-----------------|-------|-----------|-------|
| E 37 25 005 | | 25x5 | 0,050 |



Antisdrucchiole adesive in rotoli

Adesivo antiscivolo, protegge contro le cadute da scivolamento nelle imbarcazioni.

Antisliding adhesive tape in rolls

Adhesive anti-sliding material. It prevents falls due to sliding on boats.

| Articolo - Item | €/mt. | € | H mm. | Colore Colour | mt. | kg. |
|-----------------|-------|---|-------|---------------|-----|-------|
| D 16 25 000 | | | 25 | White | 20 | 1,000 |
| D 16 05 000 | | | 50 | White | 20 | 1,500 |
| D 16 10 000 | | | 100 | White | 20 | 2,000 |

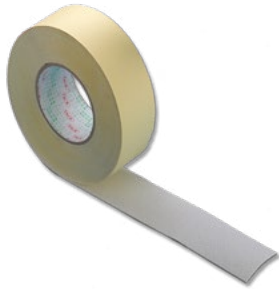

Espositore rotoli di anti-sdrucchiole

Art. D 29 00 000

Rack for antisliding rolls

Item D 29 00 000

€/Box

Colore bianco.

White colour.

| Quantità-Quantity | Articoli presenti - Items included | H mm. |
|-------------------|------------------------------------|-------|
| 1 rotolo-reel | D 16 25 000 | 25 |
| 1 rotolo-reel | D 16 05 000 | 50 |
| 1 rotolo-reel | D 16 10 000 | 100 |



Strisce adesive antisdrucchiole «Self service»

Strisce adesive antiscivolo, proteggono contro le cadute da scivolamento nelle imbarcazioni.

Antisliding adhesive stripes «Self service»

Adhesive anti-sliding material stripes. It prevents falls due to sliding on boats.

| Articolo - Item | €/Kit | Striscia-Tape cm. | Colore-Colour |
|-----------------|-------|-------------------|---------------|
| D 16 00 050 | | 25 | Bianco-White |



Antisdrucchiole adesivo «Soft Grip»

Nastro gommoso antisdrucchiole conformabile, provvisto di speciale adesivo che non lascia residui una volta rimosso. Fornisce un grip extra ove necessario.

Antisliding adhesive tape «Soft Grip»

Comfortable rubber antisliding tape. Extra grip when necessary.

| Articolo - Item | €/pc. | Colore-Colour | mm. x mt. | kg. |
|-----------------|-------|---------------|-----------|-------|
| D 16 50 079 | | Grigio-Grey | 50x4 | 0,170 |



Nastro anti-sfregamento

Anti-rubbing adhesive tape

| Articolo - Item | €/pc. | mm. x mt. | kg. |
|-----------------|-------|-----------|-------|
| D 16 05 003 | | 50x3 | 0,080 |
| D 16 05 002 | | 50x2 | 0,080 |





HEMPEL

Keep Sailing

ANTIVEGETATIVE | ANTIFOULING «HEMPEL»



Antivegetativa autolevigante «MILLE NCT»

Antivegetativa autolevigante ad elevate prestazioni, Nano Capsule Technology (brevetto Hempel). Adatta a qualunque tipo di imbarcazione, è compatibile con la maggior parte delle antivegetative. Non adatta per alluminio e leghe leggere.

| Colore - Colour | Articolo - Item | Lt. | €/pc. | kg. | Articolo - Item | Lt. | €/pc. | kg. |
|-----------------|-----------------|------|-------|-------|-----------------|------|-------|-------|
| Black 19990 | E 70 80 075 | 0,75 | - | 1,200 | E 70 80 250 | 2,50 | - | 4,000 |
| Blue 30390 | E 70 75 075 | 0,75 | - | 1,200 | - | - | - | - |
| Souvenirs Blue | E 70 73 075 | 0,75 | - | 1,200 | E 70 73 250 | 2,50 | - | 4,000 |
| Red 56460 | - | - | - | - | E 70 82 250 | 2,50 | - | 4,000 |
| White 10000 | E 70 74 075 | 0,75 | - | 1,200 | E 70 74 250 | 2,50 | - | 4,000 |



Self polishing antifouling «MILLE NCT»

High performance self polishing antifouling with Nano Capsule Technology (patented by Hempel). Suitable for every kind of boat, compatible with most antifouling. Not suitable for aluminium and light alloys.

SUGGESTED ITEM

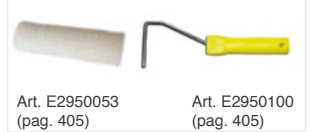

Art. E2950053
(pag. 405)

Art. E2950100
(pag. 405)



Antivegetativa autolevigante «CRUISING PERFORMER»

Antivegetativa autolevigante ad uso stagionale, contenente ossido di rame. Non adatta per alluminio e leghe leggere.

| Colore - Colour | Articolo - Item | Lt. | €/pc. | kg. | Articolo - Item | Lt. | €/pc. | kg. |
|-----------------|-----------------|------|-------|-------|-----------------|------|-------|-------|
| Black 19990 | E 72 80 075 | 0,75 | - | 1,300 | E 72 80 250 | 2,50 | - | 4,500 |
| Blue 30390 | - | - | - | - | E 72 75 250 | 2,50 | - | 4,500 |
| Red 56460 | - | - | - | - | E 72 82 250 | 2,50 | - | 4,500 |



Self polishing antifouling «CRUISING PERFORMER»

Self polishing antifouling for seasonal use containing copper oxide. Not suitable for aluminium and light alloys.

SUGGESTED ITEM

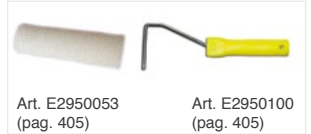

Art. E2950053
(pag. 405)

Art. E2950100
(pag. 405)



Antivegetativa a matrice dura «HARD RACING TECCEL»

Antivegetativa a matrice dura per una finitura liscia che riduce l'attrito.

| Colore - Colour | Articolo - Item | Lt. | €/pc. | kg. | Articolo - Item | Lt. | €/pc. | kg. |
|-----------------|-----------------|------|-------|-------|-----------------|------|-------|-------|
| Black 19990 | E 73 80 075 | 0,75 | - | 1,200 | E 73 80 250 | 2,50 | - | 4,000 |
| Blue 30390 | E 73 75 075 | 0,75 | - | 1,200 | E 73 75 250 | 2,50 | - | 4,000 |
| Sky blue 31750 | E 73 73 075 | 0,75 | - | 1,200 | E 73 73 250 | 2,50 | - | 4,000 |
| Red 56460 | - | - | - | - | E 73 82 250 | 2,50 | - | 4,000 |
| White 10000 | E 73 74 075 | 0,75 | - | 1,200 | E 73 74 250 | 2,50 | - | 4,000 |



Hard antifouling «HARD RACING TECCEL»

Hard antifouling for a smooth finish which reduces the friction.

SUGGESTED ITEM

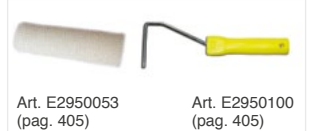

Art. E2950053
(pag. 405)

Art. E2950100
(pag. 405)



Antivegetativa a matrice dura «BRAVO»

Antivegetativa a matrice dura ideale per acque temperate e brevi intervalli di carenaggio.

| Colore - Colour | Articolo - Item | Lt. | €/pc. | kg. | Articolo - Item | Lt. | €/pc. | kg. |
|-----------------|-----------------|------|-------|-------|-----------------|------|-------|-------|
| Black 19990 | E 74 80 075 | 0,75 | - | 1,300 | - | - | - | - |
| Souvenirs Blue | E 74 73 075 | 0,75 | - | 1,300 | E 74 73 250 | 2,50 | - | 4,000 |
| Blue 30390 | E 74 75 075 | 0,75 | - | 1,300 | E 74 75 250 | 2,50 | - | 4,000 |
| Red 51170 | E 74 82 075 | 0,75 | - | 1,300 | - | - | - | - |



Hard antifouling «BRAVO»

Hard antifouling suitable for temperate waters and short dock.

SUGGESTED ITEM



Art. E2950053
(pag. 405)

Art. E2950100
(pag. 405)

PRIMER E FONDI | PRIMERS «HEMPEL»

«UNDERWATER PRIMER»

Primer universale monocomponente per carene di qualunque materiale o come sigillante della vecchia anti-vegetativa. Prodotto a base di caucciù, contiene pigmenti di alluminio in scaglie.

«UNDERWATER PRIMER»

Universal one-component primer suitable for every kind of hull or as sealant of old antifouling. Made with a base of Caoutchouc rubber.

| Colore - Colour | Articolo - Item | Lt. | €/pc. | kg. |
|-----------------|-----------------|------|-------|-------|
| Aluminium 19000 | E 75 31 075 | 0,75 | | 1,000 |



MONOCOMPONENTI | MONO-COMPONENT

SUGGESTED ITEM



Art. E2950053
(pag. 405)

Art. E2950100
(pag. 405)



«LIGHT PRIMER»

Primer e fondo epossidico bicomponente, da utilizzare sia al di sopra che al di sotto della linea di galleggiamento per imbarcazioni in alluminio, vetroresina, legno compensato, acciaio e per altre parti in metallo o leghe leggere come assi, aliche e piedi poppieri.

«LIGHT PRIMER»

Epoxy two-component primer to be used for the upper and bottom parts of the waterline, suitable for alu, wood, fiberglass and steel boats and for all the steel or light alloys parts as shafts, propellers or sterndrive.

| Colore - Colour | Articolo - Item | Lt. | €/pc. | kg. | Articolo - Item | Lt. | €/pc. | kg. |
|------------------|-----------------|-------|-------|-------|-----------------|------|-------|-------|
| White 11630 | E 76 74 375 | 0,375 | | 0,500 | E 76 74 075 | 0,75 | | 1,000 |
| Grey-Beige 12170 | - | - | | - | E 76 79 075 | 0,75 | | 1,000 |



BICOMPONENTI | BI-COMPONENT

SUGGESTED ITEM



Art. E2950053
(pag. 405)

Art. E2950100
(pag. 405)



DILUENTI | DILUENTS «HEMPEL»

Diluyente per antivegetative autoleviganti e a matrice dura «THINNER 808»

Indicato per antivegetative acriliche, poliuretane ed alchidiche a spruzzo.

Diluent for self-polishing and hard antifouling «THINNER 808»

Suitable for acrylic, polyurethane and alkyd antifouling.

| Colore - Colour | Articolo - Item | Lt. | €/pc. | kg. |
|-------------------|-----------------|------|-------|-------|
| Transparent 00000 | E 77 01 075 | 0,75 | | 0,700 |



PER MONOCOMPONENTI | FOR MONO-COMPONENT



Diluyente per prodotti epossidici «THINNER 845»

Diluent for epoxy products «THINNER 845»

| Colore - Colour | Articolo - Item | Lt. | €/pc. | kg. |
|-------------------|-----------------|------|-------|-------|
| Transparent 00000 | E 77 02 075 | 0,75 | | 0,700 |



PER BICOMPONENTI | FOR BI-COMPONENT



STUCCHI | FILLERS «HEMPEL»

Stucco epossidico bicomponente «EPOXY FILLER»

Senza solventi, resistente all'acqua di mare, agli idrocarburi alifatici e ai suoi derivati. Per la riparazione dei danni osmotici in imbarcazioni in vetroresina.

Epoxy filler bi-component «EPOXY FILLER»

Without solvents, salt water and hydrocarbons resistant. Suitable for osmotic damages for fiberglass boats.

| Colore - Colour | Articolo - Item | Lt. | €/pc. | kg. |
|------------------|-----------------|------|-------|-------|
| Light-Grey 19810 | E 79 79 013 | 0,13 | | 0,700 |



SUGGESTED ITEM



Art. E3900151
(pag. 405)



Antiruggine spray

Fondo antiruggine con ottima adesività per applicazioni prima della verniciatura di motori marini o di altre parti metalliche.

Antirust spray

Excellent adhesion corrosion resistant layer. To be applied before painting of marine engines and other metallic parts.

| Articolo - Item | €/pc. | Contenitore-Container | Colore-Colour |
|-----------------|-------|-----------------------|---------------|
| E 39 40 090 | | Spray 400 ml. | Verde-Green |
| E 39 40 099 | | Spray 400 ml. | Grigio-Grey |



Vernici spray per motori

Vernici spray a rapida essiccazione approvata dalle case costruttrici per il ritocco e la verniciatura di motori marini.
Confezione in bombolette da 400 ml.

Engine spray varnishes

Fast drying spray varnishes approved by the engine's manufacturers for marine engines retouching and painting.
400 ml spray cans.

| Articolo - Item | €/pc. | Contenitore-Container | Mod. |
|-----------------|-------|------------------------|---------------------------------------|
| E 39 40 204 | | Bombolella-Can 400 ml. | BIANCO Selva "Pure WHITE" |
| E 39 40 050 | | Bombolella-Can 400 ml. | BLU Yamaha "Ocean BLUE" |
| E 39 40 051 | | Bombolella-Can 400 ml. | BLU Yamaha "Marine BLUE 84" |
| E 39 40 052 | | Bombolella-Can 400 ml. | NERO Mercury "BLACK" |
| E 39 40 053 | | Bombolella-Can 400 ml. | GRIGIO Mariner "GREY" |
| E 39 40 054 | | Bombolella-Can 400 ml. | GRIGIO CHIARO Mariner "Light GREY" |
| E 39 40 055 | | Bombolella-Can 400 ml. | BIANCO Evinrude-Johnson "White 71/80" |
| E 39 40 056 | | Bombolella-Can 400 ml. | BIANCO Johnson "WHITE 81/83" |
| E 39 40 058 | | Bombolella-Can 400 ml. | GRIGIO Johnson "GREY" |
| E 39 40 060 | | Bombolella-Can 400 ml. | BIANCO Iveco "WHITE" |
| E 39 40 063 | | Bombolella-Can 400 ml. | BLU Evinrude "BLUE XP" |
| E 39 40 064 | | Bombolella-Can 400 ml. | NERO Parsun "BLACK Met" |
| E 39 40 066 | | Bombolella-Can 400 ml. | GRIGIO Suzuki "GREY" |
| E 39 40 068 | | Bombolella-Can 400 ml. | NERO Suzuki "BLACK Metal" |
| E 39 40 069 | | Bombolella-Can 400 ml. | BIANCO Caterpillar "WHITE" |
| E 39 40 071 | | Bombolella-Can 400 ml. | BLU Selva "BLUE Metal" |
| E 39 40 075 | | Bombolella-Can 400 ml. | GRIGIO Honda "GREY Metal" |
| E 39 40 077 | | Bombolella-Can 400 ml. | GRIGIO Tohatsu "SILVER GREY" |
| E 39 40 080 | | Bombolella-Can 400 ml. | BLU Aifo Marine "BLUE" |
| E 39 40 081 | | Bombolella-Can 400 ml. | ROSSO Aifo Marine "Red" |
| E 39 40 083 | | Bombolella-Can 400 ml. | GRIGIO Yanmar "GREY" |
| E 39 40 085 | | Bombolella-Can 400 ml. | VERDE Volvo Penta "Green" |
| E 39 40 086 | | Bombolella-Can 400 ml. | GRIGIO Volvo Penta "Aquamatic" |
| E 39 40 088 | | Bombolella-Can 400 ml. | ROSSO Volvo Penta "Red" |
| E 39 40 091 | | Bombolella-Can 400 ml. | NERO OPACO "BLACK Mat" |
| E 39 40 092 | | Bombolella-Can 400 ml. | Lacca TRASPARENTE "Transparent" |
| E 39 40 093 | | Bombolella-Can 400 ml. | GRIGIO Volvo Penta "Aquamatic 89" |
| E 39 40 095 | | Bombolella-Can 400 ml. | BLU Nanni "BLUE Metal" |
| E 39 40 096 | | Bombolella-Can 400 ml. | GIALLO Caterpillar "Yellow" |
| E 39 40 098 | | Bombolella-Can 400 ml. | GRIGIO Yamaha "GREY Metal 94" |
| E 39 40 067 | | Bombolella-Can 400 ml. | GRIGIO Suzuki "GREY 89" |



Kit rullo e vaschetta

Completo di 1 rullo piatto.

| Articolo - Item | €/Kit | Lunghezza-Length mm. | kg. |
|-----------------|-------|----------------------|-------|
| E 29 02 100 | | 100 | 0,180 |

madeby 



Kit roller and bin

With 1 flat roller.

Ricambi per rulli

Spare parts for rollers

| Articolo - Item | €/pc. | Lunghezza Length mm. | Mod. | kg. |
|-----------------|-------|----------------------|-----------------------------------|-------|
| E 29 50 051 | | 100 | pelo lungo-long hair | 0,010 |
| E 29 50 053 | | 100 | pelo corto-short hair | 0,010 |
| E 29 50 052 | | 100 | pelo folto-deep hair | 0,010 |
| E 29 50 100 | | 100 | maniglia di ricambio-Spare handle | 0,080 |
| E 29 50 180 | | 180 | maniglia di ricambio-Spare handle | 0,120 |

madeby 



E2950051



E2950053



E2950052



E2950100



E2950180

Pennello tondo

Ideale per angoli.

| Articolo - Item | €/pc. | Lunghezza-Length mm. | kg. |
|-----------------|-------|----------------------|-------|
| E 29 50 425 | | 25 | 0,040 |
| E 29 50 430 | | 30 | 0,070 |

madeby 



Round brush

Very good for angles.

Pennello a setole chiare per applicazione di smalti e vernici

In pura setola chiara.

Flat brush for enamels and paints

Bright bristles.

| Articolo - Item | €/pc. | Lunghezza-Length mm. | kg. |
|-----------------|-------|----------------------|-------|
| E 29 50 320 | | 20 | 0,040 |
| E 29 50 330 | | 30 | 0,050 |
| E 29 50 340 | | 40 | 0,050 |
| E 29 50 350 | | 50 | 0,070 |

madeby 



Pennello di alta qualità a setole scure

High quality brush, dark bristle

| Articolo - Item | €/pc. | Lunghezza Length mm. | kg. |
|-----------------|-------|----------------------|-------|
| E 29 50 538 | | 38 | 0,070 |
| E 29 50 550 | | 50 | 0,130 |
| E 29 50 563 | | 63 | 0,170 |

madeby 



Pennello radiatore

Radiator brush

| Articolo - Item | €/pc. | Lunghezza Length mm. | kg. |
|-----------------|-------|----------------------|-------|
| E 29 50 250 | | 50x10 | 0,060 |

madeby 



Rullo alluminio frangibolla

Aluminium roller

| Articolo - Item | €/pc. | Lunghezza Length mm. | kg. |
|-----------------|-------|----------------------|-------|
| E 29 50 714 | | 150 | 0,180 |

madeby 



QOV

CONTENITORI DOCCIA E ACQUA | SHOWER BOXES & HOSES



RAL 9003

RAL 9010

Box doccia con rubinetto miscelatore

Rubinetto in ottone cromato con miscelatore in ceramica, vano di alloggiamento ad incasso bianco in ASA UV resistente.

Shower box with mixer

Chromed brass tap with ceramic mixer. Recess-fit white UV-resistant ASA housing.

| Articolo - Item Bianco-White 9003 N 01 74 411 | Articolo - Item VTR 9010 N 01 70 411 | €/kit. | Incasso Recess mm. Ø70x35 | Ingombro esterno Outer size Ø mm. 98 | Miscelatore Mixer N0102411 | Attacchi Fittings 3/8" Male |
|---|--|--------|---------------------------------|--|----------------------------------|-----------------------------------|
|---|--|--------|---------------------------------|--|----------------------------------|-----------------------------------|

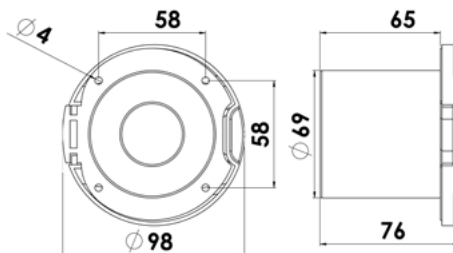

COMPLETO DI-COMLETE WITH



RAL 9003

RAL 9010

Box doccia con innesto rapido carico acqua

Attacco in ottone cromato con riduttore di pressione, vano di alloggiamento ad incasso bianco in ASA UV resistente.

Shower box with quick release water fitting

Chromed brass fitting with pressure reducer. Recess-fit white UV-resistant ASA housing.

| Articolo - Item Bianco-White 9003 N 01 74 066 | Articolo - Item VTR 9010 N 01 33 066 | €/kit. | Incasso Recess mm. Ø70x35 | Ingombro esterno Outer size Ø mm. 98 | Attacchi Fittings 3/4" Male |
|---|--|--------|---------------------------------|--|-----------------------------------|
|---|--|--------|---------------------------------|--|-----------------------------------|

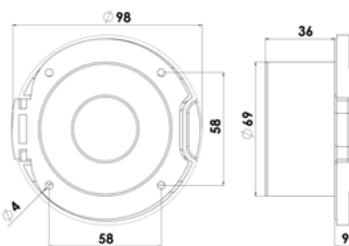

COMPLETO DI-COMLETE WITH



RAL 9003

RAL 9010

Box doccia con innesto rapido uscita acqua

Attacco in ottone cromato, vano di alloggiamento ad incasso bianco in ASA UV resistente.

Shower box with quick release water way out

Chromed brass fitting. Recess-fit white UV-resistant ASA housing.

| Articolo - Item Bianco-White 9003 N 01 74 065 | Articolo - Item VTR 9010 N 01 33 065 | €/kit. | Incasso Recess mm. Ø70x35 | Ingombro esterno Outer size Ø mm. 98 | Attacchi Fittings 3/4" Male |
|---|--|--------|---------------------------------|--|-----------------------------------|
|---|--|--------|---------------------------------|--|-----------------------------------|

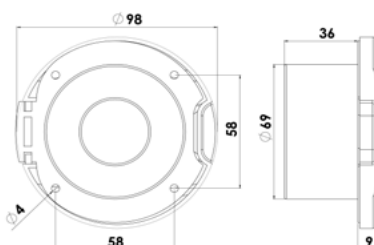

COMPLETO DI-COMLETE WITH



CONTENITORI DOCCIA E ACQUA | SHOWER BOXES & HOSES

Box doccia con doccia a pulsante e miscelatore

Doccia in plastica, vano di alloggiamento in ASA UV resistente. Completo di miscelatore acqua calda e fredda. Montaggio preferibilmente a parete.

Shower box with push-button shower & mixer

Plastic shower. Recess-fit UV-resistant ASA housing. Complete with hot & cold water mixer. Suitable for wall mounting.

| Articolo - Item | €/kit. | Dim.-Size mm. (Esterno-Outer) | Dim.-Size mm. (Interno-Inner) | Tubo in Hose made of | Tubo-Hose mt. |
|-----------------|--------|-------------------------------|-------------------------------|----------------------|---------------|
| N 01 05 250 | | 230x150 | 80x105 | PVC retinato | 2,5 |

madeby

COMPLETO DI-COMLETE WITH



Box doccia con doccia a pulsante

Vano di alloggiamento in ASA UV resistente. Montaggio a parete.

Shower box with push-button shower

Recess-fit UV-resistant ASA housing. Suitable for wall mounting.

| Articolo - Item | €/kit. | Dim.-Size mm. (Esterno-Outer) | Dim.-Size mm. (Interno-Inner) | Tubo-Hose mt. |
|-----------------|--------|-------------------------------|-------------------------------|---------------|
| N 01 04 250 | | 230x150 | 80x105 | 2,5 |

madeby

COMPLETO DI-COMLETE WITH



Kit tubo doccia

Doccia a levetta in plastica. Per installazioni in coperta.

Shower hose kit

Plastic lever-operated shower head. Deck fitting.

| Articolo - Item | €/kit. | Tubo-Hose mt. | Tubo-Hose | Supporto da coperta in ottone cromato Chromed brass deck support |
|-----------------|--------|---------------|-----------|---|
| N 01 38 257 | | 2,5 | N0100258 | NO |
| N 01 38 250 | | 2,5 | N0100250 | SI-YES |

madeby

COMPLETO DI-COMLETE WITH



Box completo di innesto rapido

Vano di alloggiamento ad incasso bianco in ASA UV resistente.

Box with quick coupling device

Recess-fit white UV-resistant ASA housing.

| Articolo - Item | €/pc. | Incasso Recess mm. | Ingombro esterno Outer size Ø mm. | Attacchi Fittings |
|-----------------|-------|--------------------|-----------------------------------|-------------------|
| N 01 70 412 | | Ø70x30H | 98 | 3/8" Male |

madeby

COMPLETE WITH

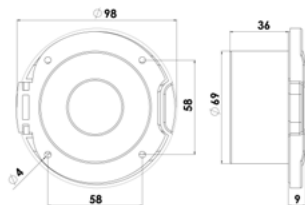

Box completo di innesto rapido e tubo doccia

Vano di alloggiamento ad incasso bianco in ASA UV resistente.

Box with quick coupling device & shower hose

Recess-fit white UV-resistant ASA housing.

| Articolo - Item | €/pc. | Incasso Recess mm. | Ingombro est. Outer size Ø mm. | Tubo-Hose mt. | Doccia ricambio Spare shower |
|-----------------|-------|--------------------|--------------------------------|---------------|------------------------------|
| N 01 03 412 | | Ø70x30H | 98 | 2,50 | N0110462 |

madeby

COMPLETO DI-COMLETE WITH

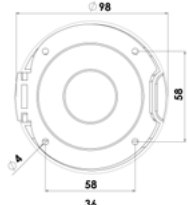
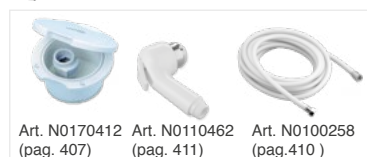

NOVA

CONTENITORI DOCCIA E ACQUA | SHOWER BOXES & HOSES



N0170251

Box doccia con doccia a pulsante

Doccia in plastica, vano di alloggiamento bianco in ASA UV resistente.

Shower box with push-button shower

Plastic shower. Recess-fit white UV-resistant ASA housing.

| Articolo - Item Bianco-White 9003 | Articolo - Item VTR 9010 | €/kit. | Incasso Recess mm. | Ingombro esterno Outer size Ø mm. | Tubo in Hose made of | Tubo-Hose mt. |
|-----------------------------------|--------------------------|--------|--------------------|-----------------------------------|----------------------|---------------|
| N 01 70 251 | N 01 70 250 | | Ø70 | 98 | PVC retinato | 2,50 |
| N 01 70 401 | N 01 70 400 | | Ø70 | 98 | PVC retinato | 4,00 |

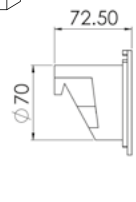

COMPLETO DI-COMLETE WITH



RAL 9003 Art. N0100073 (pag. 412) | RAL 9010 Art. N0100070 (pag. 412) | Art. N0125038 (pag. 411) | Art. N0100250 Art. N0100400 (pag. 410)



N0133250

Box doccia con doccia a pulsante

Doccia in ottone cromato, vano di alloggiamento bianco in ASA UV resistente.

Shower box with push-button shower

Chromed brass shower. Recess-fit white UV-resistant ASA housing.

| Articolo - Item Bianco-White 9003 | Articolo - Item Box VTR 9010 | €/kit. | Articolo - Item BoxAisi 316 | €/kit. | Incasso Recess mm. | Attacco Fitting | Tubo Hose | Tubo Hose mt. |
|-----------------------------------|------------------------------|--------|-----------------------------|--------|--------------------|-----------------|--------------|---------------|
| N 01 33 250 | N 01 68 250 | | N 01 38 250 | | Ø70 | 1/2" F | PVC retinato | 2,50 |
| N 01 33 400 | N 01 68 400 | | N 01 38 400 | | Ø70 | 1/2" F | PVC retinato | 4,00 |

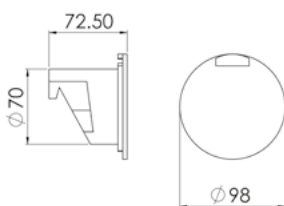

COMPLETO DI-COMLETE WITH

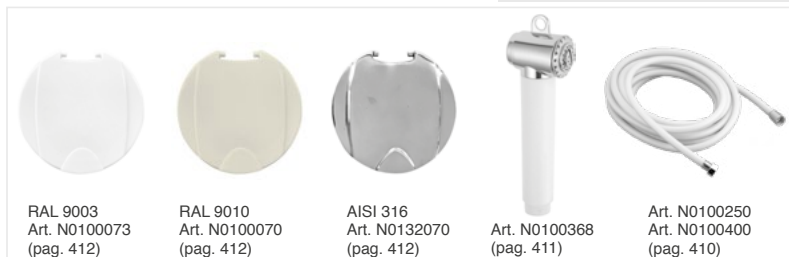

RAL 9003 Art. N0100073 (pag. 412) | RAL 9010 Art. N0100070 (pag. 412) | AISI 316 Art. N0132070 (pag. 412) | Art. N0100368 (pag. 411) | Art. N0100250 Art. N0100400 (pag. 410)



N0132258

Box doccia con doccia a levetta

Doccia in ottone cromato, vano di alloggiamento bianco in ASA UV resistente.

Shower box with lever shower

Chromed brass shower. Recess-fit white UV-resistant ASA housing.

| Articolo - Item Bianco-White 9003 | Articolo - Item Box VTR 9010 | €/kit. | Articolo - Item BoxAisi 316 | €/kit. | Incasso Recess mm. | Attacco Fitting | Tubo Hose | Tubo Hose mt. |
|-----------------------------------|------------------------------|--------|-----------------------------|--------|--------------------|-----------------|--------------|---------------|
| N 01 03 258 | N 01 10 258 | | N 01 32 258 | | Ø70 | 1/2" F | PVC retinato | 2,50 |
| N 01 03 408 | N 01 10 408 | | N 01 32 408 | | Ø70 | 1/2" F | PVC retinato | 4,00 |

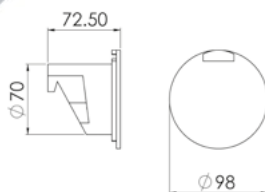

COMPLETO DI-COMLETE WITH

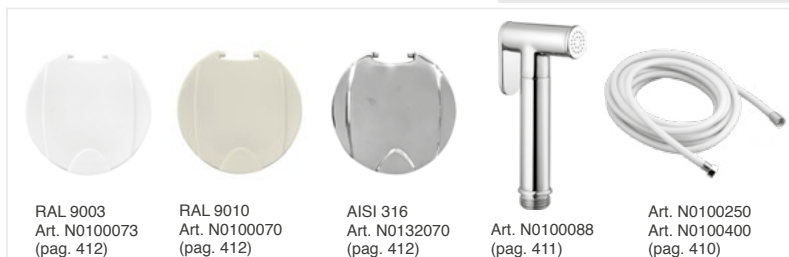

RAL 9003 Art. N0100073 (pag. 412) | RAL 9010 Art. N0100070 (pag. 412) | AISI 316 Art. N0132070 (pag. 412) | Art. N0100088 (pag. 411) | Art. N0100250 Art. N0100400 (pag. 410)



Box doccia con doccia a pulsante

Doccia in plastica, vano di alloggiamento bianco in ASA UV resistente.

Shower box with push-button shower

Plastic shower. Recess-fit white UV-resistant ASA housing.

| Articolo - Item Bianco-White 9003 | €/kit. | Incasso Recess mm. | Ingombro est. Outer size mm. | Tubo Hose | Tubo Hose mt. |
|-----------------------------------|--------|--------------------|------------------------------|--------------|---------------|
| N 01 95 250 | | 64x70 | 87x96 | PVC retinato | 2,50 |
| N 01 95 400 | | 64x70 | 87x96 | PVC retinato | 4,00 |

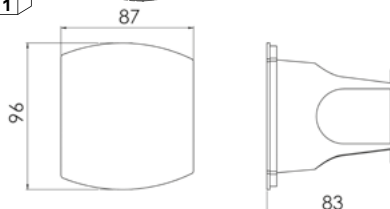

COMPLETO DI-COMLETE WITH



Art. N0195000 (pag. 412) | Art. N0125038 (pag. 411) | Art. N0100250 Art. N0100400 (pag. 410)

CONTENITORI DOCCIA E ACQUA | SHOWER BOXES & HOSES

Box doccia ovale con miscelatore e doccia a pulsante

Doccia in plastica, vano di alloggiamento bianco in ASA UV resistente. Completo di rubinetto miscelatore acqua calda/fredda. Montaggio in piano o a parete.

| Articolo - Item box | €/kit. | Incasso Recess mm. | Ingombro esterno Outer size mm. | Attacchi Fittings | Tubo in Hose made of | Tubo-Hose mt. |
|---------------------|--------|-----------------------|------------------------------------|----------------------|-------------------------|------------------|
| Bianco-White 9003 | | | | | | |
| N 01 18 250 | | 145x72 | 185x110 | 3/8" Male | PVC retinato | 2,50 |
| N 01 18 401 | | 145x72 | 185x110 | 3/8" Male | PVC retinato | 4,00 |



COMPLETO DI-COMPLETE WITH



Art. N0125038
(pag. 411)

Art. N0195180
(pag. 412)

Art. N0102411
(pag. 413)

Art. N0100258
Art. N0100408
(pag. 410)

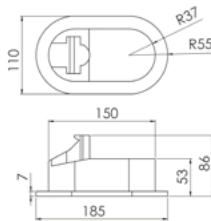

Box doccia ovale con miscelatore e doccia a pulsante

Doccia in plastica cromata, vano di alloggiamento bianco in ASA UV resistente. Completo di rubinetto miscelatore acqua calda/fredda. Montaggio in piano o a parete.

| Articolo - Item box | €/kit. | Incasso Recess mm. | Ingombro esterno Outer size mm. | Attacchi Fittings | Tubo in Hose made of | Tubo-Hose mt. |
|---------------------|--------|-----------------------|------------------------------------|----------------------|-------------------------|------------------|
| Bianco-White 9003 | | | | | | |
| N 01 18 258 | | 145x72 | 185x110 | 3/8" Male | PVC retinato | 2,50 |
| N 01 18 408 | | 145x72 | 185x110 | 3/8" Male | PVC retinato | 4,00 |

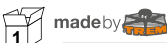

COMPLETO DI-COMPLETE WITH

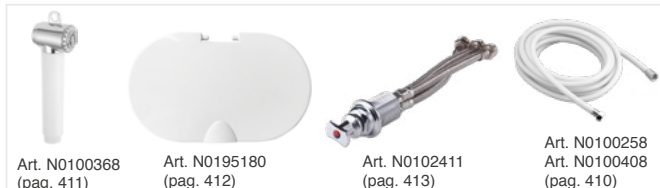

Art. N0100368
(pag. 411)

Art. N0195180
(pag. 412)

Art. N0102411
(pag. 413)

Art. N0100258
Art. N0100408
(pag. 410)

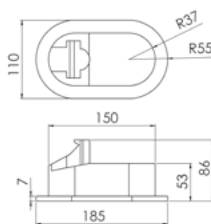

Box doccia ovale con miscelatore e doccia a pulsante

Doccia in ottone cromato, vano di alloggiamento bianco in ASA UV resistente. Completo di rubinetto miscelatore acqua calda/fredda. Montaggio in piano o a parete.

| Articolo - Item box | €/kit. | Incasso Recess mm. | Ingombro esterno Outer size mm. | Attacchi Fittings | Tubo in Hose made of | Tubo-Hose mt. |
|---------------------|--------|-----------------------|------------------------------------|----------------------|-------------------------|------------------|
| Bianco-White 9003 | | | | | | |
| N 01 18 252 | | 145x72 | 185x110 | 3/8" Male | PVC retinato | 2,50 |
| N 01 18 402 | | 145x72 | 185x110 | 3/8" Male | PVC retinato | 4,00 |



COMPLETO DI-COMPLETE WITH



Art. N0110462
(pag. 411)

Art. N0195180
(pag. 412)

Art. N0102411
(pag. 413)

Art. N0100258
Art. N0100408
(pag. 410)

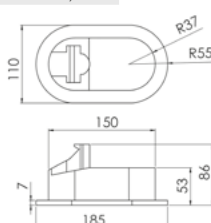

Box doccia ovale con miscelatore e doccia a pulsante

Doccia in ottone cromato, vano di alloggiamento bianco in ASA UV resistente. Completo di rubinetto miscelatore acqua calda/fredda. Montaggio in piano o a parete.

| Articolo - Item box | €/kit. | Incasso Recess mm. | Ingombro esterno Outer size mm. | Attacchi Fittings | Tubo in Hose made of | Tubo-Hose mt. |
|---------------------|--------|-----------------------|------------------------------------|----------------------|-------------------------|------------------|
| Bianco-White 9003 | | | | | | |
| N 01 28 258 | | 145x72 | 185x110 | 3/8" Male | PVC retinato | 2,50 |
| N 01 28 408 | | 145x72 | 185x110 | 3/8" Male | PVC retinato | 4,00 |



NEW

COMPLETO DI-COMPLETE WITH

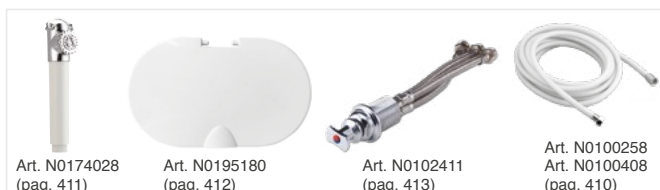

Art. N0174028
(pag. 411)

Art. N0195180
(pag. 412)

Art. N0102411
(pag. 413)

Art. N0100258
Art. N0100408
(pag. 410)

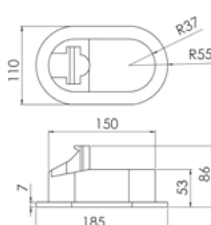

QOV

TUBI DOCCIA | SHOWER HOSES

Tube doccia retinato in PVC Net PVC shower hose

| Articolo - Item | €/pc. | Lunghezza Length mt. | Raccordi terminali Terminal fittings |
|-----------------|-------|-------------------------|---|
| N 01 00 250 | | 2,50 | 1/2" Female-1/2" Female |
| N 01 00 400 | | 4,00 | 1/2" Female-1/2" Female |
| N 01 00 600 | | 6,00 | 1/2" Female-1/2" Female |



Tube doccia retinato in PVC Net PVC shower hose

| Articolo - Item | €/pc. | Lunghezza Length mt. | Raccordi terminali Terminal fittings |
|-----------------|-------|-------------------------|---|
| N 01 00 258 | | 2,50 | 3/8" Female-1/2" Female |
| N 01 00 408 | | 4,00 | 3/8" Female-1/2" Female |



SUGGESTED ITEM



Art. N0132060
(pag. 413)

Tube doccia retinato in PVC Net PVC shower hose

| Articolo - Item | €/pc. | Lunghezza Length mt. | Raccordi terminali Terminal fittings |
|-----------------|-------|-------------------------|---|
| N 01 12 250 | | 2,50 | 1/2" Female-3/8" Male |



SUGGESTED ITEM



Art. N0112241
(pag. 413)

Tube flessibile in ottone Brass flexible hose

| Articolo - Item | €/pc. | Lunghezza Length mt. | Raccordi terminali Terminal fittings |
|-----------------|-------|-------------------------|---|
| N 01 25 034 | | 2,50 | 1/2" Female-1/2" Female |



Tube flessibile in ottone Brass flexible hose

| Articolo - Item | €/pc. | Lunghezza Length mt. | Raccordi terminali Terminal fittings |
|-----------------|-------|-------------------------|---|
| N 01 12 034 | | 1,20 | 15/1" Male-1/2" Female |
| N 01 12 152 | | 1,50 | 15/1" Male-1/2" Female |
| N 01 12 252 | | 2,50 | 15/1" Male-1/2" Female |



NEW



SUGGESTED ITEM



Art. N0133060
(pag. 413)

Tube doccia retinato grigio in Nylon nylon grey shower hose

| Articolo - Item | €/pc. | Lunghezza Length mt. | Raccordi terminali Terminal fittings |
|-----------------|-------|-------------------------|---|
| N 01 14 250 | | 2,50 | 1/2" Female-15/1" Male |



NEW



SUGGESTED ITEM



Art. N0133060
(pag. 413)

Tube doccia retinato grigio in Nylon nylon grey shower hose

Fabbricato in Nylon con interno in EPDM. Manufactured in Nylon with EPDM core.

| Articolo - Item | €/pc. | Lunghezza Length mt. | Raccordi terminali Terminal fittings |
|-----------------|-------|-------------------------|---|
| N 01 38 015 | | 1,50 | 3/8" Female-15/1" Male |



NEW



SUGGESTED ITEM



Art. N0133060
(pag. 413)

DOCCETTA | SHOWERS

Doccetta Shower

Fabbricata in Polipropilene. Manufactured in Polypropylene.

| Articolo - Item | €/pc. | Colore Colour | Attacco Fitting |
|-----------------|-------|---------------------------------------|-----------------|
| N 01 25 038 | | <input type="checkbox"/> Bianco-White | 1/2" Male |



SUGGESTED ITEM

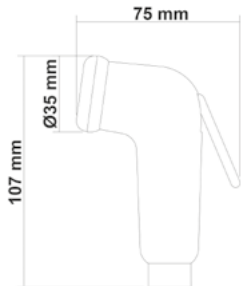

Doccetta Shower

Fabbricata in ABS. Manufactured in ABS.

| Articolo - Item | €/pc. | Colore Colour | Attacco Fitting |
|-----------------|-------|--|-----------------|
| N 01 25 110 | | <input type="checkbox"/> Bianco-White | 1/2" Male |
| N 01 79 110 | | <input type="checkbox"/> White-Chromed | 1/2" Male |



NEW

SUGGESTED ITEM



Doccetta Shower

Fabbricata in ABS e ottone. Manufactured in ABS & brass.

| Articolo - Item | €/pc. | Attacco Fitting |
|-----------------|-------|-----------------|
| N 01 00 368 | | 1/2" Male |



SUGGESTED ITEM

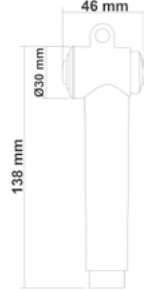

Doccetta Shower

Fabbricata in ABS e ottone. Manufactured in ABS & brass.

| Articolo - Item | €/pc. | Attacco Fitting |
|-----------------|-------|-----------------|
| N 01 74 028 | | 1/2" Male |



NEW

SUGGESTED ITEM



Doccetta Shower

Fabbricata in ottone. Manufactured in brass.

| Articolo - Item | €/pc. | Attacco Fitting |
|-----------------|-------|-----------------|
| N 01 00 086 | | 1/2" Male |



NEW

SUGGESTED ITEM

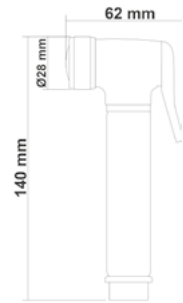

Doccetta Shower

Fabbricata in ottone. Manufactured in brass.

| Articolo - Item | €/pc. | Attacco Fitting |
|-----------------|-------|-----------------|
| N 01 00 088 | | 1/2" Male |



NEW

SUGGESTED ITEM

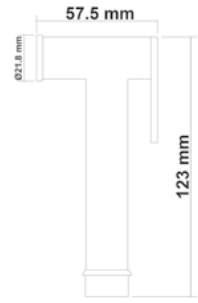

Doccetta Shower

Fabbricata in ABS. Manufactured in ABS.

| Articolo - Item | €/pc. | Colore Colour | Attacco Fitting |
|-----------------|-------|-----------------------------------|-----------------|
| N 01 05 462 | | <input type="checkbox"/> Ral 9003 | 1/2" Male |
| N 01 10 462 | | <input type="checkbox"/> Ral 9010 | 1/2" Male |



SUGGESTED ITEM



Doccetta con attacco Shower with fitting

| Articolo - Item | €/pc. | Attacco Fitting |
|-----------------|-------|-----------------|
| N 01 01 462 | | 1/2" Male |



SUGGESTED ITEM



Doccetta con attacco Shower with fitting

| Articolo - Item | €/pc. | Attacco Fitting |
|-----------------|-------|-----------------|
| N 01 33 462 | | 15/1" Female |



SUGGESTED ITEM

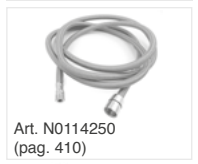

QOV

CONTENITORI PER DOCCETTE | SHOWER BOXES

Contentore doccia tondo

Round shower box

Fabbricato in ASA

Manufactured in ASA..

| Articolo - Item | €/pc. | Corpo-Body |
|-----------------|-------|-----------------|
| N 01 00 070 | | Ral 9010 |
| N 01 79 070 | | Cromato-Chromed |
| N 01 00 073 | | Ral 9003 |

madeby



Contentore doccia tondo

Round shower box

Fabbricato in Aisi316

Manufactured in AISI 316.

| Articolo - Item | €/pc. | Corpo-Body |
|-----------------|-------|------------|
| N 01 32 070 | | Aisi 316 |

madeby **NEW**



Contentore doccia ovale

Oval shower box

Fabbricato in ASA.

Manufactured in ASA.

| Articolo - Item | €/pc. | mm. | Colore-Colour |
|-----------------|-------|--------|---------------|
| N 01 95 180 | | 150x75 | Ral 9003 |

madeby

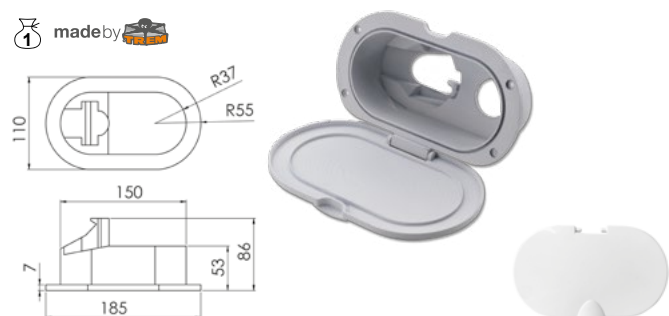

Contentore mixer

Mixer case

Fabbricato in ASA.

Manufactured in ASA.

| Articolo - Item | €/pc. | mm. | Colore-Colour |
|-----------------|-------|-----|-----------------|
| N 01 70 063 | | 70 | Ral 9010 |
| N 01 74 063 | | 70 | Ral 9003 |
| N 01 70 079 | | 70 | Cromato-Chromed |

madeby



Contentore doccia ovale

Oval shower box

Fabbricato in ABS.

Manufactured in ABS.

| Articolo - Item | €/pc. | mm. | Colore-Colour |
|-----------------|-------|-------|---------------|
| N 01 95 074 | | 79x69 | Ral 9003 |

madeby

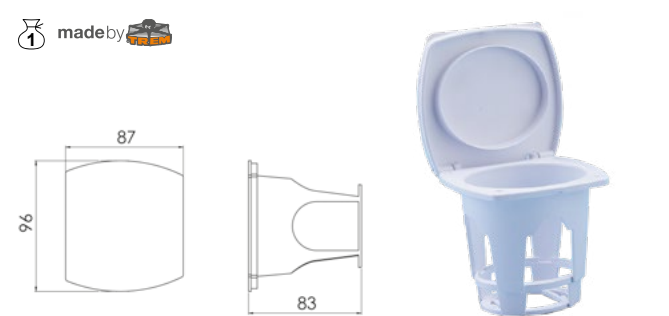

Contentore doccia tondo

Round shower box

Per motivi dimensionali si consiglia di utilizzare doccia N0100368.

For size reasons we suggest to use the shower art. N0100368.

| Articolo - Item | €/pc. | Incasso-Recess Ø mm. |
|-----------------|-------|----------------------|
| N 01 00 090 | | 56 |

madeby



DOCCETTE | SHOWERS

Contentore per acqua

Fabbricata in polietilene per alimenti. Pieghevole. Con rubinetto.

Folding water tank

Made of alimentary polyethylene. Folding. With tap.

| Articolo - Item | €/pc. | Capacità-Capacity Lt. | kg. |
|-----------------|-------|-----------------------|-------|
| N 01 20 002 | | 20 | 0,260 |

madeby



Doccia solare

Fabbricata in speciale PVC per ottenere acqua calda. Completa di tubo e doccia.

Solar shower

Manufactured in special PVC to get hot water. With shower and tube.

| Articolo - Item | €/pc. | Capacità-Capacity Lt. | kg. |
|-----------------|-------|-----------------------|-------|
| N 01 20 300 | | 20 | 0,330 |

madeby



ACCESSORI DOCCETTE | SHOWERS ACCESSORIES

Mixer

Realizzato in ottone cromato.

| Articolo - Item | €/pc. | Scasso-Recess Ø mm. | kg. |
|-----------------|-------|---------------------|-------|
| N 01 02 411 | | 32 | 0,460 |



M 3/8"

Mixer

Manufactured in chromed brass.

Kit innesto rapido

Fabbricato in materiale plastico. Ideale per contenitore N0170004.

| Articolo - Item | €/Kit | Kit | kg. |
|-----------------|-------|-----|-------|
| N 01 01 000 | | 10 | 0,020 |



M 3/8"

Quick-coupling spare part

Manufactured in plastic material. Suitable to be fitted in the case art. N0170004.

Supporto porta doccetta

In plastica antiurto.

| Articolo - Item | €/pc. | Mod. | pcs. |
|-----------------|-------|------------------|------|
| N 01 34 001 | | Ottone-Brass/ABS | 10 |



Shower support

In shockproof plastic.

Adattatore per tubi doccia da 3/8" a 1/2"

| Articolo - Item | €/pc. | Attacco-Fitting |
|-----------------|-------|-----------------|
| N 01 12 241 | | 3/8"-1/2" |



F 3/8"

M 1/2"

Shower hose adapter from 3/8" to 1/2"

Supporto curvo doppio femmina

Realizzato in ottone cromato. Filettatura 1/2" femmina e 15/1" femmina.

| Articolo - Item | €/pc. | pcs. |
|-----------------|-------|------|
| N 01 33 060 | | 10 |



F 15/1"

F 1/2"

Shower support

Manufactured in chromed brass. Threading 1/2" female 15/1" female.

Supporto curvo femmina e maschio

Realizzato in ottone cromato. Filettatura 1/2" femmina e 1/2" maschio.

| Articolo - Item | €/pc. | pcs. |
|-----------------|-------|------|
| N 01 32 060 | | 10 |



M 1/2"

F 1/2"

Shower support female & male

Made in chromed brass. Threading 1/2" female 1/2" male.

Innesto

Coupling

| Articolo - Item | €/pc. | Attacco Fitting |
|-----------------|-------|-----------------|
| N 01 20 060 | | 3/4" Female |



Innesto

Coupling

| Articolo - Item | €/pc. | Attacco Fitting |
|-----------------|-------|-----------------|
| N 01 20 045 | | 3/4" Female |



Riduttore pressione

Pressure reducer

| Articolo - Item | €/pc. | Attacco Fitting |
|-----------------|-------|-----------------------|
| N 01 25 075 | | 3/4" Female-3/4" Male |



NOVA

MISCELATORI E RUBINETTI | MIXERS & TAPS



Rubinetto acqua fredda canna bassa Cold water short tap

Fabbricato in ottone cromato.

Manufactured in chromed brass.

| Articolo - Item | €/pc. | maniglia-handle | Attacco-Fitting |
|-----------------|-------|-----------------|-------------------|
| N 01 15 130 | | DX | 3/8" Maschio-Male |

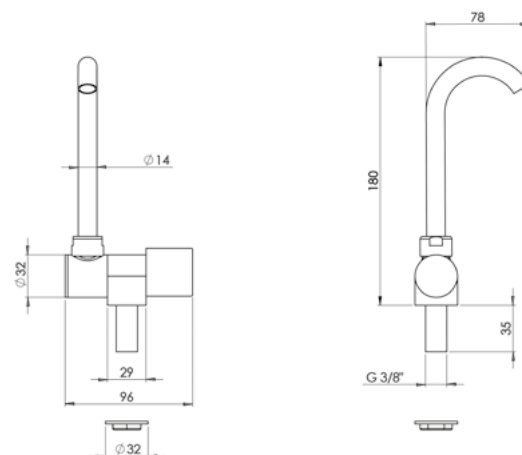

Rubinetto acqua fredda/calda canna bassa Hot/Cold water short tap

Fabbricato in ottone cromato.

Manufactured in chromed brass.

| Articolo - Item | €/pc. | Attacco-Fitting |
|-----------------|-------|----------------------|
| N 01 03 110 | | 2x 3/8" Maschio-Male |

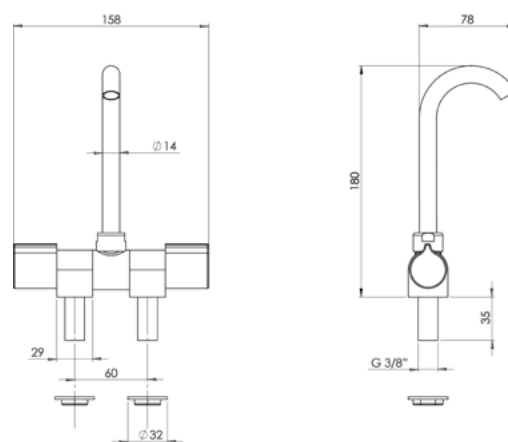

Rubinetto mixer canna bassa Short mixer tap

Fabbricato in ottone cromato.

Manufactured in chromed brass.

| Articolo - Item | €/pc. | maniglia-handle | Mixer in-made of | Attacco-Fitting |
|-----------------|-------|-----------------|-------------------|------------------------|
| N 01 18 038 | | DX | Ceramica-Ceramics | 2x 1/2" Femmina-Female |
| N 01 18 038S | | SX | Ceramica-Ceramics | 2x 1/2" Femmina-Female |

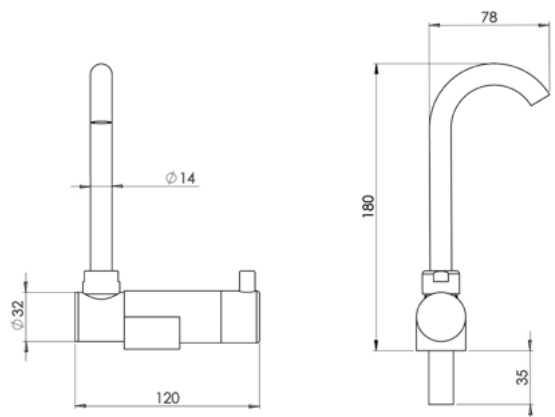

MISCELATORI E RUBINETTI | MIXERS & TAPS

Rubinetto acqua fredda/calda canna alta **Hot/Cold water long tap**

Fabbricato in ottone cromato.

Manufactured in chromed brass.

| Articolo - Item | €/pc. | Attacco-Fitting |
|-----------------|-------|----------------------|
| N 01 00 311 | | 2x 3/8" Maschio-Male |

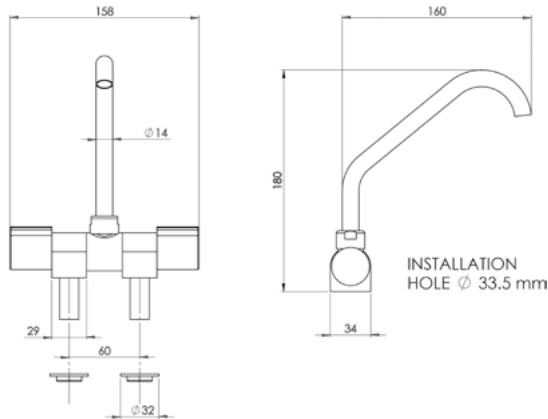

Rubinetto acqua fredda canna alta **Cold water long tap**

Fabbricato in ottone cromato.

Manufactured in chromed brass.

| Articolo - Item | €/pc. | maniglia-handle | Attacco-Fitting |
|-----------------|-------|-----------------|-------------------|
| N 01 00 315 | | DX | 3/8" Maschio-Male |

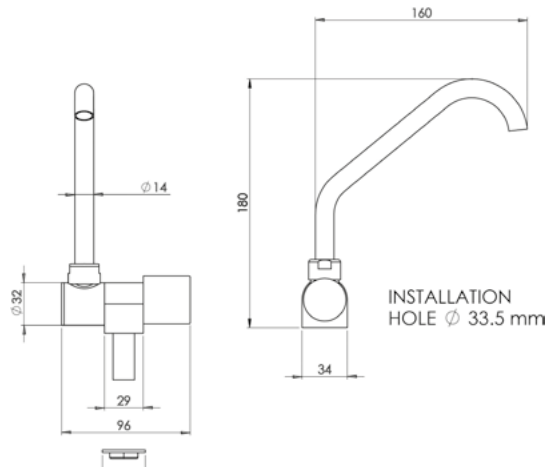

Rubinetto mixer canna alta **Long mixer tap**

Fabbricato in ottone cromato.

Manufactured in chromed brass.

| Articolo - Item | €/pc. | maniglia-handle | Mixer in-made of | Attacco-Fitting |
|-----------------|-------|-----------------|-------------------|------------------------|
| N 01 14 038 | | DX | Ceramica-Ceramics | 2x 1/2" Femmina-Female |

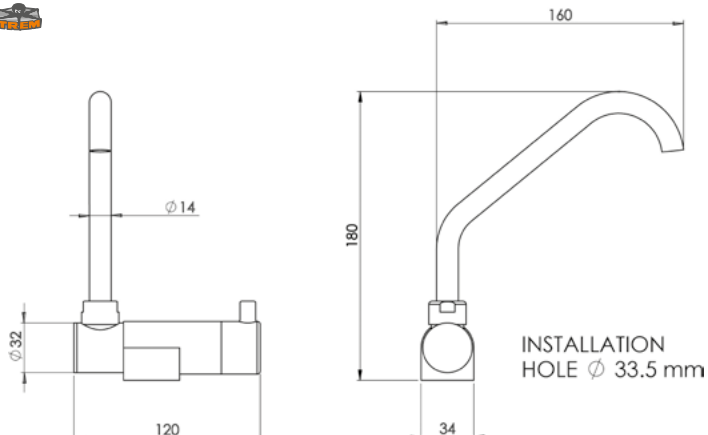

MISCELATORI E RUBINETTI | MIXERS & TAPS

Rubinetto abbattibile acqua fredda canna profonda

Fabbricato in ottone cromato.

Folding cold water tap

Manufactured in chromed brass.

| Articolo - Item | €/pc. | maniglia-handle | Attacco-Fitting |
|-----------------|-------|-----------------|-------------------|
| N 01 11 038 | | DX | 3/8" Maschio-Male |

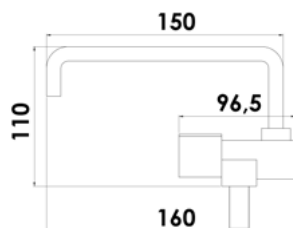

Rubinetto abbattibile acqua fredda/calda canna profonda

Fabbricato in ottone cromato.

Folding hot/cold water tap

Manufactured in chromed brass.

| Articolo - Item | €/pc. | Attacco-Fitting |
|-----------------|-------|----------------------|
| N 01 13 038 | | 2x 3/8" Maschio-Male |

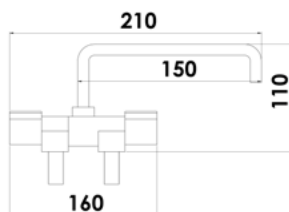

Rubinetto abbattibile mixer canna profonda

Fabbricato in ottone cromato.

Folding mixer tap

Manufactured in chromed brass.

| Articolo - Item | €/pc. | maniglia-handle | Mixer in-made of | Attacco-Fitting |
|-----------------|-------|-----------------|-------------------|------------------------|
| N 01 15 038 | | DX | Ceramica-Ceramics | 2x 1/2" Femmina-Female |

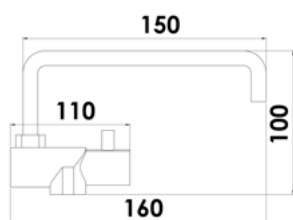

MISCELATORI E RUBINETTI | MIXERS & TAPS

Rubinetto acqua fredda canna piatta Cold water flat tap

Fabbricato in ottone cromato.

Manufactured in chromed brass.

| Articolo - Item | €/pc. | maniglia-handle | Attacco-Fitting |
|-----------------|-------|-----------------|-------------------|
| N 01 19 098 | | DX | 3/8" Maschio-Male |
| N 01 19 098S | | SX | 3/8" Maschio-Male |

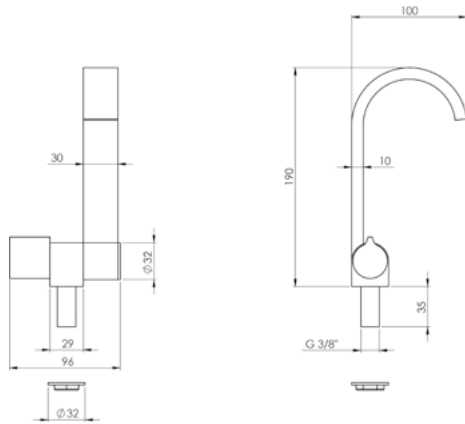

Rubinetto acqua fredda/calda canna piatta Hot/Cold water flat tap

Fabbricato in ottone cromato.

Manufactured in chromed brass.

| Articolo - Item | €/pc. | Attacco-Fitting |
|-----------------|-------|----------------------|
| N 01 19 160 | | 2x 3/8" Maschio-Male |

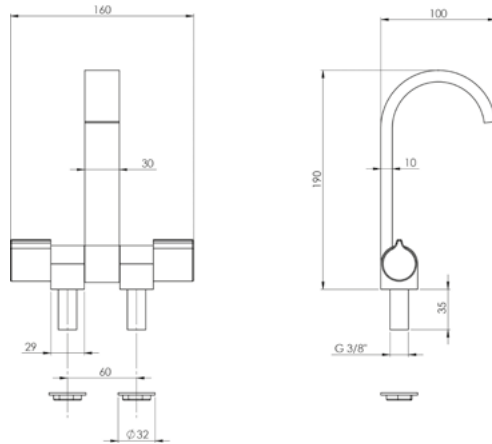

Rubinetto mixer canna piatta Flat mixer tap

Fabbricato in ottone cromato.

Manufactured in chromed brass.

| Articolo - Item | €/pc. | maniglia-handle | Mixer in-made of | Attacco-Fitting |
|-----------------|-------|-----------------|-------------------|------------------------|
| N 01 00 195 | | DX | Ceramica-Ceramics | 2x 1/2" Femmina-Female |

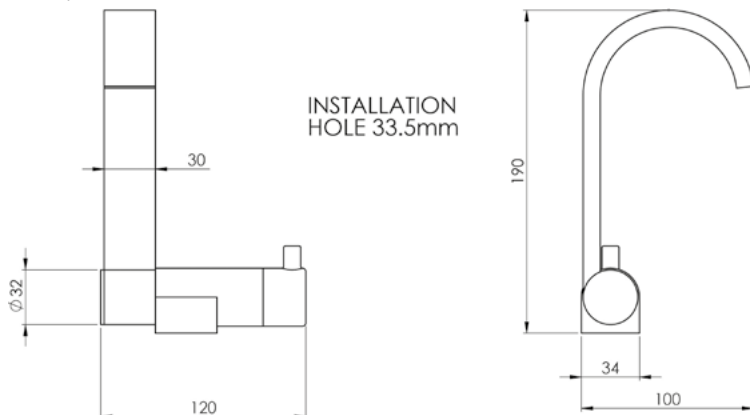

QOVA

MISCELATORI E RUBINETTI | MIXERS & TAPS



Miscelatore monocomando quadro

Fabbricato in ottone. Leva zincata.
Valvola 35 mm. in ceramica. Attacchi in acciaio inox.

Square single control mixer

Brass body and spout. Zinc handle. 35 mm. ceramics valve. Brass outlet with plastic filter. 40 cm S.S. wire braided hose. S.S. fittings.

| Articolo - Item | €/pc. | Attacco-Fitting | A mm. | B mm. | C mm. |
|-----------------|-------|------------------------|-------|-------|-------|
| N 01 12 200 | | 2x 1/2" Femmina-Female | 120 | 200 | 40 |

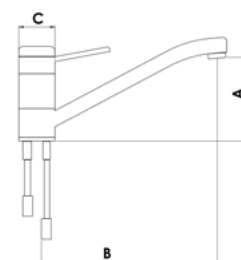

Miscelatore monocomando

Per lavello canna girevole.
Attacco 1/2" femmina.

Single control mixer

Swivelling mixer for sink.
Female connection 1/2".

| Articolo - Item | €/pc. | Attacco-Fitting | A mm. | B mm. | C mm. |
|-----------------|-------|------------------------|-------|-------|-------|
| N 01 14 201 | | 2x 1/2" Femmina-Female | 80 | 140 | 40 |
| N 01 20 201 | | 2x 1/2" Femmina-Female | 120 | 200 | 40 |

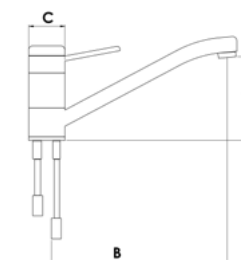

Monocomando miscelatore cromato + doccia estraibile cromata

Tubo flessibile in ottone cromato da 1,5 mt.

Shower faucet with flexible and mixer

Flexible hose in chromed brass 1,5 mt long.

| Articolo - Item | €/kit. | Attacco Fitting | Monocomando Lever Ø mm. |
|-----------------|--------|-----------------|-------------------------|
| N 01 02 251 | | 2x 1/2" Female | 40 |



SUGGESTED ITEM



Art. N0112152
Art. N0112252
(pag. 410)

COMPLETO DI-COMLETE WITH



Art. N0134251
(pag.420)

Art. N0112034
(pag. 410)

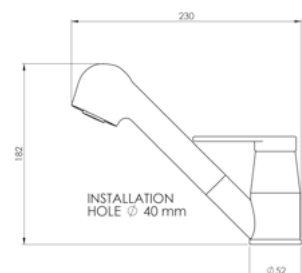

Miscelatore ceramico girevole per lavello cucina

Rubinetto in ottone cromato.

Rotating mixer tap for sink

Manufactured in chromed brass.

| Articolo - Item | €/pc. | Attacco-Fitting | A mm. | B mm. | C mm. | D mm. | E mm. |
|-----------------|-------|------------------------|-------|-------|-------|-------|-------|
| N 01 35 163 | | 2x 1/2" Femmina-Female | 55 | 162,5 | 350 | 248 | 200 |

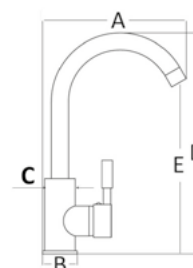

MISCELATORI E RUBINETTI | MIXERS & TAPS
Rubinetto con doccia estraibile

Fabbricato in ottone cromato. Completo di pomello caldo e freddo. Tubo da 1,5 mt.

Tap with removable shower

Manufactured in chromed brass. With hot/cold knob. Hose 1,5 mt.

| Articolo - Item | €/kit. | Sporgenza Protrusion mm. | H mm. | Tubo-Hose mt. | Attacco Fitting |
|-----------------|--------|-----------------------------|----------|------------------|--------------------|
| N 01 04 311 | | 180 | 150 | 1,5 | 3/8" Maschio-Male |

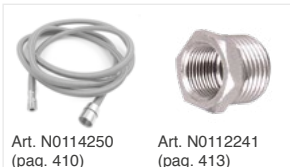
SUGGESTED ITEM

 Art. N0114250
(pag. 410)

 Art. N0112241
(pag. 413)

COMPLETO DI-COMLETE WITH

 Art. N0133462
(pag.411)

 N0138015 1,5 mt
(pag. 410)

Mixer con doccia estraibile

Fabbricato in ottone cromato. Cartuccia in ceramica.

Mixer with removable shower

Manufactured in chromed brass. With ceramic cartridge.

| Articolo - Item | €/kit. | Sporgenza Protrusion mm. | H mm. | Tubo-Hose mt. | Attacco Fitting |
|-----------------|--------|-----------------------------|----------|------------------|--------------------|
| N 01 15 150 | | 180 | 150 | 1,5 | 3/8" Maschio-Male |

SUGGESTED ITEM

 Art. N0114250
(pag. 410)

 Art. N0112241
(pag. 413)

COMPLETO DI-COMLETE WITH

 Art. N0133462
(pag.411)

 N0138015 1,5 mt
(pag. 410)

Rubinetti e mixer
Taps & mixers

| Articolo - Item | €/pc. | Mod. | H mm. | Attacco-Fitting |
|-----------------|-------|-----------------------------|-------|----------------------|
| N 01 00 210 | | Miscelatore-Mixer | 210 | 2x 3/8" Maschio-Male |
| N 01 01 212 | | Rubinetto sinistra-Left tap | 210 | 1x 3/8" Maschio-Male |
| N 01 02 212 | | Rubinetto destra-Right tap | 210 | 1x 3/8" Maschio-Male |



N0100210



N0101212



N0102212

QOVA

MISCELATORI E RUBINETTI | MIXERS & TAPS



Beccucci snodati per rubinetti

| Articolo - Item | €/pc. | Attacco-Fitting | kg. |
|-----------------|-------|---------------------|-------|
| N 01 15 205 | | 5/8" Maschio-Male | 0,050 |
| N 01 12 105 | | 1/2" Femmina-Female | 0,050 |



Water saver for taps

Doccia

| Articolo - Item | €/pc. | Attacco-Fitting |
|-----------------|-------|-------------------|
| N 01 34 251 | | 1/2" Maschio-Male |



Shower



AREA DIDATTICA | EDUCATIONAL AREA

A QUANTI POLLICI CORRISPONDE IL DIAMETRO DEL MIO ATTACCO? HOW MANY INCHES DOES THE DIAMETER OF MY CONNECTION MEET?

Sotto vi riportiamo una semplice tabella per poter interpretare a quanti pollici o millimetri corrisponde l'attacco del vostro mixer.
Below we present a simple table to interpret how many inches or millimeters your mixer connection is.

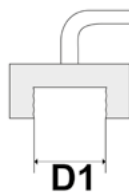

| DIAMETRO DEL TUBO-HOSE DIAMETER | | DIAMETRO DELLA FILETTATURA-THREAD DIAMETER | |
|---------------------------------|------------------------|--|---------------------|
| Pollici-Inches | Millimetri-Millimeters | Esterno-Outer D mm | Interno-Inner D1 mm |
| 1/8 | 3,17 | 9,73 | 8,57 |
| 1/4 | 6,35 | 13,16 | 11,45 |
| 3/8 | 9,52 | 16,66 | 14,95 |
| 1/2 | 12,7 | 20,96 | 18,63 |
| 5/8 | 15,87 | 22,91 | 20,59 |
| 3/4 | 19,05 | 26,44 | 24,12 |
| 7/8 | 22,23 | 30,20 | 27,88 |
| 1 | 25,40 | 33,25 | 30,29 |
| 1 1/8 | 28,57 | 37,90 | 34,94 |
| 1 1/4 | 31,75 | 41,91 | 38,95 |
| 1 3/8 | 34,92 | 44,32 | 41,37 |
| 1 1/2 | 38,10 | 47,80 | 44,85 |
| 1 3/4 | 44,45 | 53,75 | 50,79 |
| 2 | 50,80 | 59,61 | 56,66 |

Lavelli semisferici in acciaio inox

Round sinks in stainless steel

Lucidati a specchio.

Mirror polished. With drain cover.

| Articolo - Item | €/pc. | Ø mm. | Spessore Thickness mm. | kg. |
|-----------------|-------|---------------------|------------------------|-------|
| Z 08 32 026 | | int. 260 - ext. 295 | 0,6 | 0,420 |
| Z 08 32 030 | | int. 300 - ext. 335 | 0,8 | 0,900 |

I lavelli vengono sempre venduti privi di piletta
The sinks are always supplied without waste kit **made by**



Lavello ovale in acciaio inox

Oval sink in stainless steel

Lucidato a specchio.

Mirror polished. With drain cover.

| Articolo - Item | €/pc. | mm. (int.) | mm. (ext.) | H mm. | Spessore Thickness mm. |
|-----------------|-------|------------|------------|-------|------------------------|
| Z 08 24 375 | | 240x375 | 265x390 | 125 | 0,8 |

I lavelli vengono sempre venduti privi di piletta
The sinks are always supplied without waste kit **made by**



Lavelli tondi in acciaio inox

Round sinks in stainless steel

Lucidati a specchio.

Mirror polished. With drain cover.

| Articolo - Item | €/pc. | Ø mm. (int.) | Ø mm. (ext.) | H mm. | Spessore Thickness mm. |
|-----------------|-------|--------------|--------------|-------|------------------------|
| Z 08 29 000 | | 260 | 290 | 180 | 0,8 |
| Z 08 30 000 | | 300 | 325 | 180 | 0,8 |

I lavelli vengono sempre venduti privi di piletta
The sinks are always supplied without waste kit **made by**



Lavelli rettangolari in acciaio inox

Rectangular sinks in stainless steel

Lucidati a specchio.

Mirror polished. With drain cover.

| Articolo - Item | €/pc. | mm. (int.) | mm. (ext.) | H mm. | Spessore Thickness mm. |
|-----------------|-------|------------|------------|-------|------------------------|
| Z 08 15 300 | | 150x300 | 170x320 | 150 | 0,8 |
| Z 08 30 238 | | 238x300 | 260x325 | 150 | 0,8 |
| Z 08 30 330 | | 330x330 | 350x350 | 150 | 0,8 |

I lavelli vengono sempre venduti privi di piletta
The sinks are always supplied without waste kit



Piletta per lavelli

Per lavelli con uscite sia da 20mm che da 25mm, grazie al portagomma raccordato.

Sink waste kit

For sinks with 20mm and 25mm outlets, thanks to the hose connector.

| Articolo - Item | €/pc. |
|-----------------|-------|
| Z 08 20 090 | |

made by

| Mod. |
|------|
| 90° |

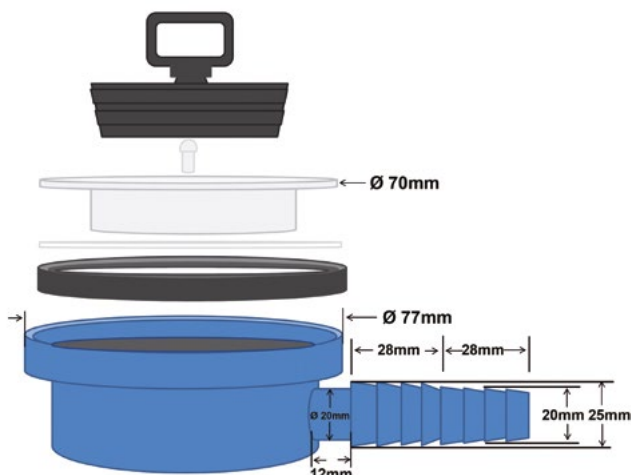

Serbatoi rigidi colore bianco per riserva acqua

Con tappo di ispezione e fori ciechi già filettati per raccordi.
In materiale atossico. 6 predisposizioni per raccordi: 2 ø38, 3 ø15, 1 ø19 mm.

Rigid water tanks

Manufactured in non-toxic material. Complete with inspection plug.
Ready to fit 6 joints: 2 ø38, 3 ø15, 1 ø19 mm.

| Articolo - Item | €/pc. | Lt. | AxB | H cm. |
|------------------------|-------|-----|--------|-------|
| N 01 20 077 | | 77 | 80x48 | 20 |
| N 01 20 084 | | 84 | 88x48 | 20 |
| N 01 20 092 | | 92 | 80x58 | 20 |
| N 01 20 108 | | 108 | 80x68 | 20 |
| N 01 22 077 | | 64 | 77x38 | 22 |
| N 01 22 088 | | 73 | 88x38 | 22 |
| N 01 22 110 | | 93 | 112x38 | 22 |
| N 01 22 123 | | 103 | 123x38 | 22 |
| N 01 22 133 | | 110 | 133x38 | 22 |
| N 01 05 026 | | 48 | 48x40 | 26 |
| N 01 10 026 | | 105 | 88x48 | 26 |
| N 01 08 030 | | 80 | 65x45 | 25 |
| N 01 28 094 | | 94 | 75x45 | 28 |
| N 01 28 105 | | 105 | 90x45 | 28 |
| N 01 28 120 | | 120 | 95x45 | 28 |
| N 01 28 132 | | 132 | 105x45 | 28 |
| N 01 28 150 | | 150 | 120x45 | 28 |
| N 01 35 148 | | 148 | 85x48 | 35 |
| N 01 20 112 NEW | | 112 | 80x70 | 20 |
| N 01 20 095 NEW | | 95 | 80x60 | 20 |
| N 01 22 092 NEW | | 92 | 110x38 | 22 |
| N 01 22 083 NEW | | 83 | 100x38 | 22 |
| N 01 28 112 NEW | | 112 | 90x45 | 28 |
| N 01 28 125 NEW | | 125 | 100x45 | 28 |
| N 01 30 126 NEW | | 126 | 88x48 | 30 |



COMPLETE WITH

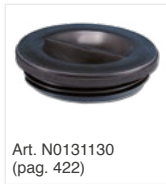

SUGGESTED ITEM

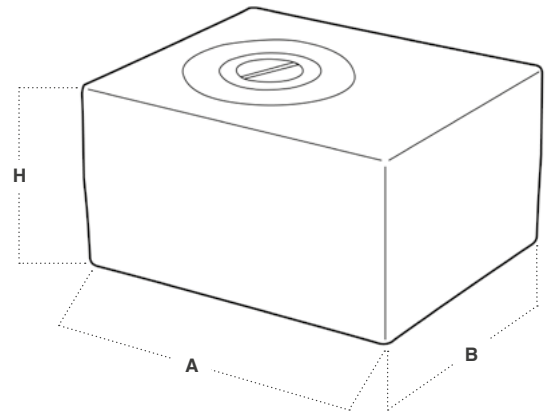

Tappo per serbatoi rigidi

Fabbricato in plastica.

Plug for water tank

Manufactured in plastic.

| Articolo - Item | €/pc. | Mod. | Ø mm. |
|-----------------|-------|-------------------------|-------|
| N 01 31 130 | | Tappo maschio-Male plug | 130 |



Raccordi per serbatoi rigidi

Fabbricati in nylon.

Connections for water tanks

Manufactured in nylon.

| Articolo - Item | €/pc. | Portagomma Hose adaptor mm. | Filetto Thread " | Tipo Type |
|-----------------|-------|--------------------------------|---------------------|-----------------|
| N 01 35 014 | | 35 | 1"1/4 | Carico-Inlet |
| N 01 12 012 | | 12 | 1/2" | Scarico-Outlet |
| N 01 12 038 | | 12 | 3/8" | Sfiato-Air hole |
| N 01 35 038 | | 35 | 1"1/4 | Carico-Inlet |
| N 01 12 090 | | 12 | 1/2" | Sfiato-Air hole |

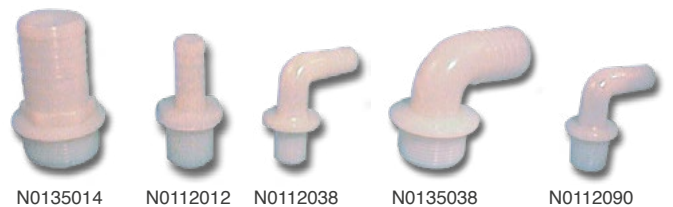

Kit serbatoio + Autoclave

Serbatoio in polietilene alimentare già assemblato con autoclave P1612030. Consigliato per una terza utenza. Completo di tubo acqua 20 cm.

Tank + fresh water pump kit

Polyethylene tank with fresh water pump P1612030. Recommended for 1/3 taps. Complete with water pipe 20 cm.

| Articolo - Item | €/Kit. | A cm. | B cm. | H cm. | Lt. | Raccordo entrata | Sfiato |
|-----------------|--------|-------|-------|-------|-----|------------------|--------|
| N 01 74 048 | | 47 | 39 | 26,50 | 48 | 1" 1/2 | 3/4" |

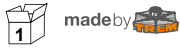

COMPLETO DI-COMPLETE WITH



Art. P1612030 (pag. 424)

Art. N0112038 (pag. 422)

Art. N0112012 (pag. 422)

Art. N1812118 (pag. 453)

SUGGESTED ITEM



RACCORDI (pag. 422)

SENSORI DI LIVELLO (pag. 286)

Art. D1000042 (pag. 116)

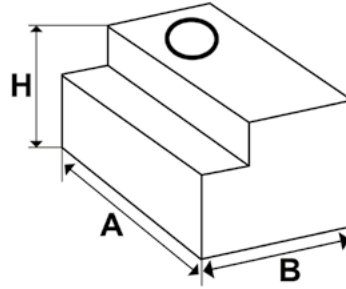
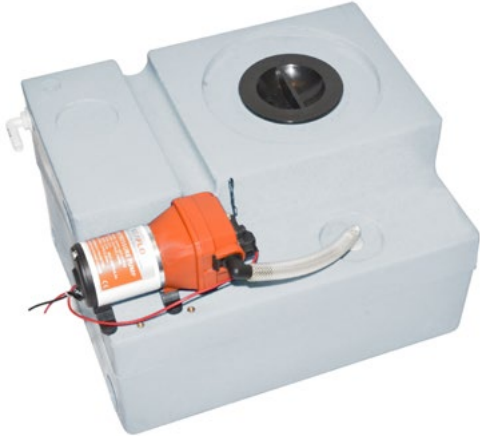

Serbatoi rettangolari per acqua potabile

Fabbricati in PVC elettrosaldato atossico. Completati di bocchettoni per entrata e uscita acqua. Provvisti di 1 portagomma ø 16 e 2 da ø 37 mm.

Fresh water tanks

Manufactured in non-toxic electrowelded PVC. Complete with water inlet & outlet joints. With 1 hose adapter ø 16 & 2 hose adapters ø 37 mm.

| Articolo - Item | €/pc. | Lt. | mm. |
|-----------------|-------|-----|-------|
| N 01 05 074 | | 55 | 74x60 |
| N 01 07 074 | | 75 | 74x76 |
| N 01 10 074 | | 100 | 74x90 |



Serbatoi acqua

Completati di tappo e pescanti.

Water tanks

Supplied with cap and float.

| Articolo - Item | €/pc. | Lt. | cm. | H cm. |
|-----------------|-------|-----|-------|-------|
| N 02 22 030 | | 35 | 50x35 | 22 |
| N 02 30 060 | | 60 | 65x35 | 30 |



SUGGESTED ITEM

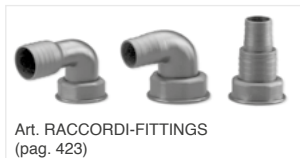

Art. RACCORDI-FITTINGS (pag. 423)



Raccordi imbarco carburante Fittings for fuel tank

| Articolo - Item | €/pc. | Mod. | Per tubo- For pipe ø mm. |
|-----------------|-------|-----------------|--------------------------|
| N 01 50 000 | | Dritto-Straight | 35-50 |
| N 01 50 090 | | 90° | 50 |
| N 01 35 090 | | 90° | 35 |



N0150000



N0150090



N0135090

Autoclave a basso consumo

Può servire 2 utenze. Protezione termica contro i sovraccarichi. In grado di girare a secco senza rovinarsi.

Low-consumption fresh water pump

It can feed 2 taps at the same time. Wquipped with circuit breaker against overloads. It can run dry without any damage.

| Articolo - Item | €/pc. | Pressostato-Pressure switch Versione-Version | Pressostato-Pressure switch Calibrato a-Calibrated at | Portata-Flow Lt./min. | Consumo Current draw A | Portagomma Hose adaptor Ø mm. | Ricambi pressostato Pressure switch spares |
|-----------------|-------|---|--|--------------------------|---------------------------|----------------------------------|---|
| P 16 38 022 | | Automatic | 2,45 BAR | 3,8 | 2 | 10 | P1620040 |

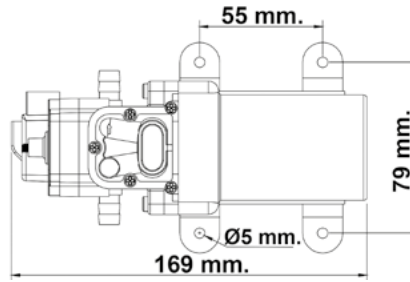

COMPLETO DI-COMLETE WITH



Art. P1620040 (pag. 424)

Autoclave autoaspirante a 4 valvole

Può girare a secco senza rovinarsi. Esente da vibrazioni, molto silenziosa. Bypass interno che salvaguardia la pompa da eccessiva pressione in entrata. Motore a magneti permanenti con albero autolubrificante. Il sistema a 4 valvole evita le caratteristiche pulsazioni delle altre autoclavi, a rubinetto semiaperto. Complete di 4 raccordi, 2 da 1/2" filettati + 2 da 14mm con portagomma da 1/2" e di filtro di aspirazione. I raccordi e il filtro si innestano a scatto.

4-diaphragm self-priming fresh water pump

It can run dry without damage, no vibrations, very quiet. Fitted with internal bypass for inlet pressure control. Permanent magnet motor with self-lubricating shaft. The 4-diaphragm system prevents the pulsations that usually occur in the other fresh water pumps with a semi-open tap. 4 plug-in fittings (2 x 1/2" threads and 2 x 14-mm with 1/2" hose adaptors) and a plug-in inlet strainer.

| Articolo - Item | €/pc. | Volts | Portata-Flow Lt./min. | Consumo Current draw A | Pressione esercizio Operating pressure Bar | Ricambi pressostato Pressure switch spares |
|-----------------|-------|-------|--------------------------|---------------------------|---|---|
| P 16 12 030 | | 12 | 12,5 | 4 | 2,00 | P1620035 |
| P 16 12 040 | | 12 | 17 | 15 | 2,80 | P1620040 |
| P 16 24 044 | | 24 | 17 | 6 | 2,80 | P1620040 |

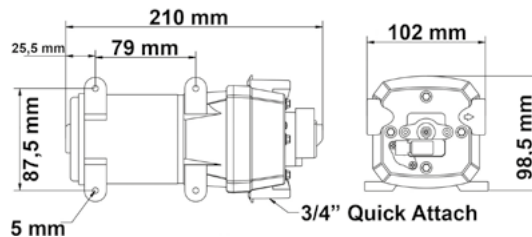

COMPLETO DI-COMLETE WITH



PRESSOSTATO-PRESSURE SWITCH (pag. 424)

Autoclave autoaspirante a 4 valvole

Può girare a secco senza rovinarsi. Esente da vibrazioni, molto silenziosa. Bypass interno che salvaguardia la pompa da eccessiva pressione in entrata. Motore a magneti permanenti con albero autolubrificante. 2 uscite filettate da 1/2"-14 MNPT.

4-diaphragm self-priming fresh water pump

It can run dry without damage, no vibrations, very quiet. Fitted with internal bypass for inlet pressure control. Permanent magnet motor with self-lubricating shaft. 2 x 1/2" threads.

| Articolo - Item | €/pc. | Volts | Portata-Flow Lt./min. | Consumo Current draw A | Pressione esercizio Operating pressure Bar | PSI |
|-----------------|-------|-------|--------------------------|---------------------------|---|-----|
| P 16 12 011 | | 12 | 11,5 | 7 | 3,80 | 55 |

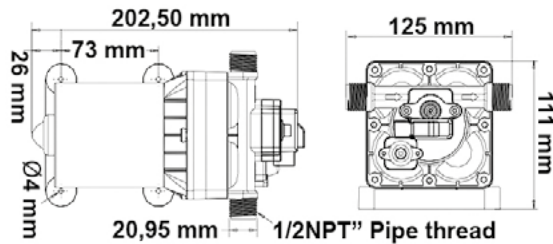

Pressostato per autoclavi

Pressure switch for water pumps

| Articolo - Item | €/pc. | PSI | Amp/H | kg. |
|-----------------|-------|-----|-------|-------|
| P 16 20 035 | | 17 | 20 | 0,100 |
| P 16 20 040 | | 40 | 20 | 0,100 |



Autoclave

Autoaspirante a basso consumo energetico, può servire contemporaneamente 2 rubinetti. Protezione interna contro i sovraccarichi, può girare a secco senza danni. Dotata di pressostato.

Self-priming fresh water pump

Low consumption self-priming pump. It can serve 2 taps at the same time and run dry without any damage. Inner protection system against incoming overpressure. Complete with pressure switch.

| Articolo - Item | €/pc. | Volts | Portata-Flow Lt./min. | Amp | PSI | Uscita-Out Ø mm. | kg. |
|-----------------|-------|-------|--------------------------|-----|-----|---------------------|-------|
| P 16 12 220 | | 12 | 3,8 | 1,8 | 40 | 9,5 | 0,600 |

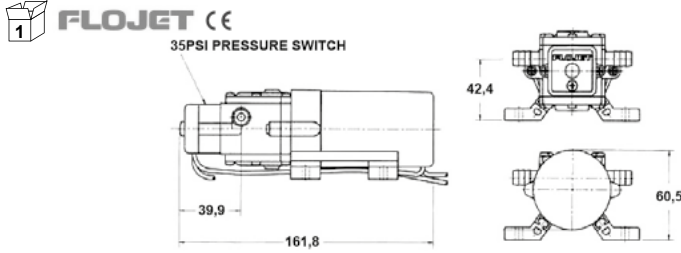

Autoclave TRIPLEX 3 valvole

Con bypass, garantisce un flusso uniforme e silenzioso eliminando i serbatoi di accumulo. Supporti in gomma morbida per minimizzare rumorosità e vibrazioni. Autoadescente fino a mt. 3, può funzionare a secco senza subire danni. Conforme ISO 8846 MARINE (ignition protection). Dotata di pressostato.

3-diaphragm self-priming fresh water pump

Quiet operation, pulsation-dampening bypass. Soft rubber supports to prevent vibrations. Self-priming up to 3 mt. It can run dry without damage. In compliance with ISO 8846 MARINE (ignition protection). Complete with pressure switch.

| Articolo - Item | €/pc. | Volts | Portata-Flow Lt./min. | Amp max | PSI | Uscita-Out Ø mm. | kg. |
|-----------------|-------|-------|--------------------------|---------|-----|---------------------|-------|
| P 16 20 916 | | 12 | 8 | 5,2 | 25 | 13 | 1,600 |
| P 16 44 050 | | 12 | 11 | 5,2 | 25 | 13 | 1,800 |

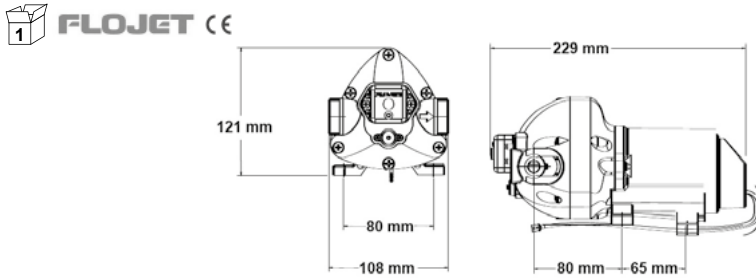

Pompa di sentina a girante

Prevalenza mt. 3. Corpo pompa in bronzo. Girante in neoprene.

Self-priming bilge pump

Head 3 mt. Bronze pump housing. Neoprene impeller.

| Articolo - Item | €/pc. | Volts | Portata-Flow Lt./min. | Amp | Autoad. mt. | Uscita-Out Ø | kg. |
|-----------------|-------|-------|--------------------------|-----|----------------|-----------------|-------|
| P 16 12 023 | | 12 | 30 | 8 | 2,5 | 1/2 gas | 2,600 |

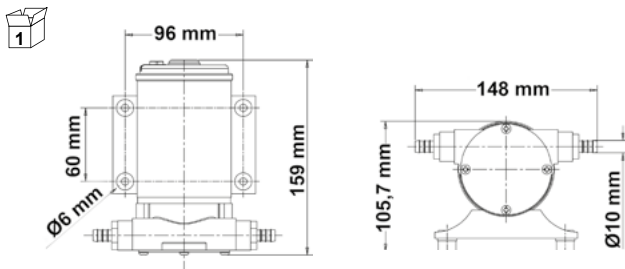

Pompa elettrica a girante

A girante autoadescente. Corpo in bronzo e viteria inox. Girante in neoprene.

Self-priming electrical pump

Bronze pump housing. Stainless steel screws. Neoprene impeller.

| Articolo - Item | €/pc. | Volts | Portata-Flow Lt./min. | Amp | Prev. mt. | Portagomma Hose adaptor |
|-----------------|-------|-------|--------------------------|-----|--------------|---------------------------------------|
| P 16 12 035 | | 12 | 25 | 8 | 4 | 169x120x97H 1/2 Male 3/4 Female |



Elettropompa a membrana autoadescente

Indicata per acqua. Costruita in materiale resistente all'usura ed agli urti. Entrata uscita 3/4". Certificata CE secondo la norma EN 28846 - ISO 8846 Marine.

Membrane self-priming electrical pump

Inlet-Outlet 3/4". Suitable for water. CE marked according to Rule EN 28846 - ISO 8846 Marine.

| Articolo - Item | €/pc. | Volts | Portata-Flow Lt./min. | Portata-Flow Lt./H | Amp/H |
|-----------------|-------|-------|--------------------------|-----------------------|-------|
| P 02 12 120 | | 12 | 18 | 1200 | 7 |



Pompa di sentina automatica 500GPH **Automatic bilge pump 500GPH**

12V. Altezza geodetica 4 mt. 12V. Geodetic height 4 mt.

| Articolo - Item | €/pc. | Amp. | Uscita-Outlet | |
|-----------------|-------|------|---------------|-------|
| | | | Lt./H | Ø mm. |
| P 16 12 105 | | 3 | | 19 |



Pompa di sentina automatica 750GPH **Automatic bilge pump 750GPH**

12V. Altezza geodetica 4 mt. 12V. Geodetic height 4 mt.

| Articolo - Item | €/pc. | Amp. | Uscita-Outlet | |
|-----------------|-------|------|---------------|-------|
| | | | Lt./H | Ø mm. |
| P 16 12 106 | | 5 | | 19 |

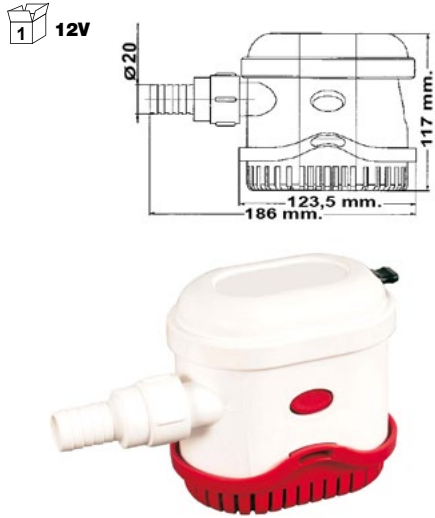

Pompa di sentina automatica 1100GPH **Automatic bilge pump 1100GPH**

12V. Altezza geodetica 4 mt. 12V. Geodetic height 4 mt.

| Articolo - Item | €/pc. | Amp. | Uscita-Outlet | |
|-----------------|-------|------|---------------|-------|
| | | | Lt./H | Ø mm. |
| P 16 12 107 | | 5 | | 29 |

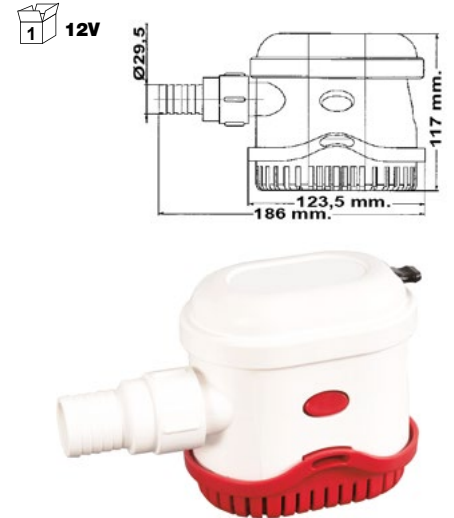

Pompa di sentina automatica 1500GPH **Automatic bilge pump 1500GPH**

12V. Altezza geodetica 4 mt. 12V. Geodetic height 4 mt.

| Articolo - Item | €/pc. | Amp. | Lt./H | Uscita-Outlet |
|-----------------|-------|------|-------|---------------|
| | | | | Ø mm. |
| P 16 12 150 | | 9 | 5000 | 29 |

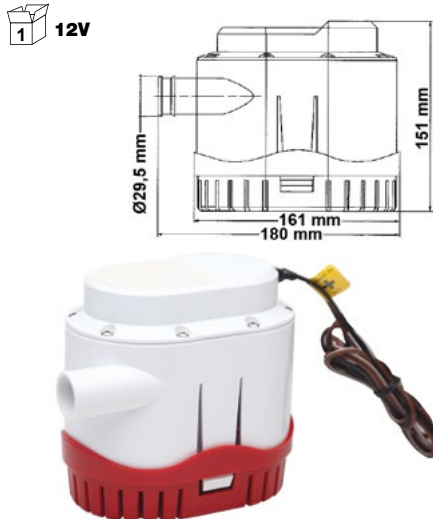

Pompa di sentina automatica 2000GPH **Automatic bilge pump 2000GPH**

12V. Altezza geodetica 4 mt. 12V. Geodetic height 4 mt.

| Articolo - Item | €/pc. | Amp. | Lt./H | Uscita-Outlet |
|-----------------|-------|------|-------|---------------|
| | | | | Ø mm. |
| P 16 12 200 | | 15 | 7000 | 29 |



Pompa di sentina automatica 1500GPH **Automatic bilge pump 1500GPH**

12V. Altezza geodetica 4 mt. 12V. Geodetic height 4 mt.

| Articolo - Item | €/pc. | Amp. | Lt./H | Uscita-Outlet |
|-----------------|-------|------|-------|---------------|
| | | | | Ø mm. |
| P 16 12 207 | | 8 | 5550 | 29 |

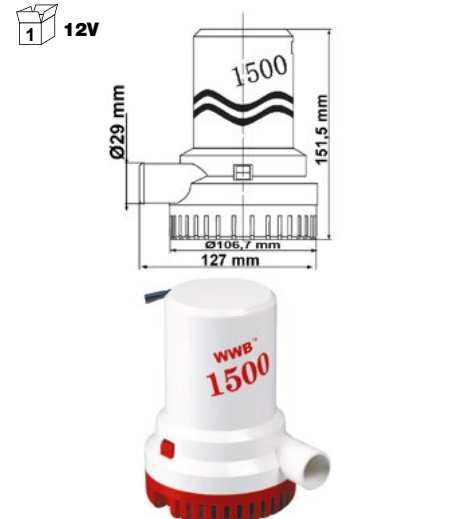

Pompa di sentina automatica 2000GPH **Automatic bilge pump 2000GPH**

Altezza geodetica 8 mt. Geodetic height 8 mt.

| Articolo - Item | €/pc. | Volts | Amp. | Lt./H | Uscita-Outlet |
|-----------------|-------|-------|------|-------|---------------|
| | | | | | Ø mm. |
| P 16 12 208 | 12 | 8 | 7500 | 29 | |
| P 16 24 208 | 24 | 6 | 7500 | 29 | |

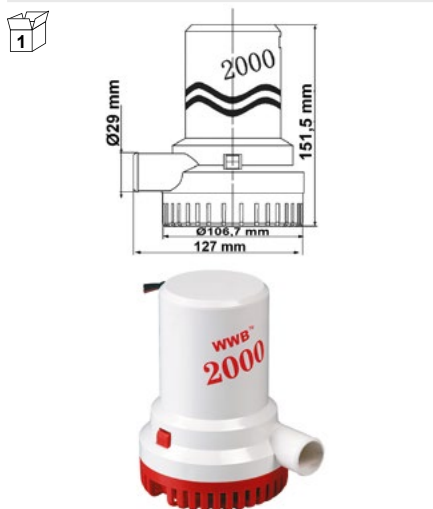

Pompa di sentina automatica 3700GPH **Automatic bilge pump 3700GPH**

Altezza geodetica 8 mt. Geodetic height 8 mt.

| Articolo - Item | €/pc. | Volts | Amp. | Lt./H | Uscita-Outlet |
|-----------------|-------|-------|-------|-------|---------------|
| | | | | | Ø mm. |
| P 16 12 309 | 12 | 11 | 14000 | 40 | |



Pompa di sentina automatica 4700GPH **Automatic bilge pump 4700GPH**

Altezza geodetica 8 mt. Geodetic height 8 mt.

| Articolo - Item | €/pc. | Volts | Amp. | Lt./H | Uscita-Outlet |
|-----------------|-------|-------|-------|-------|---------------|
| | | | | | Ø mm. |
| P 16 12 918 | 12 | 16 | 18000 | 40 | |

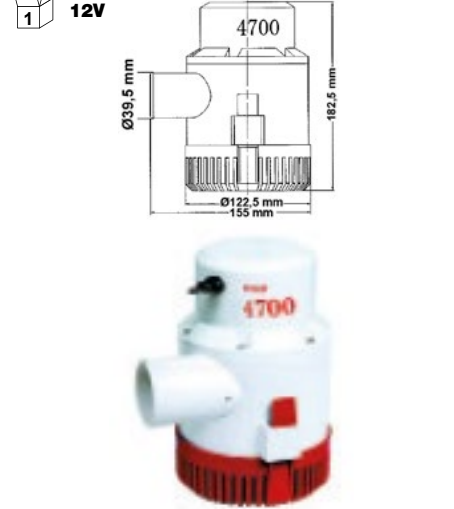

Pompa ad immersione **Submersible pump**
STORM 300 **STORM 300**

Dimensioni: Ø66x97,5H. Size: Ø66x97,5H.
Portata 1200 Lt./H. Flow rate 1200 Lt./H.
Gira a secco. CE DIR 89/336. Dry run. CE DIR 89/336.
RINA EN28846/28849. RINA EN28846/28849.

| Articolo - Item | €/pc. | Volts | Amp. | Prev. mt. | Uscita-Outlet Ø mm. |
|-----------------|-------|-------|------|-----------|---------------------|
| P 02 00 098 | 12 | 1,4 | 1,5 | 19 | |



Pompa ad immersione **Submersible pump**
STORM 400 **STORM 400**

Dimensioni: Ø82x135H. Size: Ø82x135H.
Portata 1500 Lt./H. Flow rate 1500 Lt./H.
Gira a secco. CE DIR 89/336. Dry run. CE DIR 89/336.
RINA EN28846/28849. RINA EN28846/28849.

| Articolo - Item | €/pc. | Volts | Amp. | Prev. mt. | Uscita-Outlet Ø mm. |
|-----------------|-------|-------|------|-----------|---------------------|
| P 02 00 080 | 12 | 5,5 | 4,5 | 19 | |



Pompa ad immersione **Submersible pump**
STORM 600 **STORM 600**

Dimensioni: Ø88x135H. Size: Ø88x135H.
Portata 2500 Lt./H. Flow rate 2500 Lt./H.
Gira a secco. CE DIR 89/336. Dry run. CE DIR 89/336.
RINA leg. 94/25 EN28846/28849. RINA leg. 94/25 EN28846/28849.

| Articolo - Item | €/pc. | Volts | Amp. | Prev. mt. | Uscita-Outlet Ø mm. |
|-----------------|-------|-------|------|-----------|---------------------|
| P 02 00 120 | 12 | 5,5 | 4,5 | 19 | |



Pompa ad immersione **Submersible pump**
STORM 1400 **STORM 1400**

Dimensioni: Ø121x165H. Size: Ø121x165H.
Portata 5700 Lt./H. Flow rate 5700 Lt./H.
Gira a secco. CE DIR 89/336. Dry run. CE DIR 89/336.
RINA leg. 94/25 EN28846/28849. RINA leg. 94/25 EN28846/28849.

| Articolo - Item | €/pc. | Volts | Amp. | Prev. mt. | Uscita-Outlet Ø mm. |
|-----------------|-------|-------|------|-----------|---------------------|
| P 02 00 170 | 12 | 7 | 3 | 29 | |
| P 02 24 170 | 24 | 13 | 3 | 29 | |



Pompa ad immersione **Submersible pump**
STORM 2300 **STORM 2300**

Dimensioni: Ø132x195H. Size: Ø132x195H.
Portata 9000 Lt./H. Flow rate 9000 Lt./H.
Gira a secco. CE DIR 89/336. Dry run. CE DIR 89/336.
RINA leg. 94/25 EN28846/28849. RINA leg. 94/25 EN28846/28849.

| Articolo - Item | €/pc. | Volts | Amp. | Prev. mt. | Uscita-Outlet Ø mm. |
|-----------------|-------|-------|------|-----------|---------------------|
| P 02 00 235 | 12 | 10 | 4 | 32 | |
| P 02 24 235 | 24 | 5 | 4 | 32 | |



Pompa ad immersione **Submersible pump**
500GPH **500GPH**

Dimensioni: Ø74x81Lx95H. Size: Ø74x81Lx95H.
Portata 1900 Lt./H. Flow rate 1900 Lt./H.
Tubo Ø 20 mm. Hose Ø 20 mm.

| Articolo - Item | €/pc. | Volts | Amp. | Prev. mt. |
|-----------------|-------|-------|------|-----------|
| P 02 36 701 | 12 | | 2,5 | 3 |



Pompa ad immersione **Automatic**
automatica **submersible pump**

Portata 2200 lt./h. a livello Fabbricata in Abs antiurto. Provvista di basetta a scatto per l'eventuale ispezione o pulizia. La pompa si collega con interruttore a 3 poli. Entra in funzionamento ogni 15 minuti. Se non trova acqua gira 2 secondi e si ferma, se trova acqua gira sino allo svuotamento della sentina.

| Articolo - Item | €/pc. | Volts | Amp. | H mm. | Uscita-Outlet Ø mm. |
|-----------------|-------|-------|-------|-------|---------------------|
| P 02 12 126 | 12 | 4 | 126,5 | 19 | |



Pompa ad immersione **Submersible**
«Tipo Attwood» **pump «Attwood»**
450GPH **450GPH**

Basetta a scatto per facilitare la pulizia. With latch base for easy control and cleaning. Altezza geodetica 2,00 mt. Geodetic height 2,00 mt.

| Articolo - Item | €/pc. | Volts | Amp. | Uscita-Outlet Ø mm. |
|-----------------|-------|-------|------|---------------------|
| P 02 10 101 | 12 | 1,5 | 19 | |



Pompa ad immersione **Submersible**
«Tipo Attwood» **pump «Attwood»**
900GPH **900GPH**

Basetta a scatto per facilitare la pulizia. With latch base for easy control and cleaning. Altezza geodetica 3,50 mt. Geodetic height 3,50 mt.

| Articolo - Item | €/pc. | Volts | Amp. | Uscita-Outlet Ø mm. |
|-----------------|-------|-------|------|---------------------|
| P 02 10 301 | 12 | 3,5 | 29 | |



Pompa ad immersione

Fabbricata in Abs antiurto. H 93 mm.
Consumo di energia 2 A/ora.
Provvista di basetta a scatto per l'eventuale ispezione o pulizia.
Altezza geodetica 3,50 mt.

Bilge pump

Made of shockproof Abs.
Low amperage draw: 2 A/h.
With latch base for easy control and cleaning.
Geodetic height 3,50 mt.

| Articolo - Item | €/pc. | Volts | Portata Flow rate GPH | Lt./H | Bocca Opening Ø mm. | kg. |
|-----------------|-------|-------|--------------------------|-------|------------------------|-------|
| P 16 00 035 | | 12 | 360 | 1360 | 19 | 0,320 |

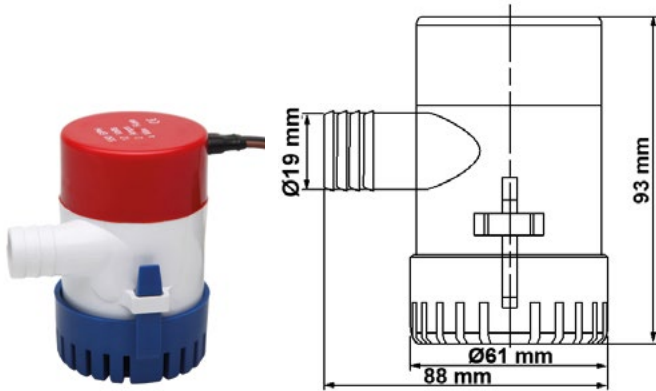

Pompa ad immersione

Fabbricata in Abs antiurto. H 93 mm.
Consumo di energia 2,5 A/ora.
Provvista di basetta a scatto per l'eventuale ispezione o pulizia.
Altezza geodetica 3,80 mt.

Bilge pump

Made of shockproof Abs.
Low amperage draw: 2,5 A/h.
With latch base for easy control and cleaning.
Geodetic height 3,80 mt.

| Articolo - Item | €/pc. | Volts | Portata Flow rate GPH | Lt./H | Bocca Opening Ø mm. | kg. |
|-----------------|-------|-------|--------------------------|-------|------------------------|-------|
| P 16 00 055 | | 12 | 550 | 2080 | 19 | 0,320 |

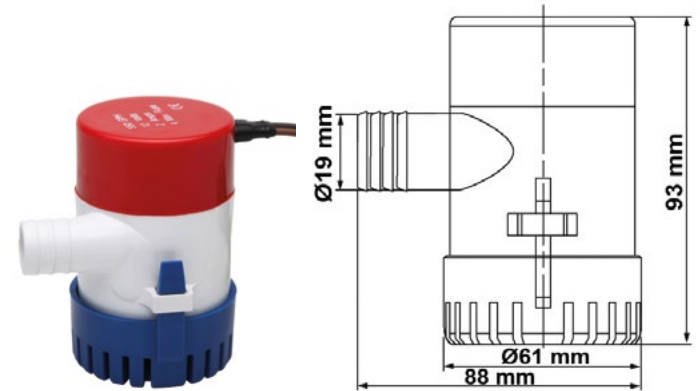

Pompa ad immersione

Fabbricata in Abs antiurto. H 107 mm.
Consumo di energia 2 A/ora.
Provvista di basetta a scatto per l'eventuale ispezione o pulizia.
Altezza geodetica 4,00 mt.

Bilge pump

Made of shockproof Abs.
Low amperage draw: 2 A/h.
With latch base for easy control and cleaning.
Geodetic height 4,00 mt.

| Articolo - Item | €/pc. | Volts | Portata Flow rate GPH | Lt./H | Bocca Opening Ø mm. | kg. |
|-----------------|-------|-------|--------------------------|-------|------------------------|-------|
| P 16 00 750 | | 12 | 750 | 2835 | 29 | 0,320 |

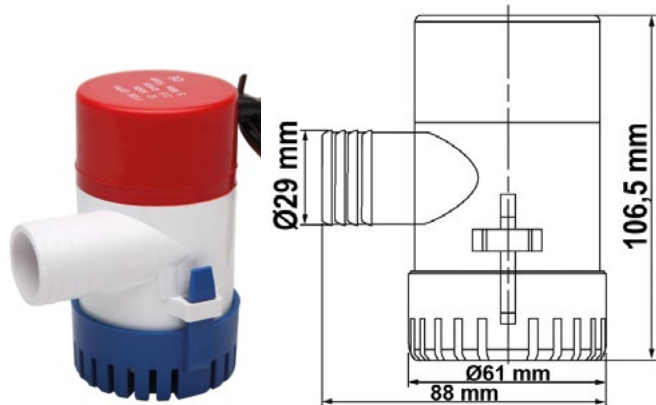

Pompa ad immersione

Fabbricata in Abs antiurto. H 107 mm.
Consumo di energia 2 A/ora 12V. 1,5 A/ora 24V.
Provvista di basetta a scatto per l'eventuale ispezione o pulizia.
Altezza geodetica 4,00 mt.

Bilge pump

Made of shockproof Abs.
Low amperage draw: 2 A/h. 12V. 1,5A/h. 24V.
With latch base for easy control and cleaning.
Geodetic height 4,00 mt.

| Articolo - Item | €/pc. | Volts | Portata Flow rate GPH | Lt./H | Bocca Opening Ø mm. | kg. |
|-----------------|-------|-------|--------------------------|-------|------------------------|-------|
| P 16 00 110 | | 12 | 1100 | 4160 | 29 | 0,440 |

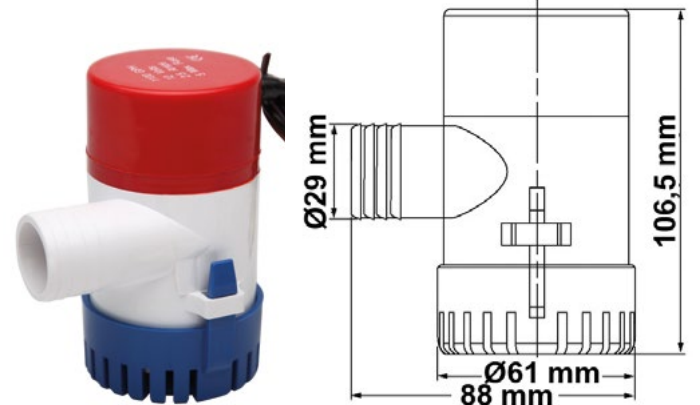

Pompa di sentina automatica basso profilo

Disegnata per installazione in spazi ridotti o di difficile accesso (zona sotto i motori o sotto al pavimento del deck). Funzione automatica con sensore IC. Connessione ruotabile e coperchio rimovibile per facile pulizia. Montaggio verticale o orizzontale. Prevalenza: 2,5 mt. ø uscite 19mm. e 25mm.

Automatic low profile bilge pump

Designed for small or tight space (under engines or cockpit floors). Automatic operation with IC sensor design. Outlet port can be rotated & cover can be removed for easy cleaning. Vertical or horizontal mounting. Delivery head 2,5m. Hose ø 19mm and 25mm.

| Articolo - Item | €/pc. | Volts | Amp. | mm. | Portata-Flow rate (GpH - Lt/h) | kg. |
|-----------------|-------|-------|------|----------------|-----------------------------------|-------|
| P 02 12 189 | | 12 | 2,5 | 223,2x122,6x60 | 500-1890 | 0,750 |

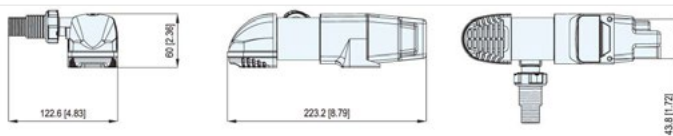

Elettropompe di sentina «Sahara» con interruttore automatico incorporato

Elettropompe di sentina ad immersione «Attwood» con interruttore automatico a galleggiante incorporato per azionamento in automatico o manuale. Funzionamento 12V.

Bilge pump «Sahara» with built-in floating automatic switch

Equipped with built-in floating automatic switch.
Power supply 12V.

| Articolo - Item | €/pc. | Mod. | A/h | Prev. max mt. | Portata Flow rate 1 mt. lt./h | Bocca Opening Ø mm. | mm. |
|-----------------|-------|------|-----|------------------|-------------------------------------|---------------------------|-------------|
| P 16 05 050 | | 500 | 1,5 | 2,80 | 350 | 19 | 140x90x100H |
| P 16 11 110 | | 1100 | 4 | 3,70 | 980 | 29 | 140x90x100H |



Pompe ad immersione

Equipaggiate con un sensore elettronico REED incorporato che garantisce un funzionamento completamente automatico. La base a sgancio rapido ne facilita la pulizia. Funzionamento automatico o manuale con 3 cavi di collegamento.

Bilge pumps

Equipped with a built-in REED electronic sensor that enables a fully automatic running of the pump. Quick release base for easy cleaning operation. Manual or automatic running by 3 connection cables.

| Articolo - Item | €/pc. | Volts | Amp | Portata-Flow Lt./h | Prev. mt. | ↑ ↓ mm. | Tubo-Hose Ø mm. |
|-----------------|-------|-------|-----|--------------------|-----------|--------------|-----------------|
| P 02 12 605 | | 12 | 1,6 | 1890 | 2,5 | 136x82x110H | 20 |
| P 02 12 610 | | 12 | 4,5 | 3786 | 4 | 165x96x130H | 30 |
| P 02 12 615 | | 12 | 9 | 5676 | 4 | 191x108x150H | 30 |

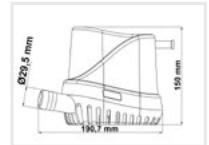
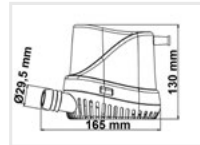
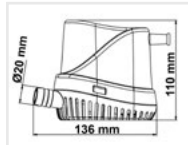

Pompe ad immersione automatica

Modello compatto, con sensore di livello elettronico integrato. Corpo in ABS. Albero in acciaio inox. Consumi elettrici ridotti. Rimozione a scatto della pompa dalla base.

Automatic bilge pumps

Very compact, with integrated electronic level sensor. ABS body. Stainless steel shaft. Reduced electricity consumption. Removable from base with snap coupling.

| Articolo - Item | €/pc. | Mod. | Volts | Amp | Portata-Flow GpH | Testa-Head mt. | Wire lead mt. | Bocca - Outlet Ø mm. | kg. |
|-----------------|-------|----------------|-------|-----|------------------|----------------|---------------|----------------------|-------|
| P 02 12 606 | | SFBP1-G600-06 | 12 | 2,5 | 600 | 2,5 | 1 | 19 | 0,520 |
| P 02 12 756 | | SFBP1-G750-06 | 12 | 3,0 | 750 | 3,0 | 1 | 19 | 0,520 |
| P 02 24 756 | | SFBP2-G750-06 | 24 | 1,6 | 750 | 3,0 | 1 | 19 | 0,520 |
| P 02 12 110 | | SFBP1-G1100-06 | 12 | 3,0 | 1100 | 4,0 | 1 | 29 | 0,600 |

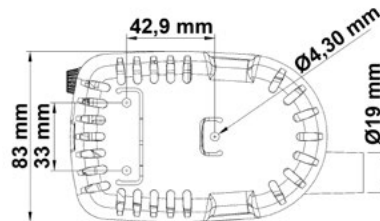
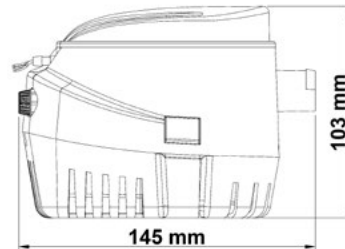

VASCA DI SCARICO DOCCETTE | DRAINING TANK FOR SHOWERS

Vasca di scarico per doccette completa di pompa

Uscita Ø 19 mm.

Draining tank for showers complete with pump

Outlet Ø 3/4"

| Articolo - Item | €/pc. | Volts | Amp | Portata-Flow GpH | Portata-Flow Lt./min. | Altezza geodetica Geodetic height mt. | Cavo-Cable mt. | Entrata-Inlet Ø mm. | kg. |
|-----------------|-------|-------|-----|------------------|-----------------------|---------------------------------------|----------------|---------------------|-------|
| N 01 12 600 | | 12 | 2,5 | 600 | 40 | 2,5 | 1 | 19/25/29/38 | 1,170 |
| N 01 24 600 | | 24 | 1,5 | 600 | 40 | 2,5 | 1 | 19/25/29/38 | 1,170 |
| N 01 11 701 | | 12 | 3 | 750 | 48 | 3 | 1 | 19/25/29/38 | 1,170 |
| N 01 24 750 | | 24 | 1,6 | 750 | 48 | 3 | 1 | 19/25/29/38 | 1,170 |

COMPLETO DI-COMPLETE WITH



Art. pompa (pag. 429)

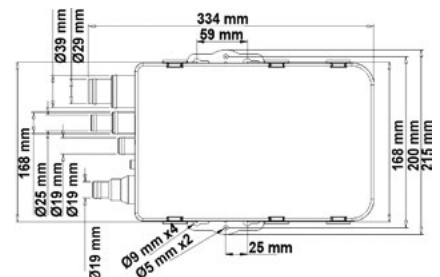
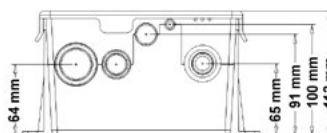

Pompa per lavello e doccia

Pump for sink and shower

Non autoadescante.

Not self-priming.

| Articolo - Item | €/pc. | Volts | Amp. | Lt./H | Prev. mt. | Uscita-Outlet Ø mm. | ↳ mm. |
|-----------------|-------|-------|------|-------|-----------|---------------------|---------|
| P 16 06 302 | | 12 | 1,5 | 400 | 2 | 10 | 115xØ45 |



Pompa in linea

In-line pump

Non autoadescante.

Not self-priming.

| Articolo - Item | €/pc. | Volts | Amp. | Lt./H | Prev. mt. | Inlet-Outlet Ø mm. | ↳ mm. |
|-----------------|-------|-------|------|-------|-----------|--------------------|---------|
| P 16 12 303 | | 12 | 3 | 1060 | 7 | 14 | 138xØ43 |



Pompa ad immersione

Submersible bilge pump

Di ridotte dimensioni, può facilmente entrare in canestri e serbatoi.

Small in size, it can easily fit into jerrycans and tanks.

| Articolo - Item | €/pc. | Volts | Amp. | Lt./H | Prev. mt. | Uscita-Outlet Ø mm. | ↳ mm. |
|-----------------|-------|-------|------|-------|-----------|---------------------|-----------|
| P 02 08 035 | | 12 | 2,0 | 380 | 4 | 10 | 103,5xØ40 |



ACCORDING TO CE RULE 89/336 ELECTROMAGNETIC COMPATIBILITY



Pompa ad immersione

Submersible bilge pump

Di ridotte dimensioni, può facilmente entrare in canestri e serbatoi.

Small in size, it can easily fit into jerrycans and tanks.

| Articolo - Item | €/pc. | Volts | Amp. | Lt./H | Prev. mt. | Uscita-Outlet Ø mm. | ↳ mm. |
|-----------------|-------|-------|------|-------|-----------|---------------------|---------|
| P 02 12 052 | | 12 | 2,5 | 510 | 4 | 10 | 105xØ40 |



ACCORDING TO CE RULE 89/336 ELECTROMAGNETIC COMPATIBILITY



Pompa ad immersione

Submersible bilge pump

| Articolo - Item | €/pc. | Volts | Lt./min. | ↳ mm. | Ⓢ kg. |
|-----------------|-------|-------|----------|---------|-------|
| P 02 12 015 | | 12 | 15 | 150xØ40 | 0,170 |



Pompa ad immersione

Submersible bilge pump

| Articolo - Item | €/pc. | Volts | Lt./min. | ↳ mm. | Ⓢ kg. |
|-----------------|-------|-------|----------|---------|-------|
| P 02 12 010 | | 12 | 10 | 140xØ35 | 0,140 |



Pompa ad immersione acqua e diesel

Submersible bilge pump water and gasoline

Facile da installare e trasportare. La pompa può pompare fino a 80°C di acqua di mare e 40°C di diesel. Motore di lunga durata e silenzioso. Cavo di 1 metro incluso.

Easy to install and carry. The pump is able to pump 80°C seawater and 40°C diesel. With long life and quiet perform engine. Supplied with cable 1 mt.

| Articolo - Item | €/pc. | Volts | Amp. | Portata Flow rate GPH | Bocca Opening Ø mm. | ↳ mm. |
|-----------------|-------|-------|------|-----------------------|---------------------|---------|
| P 02 12 028 | | 12 | 4,5 | 280 | 1/2" | 176xØ42 |

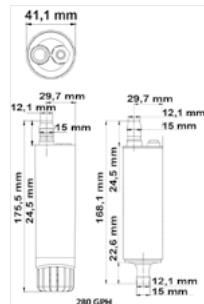

Pompa di sentina

Bilge pump

Fabbricata in ABS.

Manufactured in ABS.

| Articolo - Item | €/pc. | Volts | H mm. | Uscita-Outlet Ø mm. | Ⓢ kg. |
|-----------------|-------|-------|-------|---------------------|-------|
| P 02 12 031 | | 12 | 100 | 20 | 0,210 |



Pompa di sentina manuale

Hand bilge pump

Corpo in nylon.

Nylon body.

| Articolo - Item | €/pc. | Lt./min. | cl./Pompata cl./Inflate | kg. |
|-----------------|-------|----------|----------------------------|-------|
| P 02 18 515 | | 50 | 30 | 0,740 |



Pompa di sentina a diaframma manuale

Diaphragm hand pump

Corpo in polipropilene.
Dimensioni: 180x120x75 mm.

Body in glass-filled polypropylene.
Size: 180x120x75 mm.

| Articolo - Item | €/pc. | Mod. | Lt./min. | Portagomma Hose adaptor Ø mm. | kg. |
|-----------------|-------|----------------------------------|----------|----------------------------------|-------|
| P 02 45 720 | | Maniglia alluminio Alu handle | 45 | 35 | 0,570 |

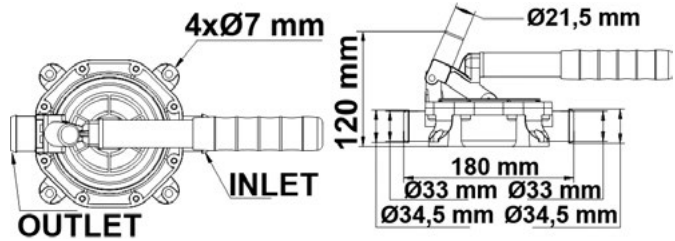

Pompa di sentina a diaframma manuale

Diaphragm hand pump

Corpo in polipropilene.
Dimensioni: 180x120x75 mm.

Body in glass-filled polypropylene.
Size: 180x120x75 mm.

| Articolo - Item | €/pc. | Mod. | Lt./min. | Portagomma Hose adaptor Ø mm. | kg. |
|-----------------|-------|-------------------------------------|----------|----------------------------------|-------|
| P 02 18 510 | | Maniglia plastica Plastic handle | 45 | 35 | 0,570 |

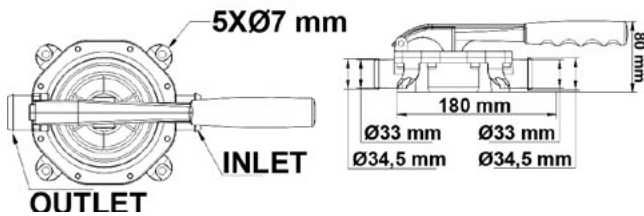

Pompetta per svuotamento automatico

Pump for automatic emptying

Eroga fino a 2500 litri al giorno e ha una resistenza di 10.000 N.
Ideale per svuotare l'imbarcazione che si riempie d'acqua rimanendo ormeggiata in porto.

Can supply up to 2500 lt./day:
Resistance 10.000 N.
Suitable for water emptying when the boat is mooring.

| Articolo - Item | €/pc. | Mod. | kg. |
|-----------------|-------|----------------------------------|-------|
| P 01 00 008 | | Pompetta-Pump | 0,320 |
| P 01 00 009 | | Tubo estensibile-Extensible pipe | 0,190 |



Pompa di sentina a mano completa di adattatore

Hand suction pump with adapter

Provvista di adattatore, tubo di riduzione 80 cm. e di tubo flessibile. Ø 50 mm.

Supplied with an adapter for flooring and with 80 cm. of plastic hose. Ø 50 mm.

| Articolo - Item | €/pc. | lt./Pompata lt./Inflate | Lunghezza Length cm. | pcs. |
|-----------------|-------|----------------------------|-------------------------|------|
| P 02 50 035 | | 0,30 | 35 | 60 |
| P 02 50 055 | | 0,50 | 55 | 50 |
| P 02 50 075 | | 0,80 | 75 | 15 |
| P 02 50 100 | | 1,00 | 100 | 20 |
| P 02 00 070 | | Adattatore-Adapter | | 6 |



Interruttore galleggiante per pompe elettriche

Fabbricato in ABS.

Floating switch for electric pumps

Manufactured in ABS.

| Articolo - Item | €/pc. | Volts | Per pompa-For pump max Amp. | kg. |
|-----------------|-------|-------|-----------------------------|-------|
| P 02 12 000 | | 12-24 | 10 | 0,200 |



Interruttore galleggiante per pompe elettriche

Fabbricato in ABS.

Floating switch for electric pumps

Manufactured in ABS.

| Articolo - Item | €/pc. | Volts | Per pompa-For pump max Amp. | kg. |
|-----------------|-------|-------|-----------------------------|-------|
| P 02 10 292 | | 12 | 15 | 0,150 |



Interruttore per pompe elettriche

Fabbricato in ABS.
ISO 8846 Marine.

Floating switch for electric pumps

Manufactured in ABS.
ISO 8846 Marine.

| Articolo - Item | €/pc. | Volts | Per pompa-For pump max Amp. | kg. |
|-----------------|-------|-------|-----------------------------|-----|
| P 02 15 106 | | 12 | 15 | |



Interruttore a sensore

Fabbricato in ABS.

Sensor switch

Manufactured in ABS.

| Articolo - Item | €/pc. | Volts | Per pompa-For pump max Amp. | kg. |
|-----------------|-------|-------|-----------------------------|-------|
| P 02 15 012 | | 12 | 15 | 0,110 |



Interruttore galleggiante

Funzionamento senza l'ausilio del mercurio.
Larghezza base 83 mm.
Lunghezza galleggiante 113 mm.

Floating switch

Works without mercury.
Base width 83 mm.
Floating length 113 mm.

| Articolo - Item | €/pc. | Volts | Per pompa-For pump max Amp. | kg. |
|-----------------|-------|-------|-----------------------------|-------|
| P 02 12 202 | | 12-24 | 10 | 0,200 |



Interruttore automatico per pompe di sentina

Portata 20A. Carcassa in tecnopolimero.
Removibile per la pulizia.

Automatic switch for bilge pumps

Capacity 20A. Body manufactured in Technopolymer. Can be removed for cleaning.

| Articolo - Item | €/pc. | Volts | Portata max-Max current draw | | Activation level mm. | Deactivation level mm. |
|-----------------|-------|-------|------------------------------|-----|----------------------|------------------------|
| | | | 12V | 24V | | |
| P 02 06 620 | | 12-24 | 20 | 10 | 51 | 19 |

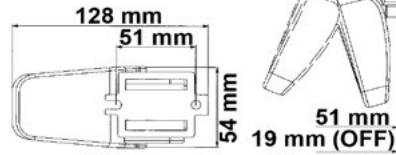

Kit completamento pompa di sentina

Provvisto di indicatore galleggiante, pannello di controllo con portafusibile e 2 scatole di fusibili di diversi amperaggi.

Float switch kit with 4 pcs.

Provided with floating gauge, control panel and fuses.

| Articolo - Item | €/Kit | kg. |
|-----------------|-------|-------|
| P 02 12 205 | | 1,150 |



Pannello

Pannello per pompe di sentina elettriche in lega leggera anodizzata. Interruttore basculante con spia luminosa AUTOMATICO-OFF-MANUALE stagno con ritorno automatico nella posizione manuale.

Panel for bilge pump

Panel for electric bilge pumps in anodised light alloy. Switch tilting with LED AUTO-MATIC-OFF-MANUAL light with automatic return to manual position.

| Articolo - Item | €/pc. | Volts | mm. |
|-----------------|-------|-------|-------|
| P 02 00 299 | | 12 | 90x50 |



Pannello di comando a 12V. per pompe di sentina

Provvisto di interruttore per utilizzo manuale ed automatico, con led e porta fusibile.

Bilge pump control panel 12V.

Provided with Leds toggle switch automatic and manual.

| Articolo - Item | €/pc. | Volts | mm. | kg. |
|-----------------|-------|-------|-------|-------|
| P 02 88 050 | | 12 | 88x50 | 0,060 |



Pannello di comando per pompe di sentina a 12V.

(provvista di fusibili intercambiabili 5A.-10A.-15A.-20A.-25A.-30A.). Interasse fori 109 x 70 mm.

Bilge pump control panel 12V.

Fuses holder with assorted fuses 5A-10A-15A-20A.-25A-30A. Center holes 109 x 70 mm.

| Articolo - Item | €/pc. | Volts | mm. | kg. |
|-----------------|-------|-------|------------|-------|
| P 02 84 125 | | 12 | 125x84x46H | 0,460 |



FILTRI DOCCE E POMPE | FILTERS

Filtri per docce e pompe di sentina

Da montare sulla tubazione.

Filter for shower or bilge pumps

Pipe installation.

| Articolo - Item | €/pc. | Portagomma Hose adaptor | mm. | kg. |
|-----------------|-------|----------------------------|---------|-------|
| N 01 18 521 | | 3/4" Ø 19,5 mm. | Ø60x90H | 0,080 |
| N 01 18 523 | | 1/2" Ø 12,7 mm. | Ø60x90H | 0,080 |



Filtro pompa

Filtro acqua di mare per il filtraggio di impurità e particelle tramite retina, al fine di rimuovere alghe e batteri nel sistema dei tubi per proteggere l'intero apparato e far sì che l'equipaggiamento di bordo lavori correttamente.

Bilge pump filter

Directly filters water suspended solids, particles and other impurities with a filter net, to reduce dirt, bacteria algae, rust, etc. in a pipe system, to protect the pipe system and equipment.

| Articolo - Item | €/pc. | Ø Raccordo uscita Output ø mm. | Ø Tubo suggerito Recommended hose size mm. | Portata suggerita Recommended input |
|-----------------|-------|-----------------------------------|---|--|
| N 01 01 191 | | D1: 25,4 (1") | 25 | 91L/min. 24 GMP US |
| | | D2: 31,8 (1-1/4") | 32 | 143L/min. 37,8 GMP US |
| | | D3: 38,1 (1-1/2") | 38 | 200L/min. 52,9 GMP US |
| N 01 00 151 | | D1: 12,7 (1/2") | 13 | 23L/min. 6 GMP US |
| | | D2: 15,9 (5/8") | 16 | 35L/min. 9 GMP US |
| | | D3: 19,1 (3/4") | 19 | 51L/min. 13 GMP US |

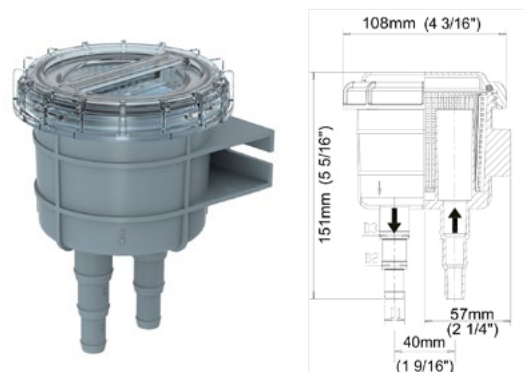
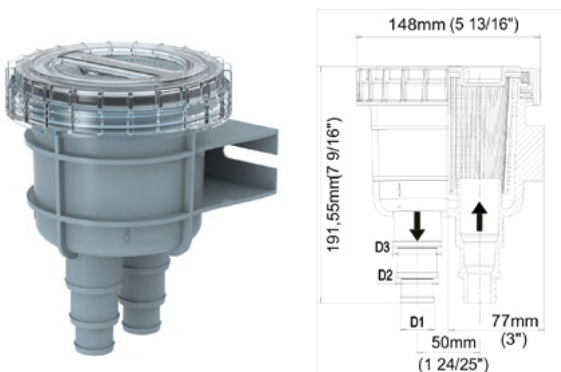

Serbatoio di espansione

Ideale per acqua potabile, per pompe autoclavi e sistemi pressurizzati.
 Fabbricato in plastica.
 Capacità 1 lt.

Tank for fresh water

Suitable for fresh water. For bilge pumps and pressurized systems.
 Manufactured in plastic.
 Capacity 1 lt.

| Articolo - Item | €/pc. | Lunghezza-Length mm. | kg. |
|-----------------|-------|----------------------|-------|
| N 01 01 024 | | 240 | 0,360 |



Serbatoio ad espansione

Pressurized accumulator tank

| Articolo - Item | €/pc. | Volume Interno Internal Volume | Pressione pre-carica Pre-charge Pressure | Pressione massima Max Operating Pressure | Valvola aria Air Fill Valve | Ø Entrata/Uscita Inlet/Outlet | mm. | kg. |
|-----------------|-------|-----------------------------------|---|---|---|----------------------------------|-----------------------|-------|
| N 01 01 205 | | 0,75 L | 10PSI/0,7BAR | 125PSI/8,6BAR | standard automotive style tire valve | 1/2" MNPT | 205 x 116 (8,1"x4,6") | 0,360 |

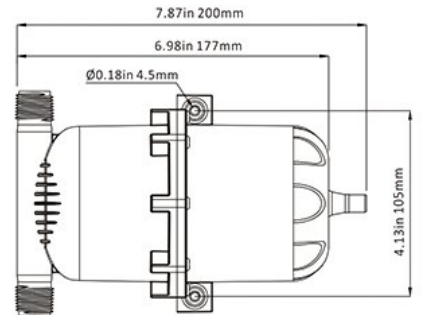
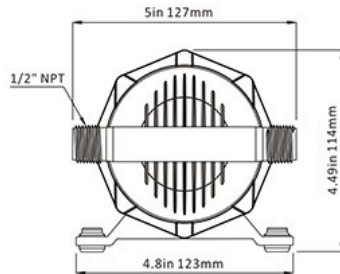

VISIT OUR B2B AREA

- CREATE A CUSTOMER ACCOUNT
- CHECK AVAILABILITY & QUANTITY OF ITEMS
- CHECK YOUR COMMERCIAL CONDITION
- PLACE YOUR ORDER
- TRACK YOUR ORDER STATUS
- TRACK YOUR PAYMENT PROCESS



WWW.TREM.NET



Fabbricate in neoprene MC97 per acqua dolce e salata (pompe di raffreddamento motore e per servizi di bordo).
 Certificate ISO 9001.

IMPRONTE IN SCALA 1:1
SOVRAPPONETE LA VOSTRA GIRANTE PER VERIFICARE LE
DIMENSIONI

Made in neopren MC97 for salt and fresh water (engine cooling pumps and other FIP applications).
 ISO 9001 quality guaranteed.

DRAWING 1:1
CHECK THE IMPELLER DIMENSION DIRECTLY ON THE
DRAWING

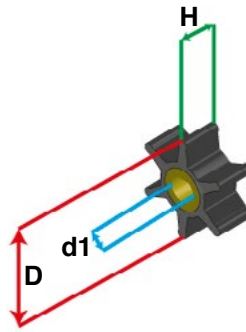

Girante

Girante ricambio Jabsco/Johnson.

Impeller

Jabsco/Johnson spare impeller.

| Articolo - Item | €/pc. | Mod. Albin Pump | Mod. Johnson | Mod. Jabsco | mm. | Materiale - Material | kg. |
|-----------------|-------|-----------------|--------------|-------------|---------------|----------------------|-------|
| P 03 32 001 | | 06-01-001 | - | 1414-001 | 32Dx8d1x12H | Neopren | 0,020 |
| P 03 40 003 | | 06-01-003 | 09-806B-1 | 4528-0001 | 39,7x9,5x19,2 | Neopren | 0,042 |
| P 03 40 002 | | 06-01-002 | 09-808B-1 | 22405-001 | 39,7x12x19,2 | Neopren | 0,028 |
| P 03 50 008 | | 06-01-008 | 09-824P-1 | 6303-0001 | 51 x 8 x 22H | Nitril oil resistant | 0,055 |
| P 03 50 009 | | 06-01-009 | 09-824P-9 | 6303-0003 | 51 x 8 x 22H | Neopren | 0,055 |
| P 03 50 007 | | 06-01-007 | - | 22799-0001 | 51x12,7x22H | Neopren | 0,055 |
| P 03 50 005 | | 06-01-005 | 09-810B-1 | 653-0001 | 51x12x22H | Neopren | 0,055 |
| P 03 50 006 | | 06-01-006 | 09-1026B-1 | 673-0001 | 51x12,7x22H | Neopren | 0,052 |
| P 03 50 010 | | 06-01-010 | - | 18653-0001 | 51x12x22H | Neopren | 0,071 |
| P 03 50 011 | | 06-01-011 | - | 18673-0001 | 51x12,7x22H | Neopren | 0,071 |

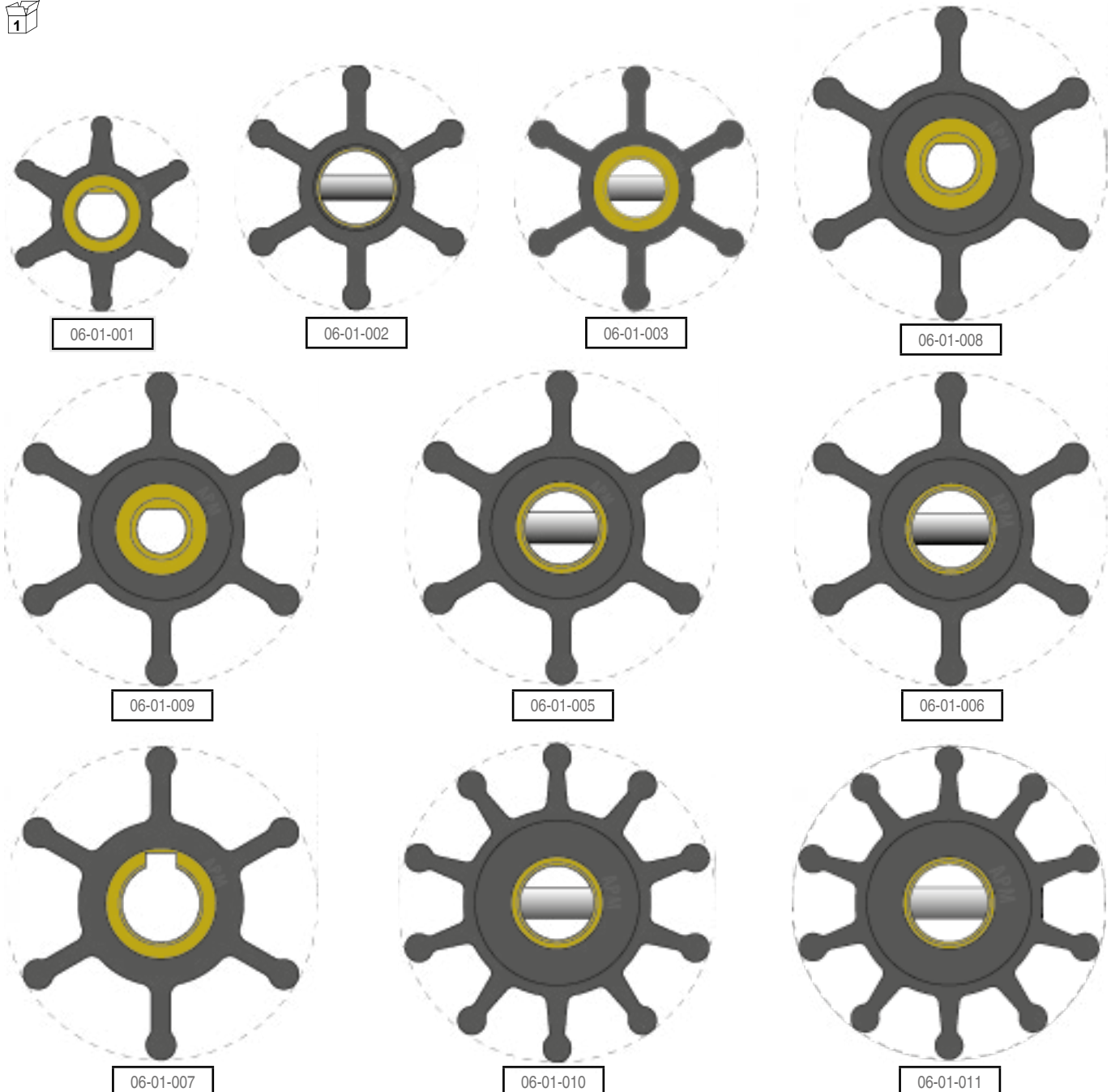



Girante

Girante ricambio Jabsco/Johnson.

Impeller

Jabsco/Johnson spare impeller.

| Articolo - Item | €/pc. | Mod. pompa | Mod. Albin Pump | Mod. Johnson | Mod. Jabsco | ↑ mm. | kg. |
|-----------------|-------|------------|-----------------|--------------|-------------|----------------|-------|
| P 03 57 012 | | F5 | 06-01-012 | 09-1027B-1 | 1210-0001 | 57Dx16d1x31,5H | 0,112 |
| P 03 57 014 | | F6 | 06-01-014 | 09-812B-1 | 13554-0001 | 57Dx16d1x48,2H | 0,119 |
| P 03 65 050 | | F7 | 06-01-021 | 09-1028B-1 | 920-0001 | 65Dx16d1x50H | 0,176 |
| P 03 65 037 | | F7 | 06-01-017 | - | 11979-0001 | 65Dx16d1x37H | 0,128 |
| P 03 65 076 | | - | 06-02-024 | - | 17018-0001 | 65Dx16d1x76H | 0,261 |
| P 03 65 022 | | - | 06-02-022 | - | 31130-0061 | 65Dx15,8d1x68H | 0,244 |
| P 03 65 023 | | - | 06-02-023 | - | 17937-0001 | 65Dx15,8d1x50H | 0,183 |



06-01-012

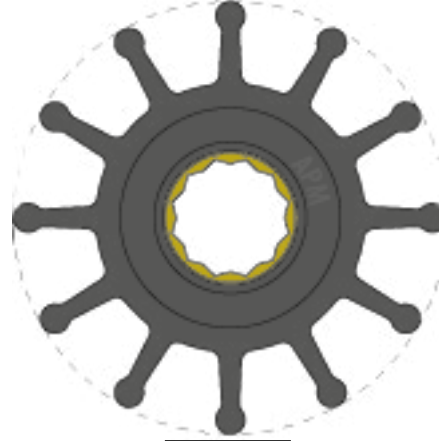

06-01-014

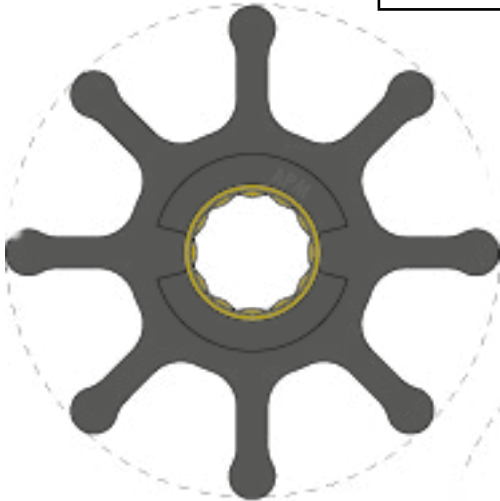

06-01-021

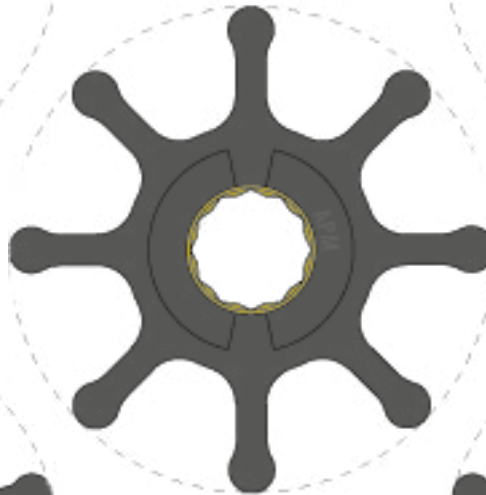

06-01-017

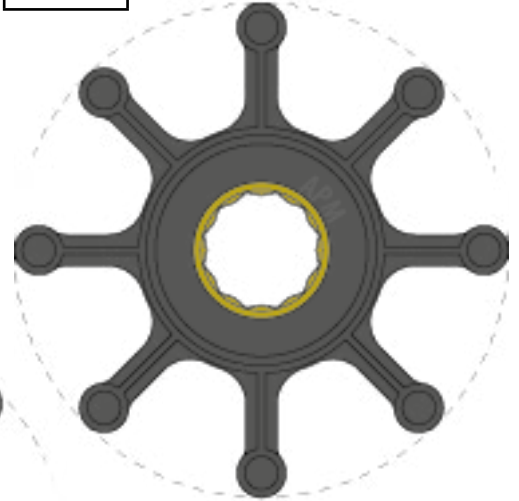

06-02-024

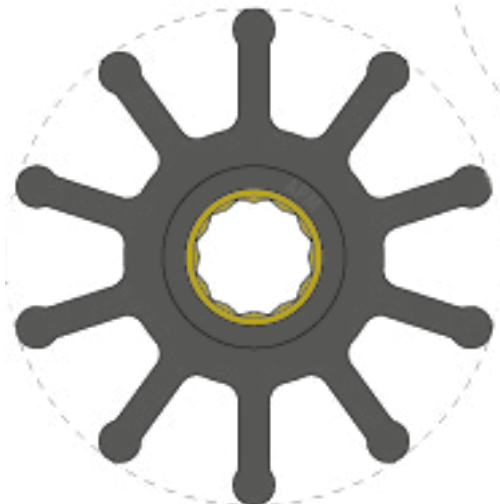

06-02-022

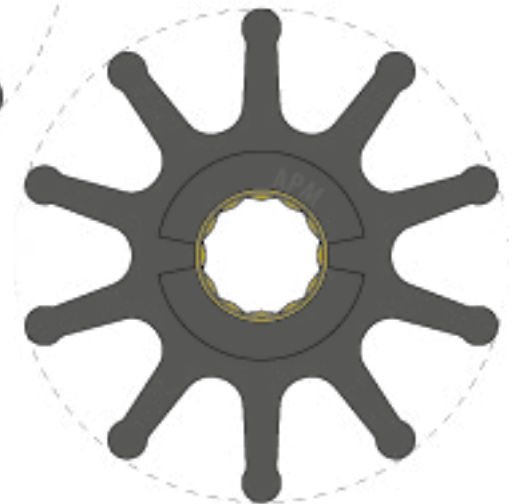

06-02-023



Girante 65 mm.

Girante ricambio Jabsco/Johnson.

Impeller 65 mm.

Jabsco/Johnson spare impeller.

| Articolo - Item | €/pc. | Mod. pompa | Mod. Albin Pump | Sherwood | Mod. Johnson | Mod. Jabsco | ↑ mm. | kg. |
|-----------------|-------|------------|-----------------|----------|--------------|-------------|------------------|-------|
| P 03 65 051 | - | - | 06-01-019 | - | - | 18327-0001 | 65Dx15,8d1x51H | 0,185 |
| P 03 65 080 | - | F75 | 06-01-020 | - | 09-821BT-1 | - | 65,8Dx25d1x80H | 0,185 |
| P 03 65 041 | - | - | 06-01-018 | 10615K | 09-702B-1 | 18948-0001 | 65Dx15,8d1x41,5H | 0,178 |



TABELLA COMPARATIVA

COMPARATIVE TABLE

| TR.EM. | Pag. | Albin | JMP | Jabsco | Johnson | Sherwood | Volvo Penta | Yanmar |
|-------------|------|-----------|---------|------------|-------------|----------|-------------|--------------|
| P 03 32 001 | 435 | 06-01-001 | 6000.01 | 1414-001 | | | | 124170-42070 |
| P 03 40 002 | 435 | 06-01-002 | 7000.01 | 22405-001 | 09-808B-1 | | 875583 | |
| P 03 40 003 | 435 | 06-01-003 | 7001.01 | 4528-0001 | 09-806B-1 | 9979K | 803729 | 104211-42070 |
| P 03 50 005 | 435 | 06-01-005 | 7050.01 | 653-0001 | 09-810B-1 | | | |
| P 03 50 006 | 435 | 06-01-006 | 7051.01 | 673-0001 | 09-1026B-1 | | 3593659 | |
| P 03 50 007 | 435 | 06-01-007 | 7052.01 | 22799-0001 | | | | 124223-42091 |
| P 03 50 008 | 435 | 06-01-008 | 7053.01 | 6303-0001 | 09-824P-1 | | | |
| P 03 50 009 | 435 | 06-01-009 | 7053.02 | 6303-0003 | 09-824P-9 | | | |
| P 03 50 010 | 435 | 06-01-010 | 7070.01 | 18653-0001 | | | | |
| P 03 50 011 | 435 | 06-01-011 | 7071.01 | 18673-0001 | | | | |
| P 03 57 012 | 436 | 06-01-012 | 7100.01 | 1210-0001 | 09-1027B-1 | | 825940 | 129470-42530 |
| P 03 57 014 | 436 | 06-01-014 | 7136.01 | 13554-0001 | 09-812B-1 | | 3588914 | |
| P 03 62 032 | 438 | 06-01-016 | 7192.01 | 18838-0001 | 09-701B-1 | 9959K | | |
| P 03 65 037 | 436 | 06-01-017 | 7200.01 | 11979-0001 | | | | 122610-42021 |
| P 03 65 041 | 437 | 06-01-018 | 7300.01 | 18948-0001 | 09-702B-1 | 10615K | | |
| P 03 65 051 | 437 | 06-01-019 | 7352.01 | 18327-0001 | | 15000K | | |
| P 03 65 080 | 437 | 06-01-020 | 7376.01 | | 09-821BT-1 | | 876771 | 119574-42550 |
| P 03 65 050 | 436 | 06-01-021 | 7400.01 | 920-0001 | 09-1028B-1 | 18200K | 877061 | 123325-42020 |
| P 03 65 022 | 436 | 06-02-022 | 7420.01 | 31130-0061 | | | | |
| P 03 65 023 | 436 | 06-02-023 | 7426.01 | 17937-0001 | | | 3588475 | |
| P 03 65 076 | 436 | 06-02-024 | 7446.01 | 17018-0001 | | | 3593573 | |
| P 03 82 073 | 438 | 06-02-025 | 7600.01 | 18958-0001 | 09-704BT-1 | 17000K | | |
| P 03 95 027 | 439 | 06-02-027 | 8000.01 | 836-0001 | 09-1029B | | | |
| P 03 95 063 | 439 | 06-02-028 | 8100.01 | 17935-0001 | 09-819B | | 875660 | |
| P 03 95 029 | 439 | 06-02-029 | 8200.01 | 6760-0001 | 09-802B | | 842857 | 125613-42762 |
| P 03 95 088 | 438 | 06-02-030 | 8300.01 | 17370-0001 | | | | |
| P 03 95 089 | 439 | 06-02-031 | 8301.01 | 17936-0001 | 09-814B | | 875660 | |
| P 03 95 095 | 438 | 06-02-032 | 8326.01 | 17938-0001 | | | 3830459 | |
| P 03 95 101 | 438 | 06-02-033 | 8350.01 | | 09-705BT-01 | 18000K | | |

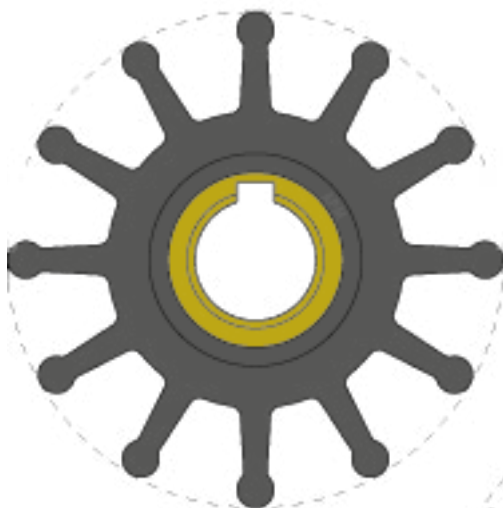

06-01-019

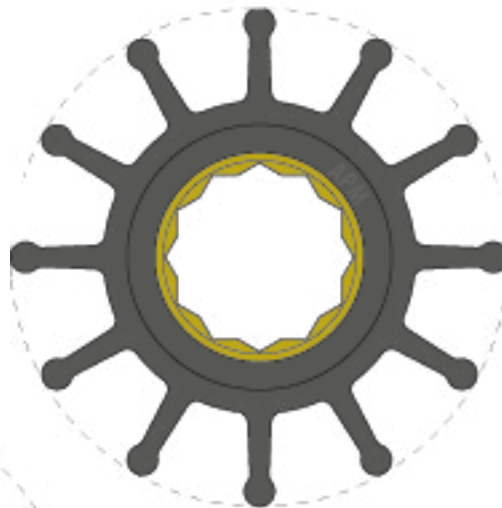

06-01-020

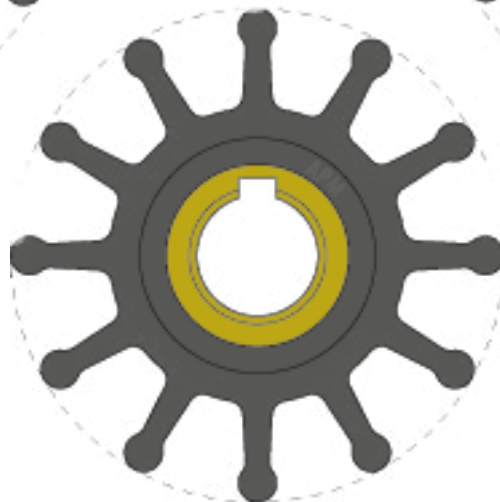

06-01-018



Girante

Girante ricambio Jabsco/Johnson.

Impeller

Jabsco/Johnson spare impeller.

| Articolo - Item | €/pc. | Mod. Albin Pump | Mod. Johnson | Mod. Sherwood | Mod. Jabsco | ↑ mm. | kg. |
|-----------------|-------|-----------------|--------------|---------------|-------------|------------------|-------|
| P 03 62 032 | | 06-01-016 | 09-701B-1 | 9959K | 18838-0001 | 62,5Dx16d1x32H | 0,163 |
| P 03 82 073 | | 06-02-025 | 09-704BT-1 | 17000K | 18958-0001 | 82,4Dx20d1x73,4H | 0,481 |
| P 03 95 101 | | 06-02-033 | 09-705BT-01 | 18000K | - | 95Dx24d1x101,5H | 0,716 |
| P 03 95 088 | | 06-02-030 | - | - | 17370-0001 | 95Dx25d1x88,8H | 0,690 |
| P 03 95 095 | | 06-02-032 | - | - | 17938-0001 | 95Dx25d1x95H | 0,665 |

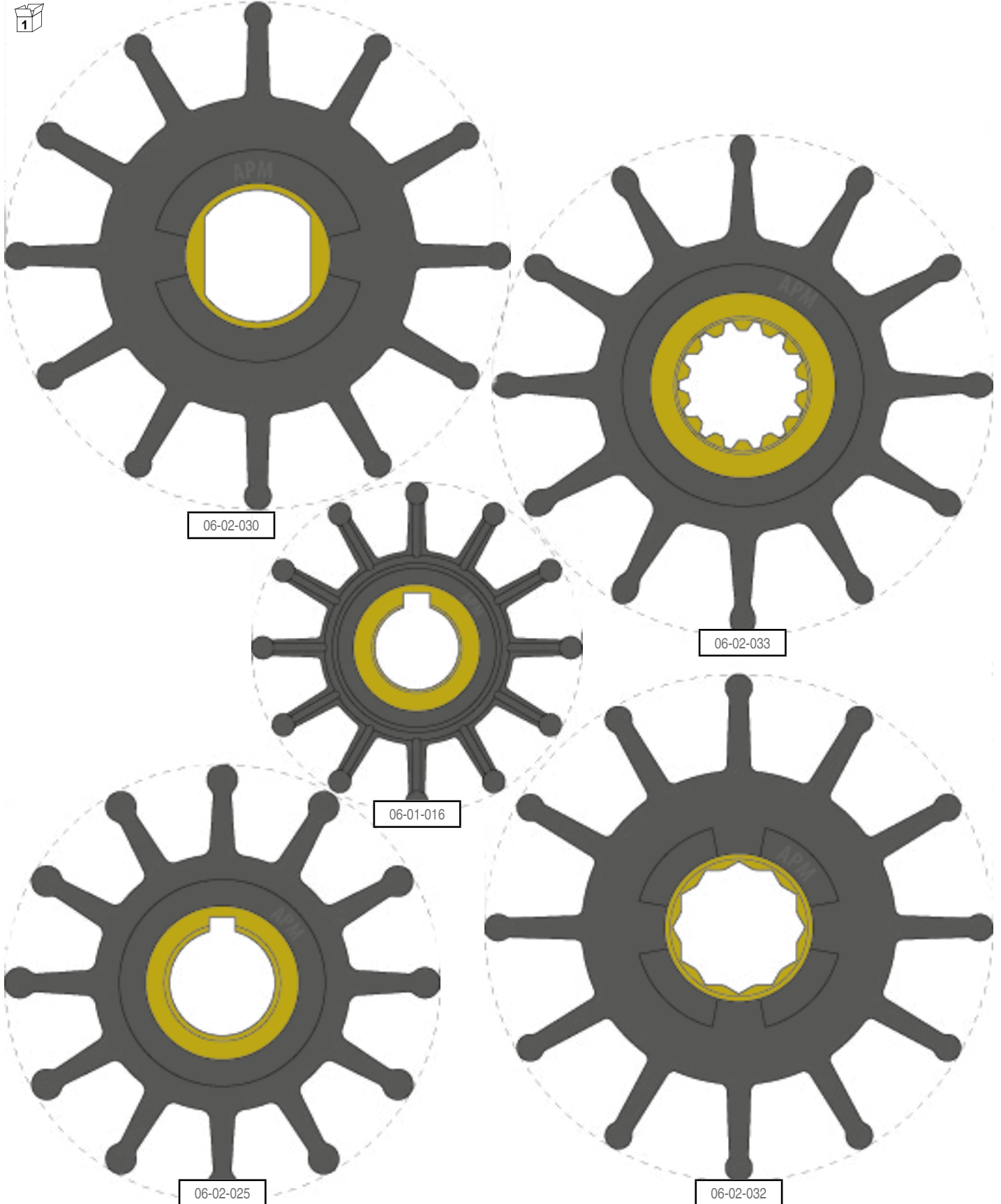

Girante 95 mm.

Girante ricambio Jabsco/Johnson.

Impeller 95 mm.

Jabsco/Johnson spare impeller.

| Articolo - Item | €/pc. | Mod. pompa | Mod. Albin Pump | Mod. Johnson | Mod. Jabsco | ↑ mm. | kg. |
|-----------------|-------|------------|-----------------|--------------|--------------------------------|----------------|-------|
| P 03 95 063 | | F8 | 06-02-028 | 09-819B | 836-0001(EU)/17935-0001(USA) | 95Dx25d1x63H | 0,474 |
| P 03 95 089 | | F9 | 06-02-031 | 09-814B | 21676-0001(EU)/17936-0001(USA) | 95Dx25d1x88,8H | 0,690 |
| P 03 95 027 | | F8 | 06-02-027 | 09-1029B | 836-0001(EU)/17935-0001(USA) | 95Dx25d1x63H | 0,442 |
| P 03 95 029 | | F9 | 06-02-029 | 09-802B | 6760-0001 | 95Dx25d1x88,8H | 0,586 |

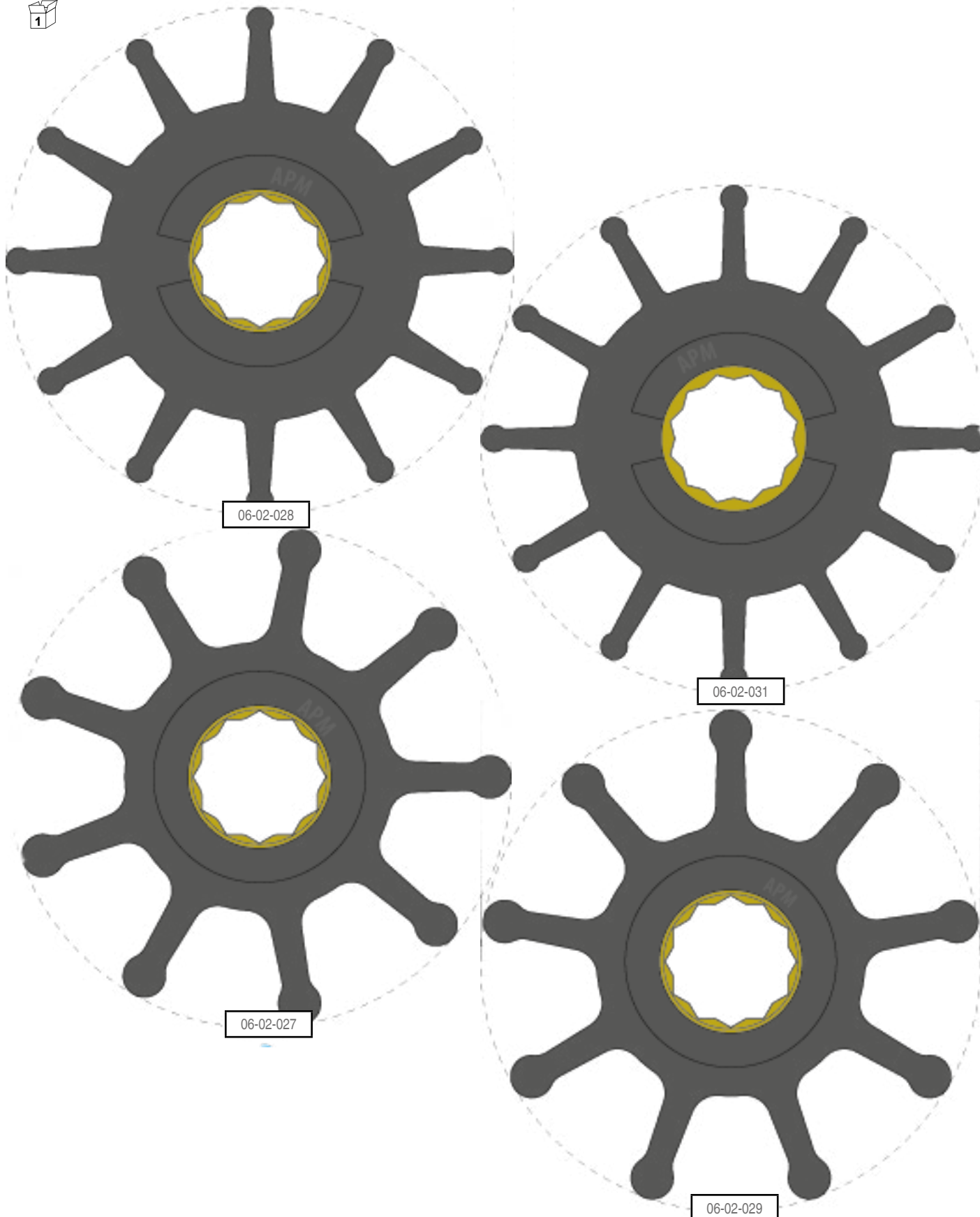

WC ELETTRICI | ELECTRIC TOILETS

WC marino elettrico

Realizzato in porcellana bianca. Sedile in plastica. Fornito con interruttore per il comando della pompa. Portagomma entrata e uscita Ø 25 mm.

Electric marine toilet

China white bow. Plastic seat. Complete with pump control switch. Inlet & discharge hose adapter Ø 25 mm.

| Articolo - Item | €/pc. | Alimentazione-Power supply |
|-----------------|-------|----------------------------|
| Z 18 08 420 | | 12V-18A |



COMPLETO DI-COMPLETE WITH



Art. Z1808055 (pag. 443) Art. Z1812000 (pag. 443) Art. Z1808001 (pag. 442) Art. Z1803825 (pag. 442)

SUGGESTED ITEM



Art. Z1812035 (pag. 443)

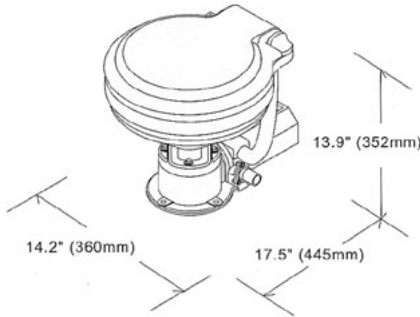

WC marino elettrico «Large»

Realizzato in porcellana bianca. Sedile in plastica. Fornito con interruttore per il comando della pompa. Portagomma entrata e uscita Ø 25 mm. Tazza grande.

Electric marine toilet «Large»

China white bow. Plastic seat. Complete with pump control switch. Inlet & discharge hose adapter Ø 25 mm.

| Articolo - Item | €/pc. | Alimentazione-Power supply |
|-----------------|-------|----------------------------|
| Z 18 08 041 | | 12V-18A |



COMPLETO DI-COMPLETE WITH



Art. Z1814040 (pag. 443) Art. Z1812000 (pag. 443) Art. Z1808001 (pag. 442) Art. Z1803825 (pag. 442)

SUGGESTED ITEM



Art. Z1812035 (pag. 443)

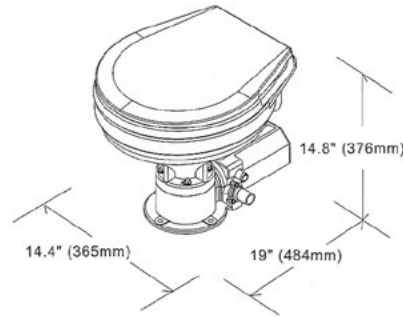

WC marino elettrico silenzioso Silent electric marine toilet

Realizzato in porcellana bianca. Sedile in plastica. Fornito con interruttore per il comando della pompa. La particolare carenatura nasconde la pompa maceratrice e i tubi di carico e scarico. Portagomma entrata Ø 20 mm. e uscita Ø 35 mm.

China white bow. Plastic seat. Complete with pump control switch. The particular fairing hides the macerating pump and the inlet and discharge hoses. Hose adapter: Inlet Ø 20 mm. - Discharge Ø 35 mm.

| Articolo - Item | €/pc. | Alimentazione-Power supply |
|-----------------|-------|----------------------------|
| Z 18 12 355 | | 12V-18A |



COMPLETO DI-COMPLETE WITH



Art. Z1814040 (pag. 443) Art. Z1812000 (pag. 443) Art. Z1808001 (pag. 442)

SUGGESTED ITEM



Art. Z1812035 (pag. 443)

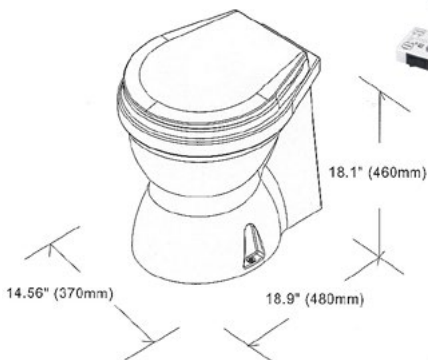

WC marino elettrico silenzioso Silent electric marine toilet

- Filtro e pompa di pressione inclusi
- Pannello di controllo a 4 funzioni incluso
- Raccordi: attacchi 3/4" (19mm), 1" (25mm)
- Fusibili 15A
- Seduta e coperchio con chiusura soft
- Intake rinse pump & strainer included
- 4-way flush control panel included
- Fitting: connections 3/4" (19mm), 1" (25mm)
- Fuse size 15A
- Slow-close seat and cover

| Articolo - Item | €/pc. | Sedile - Seat | Volts | Amp. | kg. |
|-----------------|-------|-------------------|-------|------|--------|
| Z 18 12 363 | | Z1800925 Plastica | 12 | 9 | 25,700 |



COMPLETO DI-COMPLETE WITH



Art. Z1808055 (pag. 443) Art. Z1812000 (pag. 443) Art. Z1808001 (pag. 442)

SUGGESTED ITEM



Art. Z1812035 (pag. 443)



WC manuale

Fornito con tazza piccola, seduta e coperchio in plastica.
Connessioni 19mm ingresso, 38mm scarico.

Manual marine toilet

Supplied with small bowl & standard plastic seat & cover.
Fitting: connections for 3/4" (19mm) ID inlet hose, 1-1/2" (38mm) ID discharge hose.

| Articolo - Item | €/pc. | Sedile-Seat | kg. |
|-----------------|-------|---------------------------|--------|
| Z 18 08 011 | | Z1800925 Plastica-Plastic | 13,500 |



COMPLETE WITH



Art. Z1808055 (pag. 442)

SUGGESTED ITEM



Art. Z1800032 (pag. 442)

Art. Z1812035 (pag. 443)

Art. Z1800040 (pag. 443)

TANK (pag. 445)

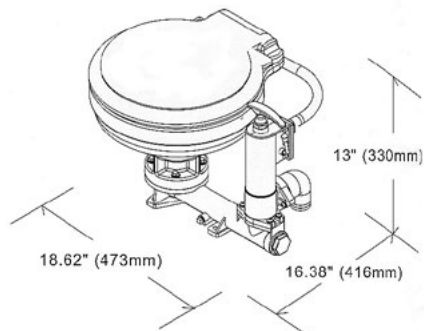

WC comando manuale

Tazza in porcellana bianca finissima con pompa in nylon a stantuffo.
Può essere installato sotto o sopra livello. Tubi d'entrata da 3/4" - uscita e d'uscita da 1 1/2".
La pompa può essere montata a destra o a sinistra. base ø 126 mm.

Manual marine toilet

China white bow with double action pump in nylon. Fitting above or below the waterline.
Toilet mechanism can be installed on the right or left side of the bowl.
Inlet 3/4" (19,5 mm.), outlet 1" 1/2 (38 mm.).

| Articolo - Item | €/pc. | Sedile-Seat | kg. |
|-----------------|-------|-------------|--------|
| Z 18 25 003 | | - | 10,500 |

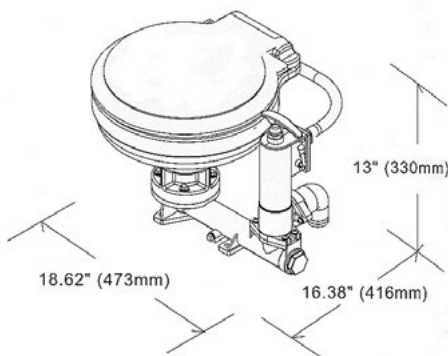

SUGGESTED ITEM



Art. Z1812035 (pag. 443)

Art. Z1800040 (pag. 443)

TANK (pag. 445)

WC chimico «Portatile»

Completo di vasca di recupero.
Fabbricato in materia plastica

Chemical toilet

With tank.
Manufactured in plastic material.

| Articolo - Item | €/pc. | mm. | Lt. | kg. |
|-----------------|-------|----------------|-----|-------|
| Z 18 00 436 | | H415xL410xP355 | 20 | 6,070 |



Particolari di ricambio per WC elettrici

Spare parts for electric toilets

| Articolo - Item | €/pc. | Mod. | Descrizione-Description |  | kg. |
|-----------------|-------|------|--|---|-------|
| Z 18 00 018 | | A | Girante centrifuga - Centrifugal impeller | 1 | 0,020 |
| Z 18 00 019 | | B | Scatola maceratore - Macerator housing | 1 | 0,035 |
| Z 18 00 021 | | C | Guarnizione - Gasket | 1 | 0,005 |
| Z 18 00 023 | | D | Guarnizione - Gasket | 1 | 0,005 |
| Z 18 00 024 | | E-L | Scarico a 90° e guarnizione - Discharge port | 1 | 0,010 |
| Z 18 00 028 | | F | Guarnizione - Gasket | 1 | 0,085 |
| Z 18 00 029 | | G | Girante flessibile - Flexible impeller | 1 | 0,030 |
| Z 18 00 031 | | H | Motore - Motor | 1 | 2,020 |
| Z 18 00 044 | | I | Flangia per base - Base packing | 1 | 0,020 |

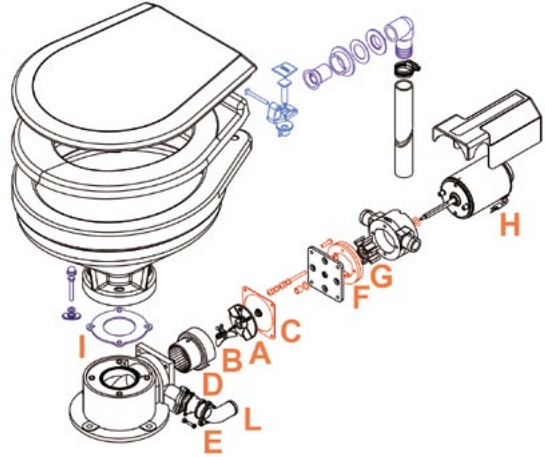
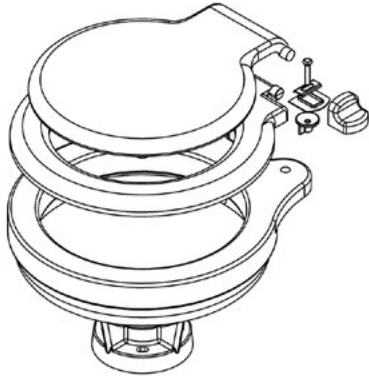

Base di ricambio per WC elettrico

Base kit for electric toilet

| Articolo - Item | €/pc. |  | kg. |
|-----------------|-------|--|-------|
| Z 18 03 825 | | 1 | 0,025 |

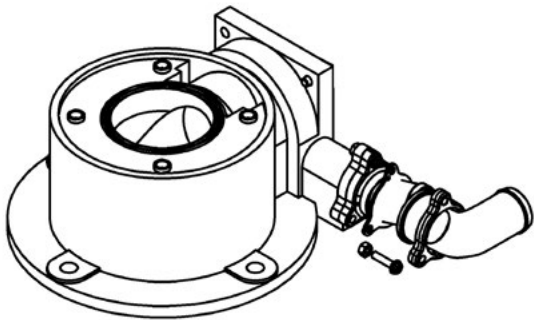

Kit riparazione per WC manuale (Z1808011) Repair kit for manual toilets (Z1808011)

| Articolo - Item | €/kit. |  | kg. |
|-----------------|--------|--|-------|
| Z 18 00 032 | | 1 | 0,150 |

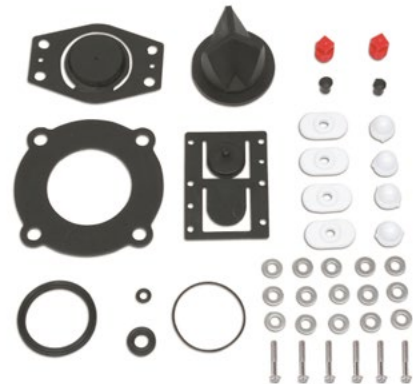

Pompa per Wc elettrici

Pump for electric toilets

| Articolo - Item | €/pc. | Tubo-Hose Ø mm. | Amp. | Dim. fusibile Fuse size |  | kg. |
|-----------------|-------|--------------------|------|----------------------------|---|-------|
| Z 18 08 001 | | 1" (25,4mm) | 18 | 30 Amp. | 1 | 2,880 |



Pompa a piede

Diaphragm foot pump

| Articolo - Item | €/pc. | Tubo-Hose Ø mm. | Capacità Capacity | mm. |  | kg. |
|-----------------|-------|--------------------|----------------------|-------------------|---|-------|
| Z 18 70 701 | | 1/2" (13mm) | 240 GPH (908LPH) | 236,8x152,6x123,5 | 1 | 1,180 |



Maceratore per WC

Ideale per svuotare il serbatoio dalle acque nere. Entrata Ø 39 mm. - uscita Ø 25 mm.

Macerator pump for toilet

To empty black water tanks. Inlet Ø 39 mm., outlet Ø 25 mm.

| Articolo - Item | €/pc. | Volts | Lt./min. | mm. | kg. |
|-----------------|-------|-------|----------|-------------|-------|
| Z 18 12 035 | | 12 | 45 | 355x133x110 | 2,240 |
| Z 18 24 035 | | 24 | 45 | 355x133x110 | 2,700 |

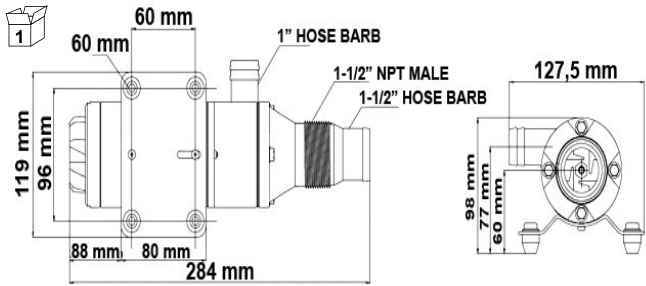

Kit trasformazione WC

Da manuale a elettrico. Completo di pompa, maceratore, base rotonda, portagomma per non sostituire i raccordi e le tubazioni esistenti, pannello elettrico, tubo Ø 25 mm. Viteria inclusa. Si adatta ai WC Jabsco, TMC, AAA, Raritan, Groco, Wilcox, ecc.

Toilet conversion kit

The manual toilet can be converted into an electric toilet. Complete with pump, macerator, round base, hose adapter, electric panel, hose Ø 25 mm. Fitting screws included. Fits Jabsco, TMC, AAA, Raritan, Groco, Wilcox, ecc. toilets.

| Articolo - Item | €/pc. | Volts | A mm. | B Ø mm. | C Ø mm. | D mm. |
|-----------------|-------|-------|-------|---------|---------|-------|
| Z 18 00 040 | | 12 | 352 | 178 | 126 | 70 |
| Z 18 24 040 | | 24 | 352 | 178 | 126 | 70 |

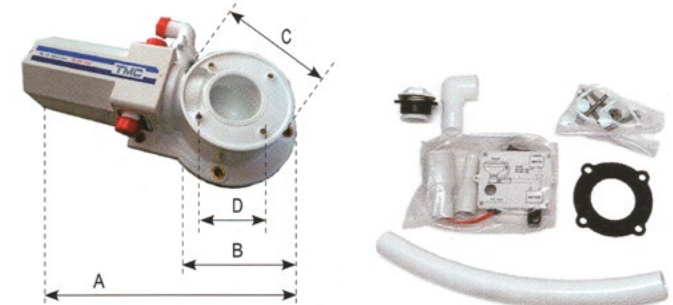

Pannello elettrico

Con interruttore e fusibile (25A 12V-15A 24V) per azionamento WC elettrico.

Electric panel

With control switch and fuse (25A 12V-15A 24V) for electric toilet operation.

| Articolo - Item | €/pc. | mm. |
|-----------------|-------|--------|
| Z 18 12 000 | | 110x90 |



Sifone

In nylon per WC. Indispensabile quando il WC viene montato sotto la linea di galleggiamento.

Vented loop

Manufactured in nylon for marine toilet. Necessary when the toilet is mounted below the waterline.

| Articolo - Item | €/pc. | Mod. |
|-----------------|-------|--|
| Z 18 45 019 | | Portagomma in nylon-Nylon hose adapter Ø 19 mm. (1/2) carico |
| Z 18 32 025 | | Portagomma inox-SS hose adapter Ø 25 mm. (1") scarico |
| Z 18 45 038 | | Portagomma in nylon-Nylon hose adapter Ø 38 mm. (1" 1/2) scarico |



Z1845019-Z1845038



Z1832025

Coperchio di ricambio per WC **Spare cover for marine toilet**

In legno laccato bianco.

Manufactured in white lacquered wood.

| Articolo - Item | €/pc. |
|-----------------|-------|
| Z 18 08 055 | |

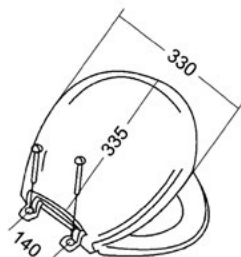

Coperchio di ricambio per WC **Spare cover for marine toilet**

In legno laccato bianco.

Manufactured in white lacquered wood.

| Articolo - Item | €/pc. |
|-----------------|-------|
| Z 18 14 040 | |

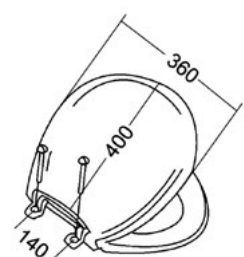

NOTIZIE UTILI PER INSTALLARE IL WC E L'IMPIANTO ACQUE NERE USEFUL INFORMATION FOR INSTALLING THE WC AND THE WASTE WATER SYSTEM

- I WC marini TMC possono essere installati sia sopra che sotto la linea di galleggiamento.
- Collegare il tubo di ingresso usando un tubo da 19 mm (3/4"). Assicurarsi che tutti i collegamenti di ingresso siano ermetici e privi di curve o restringimenti taglienti.
- Collegare il tubo da 25 mm (1") alla porta di scarico ed effettuare collegamenti adeguati al serbatoio di contenimento o ad altro sistema di scarico. Evitare curve o restringimenti taglienti.
- Per l'installazione sopra la linea di galleggiamento, potrebbe essere necessario installare una valvola di controllo (opzionale) nella linea di aspirazione dell'acqua di lavaggio per garantire un rapido innesco della pompa. Per trattenere l'acqua nell'ampolla, realizzare un anello nella linea di scarico a circa 20 cm (8") sopra la base dell'ampolla.
- Se il WC si trova al di sotto della linea di galleggiamento, è necessario installare un sifone vented loop con sfiato da 19 mm (3/4") nelle tubazioni di ingresso. Il sifone vented loop deve essere posizionato in modo che rimanga sempre al di sopra della linea di galleggiamento.
- I sifoni vented loop devono essere installati al di sotto della linea di galleggiamento per prevenire il riflusso dei rifiuti.
- I rifiuti possono essere prima immagazzinati nel serbatoio di contenimento e poi scaricati negli appositi impianti di raccolta in porto.

- TMC Marine toilets may be installed above or below the waterline.
- Connect inlet hose using 19 mm (3/4") ID hose. Make sure all inlet connections are airtight and free of sharp bends or restrictions.
- Connect 25 mm (1") hose to discharge port and make suitable connections to holding tank or other discharge system. Avoid sharp bends or restrictions.
- For above waterline installation, a check valve (optional) may have to be installed in the flush water intake line to ensure rapid pump priming. To retain water in bowl, make a loop in the discharge line about 20 cm (8 inches) above base of bowl.
- If the toilet is, or can be, below waterline at any normal (including static) attitude of vessel heel and/or trim, a 19 mm (3/4") vented loop fitting must be installed in the inlet pipe work. The vented loop fitting must be positioned so it always remains above the waterline at all angles of heel and trim.
- Vented loops installed below waterline are required to prevent backflow of the waste.
- The waste can be stored in the holding tank first then discharged to pump out station at the port.

Fig. 1 Sotto la linea di galleggiamento-Below water line

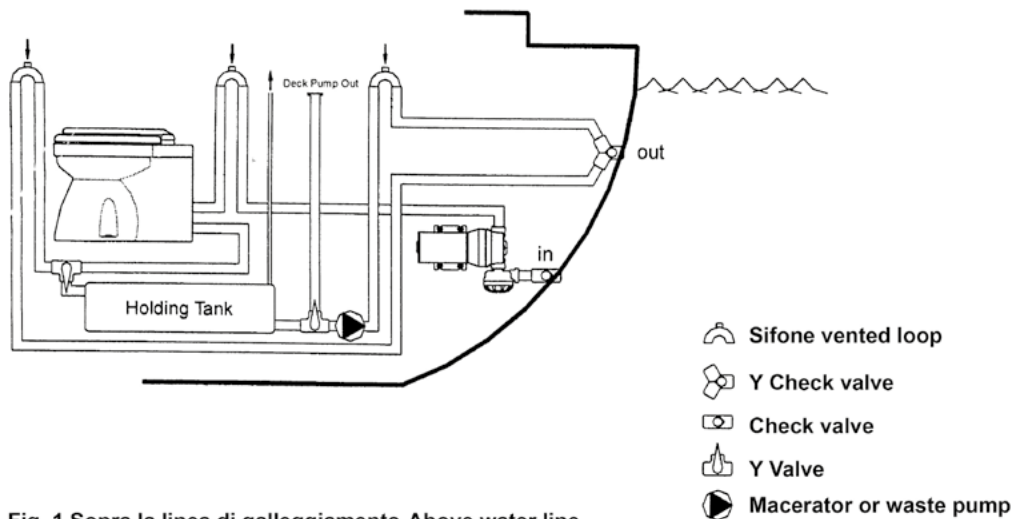
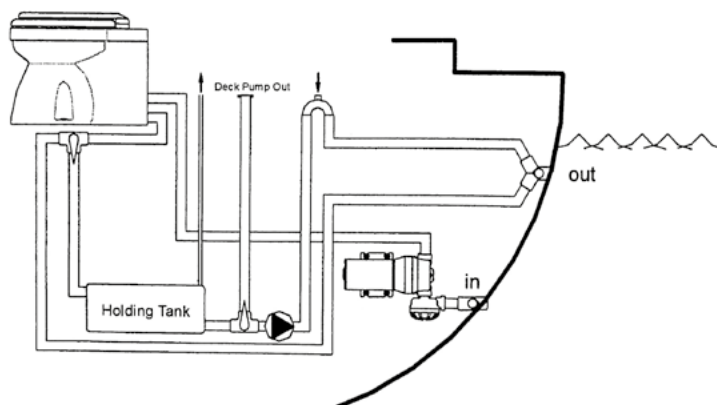

Fig. 1 Sopra la linea di galleggiamento-Above water line



Serbatoi acque nere

Serbatoi in polietilene rigido per acque nere. Sono completi di 8 fori sulle due testate, da 3/4" - 1" 1/2 per carico, scarico e sfiato. Certificati in accordo con norme ISO 8099.

| Articolo - Item | €/pc. | Lt. | A mm. | B mm. | H mm. |
|-----------------|-------|-----|-------|-------|------------------------------|
| N 01 80 047 | | 47 | 480 | 400 | 260 rettangolare-rectangular |
| N 01 80 077 | | 77 | 480 | 800 | 200 |
| N 01 80 092 | | 92 | 580 | 800 | 200 |

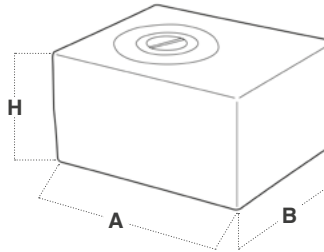

Waste tanks

Manufactured in polyethylene. With 8 joints 3/4" - 1" 1/2 to fill and drain. In compliance with ISO 8099 Specification.

COMPLETE WITH



Art. N0131130 (pag. 422)

SUGGESTED ITEM



RACCORDI-CONNECTIONS (pag. 422)



Art. Z1812035 (pag. 443)



Art. L3110025 (pag. 286)

Serbatoio acque nere con maceratore incorporato

Fornito montato e pronto all'installazione. Compatibile con tutti i WC in commercio. Completo di maceratore. Provvisto di filetti femmina di carico, scarico e sfiato. Provvisto di flangia 5 fori preforata. Completo di valvola per poter staccare il maceratore in caso di manutenzione. Fabbricati secondo la ISO 8099.

Waste water tank with built-in soaker

Ready for installation. Fits all toilet systems. Complete with electric macerator. Protection for sensor level. Complying with ISO 8099.

| Articolo - Item | €/kit. | A cm. | B cm. | H cm. | Lt. | Ø Uscita Outlet mm. | Volts |
|-----------------|--------|-------|-------|-------|-----|---------------------|-------|
| N 01 48 080 | | 47 | 39 | 26,50 | 48 | 25 | 12 |

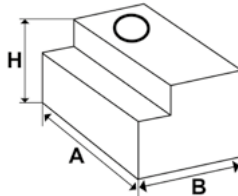

COMPLETO DI-COMLETE WITH



Art. P1812035 (pag. 443)

VALVOLA (pag. 445)

NIPLES (pag. 445)

ANGOLO (pag. 445)

Art. N4650006 (pag. 445)

SUGGESTED ITEMS



Art. L3110025 (pag. 286)

TUBI (pag. 453)

RACCORDI (pag. 422)

Valvola di non ritorno

Non-return valve

| Articolo - Item | €/pc. | Ø |
|-----------------|-------|--------|
| 461215234 | | 1" 1/2 |



Niples

Niples

| Articolo - Item | €/pc. | Ø |
|-----------------|-------|--------|
| 460215005 | | 1" 1/2 |



Angolo

Elbow connection

| Articolo - Item | €/pc. | Ø | Ø mm. |
|-----------------|-------|--------|-------|
| 469050112 | | 1" 1/2 | 50 |



Tubo pescante

Suction pipe

| Articolo - Item | €/pc. | Ø mm. | Lunghezza-Length mm. |
|-----------------|-------|-------|----------------------|
| N 46 50 006 | | 50 | 140 |



Valvola a sfera

Fabbricata in ottone.
Passaggio totale F/F.

Ball valve

Manufactured in brass
Female/Female.

| Articolo - Item | €/pc. | mm. | kg. |
|-----------------|-------|--------|-----|
| N 01 80 025 | | 1" | |
| N 01 80 038 | | 1" 1/2 | |



Portagomma maschio

Male hose adapter

| Articolo - Item | €/pc. | Filetto Threading | H. Filetto Threading mm. | Portagomma Ø mm. | Portagomma H mm. |
|-----------------|-------|-------------------|--------------------------|------------------|------------------|
| N 01 56 040 | | 1" 1/2 | 16 | 38 | 42 |



Valvola a sfera a «T»

180° leva lunga.

«T» Ball valve

180° long lever

| Articolo - Item | €/pc. | Mod. | kg. |
|-----------------|-------|--------|-----|
| N 01 18 138 | | F 3/8" | |

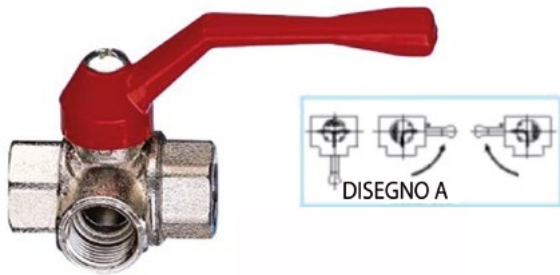

Valvola a sfera femmina/femmina

Realizzata in PVC.

Ball valve femme/female

Manufactured in PVC.

| Articolo - Item | €/pc. | Mod. | kg. |
|-----------------|-------|------|-------|
| N 01 12 182 | | 3/4" | 0,140 |
| N 01 12 186 | | 2" | 0,800 |



Manicotto ridotto

Barbed male stem adaptor

| Articolo - Item | €/pc. | €/Box | Ø grande-large mm. | Ø piccolo-small mm. | kg. |
|-----------------|-------|-------|--------------------|---------------------|-----|
| N 01 16 020 | | | 20 | 16 | |



Raccordo a «T»

«T» Hose connector

| Articolo - Item | €/pc. | €/Box | Ø mm. | kg. |
|-----------------|-------|-------|-------|-----|
| N 01 00 016 | | | 16 | |
| N 01 00 020 | | | 20 | |
| N 01 00 025 | | | 25 | |



Valvola di non ritorno

Fabbricata in nylon

One-way hose connector

Manufactured in nylon.

| Articolo - Item | €/pc. | Portagomma-Hose adaptor | | Mod. | kg. |
|-----------------|-------|-------------------------|--|---------------|-------|
| | | Ø mm. | | | |
| N 26 11 581 | | 25/38 | | in linea-line | 0,100 |



Valvola di non ritorno a tre vie Non-return valve 3 ways

| Articolo - Item | €/pc. | Per tubo-For hose | | Mod. | kg. |
|-----------------|-------|-------------------|--|--------------|-------|
| | | Ø mm. | | | |
| N 26 01 186 | | 25-1" | | 3 vie-3 ways | 0,160 |
| N 26 02 186 | | 38-1 1/2" | | 3 vie-3 ways | 0,180 |



Scarico a mare

Seacock

Fabbricato in nylon, indicata per scarico acqua dei pozzetti. Manufactured in strong plastic material.

| Articolo - Item | €/pc. | A mm. | B mm. | C mm. | D mm. | Colore Colour |
|-----------------|-------|-------|-------|-------|-------|---------------|
| N 28 30 040 | 41,5 | 23 | 31 | 80 | Black | |
| N 28 30 150 | 41,5 | 23 | 31 | 205 | Black | |
| N 28 23 040 | 41,5 | 23 | 31 | 80 | White | |
| N 28 23 150 | 41,5 | 23 | 31 | 205 | White | |

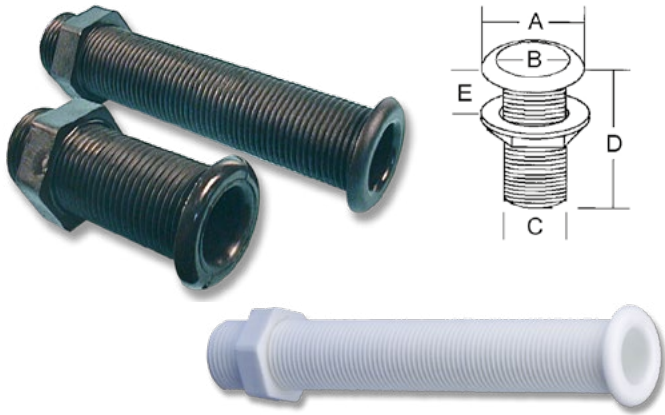

Scarico a mare completo di tappo

Seacock with cap

Fabbricato in nylon. Completo di tappo a vite e valvola di non ritorno. Manufactured in nylon. With screwed-cap and non-return valve.

| Articolo - Item | €/pc. | A mm. | B mm. | C mm. | D mm. |
|-----------------|-------|-------|-------|-------|-------|
| N 28 35 143 | | 50 | 34 | 39 | 140 |

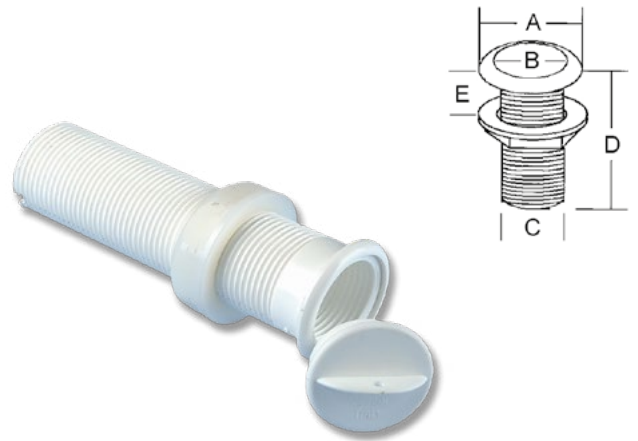

Scarico a mare con membrana

Seacock with membrane

Fabbricato in nylon bianco e membrana in gomma. Manufactured in white nylon. Rubber membrane.

| Articolo - Item | €/pc. | A mm. | B mm. | C mm. | D mm. | E mm. | F mm. |
|-----------------|-------|-------|-------|-------|-------|-------|-------|
| P 02 42 115 | | 67 | 110 | 50 | 46 | 65 | 34 |



Scarico a mare gigante a norme CE

CE seacock

Fabbricato in nylon bianco, autosvuotante con valvola di non ritorno per paratie con spessore da 65 a 215 mm. Telescopico. Montaggio a pressione. Manufactured in white nylon. With screwed-cap and non-return valve. Suitable for bulkheads 65-215 mm. Telescopic model. Pressure mounting.

| Articolo - Item | €/pc. | Colore Colour | Ø interno-inner mm. | Ø esterno-outer mm. |
|-----------------|-------|---------------|---------------------|---------------------|
| N 28 80 004 | | Bianco-White | 45 | 55 |



Scarichi a mare con ghiera (ombrinale) in plastica

Seacocks with plastic scupper

| Articolo - Item Bianco-White | €/pc. | €/Box | Articolo - Item Nero-Black | €/pc. | €/Box | Ø inch. | Ø A mm. | Ø B mm. | C mm. | Ø D mm. | E mm. | F mm. |
|------------------------------|-------|-------|----------------------------|-------|-------|---------|---------|---------|-------|---------|-------|-------|
| N 01 22 015 | | | N 01 22 080 | | | 1/2" | 44 | 75 | 23 | 15 | 40 | 15 |
| N 01 26 018 | | | N 01 26 080 | | | 3/4" | 50 | 80 | 25 | 18 | 40 | 18 |
| N 01 32 025 | | | N 01 32 080 | | | 1" | 62 | 95 | 32 | 25 | 45 | 25 |
| N 01 41 030 | | | N 01 41 080 | | | 1 1/4" | 74 | 103 | 45 | 32 | 50 | 35 |
| N 01 47 037 | | | N 01 47 080 | | | 1 1/2" | 76 | 104 | 45 | 40 | 55 | 35 |

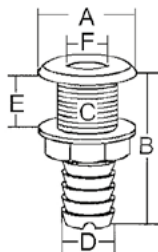

Tappo scarico acqua

In ottone cromato con tappo in nylon e dispositivo di sicurezza che rende impermeabile il tappo. Esterno 52x35 mm. Interasse fori 38 mm.

Drain plug

Manufactured in chromed brass with nylon cap. Safety lock included. Outer size 52x35 mm. Hole spacing 38 mm.

| Articolo - Item | €/pc. | Foro-Hole Ø mm. | Incasso Recess Ø mm. |
|-----------------|-------|--------------------|-------------------------|
| P 02 23 018 | | 18 | 23 |



Ombriale rotondo con tappo a vite e arresto

Fabbricato in nylon nero. Per scarico acqua dai pozzetti. Interasse fori 41 mm. Passaggio 17 mm.

Drain plug with screwed cap

Manufactured in black nylon. Hole spacing 41 mm.

| Articolo - Item | €/pc. | €/Box | esterno outer mm. | Incasso Ø mm. |
|-----------------|-------|-------|----------------------|------------------|
| P 02 25 050 | | | 52x29 | 27 |



Tappo scarico acqua

In nylon nero, con sicurezza per il tappo. Interasse 39 mm.

Drain plug

Manufactured in black nylon. Safety lock included. Hole spacing 39 mm.

| Articolo-Item | €/pc. | €/Box | esterno outer mm. | Incasso Ø mm. | Hole mm. |
|---------------|-------|-------|----------------------|------------------|-------------|
| P 02 18 027 | | | 52x35 | 24 | 17 |



Tappo scarico acqua

In nylon bianco, con sicurezza per il tappo. Interasse 40 mm.

Drain plug

Manufactured in white nylon. Safety lock included. Hole spacing 40 mm.

| Articolo - Item | €/pc. | Ø esterno outer mm. | Foro-Hole Ø mm. | Passaggio mm. |
|-----------------|-------|------------------------|--------------------|------------------|
| P 02 19 637 | | 50 | 26 | 17 |



Ombriale rotondo con tappo a vite

Fabbricato in nylon bianco. Per scarico acqua dai pozzetti.

Drain plug with screwed cap

Manufactured in white nylon.

| Articolo - Item | €/pc. | Ø esterno outer mm. | Foro-Hole Ø mm. | kg. |
|-----------------|-------|------------------------|--------------------|-------|
| P 02 19 050 | | 19 | 16 | 0,050 |



SUCCHIAROLE | SUCTION STRAINERS

Succhiarola

In ottone con filtro in rete 97x55 mm. Portagomma Ø 16 mm.

Suction strainer

Manufactured in brass with filter 97x55 mm. Hose adapter Ø 16 mm.

| Articolo - Item | €/pc. |
|-----------------|-------|
| P 02 55 097 | |

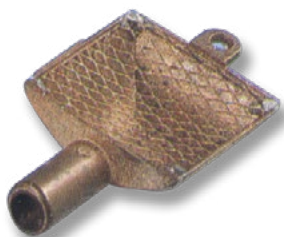

Ombriinale

Fabbricato in acciaio inox Aisi 316 microfuso e lucidato a specchio.

Scupper

Manufactured in Aisi 316 mirror polished precision-cast stainless steel.

| Articolo - Item | €/pc. | Filetto Threading | A mm. | C mm. | kg. |
|-----------------|-------|-------------------|-------|-------|-------|
| N 29 73 050 | | 2" | 80 | 59,5 | 0,880 |

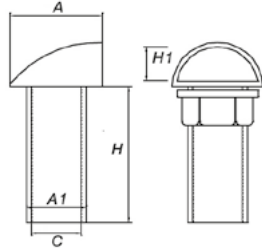

Ombriali

Realizzati in nylon 66 + 30% fibra di vetro. Scarico in acciaio inox Aisi 316 fuso a cera persa.

Scuppers

Made of Nylon 66 + 30% fibreglass. Drain head in Aisi 316 stainless steel.

| Articolo - Item | €/pc. | A mm. | B mm. | C mm. | D mm. | E mm. |
|-----------------|-------|-------|-------|-------|-------|-------|
| P 02 03 254 | | 25 | 96 | 33 | 53 | 46 |
| P 02 03 256 | | 28 | 96 | 33 | 53 | 46 |
| P 02 03 258 | | 32 | 111 | 41 | 65 | 48 |
| P 02 03 260 | | 38 | 111 | 41 | 65 | 52 |

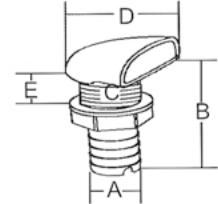

Scarico a mare

Per tubi da 5/8".

Seacock

For 5/8" pipes.

| Articolo - Item | €/pc. | A mm. | B mm. | C mm. | D mm. | E mm. | kg. |
|-----------------|-------|-------|-------|-------|-------|-------|-------|
| N 29 58 074 | | 17 | 60 | 19 | 32 | 36 | 0,020 |

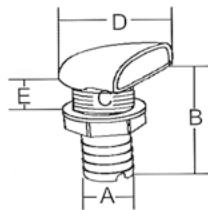

Scarico a mare e ombriali

In plastica, completo di valvola di non ritorno.

Seacock & scuppers

In plastic, with no-return valve.

| Articolo - Item | €/pc. | Mod. | Filetto | | | | |
|-----------------|-------|--------|-----------|-------|-------|-------|-------|
| | | | Threading | Ø mm. | A mm. | B mm. | C mm. |
| P 02 46 035 | | 1" 1/2 | 47 | 38 | 30 | 93 | 82 |

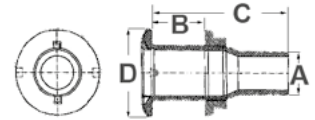

CUFFIE COPRISCARICO | SHELL VENTS

Cuffie copriscarico

Shell vents

| Articolo - Item | pcs. | €/pc. | €/ | Materiale-Material | A mm. | B mm. | C mm. |
|-----------------|------|-------|----|--|-------|-------|-------|
| Z 22 40 045 | 10 | | | Acciaio inox Aisi 316-Aisi 316 Stainless steel | 60 | 57 | 12 |
| Z 22 54 057 | 6 | | | Acciaio inox Aisi 316-Aisi 316 Stainless steel | 64 | 66 | 16 |
| Z 22 87 093 | 6 | | | Acciaio inox Aisi 316-Aisi 316 Stainless steel | 96 | 87 | 25 |
| N 29 50 074 | 10 | | | Nylon bianco-White nylon | 55 | 49 | 12 |
| N 29 50 081 | 10 | | | Nylon nero-Black nylon | 55 | 49 | 12 |

made by



N2950074-081



Z2240045



Z2254057



Z2287093

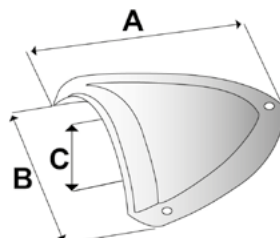

TAPPI AD ESPANSIONE | DRAIN PLUGS

Tappo ad espansione

Fabbricata in ottone.
Passaggio totale F/F.

| Articolo - Item | €/pc. | Per foro-For hole | kg. |
|-----------------|-------|-------------------|-------|
| N 28 01 582 | | 1" | 0,030 |



Drain plug

Made in brass
Female/Female.

Tappi galleggianti ad espansione a camme

Per scaricare acqua da pozzetti, casse del pesce e casse delle esche. Pressione regolabile a rotazione. Corpo in neoprene e carcassa in nylon.

Cam expansion floating drain plug

Suitable to drain water from cockpits, fish baskets, fish bait cases. Rotating adjustable pressure. Neoprene body and nylon frame.

| Articolo - Item | €/kit da 3 tappi | Ø mm. |
|-----------------|------------------|------------------------------|
| N 28 34 680 | | 12 (1/2")+16 (5/8")+19(3/4") |



Tappi ad espansione in acciaio inox Aisi 316

| Articolo - Item | €/pc. | Per foro-For hole Ø mm. | kg. |
|-----------------|-------|-------------------------|-------|
| N 28 13 017 | | da-from 13 a-to 17 | 0,050 |
| N 28 22 026 | | da-from 22 a-to 26 | 0,100 |
| N 28 29 033 | | da-from 29 a-to 33 | 0,150 |



Aisi 316 stainless steel drain plugs

Tappo ad espansione per scarico acqua

Fabbricato in ottone con gommino in neoprene.

Drain plug

Manufactured in brass, with rubber.

| Articolo - Item | €/pc. | Per foro-For hole Ø mm. | kg. |
|-----------------|-------|-------------------------|-------|
| N 28 23 092 | | 23 | 0,090 |



Tappo ad espansione per scarico acqua

Fabbricato in ottone con gommino in neoprene.

Drain plug

Manufactured in brass, with rubber.

| Articolo - Item | €/pc. | Per foro-For hole Ø mm. | kg. |
|-----------------|-------|-------------------------|-------|
| N 28 23 090 | | 23 | 0,090 |



Tappo ad espansione in nylon per scarico acqua

Con tappo provvisto di gomma.

Drain plug

Manufactured in nylon w/rubber.

| Articolo - Item | €/pc. | Mod. | Foro-Hole Ø mm. |
|-----------------|-------|---------------|-----------------|
| N 28 30 080 | | Piccolo-Small | 23 |
| Z 14 06 033 | | Medio-Midi | 33 |
| N 28 42 080 | | Grande-Big | 42 |



Tappo ad espansione per scarico acqua

Fabbricato in ottone e provvisto di gomma.

Drain plug

Manufactured in brass with rubber.

| Articolo - Item | €/pc. | Foro-Hole Ø mm. | kg. |
|-----------------|-------|-----------------|-------|
| N 28 23 082 | | 23 | 0,085 |



Tappo ad espansione per scarico acqua

Fabbricato in ottone e provvisto di gomma.

Drain plug

Manufactured in brass with rubber.

| Articolo - Item | €/pc. | Foro-Hole Ø mm. |
|-----------------|-------|-----------------|
| N 28 06 457 | | 50 |



Raccordi rapidi Ø 12 mm.

Montaggio rapido a scatto con una semplice pressione del tubo.
Realizzati in plastica atossica in conformità alle normative vigenti (D.M. 21/03 1973 e successive modifiche).
Riutilizzabili.
Tubo in polietilene semirigido.
(CLIPS DA ACQUISTARE A PARTE)

Quick fittings Ø 12 mm.

Quick fitting by a simple pressure of the pipe.
Manufactured in non-toxic plastic according to Rules (D.M. 21/03 1973).
Can be re-used.
Pipe manufactured in semirigid polyethylene.
(CLIPS TO BE ORDERED SEPARATELY)

Raccordo a gomito Elbow fitting 12 mm.

Articolo - Item €/pc. €/Box
N 01 12 020



Raccordo dritto Straight fitting 12 mm.

Articolo - Item €/pc. €/Box
N 01 12 021



Raccordo a «T» «T» Hose connector 12 mm.

Articolo - Item €/pc. €/Box
N 01 12 005



Raccordo a «Y» «Y» Hose connector 12 mm.

Articolo - Item €/pc. €/Box
N 01 12 023



Terminale 12 mm. Straight fitting 12 mm. Femmina 3/8" Female 3/8"

Articolo - Item €/pc. €/Box
N 01 12 006



Codolo 12 mm. Hose shank 12 mm. Maschio 1/2" Male 1/2" Male

Articolo - Item €/pc. €/Box
N 01 12 004



Codolo 12 mm. Hose shank 12 mm. Maschio 3/8" Male 3/8" Male

Articolo - Item €/pc. €/Box
N 01 12 008



Terminale 12 mm. Straight fitting 12 mm. Maschio 3/8" Male 3/8"

Articolo - Item €/pc. €/Box
N 01 12 386



Gomito con codolo Elbow fitting 12 mm.

Articolo - Item €/pc. €/Box
N 01 12 024



Terminale 12 mm. Straight fitting 12 mm. Femmina 1/2" Female 1/2" F

Articolo - Item €/pc. €/Box
N 01 12 104



Terminale 12 mm. Straight fitting 12 mm. Maschio 1/2" Male 1/2" M

Articolo - Item €/pc. €/Box
N 01 12 204



Clip blocca pinza Clamp

Articolo - Item €/Box
N 01 38 000C



Tagliatubi Pipe cutting device

Articolo - Item €/pc.
N 01 38 012



Raccordo a gomito Elbow fitting 12 mm. Fem. 1/2" Female 1/2" F

Articolo - Item €/pc. €/Box
N 01 12 040



IDEALE PER POMPE IDEAL FOR PUMPS



Raccordo dritto Straight tap 12 mm.

Articolo - Item €/pc. €/Box Mod.
N 01 12 212 -
N 01 12 213 Asta-Rod 230 mm.



CON RUBINETTO WITH TAP



Tubo rosso 12 mm. Red pipe 12 mm. in rotoli da 100 mt. reel of 100 mt.

Articolo - Item €/ mt.
N 01 82 116 100



Tubo blu 12 mm. Blue pipe 12 mm. in rotoli da 100 mt. reel of 100 mt.

Articolo - Item €/ mt.
N 01 75 116 100



I RACCORDI SONO PRIVI DI CLIPS Art. N0138000C

FITTINGS SUPPLIED WITHOUT CLIPS Art. N0138000C

Boiler «ATI»

Fabbricato con caldaia in acciaio inox Aisi 316 rivestimento esterno inox Aisi 316 lucidato a specchio e scambiatore di calore inox.
 Funzionamento con scambiatore di calore o resistenza elettrica di 1200W a 230V.
 Isolamento spinto tra serbatoio e carcassa in poliuretano espanso.

Boiler «ATI»

Manufactured with Aisi316 stainless steel boiler, external coating in mirror polished Aisi316 stainless steel and stainless steel heat exchanger.
 Operation with heat exchanger or electric resistance of 1200W to 230V. supercharged insulation between tank and frame in foam polyurethane.

| Articolo - Item | €/pc. | Lt. | Lunghezza totale-Full length mm. | Interasse staffe-Centre distance mm. |
|-----------------|-------|-----|----------------------------------|--------------------------------------|
| N 01 12 120 | | 12 | 387 | 175 |
| N 01 22 120 | | 22 | 485 | 335 |
| N 01 30 120 | | 30 | 619 | 470 |



N0112120



N0122120-N0130120

FASCETTE PER TUBI | CLAMPS

Fascette stringitubo in acciaio inox

Fabbricato con caldaia in acciaio inox Aisi 316 rivestimento esterno inox Aisi 316 lucidato a specchio e scambiatore di calore inox.
 Funzionamento con scambiatore di calore o resistenza elettrica di 1200W a 230V.
 Isolamento spinto tra serbatoio e carcassa in poliuretano espanso.

Clamps in stainless steel

Manufactured with Aisi316 stainless steel boiler, external coating in mirror polished Aisi316 stainless steel and stainless steel heat exchanger.
 Operation with heat exchanger or electric resistance of 1200W to 230V. supercharged insulation between tank and frame in foam polyurethane.

| Articolo - Item | €/pc. | €/Box | Ø mm. min. | Ø mm. max. | Banda mm. | kg. |
|-----------------|-------|-------|------------|------------|-----------|-------|
| E 60 00 020 | | | 12 | 22 | 12 | 0,120 |
| E 60 00 032 | | | 16 | 24 | 12 | 0,130 |
| E 60 00 051 | | | 30 | 45 | 12 | 0,170 |
| E 60 00 070 | | | 32 | 50 | 12 | 0,180 |
| E 60 00 089 | | | 40 | 60 | 12 | 0,200 |
| E 60 00 108 | | | 50 | 70 | 12 | 0,210 |
| E 60 00 127 | | | 60 | 80 | 12 | 0,220 |
| E 60 00 140 | | | 70 | 90 | 12 | 0,230 |
| E 60 00 156 | | | 90 | 110 | 12 | 0,250 |
| E 60 00 184 | | | 100 | 120 | 12 | 0,260 |
| E 60 00 227 | | | 110 | 130 | 12 | 0,330 |

AISI 316



Fascette stringitubo «Mini» in acciaio inox

Fabbricato con caldaia in acciaio inox Aisi 316 rivestimento esterno inox Aisi 316 lucidato a specchio e scambiatore di calore inox.
 Funzionamento con scambiatore di calore o resistenza elettrica di 1200W a 230V.
 Isolamento spinto tra serbatoio e carcassa in poliuretano espanso.

Clamp in stainless steel Aisi 304 «Mini»

Manufactured with Aisi316 stainless steel boiler, external coating in mirror polished Aisi316 stainless steel and stainless steel heat exchanger.
 Operation with heat exchanger or electric resistance of 1200W to 230V. supercharged insulation between tank and frame in foam polyurethane.

| Articolo - Item | €/pc. | €/Box | Ø mm. min. | Ø mm. max. | kg. |
|-----------------|-------|-------|------------|------------|-------|
| E 60 06 007 | | | 7 | 9 | 0,400 |
| E 60 06 009 | | | 9 | 11 | 0,500 |
| E 60 06 011 | | | 11 | 13 | 0,600 |

AISI 316



VISITA IL NOSTRO
 NUOVO WEBSITE



WWW.TREM.NET



Tubo retinato flessibile atossico

Fabbricato in PVC plastificato con rinforzo in filato di poliestere. Colore trasparente. Temperatura d'impiego -10°C +60°C. Resistente agli agenti atmosferici e a gran parte dei prodotti chimici. Uso: passaggio di acqua, aria compressa e liquidi. Pressione di esercizio 10 bar. Costruito secondo norme CE.

Non-toxic reinforced PVC hose

Manufactured in PVC with polyester yarn reinforcement. Transparent colour. Working temperature -10°C +60°C. Resistant to atmospheric agents and to most chemicals. Suitable for water distribution or for bilge pumps. Working pressure 10 bar. In compliance with CE rules.

| Articolo - Item | €/mt. | € | Ø mm. | mt. |
|-----------------|-------|---|-------|-----|
| N 18 10 116 | | | 10x16 | 100 |
| N 18 12 118 | | | 12x18 | 100 |
| N 18 15 521 | | | 15x21 | 100 |
| N 18 19 526 | | | 19x26 | 50 |
| N 18 25 533 | | | 25x33 | 50 |



Tubo spirolato atossico

Fabbricato in PVC plastificato trasparente con spirale di rinforzo in acciaio incorporata. Temperatura d'impiego -10°C +60°C. Molto flessibile, robusto, resistente all'abrasione. Uso: passaggio di acqua, aspirazione e mandata liquidi. Pressione di esercizio 4 bar. Costruito secondo norme CE.

Non-toxic Hose

Manufactured in transparent PVC with built-in steel reinforcement spiral. Working temperature -10°C +60°C. Very strong and flexible, abrasion resistant. Suitable for suction and liquids pumping. Working pressure 4 bar. In compliance with CE rules.

| Articolo - Item | €/mt. | € | Ø mm. | mt. |
|-----------------|-------|---|-------|-----|
| N 18 12 318 | | | 12x18 | 30 |
| N 18 16 622 | | | 16x22 | 30 |
| N 18 18 325 | | | 18x25 | 30 |
| N 18 20 627 | | | 20x27 | 30 |
| N 18 25 634 | | | 25x34 | 30 |
| N 18 30 640 | | | 30x40 | 30 |
| N 18 35 646 | | | 35x46 | 30 |
| N 18 38 648 | | | 38x48 | 30 |
| N 18 40 353 | | | 40x53 | 30 |
| N 18 45 355 | | | 45x55 | 30 |
| N 18 50 360 | | | 50x60 | 30 |
| N 18 60 375 | | | 60x75 | 30 |
| N 18 70 386 | | | 70x86 | 30 |
| N 18 80 297 | | | 80x97 | 20 |



Tubo «Sanitar»

Fabbricato in PVC bianco con spirale in acciaio, antiodore per servizi sanitari, scarico pompe e lavelli.

Hose «Sanitar»

Manufactured in white anti-odour PVC with built-in steel reinforcement spiral. Suitable for for WC, pumps and sinks.

| Articolo - Item | €/mt. | € | Ø interno-inner mm. | mt. |
|-----------------|-------|---|---------------------|-----|
| N 18 20 016 | | | 20 | 30 |
| N 18 25 016 | | | 25 | 30 |
| N 18 38 016 | | | 38 | 30 |
| N 18 40 016 | | | 40 | 30 |



Tubo sanitari in PVC nero

Flessibile in Pvc nero antitraspirazione odori armato con spirale in acciaio. Maggiore protezione agli UV. Ideale per non creare vegetazione e nascondere il passaggio dei rifiuti. A differenza del bianco, il nero non si sporca.

Sanitar water pipe in black PVC

Manufactured in high quality anti-odour black PVC with internal steel spiral. UV protection. Suitable for avoiding any making of vegetation and hiding the passage of waste.

| Articolo - Item | €/mt. | € | Ø interno-inner mm. | mt. |
|-----------------|-------|---|---------------------|-----|
| N 18 20 030 | | | 20 | 30 |
| N 18 25 030 | | | 25 | 30 |
| N 18 40 030 | | | 40 | 30 |



Gli "unici" serbatoi di produzione italiana che hanno superato i test internazionali!

The "only" Italian production tanks that have passed the international tests!

Big Joe



SERBATOI CARBURANTE CONFORMI USA | FUEL TANKS «BIG JOE»

Serbatoio carburante «Big-Joe»

Tanica costruita in eltex, certificata ISO 13591 e conforme al decreto ministeriale. Completa di riserva. Riempimento al 90% e tappo con sfiato di sicurezza a vite. Questo modello è provvisto di sistema autopescante con filtro.

Portable fuel tank «Big-Joe»

Tank made of eltex, 90% filling with security plug. This model is provided with float and filter. 90% filling and cap with safety screw vent. This model is equipped with a self-priming filter system.

| Articolo - Item | €/pc. | Mod. | Lt. | Riserva-Reserve Lt. | A cm. | B cm. | C cm. | pcs. |
|-----------------|-------|--|-----|---------------------|-------|-------|-------|------|
| N 01 12 003 | - | - | 12 | 1,5 | 26 | 46 | 18 | 8 |
| N 01 22 003 | - | - | 22 | 4 | 32 | 54 | 20,9 | 6 |
| N 01 29 664 | - | - | 30 | 4 | 36 | 50 | 24,8 | 6 |
| N 01 22 001 | - | con indicatore di livello-with level indicator | 22 | 4 | 32 | 54 | 20,9 | 6 |

madeby 

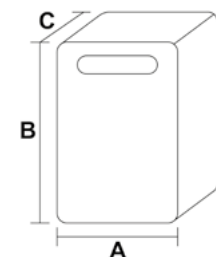

ABYC U.S.A. CERTIFIED

CERTIFICATI SECONDO LO STANDARD INTERNAZIONALE «ISO 13591» CONFORME «USA ABYC H-25» D.M. N. 514 DEL 5/11/87

UNDER INTERNATIONAL STANDARD «ISO 13591» ACCORDING TO «USA ABYC H-25» D.M. N. 514 OF 5/11/87

COMPLETO DI



Art. N0144000 (pag. 455)

SUGGESTED ITEM



IND. GALLEGG. Art. N0147550 (pag. 224) Art. D1000042 (pag. 116) Art. N0100180 (pag. 224)



N0112003-N0122003-N0129664



N0122001

Tappo con indicatore di livello

Indicatore per serbatoi «Big Joe».

Plug with level indicator

Suitable for «Big Joe» fuel tanks.

| Articolo - Item | €/pc. | H mm. | Ideale per-Suitable for |
|-----------------|-------|-------|-------------------------|
| N 01 44 160 | - | 160 | N0112003 |
| N 01 44 180 | - | 180 | N0122003 |
| N 01 44 220 | - | 220 | N0129664 |

madeby 



Tappo con sfiato di sicurezza per serbatoio carburante

Completo di sfiato di sicurezza a vite. Filetto unificato per le taniche più diffuse sul mercato.

Plug for fuel tank «Big Joe»

Complete with safety air blow.

| Articolo - Item | €/pc. | Filetto-Threading Ø mm. |
|-----------------|-------|-------------------------|
| N 01 44 000 | - | 44 |

madeby 



TANICHE BENZINA | FUEL TANKS

Taniche carburante omologate CE fuel tanks

Fabbricate in plastica. Complete di bocchettone flessibile e sfiato di sicurezza. Manufactured in plastic. With flexible spout and security plug.

| Articolo - Item | €/pc. | Lt. | A cm. | B cm. | C cm. | pcs. | kg. |
|-----------------|-------|-----|-------|-------|-------|------|-----|
| N 01 05 082 | | 5 | | | | 10 | |
| N 01 10 082 | | 10 | 28 | 33 | 15 | 6 | |
| N 01 22 082 | | 20 | 32 | 42 | 20 | 4 | |



COMPLETO DI-COMLETE WITH

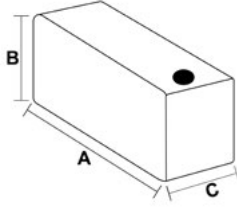

Taniche carburante con indicatore di livello

Fabbricate in plastica. Complete di bocchettone flessibile. Colore rosso. Manufactured in plastic. With flexible spout. Red colour.

| Articolo - Item | €/pc. | Lt. | A cm. | B cm. | C cm. | pcs. | kg. |
|-----------------|-------|-----|-------|-------|-------|------|-----|
| N 01 05 024 | | 5 | 26 | 24 | 16 | 6 | |
| N 01 10 024 | | 10 | 26 | 38 | 16 | 6 | |



COMPLETO DI-COMLETE WITH

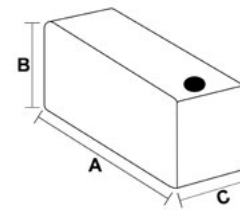

Taniche in plastica con sistema brevettato di rabbocco benzina Plastic auto shut off fuel cans

EAP & AS/NZS 2906:2001 Standards. EAP & AS/NZS 2906:2001 Standards.

| Articolo - Item | €/pc. | Lt. | A cm. | B cm. | C cm. | kg. |
|-----------------|-------|-----|-------|-------|-------|-------|
| N 01 05 182 | | 5 | 26 | 27,5 | 13 | 0,800 |
| N 01 10 182 | | 10 | 29 | 34,6 | 16 | 1,300 |
| N 01 20 182 | | 20 | 33 | 47,6 | 19 | 1,800 |

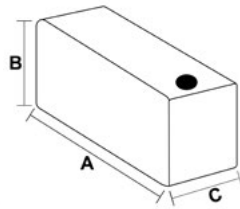

Taniche carburante

Realizzate in polietilene antitrottura. Dotate di particolare sistema di sfiato nel tappo. Manufactured in unbreakable Polyethylene. Equipped with safety air blow system.

Fuel tanks

Manufactured in unbreakable Polyethylene. Equipped with safety air blow system.

| Articolo - Item | €/pc. | Lt. | A cm. | B cm. | C cm. | Mod. |
|-----------------|-------|-----|-------|-------|-------|--------|
| N 01 07 081 | | 5 | 22 | 24 | 16 | Fuel |
| N 01 07 079 | | 10 | 29 | 30 | 19 | Fuel |
| N 01 06 402 | | 20 | 30 | 39 | 25 | Fuel |
| N 01 07 539 | | 25 | 36 | 43 | 25 | Fuel |
| N 01 03 711 | | 20 | 33 | 47 | 19 | Diesel |



SUGGESTED ITEM

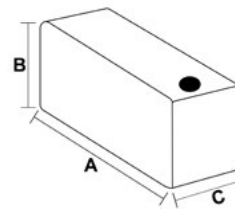

N0107081-079-06402-07359



N0103711

TANICHE BENZINA | FUEL TANKS

Tappo per taniche

Plug for fuel tanks

| Articolo - Item | €/pc. | Filetto-Threading Ø mm. |
|-----------------|-------|-------------------------|
| N 01 00 035 | | 37,5 |
| N 01 00 036 | | 36,5 |



Travasatore per taniche

Funnel for fuel tanks

| Articolo - Item | €/pc. | Lunghezza-Length mm. |
|-----------------|-------|----------------------|
| N 01 00 027 | | 270 |
| N 01 00 030 | | 300 |



Imbuto per taniche

Funnel for fuel tanks

| Articolo - Item | €/pc. |
|-----------------|-------|
| N 01 03 629 | |



Pistola carburante

Adatta a tutti i modelli di serbatoio in plastica in commercio. Non è necessario utilizzare l'imbuto. Include un sistema di sicurezza per bambini.

Refuelling nozzle

Suitable for all fuel tanks on the market. Funnel not necessary. Children safety device included.

| Articolo - Item | €/pc. | Mod. | kg. |
|-----------------|-------|----------------|-------|
| N 01 06 799 | | Pistola-Nozzle | 0,860 |



SERBATOI CARBURANTE CE | CE FUEL TANKS

Serbatoi carburante

Certificati CE. Completi di tappo e pescanti.

Fuel tanks

In compliance with CE rules. Supplied with cap and float.

| Articolo - Item | €/pc. | Lt. | A cm. | B cm. | C cm. |
|-----------------|-------|-----|-------|-------|-------|
| N 01 22 030 | | 35 | 22 | 50 | 35 |
| N 01 22 045 | | 42 | 22 | 65 | 35 |
| N 01 22 055 | | 52 | 22 | 80 | 35 |
| N 01 22 070 | | 76 | 22 | 105 | 35 |
| N 01 30 045 | | 49 | 30 | 50 | 35 |
| N 01 30 060 | | 60 | 30 | 65 | 35 |
| N 01 30 075 | | 81 | 30 | 80 | 35 |
| N 01 30 100 | | 106 | 30 | 105 | 35 |



SUGGESTED ITEM

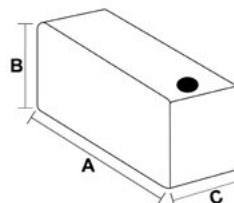
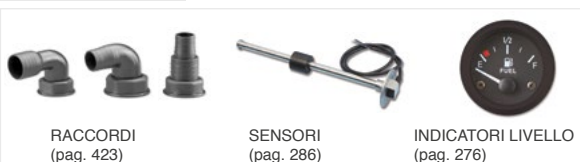

TRAVASO OLIO E CARBURANTE | OIL AND FUEL TRANSFER

Pompa con serbatoio per estrazione olio-acqua**Pump with tank to remove oil-water**

| Articolo - Item | €/pc. | Mod. | cl. | kg. |
|-----------------|-------|------------------|-----|-------|
| P 02 18 547 | | - | 4,5 | 2,250 |
| P 02 18 548 | | (a sfera-sphere) | 6 | 1,650 |



P0218547



P0218548

Pompa cambio olio motore**Gear lube pump**

- Per uso con bottiglie in plastica da 32oz. (946ml).
- E' adatto ad ogni motore fuoribordo o piede poppiere con raccordo a vite 3/8" - 16.
- Include adattatore Yamaha.

- For use with 32oz. (946ml) plastic bottles.
- Fits any outboard or sterndrive with a 3/8" - 16 drain screw.
- Includes Yamaha adaptor.

| Articolo - Item | €/pc. | kg. |
|-----------------|-------|-------|
| P 02 24 543 | | 0,110 |

**Kit cambio olio portatile 6 litri****Portable oil change kit**

Composto da:

- Tubo nero Ø 6,5mm. x 1200mm.
- Tubo nero Ø 8,3mm. x 1200mm.
- Tubo trasparente Ø 15,8mm. x 2440mm.

Kit complete with:

- Black hose Ø 6,5mm. x 1200mm.
- Black hose Ø 8,3mm. x 1200mm.
- Hose Ø 15,8mm. x 2440mm.

| Articolo - Item | €/pc. | kg. |
|-----------------|-------|-------|
| P 02 24 540 | | 1,170 |

**Pompa per estrazione olio-benzina-acqua****Pump to remove oil-fuel-water**

Fabbricata in ottone.

Manufactured in brass.

| Articolo - Item | €/pc. | cl. | kg. |
|-----------------|-------|-----|-------|
| P 02 80 000 | | 15 | 0,200 |

**Pompa elettrica per olio motore****Electric gear pump**

Autoadescente. Volts 24, Amp.6

Elementi per l'autoadesamento all'interno.

Tubo dia: 5/8" (16mm). Girante in rame. Raccordi da 3/8".

Self priming.

Pumping elements inside.

Hose dia: 5/8" (16mm)

| Articolo - Item | €/pc. | GPM/LPM | mm. | kg. |
|-----------------|-------|-----------------------------------|-----------------|-------|
| N 01 24 032 | | 3,2 / 12 | 215 x 135 x 110 | 2,480 |
| N 01 01 038 | | Raccordo - Connection 3/8" x 1/2" | | |

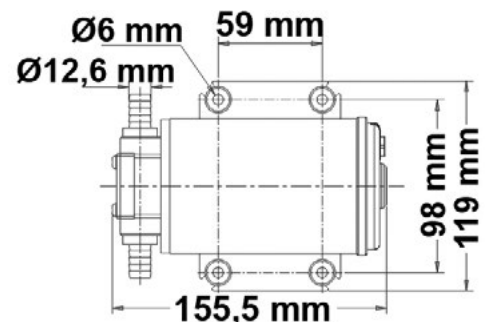
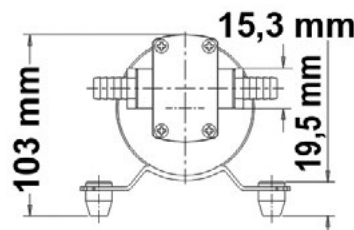

Superpump

Il migliore e l'"originale", efficace strumento per il trasferimento di qualsiasi tipo di liquido: gasolio, olio, benzina, acqua, detersivi, ecc. Permette di svuotare completamente i contenitori senza alcuno sforzo e senza dover succhiare per estrarre.

Superpump

The best and the "original", effective tool for transferring any type of liquid: diesel, oil, gasoline, water, detergents, etc. It allows to completely empty the containers without any effort and without any need to suck to extract.

| Articolo - Item | €/pc. | Lt. | Per tubo Ø interno-For hose inner Ø mm. |
|-----------------|-------|---------|---|
| P 02 00 001 | | 19/min. | 13 |
| P 02 19 001 | | 30/min. | 19 |



Pompa manuale travaso liquidi

Con questo semplice e ingegnoso attrezzo si possono travasare tutti i tipi di liquido (acqua, gasolio, benzina ecc.) da un contenitore ad un altro evitando di sporcare e senza alcuna fatica. E' sufficiente inserire la pompa nel contenitore con il liquido da travasare e la parte finale del tubo in quello in cui dovrà essere trasferito. Avendo cura di porre il secondo contenitore ad un livello leggermente più basso del primo sarà sufficiente agitare la pompa nel liquido per far salire lo stesso fino al collo d'oca del tubo, punto in cui attiverà il travaso per "caduta" nel recipiente che lo dovrà accogliere. Per bloccare il flusso sarà sufficiente togliere la pompa dal tubo. Realizzato in rame e completo di tubo.

Manual siphon pump for liquid transfer

With this simple and ingenious tool you can easily decant all liquids (water, diesel, petrol, etc.) from a container to another without dirtying. Place the pump into the container with the liquid and the end of its hose into the transfer container, taking care to place the second container at a slightly lower level. Stir the pump in the liquid to let it rise up to the pump head so that the liquid will pour into the other container. Disconnect the pump from the hose to stop the flow. Made of copper and supplied with hose.

| Articolo - Item | €/pc. | Ø interno tubo-Hose inner Ø mm. | Ø " | Portata-Flow Lt/min. | Lunghezza tubo-Hose length mt. |
|-----------------|-------|---------------------------------|------|----------------------|--------------------------------|
| N 01 25 018 | | 13 | 1/2" | 18 | 1,75 |
| N 01 16 015 | | 19 | 3/4" | 30 | 2,00 |



Imbuto

Fabbricato in plastica.
Ø 145 mm.
Con tubo flessibile e filtro.

Funnel

Manufactured in plastic.
Ø 145 mm.
With flexible hose and filter.

| Articolo - Item | €/pc. |
|-----------------|-------|
| N 01 02 415 | |



Imbuto, filtro, prolunga

| Articolo - Item | €/pc. | Mod. |
|-----------------|-------|--|
| P 00 00 100 | | Imbuto con filtro e bordo paraspruzzo Ø 180 mm. H 240 mm. |
| P 00 00 050 | | Prolunga-Extension 350 mm. |



Funnel, filter, extension

Caraffina graduata

Per olio miscela.
Capacità 200 gr. di olio.

Graduated pitcher

Suitable for mix.
Capacity 200 gr. of oil.

| Articolo - Item | €/pc. | Ø mm. | H mm. |
|-----------------|-------|-------|-------|
| N 01 06 012 | | 58 | 120 |



TUBAZIONI E POMPETTE CARBURANTE | PIPES & FUEL PRIMER PUMPS

Pompetta di aspirazione carburante

Completa di valvole e di portagomma.

Fuel primer bulb

Complete with valves and hose adapter.

| Articolo - Item | €/pc. | Ø mm. | Lunghezza Length mm. | ↕ | Per tubi carburante For fuel pipes Ø mm. |
|-----------------|-------|-------|----------------------|------|--|
| N 01 34 095 | | 45 | 120 | 3/8" | 10 |



Pompetta di aspirazione carburante alta capacità

Realizzata in PVC, a grande capacità.

High capacity fuel primer bulb

Manufactured in PVC.

| Articolo - Item | €/pc. | Ø mm. | Lunghezza Length mm. | ↕ | Per tubi carburante For fuel pipes Ø mm. |
|-----------------|-------|-------|----------------------|-------|--|
| N 01 14 672 | | 50 | 145 | 3/8" | 10 |
| N 01 10 672 | | 50 | 145 | 5/16" | 8 |



Pompetta di aspirazione carburante

Realizzata in termopolimero speciale. Provvista di raccordi amovibili Ø 6-8-10 mm.

Fuel primer bulb

Manufactured in special thermopolymer. With removable fittings Ø 6-8-10 mm.

| Articolo - Item | €/pc. | Ø mm. | Lunghezza Length mm. | ↕ | Per tubi carburante For fuel pipes Ø mm. |
|-----------------|-------|-------|----------------------|-------|--|
| N 01 08 494 | | 4,75 | 145 | 5/16" | 8 |



SIFONI E SCARICHI | EXHAUST MUFFLERS

Marmitta per motori raffreddati ad acqua

Fabbricata in plastica.

Exhaust muffler for water-cooled engines

Manufactured in plastic

| Articolo - Item | €/pc. | Ø Attacco-Connection mm. | Lt. |
|-----------------|-------|--------------------------|-----|
| N 01 06 115 | | 110-115 | 6 |

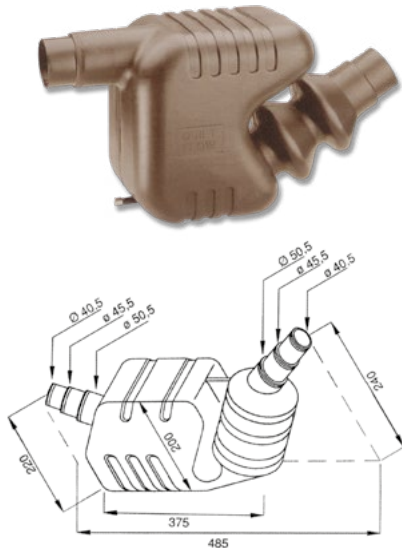

Marmitta di scarico

Fabbricata in neoprene.

Exhaust muffler

Manufactured in Neoprene.

| Articolo - Item | €/pc. | Ø interno/esterno mm. inner/outer Ø mm. | Lunghezza Length mm. | kg. |
|-----------------|-------|---|----------------------|-------|
| N 01 50 220 | | 39-49/58 | 220 | 0,730 |
| N 01 60 350 | | 48-59/72 | 350 | 1,810 |

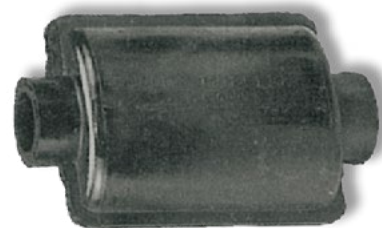

Speciale tubo per carburante

Realizzato in gomma nera, con rinforzo interno anticoppio in filati sintetici ad alta resistenza.

Special pipe for fuel

Manufactured in black rubber. With internal anti-burst reinforcement in high resistance synthetic yarns.

| Articolo - Item | €/mt. | €/ | Pressione di esercizio Working pressure Bar | Lunghezza Length mm. | mt. |
|-----------------|-------|----|---|----------------------|-----|
| N 01 08 004 | | | 10 | 8x13 | 25 |
| N 01 08 104 | | | 10 | 8x13 | 100 |
| N 01 09 004 | | | 12 | 9x15 | 25 |

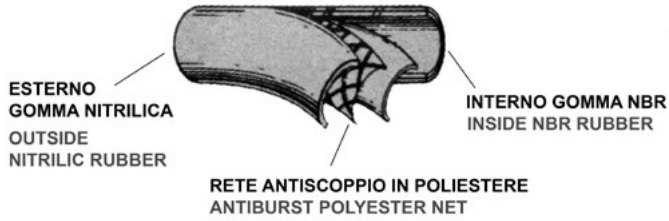

Tubazione carburante liscio

A norme CE omologata RINA ISO 7840/2013 in classe A1 (la classe A2 di qualità inferiore, non è permessa per la benzina, ma solo per il gasolio). Rinforzi di tessuti sintetici. Superficie liscia ad impressione tela.

Smooth pipe for fuel

Made in compliance with EC standards, RINA ISO 7840/2013 type-tested under class A1 (the lower class A2, is not allowed for petrol, but only for diesel fuel). Synthetic fabric reinforcement. Smooth fabric-like surface.

| Articolo - Item | €/mt. | €/ | Sez. mm. | Ø interno inner mm. | Ø esterno outer mm. | Bend radius mm. | mt. | g/mt. |
|-----------------|-------|----|----------|---------------------|---------------------|-----------------|-----|-------|
| N 01 08 784 | | | 8x17 | 8 | 17 | 50 | 40 | 0,27 |
| N 01 10 784 | | | 10x19 | 10 | 19 | 60 | 40 | 0,30 |
| N 01 16 784 | | | 16x26 | 16 | 26 | 100 | 40 | 0,50 |
| N 01 19 784 | | | 19x29 | 19 | 30 | 115 | 40 | 0,64 |
| N 01 38 784 | | | 38x52 | 38 | 52 | 380 | 20 | 1,55 |
| N 01 50 784 | | | 50x64 | 51 | 65 | 500 | 20 | 1,95 |



Tubazione carburante con spirale metallica

A norme CE omologata RINA ISO 7840/2013 in classe A1, versione flessibile anche nei grossi diametri. Rinforzi in doppia spirale metallica. Superficie ondulata.

Metal spiral pipe for fuel

Made in compliance with EC standards, RINA ISO 7840/2013 type-tested under class A1, flexible version also for large diameters. Double metal spiral reinforcement. Ondulated surface.

| Articolo - Item | €/mt. | €/ | Sezione Section mm. | Ø interno inner mm. | Bend radius mm. | mt. | g/mt. |
|-----------------|-------|----|---------------------|---------------------|-----------------|-----|-------|
| N 01 38 050 | | | 38x50 | 38 | 60 | 20 | 1,05 |
| N 01 50 063 | | | 50x63 | 51 | 75 | 20 | 1,35 |



Tubazione carburante

Realizzato in speciale tubo coestrudato con interposta calza in poliestere. Resistente fino a 15 bar. Completa di pompetta tipo maggiorato. Adatta per benzina verde.

Pipe for fuel

Manufactured in special coextruded pipe with interposed polyester sock. Resistant up to 15 bar. Complete with oversize pump. Suitable for unleaded petrol.

| Articolo - Item | €/pc. | Sezione Section mm. | Mod. | Lunghezza Length mt. |
|------------------------|-------|---------------------|--|----------------------|
| N 01 00 028 | | 10x15 | S/attacchi terminali-w/out end fittings | 2 |
| N 01 03 028 | | 10x15 | S/attacchi terminali-w/out end fittings | 3 |
| N 01 02 060 | | 10x15 | C/ 2 attacchi Yamaha-W/2 Yamaha fittings | 2 |
| N 01 02 050 NEW | | 8x13 | S/attacchi terminali-w/out end fittings | 2 |
| N 01 03 050 NEW | | 8x13 | S/attacchi terminali-w/out end fittings | 3 |



N0100028-03028
N0102050-03050



N0102060

VALVOLE | CONNECTION VALVES

Valvole di connessione

Connection valves

| Articolo - Item | €/pc. | Mod. | kg. |
|-----------------|-------|--------------|-------|
| N 01 33 003 | | 3 vie-3 ways | 0,210 |
| N 01 33 004 | | 4 vie-4 ways | 0,220 |



N0133003



N0133004

Valvole anti-sifone

Anti-siphon valves

| Articolo - Item | €/pc. | Mod. | kg. |
|-----------------|-------|------|-------|
| N 01 33 380 | | 3/8" | 0,450 |
| N 01 33 014 | | 1/4" | 0,450 |



INNESTI CARBURANTE | HOSE CONNECTORS

Innesti carburante «Scepter»

Hose connector «Scepter»

| Articolo - Item | €/pc. | Attacco-Connection | kg. |
|-----------------|-------|---|-------|
| N 01 33 450 | | Serbatoio motore-Engine tank TOHATSU NISSAN | 0,040 |
| N 01 33 503 | | Serbatoio-Tank SUZUKI | 0,300 |
| N 01 33 401 | | Serbatoio-Tank EVINRUDE JOHNSON | - |
| N 01 33 410 | | Serbatoio motore-Engine tank EVINRUDE JOHNSON | 0,030 |
| N 01 33 471 | | Serbatoio motore-Engine tank YAMAHA | 0,030 |



N0133450



N0133503



N0133401



N0133471



N0133410



INNESTI CARBURANTE | FUEL CONNECTORS

OMC/Johnson/Evinrude

Maschio con portagomma Ø 10 mm. Male with hose connector Ø 10 mm.

Articolo - Item €/pc.
N 01 14 912



OMC/Johnson/Evinrude

Maschio filettato per serbatoio. Threaded male for fuel tank.

Articolo - Item €/pc.
N 01 00 052



OMC/Johnson/Evinrude

Femmina con portagomma Ø 10 mm. Female with hose connector Ø 10 mm.

Articolo - Item €/pc.
N 01 00 415



OMC/Johnson/Evinrude

Femmina con portagomma Ø 8 mm. 5/16". Female with hose connector Ø 8 mm. 5/16".

Articolo - Item €/pc.
N 01 00 064



OMC/Johnson/Evinrude

Connettore maschio. Male connector.

Articolo - Item €/pc.
N 01 00 053



Mercury/Mariner

Maschio filettato per serbatoio. Threaded male for fuel tank.

Articolo - Item €/pc.
N 01 00 060



Mercury/Mariner

Maschio con portagomma Ø 10 mm. Male with hose connector Ø 10 mm.

Articolo - Item €/pc.
N 01 14 911



Mercury/Mariner

Femmina con portagomma Ø 10 mm. Female with hose connector Ø 10 mm.

Articolo - Item €/pc.
N 01 00 409



Selva/Tohatsu/Nissan

Femmina con portagomma Ø 10 mm. 3/8" (Moeller 033492) Female with hose connector Ø 10 mm. (Moeller 033492)

Articolo - Item €/pc.
N 01 11 051



Selva/Tohatsu/Nissan

Maschio con portagomma Ø 10 mm. Male with hose connector Ø 10 mm.

Articolo - Item €/pc.
N 01 00 496



Yamaha/Mariner/Mercury

Maschio con portagomma Ø 10 mm. Male with hose connector Ø 10 mm.

Articolo - Item €/pc.
N 01 14 910



Yamaha/Mariner/Mercury

Maschio filettato per serbatoio. Threaded male for fuel tank.

Articolo - Item €/pc.
N 01 06 910



Yamaha/Mariner/Mercury

Femmina con portagomma Ø 8 mm. 5/16". Female with hose connector Ø 8 mm. 5/16".

Articolo - Item €/pc.
N 01 22 004



Yamaha/Mariner/Mercury

Femmina con portagomma Ø 8 mm. 5/16". Female with hose connector Ø 8 mm. 5/16".

Articolo - Item €/pc.
N 01 11 004



Yamaha/Mariner/Mercury

Connettore maschio. Male connector.

Articolo - Item €/pc.
N 01 00 051



Honda

Femmina con portagomma Ø 10 mm. Female with hose connector Ø 10 mm.

Articolo - Item €/pc.
N 01 00 482



Honda

Maschio filettato lato motore. Threaded male engine side.

Articolo - Item €/pc.
N 01 00 483



Honda

Femmina aggancio quadrato con portagomma Ø 10 mm. Female with hose connector Ø 10 mm.

Articolo - Item €/pc.
N 01 00 068



Honda

1/4" NPT serbatoio. (Moeller N. 033496) 1/4" NPT fuel tank. (Moeller N. 033496)

Articolo - Item €/pc.
N 01 00 055



Honda

Ø 10-3/8" serbatoio. (Moeller N. 033498) Ø 10-3/8" fuel tank. (Moeller N. 033498)

Articolo - Item €/pc.
N 01 00 065



Suzuki

Connettore femmina 3/8" Ø 10 mm. Female connector 3/8" Ø 10 mm.

Articolo - Item €/pc.
N 01 00 067



SFIATI SERBATOI | FUEL VENTS

Sfiati carburante in acciaio inox lucidato a specchio

Completi di retina antifiama e portagomma. Conformi a norme RINA e CE.

Mirror polished stainless steel fuel vents

Complete with flame retardant screen and hose adapter. In compliance with RINA & CE.

| Articolo-Item | €/pc. | Articolo-Item | €/pc. | Per tubo |
|-----------------|-------|-----------------------|-------|----------------|
| Dritto-Straight | | angolo 90°-angled 90° | | For pipe Ø mm. |
| N 29 16 135 | | N 28 16 781 | | 16 |
| N 29 19 784 | | N 28 19 782 | | 19 |

AISI 316 CE

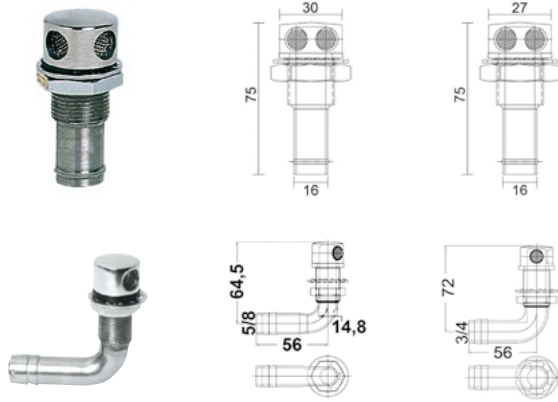

Sfiati carburante in acciaio inox a filo

Conforme a norme RINA e CE.

Stainless steel wire fuel vents

In compliance with RINA & CE rules.

| Articolo - Item | €/pc. | Mod. | A mm. | B mm. | C mm. | D mm. | E mm. | E mm. |
|-----------------|-------|-----------------|-------|-------|-------|-------|-------|-------|
| | | | | | | | max | min |
| N 29 16 790 | | Dritto-Straight | 16 | 76 | 41 | 44 | 41 | 13 |
| N 29 19 794 | | Dritto-Straight | 19 | 76 | 41 | 44 | 41 | 13 |
| N 28 16 791 | | Curvo-Bent | 16 | 76 | 47 | 47 | 41 | 13 |
| N 28 19 792 | | Curvo-Bent | 19 | 76 | 47 | 47 | 41 | 13 |

AISI 316 CE

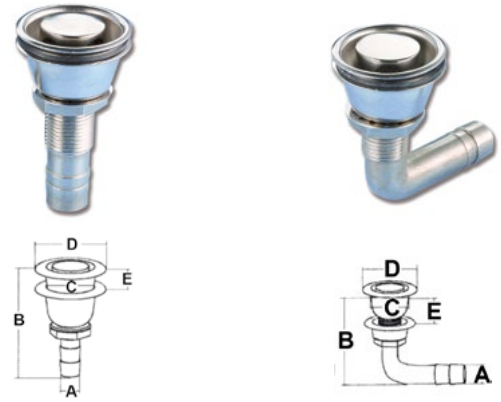

Sfiati carburante in ottone cromato

Conformi a regolamenti RINA.

Chromed brass fuel vents

In compliance with RINA rules.

| Articolo - Item | €/pc. | Mod. | Portagomma | H mm. |
|-----------------|-------|-----------------|----------------------|-------|
| | | | Hose connector Ø mm. | |
| N 28 15 120 | | Dritto-Straight | - | 44 |
| N 29 18 080 | | Curvo-Bent 90° | 16 | 73 |

AISI 316 CE



Sfiato carburante in ottone cromato a filo

Conforme a regolamenti RINA.

Chromed brass wire fuel vent

In compliance with RINA rules.

| Articolo - Item | €/pc. | Mod. | Portagomma | Lato | H tot. |
|-----------------|-------|----------------|----------------------|----------|--------|
| | | | Hose connector Ø mm. | Side | mm. |
| N 29 16 002 | | Curvo-Bent 90° | 16 | DX-Right | 95 |

AISI 316 CE



Sfiato ovale dritto per serbatoi Straight oval vent for tank

| Articolo - Item | €/pc. | A mm. | B mm. | C mm. | D mm. | E mm. |
|-----------------|-------|-------------|-------------|--------------|-------|---------------|
| N 29 74 080 | | 16 (41/64") | 29 (15/32") | 83 (3 9/32") | 60x40 | 40 (1 19/32") |

AISI 316 CE

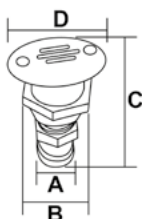

Sfiato ovale 90° per serbatoi 90° oval vent for tank

| Articolo - Item | €/pc. | A mm. | B mm. | C mm. | D mm. | E mm. | F mm. |
|-----------------|-------|-------------|-------------|--------------|-------|---------------|---------------|
| N 29 74 063 | | 16 (41/64") | 29 (15/32") | 83 (3 9/32") | 60x40 | 40 (1 19/32") | 50 (1 63/64") |

AISI 316 CE

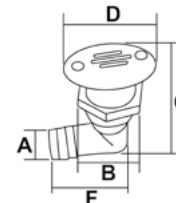

Tappe imbarco «Galaxy»

Corpo realizzato in tecnopolimero. Laccetto di tenuta sostituibile in caso di rottura. Tassello colorato per una discreta ma efficace riconoscibilità. Corrispondente alle norme ISO 8099.

Fuel deck plug «Galaxy»

Body manufactured in technopolymer. Replaceable sealing strap in case of breakage. Colored tile for easily identify the plug model. In compliance with ISO 8099 rules.

| Articolo - Item | Articolo - Item | Articolo - Item | Articolo - Item | Mod. | Colore Colour | A mm. | B mm. | C mm. | D mm. |
|-----------------|-----------------|-----------------|-----------------|-----------------|---------------|-------|-------|-------|-------|
| White Ral 9003 | Cream Ral 9010 | Nero-Black | Aisi 316 | | | | | | |
| N 28 38 074 | N 28 38 033 | N 28 38 080 | N 28 38 032 | Acqua-Water | Blue | 38 | 55 | 55 | 90 |
| N 29 38 074 | N 29 38 033 | N 29 38 080 | N 29 38 032 | Carburante-Fuel | Red | 38 | 55 | 55 | 90 |
| N 27 38 074 | - | N 27 38 080 | N 27 38 032 | Scarico-Waste | Black | 38 | 55 | 55 | 90 |
| N 30 38 074 | - | N 30 38 080 | N 30 38 032 | Diesel | Yellow | 38 | 55 | 55 | 90 |
| N 30 74 050 | N 30 33 050 | N 30 80 050 | N 30 32 050 | Diesel | Yellow | 50 | 55 | 55 | 90 |
| N 27 74 050 | N 27 33 050 | N 27 80 050 | N 27 32 050 | Scarico-Waste | Black | 50 | 55 | 55 | 90 |
| N 28 50 074 | - | N 28 80 050 | N 28 32 050 | Acqua-Water | Blue | 50 | 55 | 55 | 90 |
| N 29 74 050 | N 29 33 050 | N 29 80 050 | N 29 32 050 | Carburante-Fuel | Red | 50 | 55 | 55 | 90 |

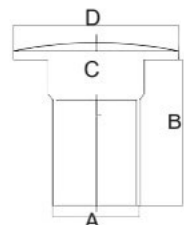

Kit nicchia carburante

Con tappo carburante.

Fuel case kit

With fuel plug.

| Articolo - Item | €/Kit | Nicchia-Case | Tappo-Plug | Collo-Neck Ø mm. | A mm. | B mm. | C mm. | D mm. | E mm. |
|-----------------|-------|-------------------|-------------------|------------------|-------|-------|-------|-------|-------|
| N 29 38 033 C | | L5333162-Ral 9010 | N2938033-Ral 9010 | 38 | 165 | 125 | 160 | 200 | 90 |
| N 29 33 050 C | | L5333162-Ral 9010 | N2933050-Ral 9010 | 50 | 165 | 125 | 160 | 200 | 90 |
| N 29 38 074 C | | L5374162-Ral 9003 | N2938074-Ral 9003 | 38 | 165 | 125 | 160 | 200 | 90 |
| N 29 32 033 C | | L5333162-Ral 9010 | N2938032-Aisi 316 | 38 | 165 | 125 | 160 | 200 | 90 |
| N 29 32 050 C | | L5333162-Ral 9010 | N2932050-Aisi 316 | 50 | 165 | 125 | 160 | 200 | 90 |
| N 29 32 074 C | | L5374162-Ral 9003 | N2938032-Aisi 316 | 38 | 165 | 125 | 160 | 200 | 90 |

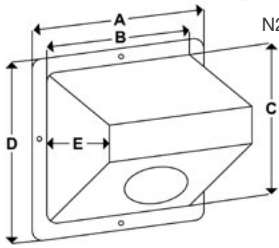
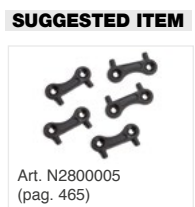

Kit 5 chiavi di ricambio

Kit of 5 spare keys

| Articolo - Item | €/Kit |
|-----------------|-------|
| N 28 00 005 | |





Tappo imbarco in nylon nero

Sistema di apertura maniglia winch. Provvisto di adesivi acqua e carburante.

Black nylon fuel deck plug

Winch handle opening system. Complete with water and fuel stickers.

| Articolo - Item | €/pc. | Ø pollici-inches | Collo-Neck Ø mm. | Flangia-Flange Ø mm. | Lunghezza collo Neck length mm. |
|-----------------|-------|------------------|------------------|----------------------|---------------------------------|
| N 28 33 000 | | 1 1/2" | 38 | 88 | 65 |



Tappo imbarco in nylon nero

Sistema di apertura a moneta. Provvisto di adesivi acqua e carburante.

Black nylon fuel deck plug

Coin opening system. Complete with water and fuel stickers.

| Articolo - Item | €/pc. | Ø pollici-inches | Collo-Neck Ø mm. | Flangia-Flange Ø mm. | Lunghezza collo Neck length mm. |
|-----------------|-------|------------------|------------------|----------------------|---------------------------------|
| N 29 50 080 | | 1 1/2" | 50 | 88 | 65 |



Tappo imbarco a scatto

Fabbricato in materiale plastico. Provvisto di pulsante a scatto per apertura.

Snap-in opening fuel deck plug

Manufactured in plastic material. Complete with opening snap-in button.

| Articolo - Item | €/pc. | Ø pollici-inches | Collo-Neck Ø mm. | Tappo-Plug Ø mm. | Lunghezza collo Neck length mm. |
|-----------------|-------|------------------|------------------|------------------|---------------------------------|
| N 27 07 080 | | 1 1/2" | 38 | 85 | 80 |



MOD. WASTE



Tappo a filo in ottone cromato con apertura a ribalta

Lo speciale sistema di apertura a ribalta evita chiavi, monete, cacciaviti ed ogni altro strumento. Regolamentare RINA.

Chromed brass deck filler for flush mounting

The special rotating lever opening system avoids the need for keys, coins, screwdrivers or any other device. Certified by RINA.

| Articolo - Item | €/pc. | Mod. | Collo-Neck Ø mm. |
|-----------------|-------|------|------------------|
| N 29 35 085 | | FUEL | 50 |



Tappo rifornimento in ottone cromato

Speciale sistema di apertura che evita l'uso di chiavi, monete od altro. Progettato in modo che il tappo mascheri completamente la flangia avvitata, migliorando la tenuta dell'acqua. Conforme ISO 8099/1C. Completo di catenella interna, Ø massimo 88 mm. Regolamentare RINA.

Chromed brass deck filler for flush mounting

Complete with special opening system that avoids the use of keys, coins or any other device. Designed to cover the flange completely, thus improving its watertight features. In accordance with ISO 8099/1C standards. With small internal chain, max Ø 88 mm. RINA type-approved.

| Articolo - Item | €/pc. | Mod. | Collo-Neck Ø mm. |
|-----------------|-------|-------|------------------|
| N 28 38 034 | | WATER | 38 |



Tappi rifornimento in acciaio inox Aisi 316 con sfiato incorporato

Aisi 316 stainless steel refuel plugs with built-in vent

Tramite un ingegnoso sistema, il collo del tappo si monta in coperta con un unico foro.

With special clever system, the plug neck can be mounted on the deck with just one hole.

| Articolo - Item | €/pc. | Mod. | Collo-Neck Ø mm. | Foro montaggio Mounting hole Ø mm. | Sfiato-Vent Ø mm. | Tappo-Plug Ø mm. | Sporgenza Overhang mm. | Ghiera fissaggio Mounting ring Ø mm. |
|-----------------|-------|--------|---------------------|---------------------------------------|----------------------|---------------------|---------------------------|---|
| N 30 38 148 | | DIESEL | 38 | 50 | 16 | 82 | 14 | 74 |
| N 28 38 168 | | WATER | 38 | 50 | 16 | 82 | 14 | 74 |
| N 27 38 158 | | WASTE | 38 | 50 | 16 | 82 | 14 | 74 |

AISI 316



Tappi imbarco in acciaio inox Aisi 316 microfusi e lucidati a specchio

Precision cast mirror polished Aisi 316 stainless steel deck fillers

Provisti di doppia chiave. Regolamentari RINA.

Complete with double key. Certified by RINA.

| Articolo - Item | €/Kit | Mod. | Versione-Version | A Ø mm. | B mm. | C mm. | D mm. |
|-----------------|-------|--------|------------------|---------|-------|-------|-------|
| N 29 38 662 | | FUEL | Dritta-Straight | 38 | 85 | 50 | 87 |
| N 30 38 662 | | DIESEL | Dritta-Straight | 38 | 85 | 50 | 87 |
| N 27 38 662 | | WASTE | Dritta-Straight | 38 | 85 | 50 | 87 |
| N 28 38 662 | | WATER | Dritta-Straight | 38 | 85 | 50 | 87 |
| N 29 50 662 | | FUEL | Dritta-Straight | 50 | 87 | 50 | 87 |
| N 30 50 662 | | DIESEL | Dritta-Straight | 50 | 87 | 50 | 87 |
| N 27 50 662 | | WASTE | Dritta-Straight | 50 | 87 | 50 | 87 |
| N 28 50 662 | | WATER | Dritta-Straight | 50 | 87 | 50 | 87 |

AISI 316 **NEW**

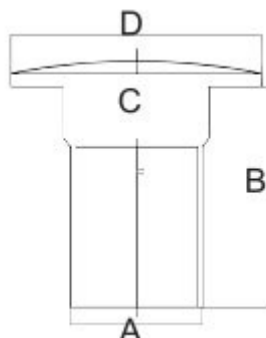

Tappi imbarco in acciaio inox Aisi 316 microfusi e lucidati a specchio

Precision cast mirror polished Aisi 316 stainless steel deck fillers

Modello a levetta. Finiture accuratissime.

Lever model. Very accurate finishes.

| Articolo - Item | €/Kit | Mod. | Versione-Version | A mm. | B mm. | C mm. | D mm. |
|-----------------|-------|-------|-----------------------|-------|-------|-------|-------|
| N 29 38 503 | | FUEL | Dritta-Straight | 38 | 85 | 50 | 87 |
| N 27 38 563 | | WASTE | Dritta-Straight | 38 | 85 | 50 | 87 |
| N 29 38 348 | | FUEL | Inclinata-Sloping 30° | 38 | 85 | 50 | 87 |
| N 29 50 348 | | FUEL | Inclinata-Sloping 30° | 50 | 85 | 50 | 87 |
| N 28 38 348 | | WATER | Inclinata-Sloping 30° | 38 | 87 | 50 | 87 |
| N 29 50 515 | | FUEL | Dritta-Straight | 50 | 85 | 50 | 87 |
| N 28 38 543 | | WATER | Dritta-Straight | 38 | 85 | 50 | 87 |

AISI 316 **NEW**

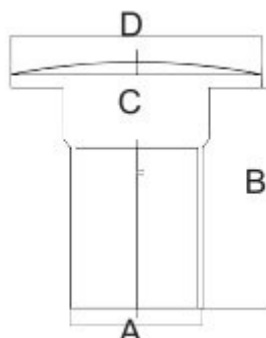

FILTRI | FILTERS

Filtro benzina con cartuccia a perdere da 10 micron tipo Mercury

Provisto di portagomma conici, autobloccanti e autosigillanti. Equivalente Mercury 35-60494A4, 35-802893Q, 35-807172. Raccordi da 10 mm. inclusi.



| Articolo - Item | €/pc. | Supporto testa Head support | H mm. | Sporgenza Overhang mm. | Cartuccia Cartridge Ø mm. | Filetto cartuccia Cartridge thread | Portata L/h con pressione Flow L/h at pressure | | | Cartuccia ricambio Spare cartridge |
|-----------------|-------|--------------------------------|----------|------------------------------|---------------------------------|---------------------------------------|---|---------|---------|---------------------------------------|
| | | | | | | | 0,49PSI | 1,47PSI | 2,45PSI | |
| N 01 80 032 | | Aluminium | 145 | 110 | 92 | 11/16" | 182 | 315 | 404 | N0174032 |



10 micron gasoline filter with disposable cartridge Mercury type

Supplied with conical, self-locking and self-sealing hose adaptor. Equivalent Mercury 35-60494A4, 35-802893Q, 35-807172. Fittings 10 mm. included.

COMPLETO DI-COMLETE WITH



Art. N0174032
(pag. 471)

Art. N0184212
(pag. 471)

Filtro benzina con cartuccia a perdere da 10 micron tipo OMC

Provisti di portagomma conici, autobloccanti e autosigillanti. Equivalente OMC. Raccordi da 10 mm. inclusi.



| Articolo - Item | €/pc. | Supporto testa Head support | H mm. | Sporgenza Overhang mm. | Cartuccia Cartridge Ø mm. | Filetto cartuccia Cartridge thread | Portata L/h con pressione Flow L/h at pressure | | | Cart. ricambio Spare cartridge |
|-----------------|-------|--------------------------------|----------|------------------------------|---------------------------------|---------------------------------------|---|---------|---------|-----------------------------------|
| | | | | | | | 0,49PSI | 1,47PSI | 2,45PSI | |
| N 01 14 553 | | Aluminium | 145 | 110 | 92 | 11/16" | 182 | 315 | 404 | N0114554 |



10 micron gasoline filter with disposable cartridge Mercury type

Supplied with conical, self-locking and self-sealing hose adaptor. Equivalent OMC. Fittings 10 mm. included.

COMPLETO DI-COMLETE WITH



Art. N0114554
(pag. 471)

Art. N0184212
(pag. 471)

Filtro gasolio tipo CAV con spurgo

Filtro separatore acqua-carburante. Costruito in accordo con norma ISO 10088. Testa + vaschetta con scarico acqua fabbricati in alluminio. Completo di raccordi.



N0121016

Diesel filter type CAV with water drain

Water-fuel filter separator. Made in compliance with the ISO 10088 standard. Aluminium head and water drain container. With fittings.

| Articolo - Item | €/pc. | Ampolla | Portata L/h Flow L/h | | Filetto MB MB thread | Lunghezza Length mm. | Cartuccia ricambio Spare cartridge | Mod. ampolla |
|-----------------|-------|---------|-------------------------|-----|-------------------------|-------------------------|---------------------------------------|--------------|
| | | | Ottimale-Constant | Max | | | | |
| N 01 21 016 | | Plastic | 50 | 100 | 14 | 175x100 | N0114969 | N0123013 |
| N 01 14 016 | | Alu | 50 | 100 | 14 | 175x100 | N0114969 | N0123296 |



COMPLETO DI-COMLETE WITH



Art. N0114969
(pag. 471)

AMPOLLE
(pag. 471)

Art. N0122022
(pag. 471)

Art. N0100116
(pag. 471)

N0114016

Filtro benzina + separatore acqua/carburante tipo Yamaha Mini

Testa in alluminio, vaschetta trasparente, spurgo con sistema rapido. Consigliato per motori fino a 200 HP - Equivalente Yamaha 2W-114-00-00. Completo portagomma 8 mm. Equivalente Yamaha MAR - MINIF - IL - TR.



Petrol filter + water/fuel separator Yamaha Mini type

Aluminium head, transparent tank, rapid drain system. Recommended for engines up to 200 HP - Equivalent to Yamaha 2W-114-00-00. Fitted with 8-mm hose adapter. Equivalent Yamaha MAR - MINIF - IL - TR.

| Articolo - Item | €/pc. | H mm. | Sporgenza Overhang mm. | Ø mm. | Filetto cartuccia Cartridge thread | Portata L/h con pressione Flow L/h at pressure | | | Hose connector Portagomma Ø mm INCLUDED | Cartuccia ricambio Spare cartridge |
|-----------------|-------|----------|------------------------------|----------|---------------------------------------|---|---------|---------|---|---------------------------------------|
| | | | | | | 0,49PSI | 1,47PSI | 2,45PSI | | |
| N 01 14 973 | | 230 | 90 | 75 | 13/16" | 200 | 316 | 406 | 2 da 8 | N0114968 |



COMPLETO DI-COMLETE WITH



Art. N0114968
(pag. 471)

Art. N0184212
(pag. 471)



FILTER

we are the filters by 

FILTRI | FILTERS

Filtro separatore acqua/carburante tipo Yamaha

Con cartuccia ad alta capacità da 10 micron. Testa in alluminio. Universale per ogni tipo di motore. Completo di portagomma conici, autobloccanti e autosigillanti, di tappi per chiudere i passaggi inutilizzati e fascette inox. Equivalente Yamaha MAR - FUELF - IL - TR. Portagomma Ø 10 mm. inclusi.

Water/fuel separating filter Yamaha type

Fitted with 10-micron high-capacity cartridge. Aluminium head. Universal size to fit any type of engine. With conical, self-locking and self-sealing hose adaptors, caps to close unused passages, and stainless steel clamps. Equivalent Yamaha MAR - FUELF - IL - TR. Hose adapter Ø 10 mm. included.

| Articolo - Item | €/pc. | Micron cartuccia Cartridge micron | Ø mm. | H mm. | Sporgenza Overhang mm. | Tappo di spurgo Drain plug | Filetto cartuccia Cartridge thread | Portata L/h con pressione Flow L/h at pressure | | | Vaschetta acqua Water tray | Indicato per Suitable for | Cartuccia ricambio Spare cartridge |
|-----------------|-------|--------------------------------------|----------|----------|------------------------------|-------------------------------|---------------------------------------|---|---------|---------|-------------------------------|------------------------------|---------------------------------------|
| | | | | | | | | 0,49PSI | 1,47PSI | 2,45PSI | | | |
| N 01 14 573 | | 10 | 92 | 290 | 110 | Plastic | 11/16" | 206 | 331 | 414 | N0114564 | Benzina-Fuel | N0114768 |



COMPLETO DI-COMLETE WITH



Art. N0114768 (pag. 471)

Art. N0114564 (pag. 471)

Art. N0184212 (pag. 471)



Filtro separatore acqua/carburante universale tipo Racor 3213/ Mercury

Con supporto in alluminio e cartuccia standard. Provvisto di portagomma conici, autobloccanti e autosigillanti. Portagomma Ø 10 mm. inclusi.

Universal water/fuel separating filter Racor 3213/Mercury type

With aluminium support and standard cartridge. With conical, self-locking and self-sealing hose adaptors. Hose adapter Ø 10 mm. included.

| Articolo - Item | €/pc. | Micron cartuccia Cartridge micron | Ø mm. | H mm. | Sporgenza Overhang mm. | Tappo di spurgo Drain plug | Filetto cartuccia Cartridge thread | Portata L/h con pressione Flow L/h at pressure | | | Vaschetta acqua Water tray | Indicato per Suitable for | Cartuccia ricambio Spare cartridge |
|-----------------|-------|--------------------------------------|----------|----------|------------------------------|-------------------------------|---------------------------------------|---|---------|---------|-------------------------------|------------------------------|---------------------------------------|
| | | | | | | | | 0,49PSI | 1,47PSI | 2,45PSI | | | |
| N 01 14 573 | | 10 | 93 | 220 | 100 | Black plastic | 11/16" | 192 | 324 | 410 | N0114564 | Benzina-Fuel | N0114568 |



COMPLETO DI-COMLETE WITH



Art. N0114568 (pag. 471)

Art. N0114564 (pag. 471)

Art. N0184212 (pag. 471)



Filtro separatore acqua/carburante universale tipo Racor S3227-1

Con supporto in alluminio e cartuccia standard. Provvisto di portagomma conici, autobloccanti e autosigillanti.

Universal water/fuel separating filter Racor S3227-1 type

With aluminium support and standard cartridge. With conical, self-locking and self-sealing hose adaptors.

| Articolo - Item | €/pc. | Micron cartuccia Cartridge micron | Ø mm. | H mm. | Sporgenza Overhang mm. | Tappo di spurgo Drain plug | Filetto cartuccia Cartridge thread | Portata L/h con pressione Flow L/h at pressure | | | Vaschetta acqua Water tray | Indicato per Suitable for | Cartuccia ricambio Spare cartridge |
|-----------------|-------|--------------------------------------|----------|----------|------------------------------|-------------------------------|---------------------------------------|---|---------|---------|-------------------------------|------------------------------|---------------------------------------|
| | | | | | | | | 0,49PSI | 1,47PSI | 2,45PSI | | | |
| N 01 14 866 | | 10 | 93 | 220 | 100 | Black plastic | 1"-14 | 192 | 324 | 410 | N0114564 | Benzina-Fuel | N0114865 |



COMPLETO DI-COMLETE WITH



Art. N0114865 (pag. 471)

Art. N0114564 (pag. 471)

Art. N0184212 (pag. 471)



FILTRI | FILTERS

Filtro separatore

Completo di cartuccia intercambiabile.
Per motori fino a 3500cc.
Dimensioni H 230 x Ø 110 mm.

Water separating fuel filter

Complete with interchangeable cartridge.
For engines up to 3500cc.
Size H 230 x Ø 110 mm.

| Articolo - Item | €/pc. | Mod. | kg. |
|-----------------|-------|-------------------------------------|-------|
| N 01 33 314 | | Filtro in composito-Plastic filter | 0,080 |
| N 01 33 339 | | Filtro in alluminio-Alu filter | 2,500 |
| N 01 33 336 | | Vetro di ricambio-Replacement glass | 0,500 |
| N 01 33 337 | | Bowl in alluminio-Alu bowl | 0,280 |



N0133314/336



N0133339/337

Filtro cartuccia completo

Completo di raccordi.
Dimensioni H 160 x Ø 100 mm.

Fuel filter

Complete with fittings.
Size H 160 x Ø 100 mm.

| Articolo - Item | €/pc. | kg. |
|-----------------|-------|-------|
| N 01 14 614 | | 0,610 |



Filtro separatore acqua/carburante

Con vaschetta trasparente smontabile per la sostituzione della cartuccia filtrante o sua pulizia.

Water/fuel separating filter

With transparent container that can be taken off to clean it or to replace the filtering cartridge.

| Articolo - Item | €/pc. | Micron | Ø mm. | H mm. | Vite spurgo Drain screw | Testa Head | Versione Version | Portata L/h con pressione Flow L/h at pressure | | | Portagomma inclusi Included hose adapter | Vetro c/cartuccia Glass w/cartridge | Cartuccia ricambio Spare cartridge |
|-----------------|-------|--------|-------|-------|-------------------------|------------|------------------|--|--------|---------|--|-------------------------------------|------------------------------------|
| | | | | | | | | 0,49PSI | 1,5PSI | 2,45PSI | | | |
| N 01 14 371 | | 10 | 110 | 190 | SI-YES | Plastic | Fuel filter | 205 | 333 | 420 | 11/16"UNC 2x10 mm. | N0114368 | N0114372 |
| N 01 14 471 | | 25 | 110 | 190 | SI-YES | Alu | Diesel filter | 205 | 333 | 420 | 11/16"UNC 2x10 mm. | - | N0114373 |
| N 01 14 871 | | 10 | 110 | 150 | NO | Alu | Fuel | 205 | 333 | 420 | 2x10 mm. | N0114869 | N0114372 |
| N 01 14 370 | | 10 | 110 | 190 | SI-YES | Alu | Fuel | 205 | 333 | 420 | 1/14"UNC 2x10 mm. | N0114368 | N0114372 |



N0114371



N0114471



N0114871



N0114370

COMPLETO DI-COMPLETE WITH



CARTUCCE (pag. 471)



VETRO CON CARTUCCIA (pag. 471)

Filtri volanti in plastica trasparenti

Adatti sia per benzina che per nafta.

Fuel filters

Suitable for petrol and naphtha.



| Articolo - Item | €/pc. | Mod. | Portata max Lt/h | Portagomma mm. |
|-----------------|-------|---------------|------------------|----------------|
| N 01 13 271 | | Piccolo-Small | 50 | 3/8" |
| N 01 13 281 | | Grande-Large | 150 | 1/4"-5/16" |



Filtro aria Volvo a pannello

Panel air filter Volvo

| Articolo - Item | €/pc. | Rif. originale Original ref. |
|-----------------|-------|------------------------------|
| N 01 14 185 | | 876185 |



Filtro aria Volvo D4/D6/D9

Air filter Volvo D4/D6/D9

| Articolo - Item | €/pc. | Rif. originale Original ref. |
|-----------------|-------|------------------------------|
| N 01 14 999 | | 3818541/21702999 |



Filtri aria per motori Volvo

Air filters for Volvo engines

| Articolo - Item | €/pc. | D1 mm. | D2 mm. | H2 mm. | H1 mm. | Rif. orig. Orig. ref. |
|-----------------|-------|--------|--------|--------|--------|-----------------------|
| N 01 14 488 | | 206 | 98 | 100 | 90 | 858488-0 |
| N 01 14 645 | | 155 | 90 | 98 | 85 | 3582358/21646645 |



N0114488



N0114645

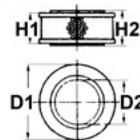



FILTER

we are the filters by 

FILTRI | FILTERS

Cartuccia di ricambio acqua/carburante tipo Yamaha Spare cartridge water/fuel Yamaha type

| Articolo - Item | €/pc. |
|-----------------|-------|
| N 01 14 768 | |

 made by 



Cartuccia di ricambio acqua/carburante tipo Racor 3213 Spare cartridge water/fuel Racor 3213 type

| Articolo - Item | €/pc. |
|-----------------|-------|
| N 01 14 568 | |

 made by 



Cartuccia di ricambio acqua/carburante tipo Racor 3227 Spare cartridge water/fuel Racor 3227 type

| Articolo - Item | €/pc. |
|-----------------|-------|
| N 01 14 865 | |

 made by 



Cartuccia di ricambio acqua/carburante tipo Yamaha Mini Spare cartridge water/fuel Yamaha Mini type

| Articolo - Item | €/pc. |
|-----------------|-------|
| N 01 14 968 | |

 made by 



Cartuccia di ricambio acqua/carburante tipo CAV Spare cartridge water/fuel CAV type

| Articolo - Item | €/pc. |
|-----------------|-------|
| N 01 14 969 | |

 made by 



Cartuccia di ricambio carburante tipo OMC Spare cartridge fuel OMC type

| Articolo - Item | €/pc. |
|-----------------|-------|
| N 01 14 554 | |

 made by 



Cartuccia di ricambio olio tipo Mercury Spare cartridge oil Mercury type

| Articolo - Item | €/pc. |
|-----------------|-------|
| N 01 14 559 | |

 made by 



Cartuccia di ricambio carburante tipo Mercury Spare cartridge fuel Mercury type

| Articolo - Item | €/pc. |
|-----------------|-------|
| N 01 74 032 | |

 made by 



Raccordi per filtri Fittings for filters

| Articolo - Item | €/pc. | Filetto | Thread |
|-----------------|-------|---------|--------|
| N 01 84 212 | | 10 | 1/2" |

 made by 



Raccordi per filtri Fittings for filters

| Articolo - Item | €/pc. | Filetto | Thread |
|-----------------|-------|---------|--------|
| N 01 00 116 | | 10 | M14 |

 made by 



Testa filtri CAV Filter head CAV

| Articolo - Item | €/pc. |
|-----------------|-------|
| N 01 22 022 | |

 made by 



Ampolla filtri CAV trasparente Transparent filter bowl CAV

| Articolo - Item | €/pc. |
|-----------------|-------|
| N 01 23 013 | |

 made by 



Ampolla filtri acqua/carburante Filter bowl water/fuel

| Articolo - Item | €/pc. |
|-----------------|-------|
| N 01 14 564 | |

 made by 



Ampolla filtri CAV alluminio Filter bowl CAV aluminium

| Articolo - Item | €/pc. |
|-----------------|-------|
| N 01 23 296 | |

 made by 



Vetro con cartuccia Glass with cartridge

| Articolo - Item | €/pc. | Ideale per Suitable for |
|-----------------|-------|-------------------------|
| N 01 14 368 | | N0114371-370 |
| N 01 14 869 | | N0114871 |

 made by 



Cartuccia Cartridge

| Articolo - Item | €/pc. | Ideale per Suitable for |
|-----------------|-------|-------------------------|
| N 01 14 372 | | N0114371-370 |
| N 01 14 373 | | N0114871 |

 made by 



AREA DIDATTICA | EDUCATIONAL AREA

Grazie alle tabelle di seguito riportate, puoi ottenere il modello di filtro per il tuo motore, anche senza conoscere i codici originali.

Thanks to the tables below, you can get the right filter for your engine, even without knowing the original codes.

FILTRI OLIO / NAFTA / BENZINA / ARIA VOLVO - FILTERS OIL / NAPHTHA / PETROL / AIR VOLVO

| MOTORE ENGINE | FILTRO OLIO OIL FILTER | | FILTRO CARBURANTE FUEL FILTER | | FILTRO ARIA AIR FILTER | |
|------------------|---------------------------|-----|----------------------------------|-----|---------------------------|-----|
| | REF. | OEM | REF. | OEM | REF. | OEM |

VOLVO DIESEL

| | | | | | | |
|---|-----------------------------------|------------------------------|--------------------------------------|------------------------------|----------|---------------------------|
| MD 1A/B ; 2A/B ; 5A/B/C ; 11C/D | N0114377 | 834337 ; 22057107 | N0114078 | 829913 ; 3581078 | - | - |
| MD 6A/B | N0114377 | 834337 ; 22057107 | N0114987 | 3825133 ; 21492771 | - | - |
| MD 7A/B | N0114377 | 834337 ; 22057107 | N0114987 | 3825133 ; 21492771 | - | - |
| MD 3B/17C | N0114377 | 834337 ; 22057107 | - | 829913 | - | - |
| MD 21A/B ; AQD 21A/B | N0114621 | 3581621 ; 21549544 | N0114078 | 3581078 | - | - |
| MD 22A/B ; TDM 22A/B ; TAMD 22A | N0114857 | 3517857 | N0114740 (CON SPURGO) N0114078 | 3840335 ; 21624740 ; 3581078 | - | - |
| MD 30 A/B/D/AQ ; TAMD 30A/B/D/AQ ; TMD 30A/B/D/AQ ; AQAD30A | N0114857 | 3517857 | N0114987 | 3825133 ; 21492771 | - | - |
| AQAD 31A ; AD31A/B/D/XD/P/L-A ; MD 31A ; TMD 31A/B/D/L-A ; TAMD 31A/B/D/P/L/M/S-A ; KAD32A | N0114857 | 3517857 | N0114987 | 3825133 ; 21492771 | - | - |
| MD 40A ; TMD 40A/B/C ; TAMD 40A/B ; AQD4 0A ; AQAD 40A/B | N0114034 | 471034 | N0114501 | 3840335 ; 21624740 | - | - |
| TMD 41A/B/D/L-A ; TAMD 41A/B/D ; D41A/B/D/L-A ; AD41A/B/D ; AQ41A ; AQA41A | N0114034 | 471034 | N0114501 | 3840335 ; 21624740 | - | - |
| TAMD 41P/L/M/H-A/H-B ; AD41*P/L-A | N0114034 | 471034 | N0114501 | 3840335 ; 21624740 | - | 858488 ; 21646645 3582358 |
| KAD42A/B/P-A ; KAMD42/B/P-A ; KAD43P-A ; KAMD43P-A ; KAD44P-A/P-C ; KAD300A ; KADM44P-A/P-B/P-C ; KADM300A | N0114974 | 4785974 ; 423135 | N0114501 | 3840335 ; 21624740 | - | 876185 |
| 2001 ; 2002 ; 2003 ; 2003T | N0114377 | 834337 ; 22057107 | - | 829913 ; 3581078 | - | - |
| MD 2010/2020/2030/2040 | - | - | N0114078 | 861477 ; 3581078 | - | - |
| D1-30 ; D2-40 | N0114528 | 3840525 | - | - | - | - |
| D2-55 ; D2-75 | N0114528 | 3840525 | - | - | - | - |
| D3 YEAR 2009 | - | - | - | - | N0114645 | 3582358 ; 21646645 |
| D4 ; D6 | N0114848 N0114733 (BY PASS) | 3582732 ; 22030848 ; 3582733 | N0114443 | 3583443 ; 21718912 | N0114999 | 3118541 ; 21702999 |
| TAMD 61A/62A/63L-A/63P-A ; TAMD 71A/B ; TAMD 73P-A / 73WJ-A ; TAMD 72P-A/72WJ-A/72A ; TAMD 74A/A-A/A-B/C-A/C-B/L-A/L-B ; TAMD 74P-A/P-B ; TAMD 75P-A | - | 21549542 ; 3827069 | N0114440 | 3825133 ; 21492771 | - | 876185 |
| TAMD 72P-A/72WJA ; TAMD 73L-A/63P-A ; TAMD 74A/A-A/A-B/C-A/C-B/L-A/L-B ; TAMD 74P-A/P-B ; TAMD 75P-A ; TAMD 71A/B/73P-A/73WJ-A ; TAMD 121C/102A/122A ; TAMD 121C/D/122C/D ; TAMD 103A-A/A-A-AUX ; TAMD 61A/62A/122A/122P-A/122P-B | - | 847741 | N0114987 | 3825133 ; 21492771 | - | 876185 |

FILTRI OLIO / NAFTA / BENZINA / ARIA VOLVO - FILTERS OIL / NAPHTHA / PETROL / AIR VOLVO

| MOTORE ENGINE | FILTRO OLIO OIL FILTER | | FILTRO CARBURANTE FUEL FILTER | |
|---------------|------------------------|-----|-------------------------------|-----|
| | REF. | OEM | REF. | OEM |

VOLVO BENZINA

| | | | | |
|--|----------|---------|----------|---------|
| 8.1 GI-J/JF/GXI-J/JF/OSI-J/JF | - | 8692305 | N0114228 | 3862228 |
| 8.1 GI-H/HF/GXI-G/GF/OSI-D/DF | N0114440 | 835440 | N0114228 | 3847644 |
| 8.2 GL | - | 3850559 | N0114228 | 3862228 |
| 8.2 GSI ; DPX415 | - | 3850559 | N0114228 | 3862228 |
| 500 A/B ; 501 A/B | N0114440 | 835440 | N0114228 | 855686 |
| 570A ; 571A ; 572A | N0114440 | 835440 | - | 855686 |
| 740 A/B | N0114440 | 835440 | - | 855686 |
| AQ 95/100/110/115/120A/130 | N0114857 | 3517857 | N0114750 | 3581078 |
| AQ 120B/140/145A/165/171 | N0114857 | 3517857 | N0114750 | 3581078 |
| AQ 120B/125A/B ; AQ131A/B/C/D ; 230A/B ; BB140A ; AQ140A ; BB145A ; AQ145A/B ; AQ151A/B/C ; 250B ; BB145A ; AQ170A/B/C | N0114857 | 3517857 | N0114078 | 3581078 |
| AQ225B/C/D/E/F | N0114440 | 835440 | N0114078 | 3581078 |
| AQ 231A/B ; BB231A | N0114440 | 835440 | N0114078 | 3581078 |
| AQ 225A/B ; AQ 260A/B ; BB 260A/B/C | N0114440 | 835440 | N0114078 | 3581078 |
| AQ 271/B/C/D ; BB261A | N0114440 | 835440 | N0114686 | 855686 |
| AQ 280A ; AQ 290A | N0114440 | 835440 | N0114078 | 3581078 |
| AQ 311A/B | N0114440 | 835440 | N0114686 | 855686 |
| BB 115A/B/C ; AQ 115A/B ; AQ 130A/B/C/D | N0114857 | 3517857 | N0114078 | 3581078 |
| BB 225A/B/C | N0114440 | 835440 | N0114686 | 855686 |
| 3.0 GLP-C/D/E/J | N0114440 | 835440 | N0114078 | 3581078 |
| 3.0 GXI-J/XIC-J | N0114440 | 835440 | - | - |
| 4,3 GL-J/JF ; GXI-J/JF ; OSI-J/JF | - | 8692305 | - | 3862228 |
| 4.3 GXI-G/GF/OSI-G/GF | N0114440 | 835440 | - | 3847644 |
| 4.3 GL-A/GL-B/GL-C/GL-D ; AQ175A ; AQ205A ; 430A/B ; 431A/B ; 432A ; 434A | N0114750 | 841750 | N0114228 | 3862228 |
| 5.0 GXI-G/GXI-GF/OSI-G/OSI-GF | N0114440 | 835440 | N0114228 | 3862228 |
| 5.7 GI300-J/JF ; 5.7 OSI-J/JF ; 5.7 GXI-J/JF ; 5.7 OSXI-J/JF | - | 8692305 | N0114686 | 3862228 |
| 5.7 GI-F/GI-FF/GXI-G/GXI-GF ; 5.7 OSI-E/OSI-EF | N0114440 | 835440 | N0114686 | 3862228 |
| 7.4 GI/GSI ; DPX385 | - | 3850559 | N0114228 | 3862228 |
| 7.4 GL | - | 3850559 | N0114228 | 3862228 |

FILTRI OLIO / BENZINA / ARIA YANMAR - FILTERS OIL / PETROL / AIR YANMAR

| MOTORE ENGINE | FILTRO OLIO OIL FILTER | | FILTRO CARBURANTE FUEL FILTER | | FILTRO ARIA AIR FILTER | |
|-----------------------------------|------------------------|--------------------|-------------------------------|--------------|------------------------|--------------|
| | REF. | OEM | REF. | OEM | REF. | OEM |
| 1 GM / GM10 | N0114440 | 119305-35151 | N0114500 | 104500-55710 | - | - |
| 2GM20 | N0114440 | 119305-35151 | N0114500 | 104500-55710 | - | 128270-12540 |
| 2GM20F | N0114440 | 119305-35151 | N0114500 | 104500-55710 | - | 128270-12540 |
| 2GM20YEU/FYEU | N0114440 | 119305-35151 | N0114500 | 104500-55710 | - | 128270-12540 |
| QM20/30 | - | 124085-35111-35112 | N0114500 | 104500-55710 | - | - |
| 3GM30 | N0114151 | 119305-35151 | N0114500 | 104500-55710 | - | 128270-12540 |
| 3GM30YEU | N0114151 | 119305-35151 | N0114500 | 104500-55710 | - | 128270-12540 |
| 3GM30F | N0114151 | 119305-35151 | N0114500 | 104500-55710 | - | 128270-12540 |
| 3GM30FYEU | N0114151 | 119305-35151 | N0114500 | 104500-55710 | - | 128270-12540 |
| 3JH2E | N0114151 | 119305-35151 | N0114500 | 104500-55710 | - | - |
| 3JH2TE | N0114151 | 119305-35151 | N0114703 | 129470-55703 | - | 129470-12330 |
| 4JH SM3 BG3 | N0114440 | 129150-35150 | N0114703 | 129470-55703 | - | - |
| 4JHE/2E/2TE; 4JH2HTE; 2DTE-4JHDTE | N0114153 | 129150-35153 | N0114703 | 129470-55703 | - | 129470-12330 |
| 4JH2UTE | N0114153 | 129150-35153 | - | 129574-55711 | - | 129470-12330 |
| 3JH3E/EYEU | N0114151 | 119305-35150/51 | N0114703 | 129470-55703 | - | - |
| 4JH3E | N0114153 | 129150-35153 | N0114703 | 129470-55703 | - | - |
| 4JH3TE; 4JH3HTE/DTE | N0114153 | 129150-35153 | - | 129574-55711 | - | 129470-12330 |
| 4LHDTE/STE | - | 127695-35150 | N0114650 | 41650-502320 | - | XN199611 |
| 4LHADTE; 4LHASTE | - | 127695-35150 | N0114650 | 41650-502320 | - | 119195-18880 |
| 6CX530 | - | 127695-35150 | N0114703 | 127677-55136 | - | 127692-18880 |
| 3JH4E/5E | N0114153 | 11935-35150/51 | - | 129470-55703 | - | - |
| 4JH5E/4AE | N0114153 | 129150-35153 | - | 119802-55801 | - | - |
| 4JH4E | N0114153 | 129150-35153 | N0114703 | 129470-55703 | - | - |
| 4JH4TE-HTE | N0114153 | 129150-35153 | - | 129757-55711 | - | - |
| 3YN30/N20/N15 | N0114151 | 119305-35150/51 | N0114500 | 104500-55710 | - | 128270-12540 |

FILTRI ENTROBORDO | INBOARD FILTERS

Filtro carburante Yanmar Yanmar fuel filter

| Articolo - Item | €/pc. | OEM |
|-----------------|-------|-------------|
| N 01 14 500 | | 10450055710 |

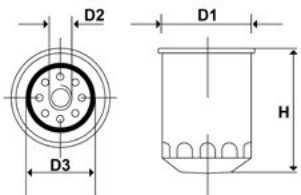

| | |
|----|----|
| H | 70 |
| D1 | 35 |
| D2 | 11 |
| D3 | - |



Filtro carburante Yanmar Yanmar fuel filter

| Articolo - Item | €/pc. | OEM |
|-----------------|-------|--------------|
| N 01 14 650 | | 41650-502320 |

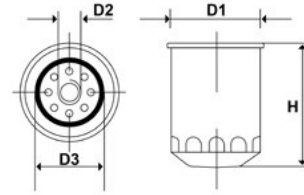

| | |
|----|----|
| H | 95 |
| D1 | 72 |
| D2 | 12 |
| D3 | 22 |



Filtro carburante Yanmar Yanmar fuel filter

| Articolo - Item | €/pc. | OEM |
|-----------------|-------|-------------|
| N 01 14 703 | | 12947055703 |

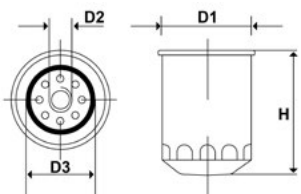

| | |
|----|----|
| H | 78 |
| D1 | 84 |
| D2 | - |
| D3 | 61 |



Filtro olio Yanmar Yanmar oil filter

| Articolo - Item | €/pc. | OEM |
|-----------------|-------|----------------|
| N 01 14 151 | | 11930535150/51 |

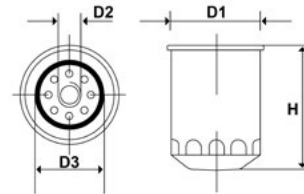

| | |
|----|---------|
| H | 75 |
| D1 | 80 |
| D2 | M20x1,5 |
| D3 | 61 |



Filtro olio Yanmar Yanmar oil filter

| Articolo - Item | €/pc. | OEM |
|-----------------|-------|--------------------|
| N 01 14 153 | | 129150-35153 (Ø79) |

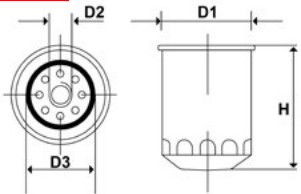

| | |
|----|---------|
| H | 78 |
| D1 | 79 |
| D2 | M20x1,5 |
| D3 | 62 |



Filtro olio Yanmar Yanmar oil filter

| Articolo - Item | €/pc. | OEM |
|-----------------|-------|--------------------|
| N 01 14 089 | | 129150-35150 (Ø89) |

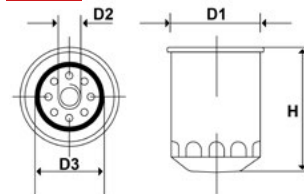

| | |
|----|---------|
| H | 78 |
| D1 | 89 |
| D2 | M20x1,5 |
| D3 | 64 |



Filtro benzina motori Volvo Penta benzina

Fuel filter for Volvo Penta fuel engines

| Articolo - Item | €/pc. | OEM |
|-----------------|-------|---------|
| N 01 14 228 | | 3862228 |



NEW

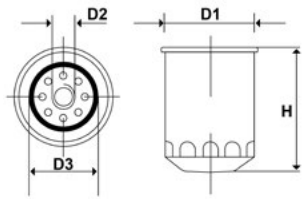

| | |
|----|----|
| H | 86 |
| D1 | 77 |
| D2 | - |
| D3 | 72 |

Filtro benzina motori benzina

Fuel filter for fuel engines

| Articolo - Item | €/pc. | Motore-Engine | OEM |
|-----------------|-------|------------------|---------------------------|
| N 01 14 686 | | VOLVO | 855686 |
| | | CRUSADER | 98041 |
| | | MERCURISER | 32716 35-60494-1 35807172 |
| | | YAMAHA V8 5,5 LT | ABA-FUEL-IL-TR |
| | | YAMAHA V6 4,3 LT | ABA-FUEL-IL-TR |



NEW

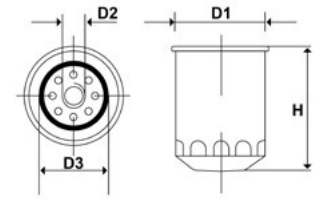

| | |
|----|-------|
| H | 104 |
| D1 | 95 |
| D2 | - |
| D3 | 90-73 |

Filtro olio motori Volvo Penta diesel

Oil filter for Volvo Penta diesel engines

| Articolo - Item | €/pc. | OEM |
|-----------------|-------|---------|
| N 01 14 528 | | 3840525 |



NEW

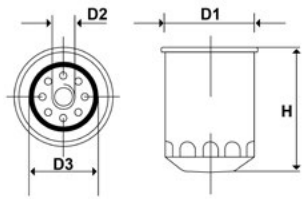

| | |
|----|-------------|
| H | 89 |
| D1 | 78 |
| D2 | 3/4"-16 UNF |
| D3 | 71,5 |

Filtro olio motori benzina

Oil filter for fuel engines

| Articolo - Item | €/pc. | Motore-Engine | OEM |
|-----------------|-------|---------------|-----------------------------|
| N 01 14 750 | | VOLVO | 835440 |
| | | MERCURISER | 35-802884Q 35-883702Q 41815 |
| | | GM | Motore GM V-6 |
| | | CHRYSLER | L319 |
| | | OMC | 173834-502903 |



NEW

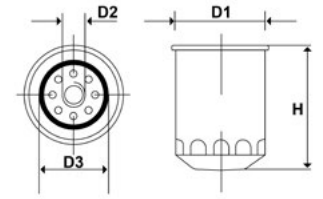

| | |
|----|-----|
| H | 121 |
| D1 | 76 |
| D2 | - |
| D3 | 71 |

Filtro olio motori benzina

Oil filter for fuel engines

| Articolo - Item | €/pc. | Motore-Engine | OEM |
|-----------------|-------|------------------|---|
| N 01 14 440 | | VOLVO | 835440 |
| | | CRUSADER | 201104 |
| | | MERCURISER | 32716 14957 52731 54111 |
| | | OMC 8 CIL | 35866340Q03/K01 35-802885Q |
| | | YAMAHA V8 5,5 LT | Motore GM Filtro corto 173232 502901 |



NEW

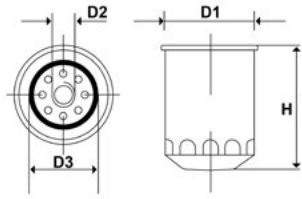

| | |
|----|-----|
| H | 105 |
| D1 | 94 |
| D2 | - |
| D3 | 87 |

Filtro olio motori Volvo Penta diesel

Oil filter for Volvo Penta diesel engines

| Articolo - Item | €/pc. | OEM |
|-----------------|-------|-------------------|
| N 01 14 337 | | 834337 ; 22057107 |



NEW

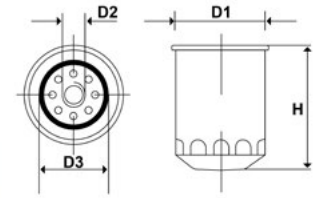

| | |
|----|-------------|
| H | 55 |
| D1 | 76 |
| D2 | 3/4"-16 UNF |
| D3 | 72 |

FILTRI ENTROBORDO | INBOARD FILTERS

Filtro olio motori Volvo Penta diesel

Oil filter for Volvo Penta diesel engines

| Articolo - Item | €/pc. | OEM |
|-----------------|-------|-------------------|
| N 01 14 621 | | 3581621; 21549544 |

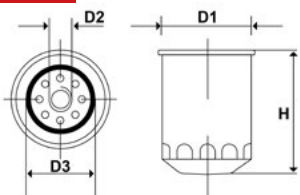

| | |
|----|-------------|
| H | 100 |
| D1 | 80 |
| D2 | 3/4"-16 UNF |
| D3 | 65 |



Filtro olio motori benzina e diesel

Oil filter for fuel & diesel engines

| Articolo - Item | €/pc. | Motore-Engine | OEM |
|-----------------|-------|--------------------------|---------|
| N 01 14 857 | | VOLVO PENTA BENZINA FUEL | 3517857 |
| | | VOLVO PENTA DIESEL | 3517857 |
| | | YAMAHA V6 4.3 LT | - |

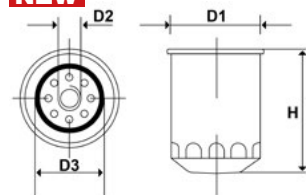

| | |
|----|-------------|
| H | 86 |
| D1 | 93 |
| D2 | 3/4"-16 UNF |
| D3 | 71 |



Filtro olio motori Volvo Penta diesel

Oil filter for Volvo Penta diesel engines

| Articolo - Item | €/pc. | OEM |
|-----------------|-------|--------|
| N 01 14 034 | | 471034 |

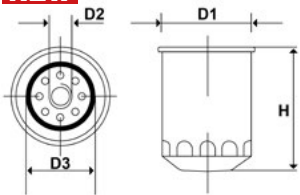

| | |
|----|-----------|
| H | 132 |
| D1 | 104 |
| D2 | 1"-12 UNF |
| D3 | 71 |



Filtro olio motori Volvo Penta diesel

Oil filter for Volvo Penta diesel engines

| Articolo - Item | €/pc. | OEM |
|-----------------|-------|--------------------|
| N 01 14 848 | | 3582732 ; 22030848 |

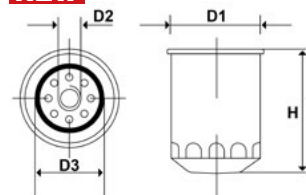

| | |
|----|-----------|
| H | 215 |
| D1 | 95 |
| D2 | 1"-12 UNF |
| D3 | 72 |



Filtro olio motori Volvo Penta diesel

Oil filter for Volvo Penta diesel engines

| Articolo - Item | €/pc. | OEM |
|-----------------|-------|---------|
| N 01 14 733 | | 3582733 |

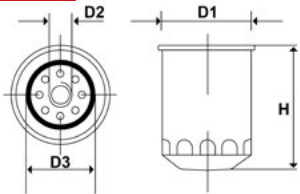

| | |
|----|-------------|
| H | 215 |
| D1 | 95 |
| D2 | 3/4"-16 UNF |
| D3 | 72 |



Filtro olio motori Volvo Penta diesel

Oil filter for Volvo Penta diesel engines

| Articolo - Item | €/pc. | OEM |
|-----------------|-------|------------------|
| N 01 14 974 | | 4785974 ; 423135 |

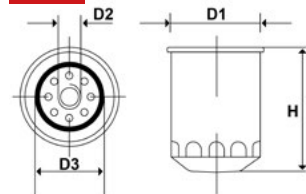

| | |
|----|-----------|
| H | 170 |
| D1 | 93 |
| D2 | 1"-12 UNF |
| D3 | 73 |



Filtro nafta motori Volvo Penta diesel

Naphtha filter for Volvo Penta diesel engines

| Articolo - Item | €/pc. | OEM |
|-----------------|-------|--------------------|
| N 01 14 443 | | 3583443 ; 21718912 |



NEW

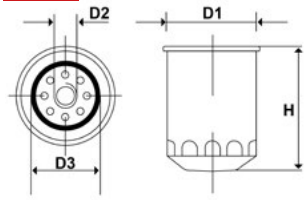

| | |
|----|-----|
| H | 140 |
| D1 | 94 |
| D2 | M16 |
| D3 | 74 |



Filtro nafta motori Volvo Penta diesel

Naphtha filter for Volvo Penta diesel engines

| Articolo - Item | €/pc. | OEM |
|-----------------|-------|--------|
| N 01 14 777 | | 861477 |



NEW

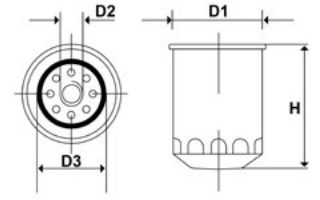

| | |
|----|-------------|
| H | 90 |
| D1 | 80 |
| D2 | 3/4"-16 UNF |
| D3 | 62 |



Filtro nafta motori Volvo Penta diesel

Naphtha filter for Volvo Penta diesel engines

| Articolo - Item | €/pc. | OEM |
|-----------------|-------|----------|
| N 01 14 740 | | 21624740 |



NEW

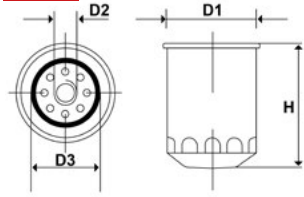

| | |
|----|-----|
| H | 155 |
| D1 | 85 |
| D2 | - |
| D3 | 77 |



Filtro nafta motori Volvo Penta diesel

Naphtha filter for Volvo Penta diesel engines

| Articolo - Item | €/pc. | OEM |
|-----------------|-------|-------------------------|
| N 01 14 987 | | 3825133 21492771 466987 |



NEW

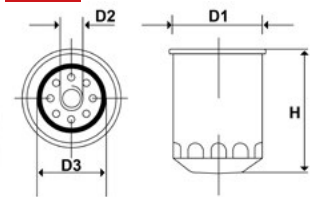

| | |
|----|---------|
| H | 120 |
| D1 | 77 |
| D2 | M16x1,5 |
| D3 | 72 |



Filtro nafta motori Volvo Penta diesel

Naphtha filter for Volvo Penta diesel engines

| Articolo - Item | €/pc. | OEM |
|-----------------|-------|---------|
| N 01 14 078 | | 3581078 |



NEW

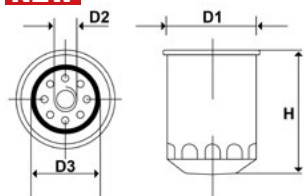

| | |
|----|----|
| H | 71 |
| D1 | 85 |
| D2 | 19 |
| D3 | - |



FILTRI FUORIBORDO 4 TEMPI | OUTBOARD FILTERS 4 STROKES

Filtro olio fuoribordo Outboard engine oil filter

| Articolo - Item | €/pc. | Motore-Engine | OEM | HP |
|-----------------|-------|---------------|-------------------|------|
| N 01 14 615 | | HONDA | 15400-PFB-014/004 | 8/60 |
| | | TOHATSU | 3R-07615-0 | - |
| | | MERCURY | 35-822626Q1,Q03 | 8/30 |

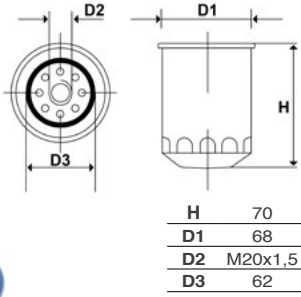

Filtro olio fuoribordo Outboard engine oil filter

| Articolo - Item | €/pc. | Motore-Engine | OEM | HP |
|-----------------|-------|---------------|--|--------|
| N 01 14 400 | | MERCURY | EFI 40/60 - 35-8M0065103 (35-822626Q04) | 40/60 |
| | | HONDA | 15400-PLM-A01PE | 75/225 |

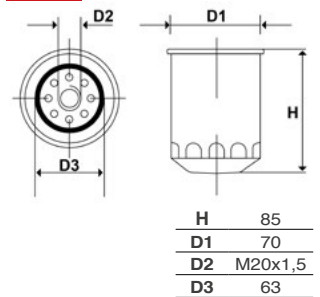

Filtro olio fuoribordo Outboard engine oil filter

| Articolo - Item | €/pc. | Motore-Engine | OEM | HP |
|-----------------|-------|---------------|-----------------------------|---------|
| N 01 14 205 | | YAMAHA | 5GH-13440-20 | 9,9/100 |
| | | HONDA | 15400-PFB-007 15400-ZW4-003 | 25/50 |

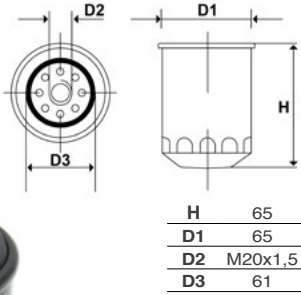

Filtro olio fuoribordo Outboard engine oil filter

| Articolo - Item | €/pc. | Motore-Engine | OEM | HP |
|-----------------|-------|---------------|-----------------|---------|
| N 01 14 169 | | MERCURY | 35-822626-Q15 | 225 |
| | | YAMAHA | 69J-13440-00-00 | 150/250 |

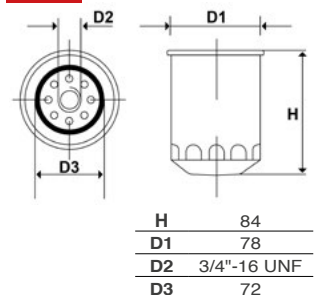

Filtro olio fuoribordo Outboard engine oil filter

| Articolo - Item | €/pc. | Motore-Engine | OEM | HP |
|-----------------|-------|---------------|--------------|---------|
| N 01 14 005 | | YAMAHA | 5GH-13440-00 | 9,9/115 |
| | | SELVA | - | 9,9/115 |

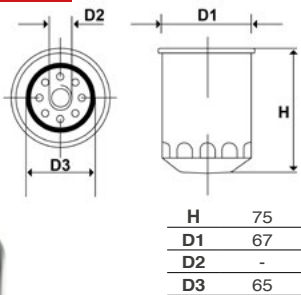

Filtro carburante fuoribordo Fuel filter for outboard engines

Adatto per Mercury VERADO 4/6 cilindri (Orig. 35-8M0020349-35-893318502) Suitable for Mercury VERADO 4/6 cyl. (Orig. 35-8M0020349-35-893318502)

| Articolo - Item | €/pc. | Fillettatura Threading Ø mm. | Corpo-Body Ø mm. | H mm. |
|-----------------|-------|------------------------------|------------------|-------|
| N 01 14 349 | | 45,5 | 35,5 | 126 |



Chiave di sicurezza per motore fuoribordo con laccio estraibile Safety stop key with spiral string

Con laccio estraibile e moschettone.

Equipped with spiral string and snap hook.

| Articolo - Item | €/pc. | Per motori-For engines | kg. |
|-----------------|-------|------------------------|-------|
| L 53 62 562 | | New Suzuki | 0,030 |
| L 53 62 563 | | Mercury | 0,030 |
| L 53 62 557 | | Tohatsu | 0,030 |
| L 53 62 560 | | New Honda | 0,030 |
| L 53 62 558 | | OMC-Johnson Evinrude | 0,030 |
| L 53 62 561 | | Yamaha Ø 9 mm. | 0,030 |
| L 53 62 559 | | New OMC | 0,030 |



L5362563



L5362557



L5362560



L5362558



L5362562



L5362561



L5362559

Kit chiavetta di sicurezza per motori fuoribordo

Completo di laccio estensibile, moschettone e 11 chiavette.

Safety stop key kit for outboard engines

Equipped with spiral string, snap hook and 11 keys.

| Articolo - Item | €/Kit | Per motori-For engines |
|-----------------|-------|--|
| L 53 10 284 | | Johnson / Evinrude (old and new model) / Yamaha / Honda (old and new model) / Mercury / Suzuki (old and new model) / Tohatsu (2 and 4 strokes), Kawasaki |



Stacco automatico regolamentare per accensione

Fabbricato completamente in ottone cromato, con cappuccio posteriore e anteriore a tenuta stagna.

Ignition cut-off device (complying with regulations)

Manufactured in chromed brass, with front and back watertight cover.

| Articolo - Item | €/pc. | Circuit | Utilizzo-Use |
|-----------------|-------|---------|---|
| L 06 00 080 | | Open | Togliere il cappuccio per aprire il circuito Pull the cap to open the circuit |
| L 06 00 130 | | Close | Togliere il cappuccio grigio per chiudere il circuito (per Selva) Pull the grey cap to close the circuit (fit for Selva) |

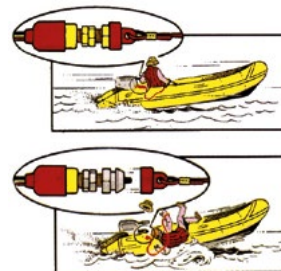

Stacco automatico regolamentare per accensione

Con sistema a clip sfilabile. Universale, può sia aprire che chiudere il circuito a seconda dei terminali che vengono collegati.

Ignition cut-off device (complying with regulations)

With slip-off clip system, universal size, it can open and close the circuit depending on the terminals that are connected.

| Articolo - Item | €/pc. | Mod. |
|-----------------|-------|--|
| N 01 10 285 | | Completo di chiavetta di sicurezza e galleggiante With safety key and float |



CANDELE | CANDLES

Candele NGK NGK Candles

| Articolo - Item | €/pc. | Mod. | Articolo - Item | €/pc. | Mod. |
|-----------------|-------|-----------|-----------------|-------|----------|
| E 10 06 000 | | B6HS | E 10 07 410 | | BR7HS-10 |
| E 10 07 000 | | B7HS | E 10 08 400 | | BR8HS |
| E 10 07 010 | | B7HS-10 | E 10 08 410 | | BR8HS-10 |
| E 10 08 000 | | B8HS | E 10 09 410 | | BR9HS-10 |
| E 10 08 010 | | B8HS-10 | E 10 08 450 | | BU8H |
| E 10 09 010 | | B9HS-10 | E 10 00 700 | | BUHW |
| E 10 06 002 | | BP6ES | E 10 02 708 | | BUHW-2 |
| E 10 06 200 | | BP6HS | E 10 08 500 | | BUZ8H |
| E 10 08 100 | | BP8HN-10 | E 10 00 500 | | BUZHW |
| E 10 05 600 | | BPR5EFS | E 10 06 009 | | CPR6EA-9 |
| E 10 06 614 | | BPR6EFS | E 10 05 009 | | CR5EH-9 |
| E 10 07 200 | | BPR7HS-10 | E 10 06 601 | | CR6HS |
| E 10 08 310 | | BPZ8HN-10 | E 10 06 609 | | DPR6EA-9 |
| E 10 06 615 | | BR6FS | E 10 06 900 | | DPR6EB-9 |
| E 10 06 013 | | BR6ES | E 10 07 900 | | DPR7EA-9 |
| E 10 07 067 | | BR7HS | - | | - |



NEW



ANODI | ANODES

**Anodi per assi ed eliche
Radice**

Rondella in acciaio inox.

Axis line Radice anodes

Washer in stainless steel.

| Articolo - Item | €/pc. | Art. POLIPODIO | Mod. | A Ø mm. | B Ø mm. | K mm. |
|-----------------|-------|----------------|------|------------|------------|----------|
| L 81 15 016 | | RA003 | Ø 25 | 38 | 17 | 5,8 |
| L 81 15 020 | | RA006 | Ø 30 | 46 | 20 | 7,7 |
| L 81 15 024 | | RA009 | Ø 35 | 51 | 24 | 9,6 |
| L 81 15 025 | | RA012 | Ø 40 | 54 | 25 | 9,8 |
| L 81 15 033 | | RA015 | Ø 45 | 66 | 33 | 12 |
| L 81 15 037 | | RA018 | Ø 50 | 76 | 36 | 14 |
| L 81 15 040 | | RA021 | Ø 55 | 81 | 40 | 15,5 |
| L 81 15 045 | | RA024 | Ø 60 | 90 | 46 | 16 |

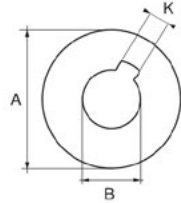

**Anodi per assi ed eliche
Radice**

Ricambio solo anodo.

Axis line Radice anodes

Spare anod only.

| Articolo - Item | €/pc. | Art. POLIPODIO | Mod. | A Ø mm. | B Ø mm. | E mm. | H mm. | Mat. |
|-----------------|-------|----------------|---------------|------------|------------|----------|----------|------|
| L 81 10 625 | | RA030 | RA-1E Ø 22-25 | 32 | 22 | 37 | 39 | ZN |
| L 81 10 630 | | RA031 | RA-2E Ø 30 | 41 | 27 | 43 | 57 | ZN |
| L 81 10 635 | | RA032 | RA-2GE Ø 35 | 44 | 32 | 48 | 58 | ZN |
| L 81 10 640 | | RA033 | RA-3E Ø 40 | 50 | 36 | 53 | 65 | ZN |
| L 81 10 645 | | RA034 | RA-4E Ø 45 | 59 | 41 | 58 | 73 | ZN |
| L 81 10 650 | | RA035 | RA-5E Ø 50 | 72 | 46 | 73 | 83 | ZN |
| L 81 10 655 | | RA060 | RA-5GE Ø 55 | 72 | 50 | 75 | 83 | ZN |
| L 81 10 660 | | RA036 | RA-6E Ø 60 | 82 | 55 | 85 | 95 | ZN |

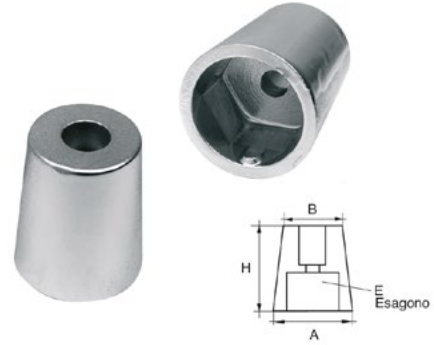

**Anodo per assi ed eliche
Riva**

Ogive in bronzo complete di anodo in zinco e vite CE.

Axis line Riva anode

Bronze ogive complete with zinc anode and CE screw.

| Articolo - Item | €/pc. | Art. POLIPODIO | Mod. | A Ø mm. | H mm. | F mm. | Mat. |
|-----------------|-------|----------------|-----------|------------|----------|----------|------|
| L 81 13 140 | | RI008 | RI-5 Ø 40 | 52 | 88 | 26x2 | ZN |

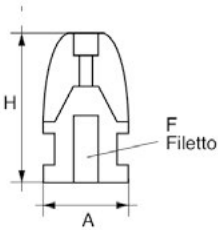

**Anodi per assi ed eliche
Riva**

Ricambio solo anodo.

Axis line Riva anodes

Spare anod only.

| Articolo - Item | €/pc. | Art. POLIPODIO | Mod. | A Ø mm. | H mm. | Mat. |
|-----------------|-------|----------------|--------------|------------|----------|------|
| L 81 13 125 | | RI006 | RI-1/2/3/W/X | 38 | 38 | ZN |
| L 81 13 135 | | RI010 | RI 4/5/X | 52 | 59 | ZN |



**Anodo per assi ed eliche
Flex-Fold**

| Articolo - Item | €/pc. | Art. POLIPODIO | Materiale Material |
|-----------------|-------|----------------|--------------------|
| L 81 19 559 | | OG058 | ZN |

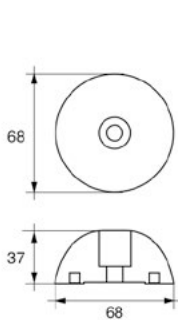

**Anodi per assi ed eliche
Ferretti**

| Articolo - Item | €/pc. | Art. POLIPODIO | Mod. | A Ø mm. | B Ø mm. | C mm. | H mm. | Mat. |
|-----------------|-------|----------------|------------|------------|------------|----------|----------|------|
| L 81 14 040 | | OG006 | F-RA-3M/1 | 50 | 41,5 | 37 | 65 | ZN |
| L 81 14 045 | | OG007 | F-RA-3M/2 | 50 | 41,5 | 35 | 65 | ZN |
| L 81 14 050 | | OG007A | F-RA-3M/2A | 61 | 48 | 40 | 75 | ZN |
| L 81 14 055 | | OG008 | F-RA-3M/3 | 58,5 | 47 | 40 | 90 | ZN |
| L 81 14 075 | | OG008A | F-RA-3M/3A | 74 | 61 | 55 | 95 | ZN |

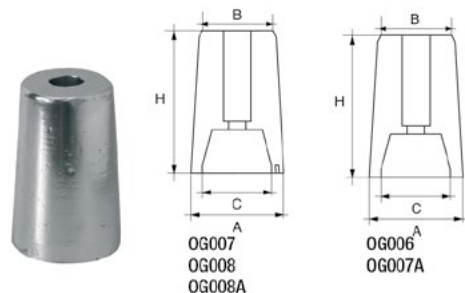

Anodo per assi ed eliche
Ferretti

Axis line Ferretti anode

| Articolo - Item | €/pc. | Art. POLIPODIO | Mod. | A Ø mm. | B Ø mm. | C mm. | H mm. | Mat. |
|-----------------|-------|-------------------|-----------|------------|------------|----------|----------|------|
| L 81 14 125 | | OG030 | F-RA-3M/4 | 155 | 116 | 132 | 126 | ZN |

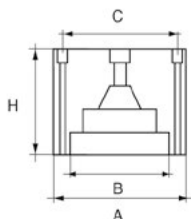

Anodi per assi ed eliche
Reggiani

Axis line Reggiani anodes

| Articolo - Item | €/pc. | Art. POLIPODIO | Mod. | A Ø mm. | B mm. | H mm. | Mat. |
|-----------------|-------|-------------------|--------|------------|----------|----------|------|
| L 81 10 025 | | OG017 | F-RG-2 | 34 | 20 | 34 | ZN |
| L 81 10 030 | | OG018 | F-RG-3 | 43 | 25 | 50 | ZN |
| L 81 10 035 | | OG019 | F-RG-4 | 48 | 28 | 55 | ZN |
| L 81 10 040 | | OG020 | F-RG-5 | 54 | 34 | 54 | ZN |
| L 81 10 045 | | OG021 | F-RG-6 | 64 | 40 | 64 | ZN |
| L 81 10 050 | | OG022 | F-RG-7 | 74 | 45 | 74 | ZN |
| L 81 10 055 | | OG047 | F-RG-8 | 78 | 49 | 75 | ZN |
| L 81 10 060 | | OG056 | F-RG-9 | 88 | 55 | 85 | ZN |

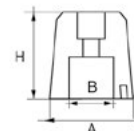
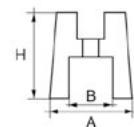

Anodi per assi ed eliche
Solé

Axis line Solé anodes

| Articolo - Item | €/pc. | Art. POLIPODIO | Mod. | A Ø mm. | B mm. | H mm. | Mat. |
|-----------------|-------|-------------------|--------|------------|----------|----------|------|
| L 81 10 125 | | OG069 | F-SO-1 | 32 | 24 | 39 | ZN |
| L 81 10 130 | | OG070 | F-SO-2 | 37 | 26 | 46 | ZN |
| L 81 10 135 | | OG071 | F-SO-3 | 47 | 36 | 60 | ZN |
| L 81 10 140 | | OG072 | F-SO-4 | 52 | 41 | 70 | ZN |

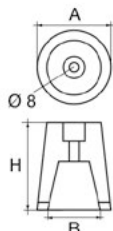

Anodo per assi ed eliche
Max Prop

Axis line Max Prop anode

| Articolo - Item | €/pc. | Art. POLIPODIO | Mod. | Materiale Material |
|-----------------|-------|-------------------|---------|-----------------------|
| L 81 19 236 | | OG062 | F-MAX-9 | ZN |

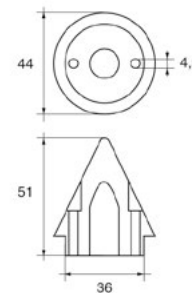

Anodi per assi ed eliche
J Prop

Axis line J Prop anodes

| Articolo - Item | €/pc. | Art. POLIPODIO | A Ø mm. | B mm. | H mm. | Materiale Material |
|-----------------|-------|-------------------|------------|----------|----------|-----------------------|
| L 81 19 134 | | OG041 | 80 | 10 | 33 | ZN |
| L 81 19 139 | | OG042 | 60 | 8,5 | 27 | ZN |
| L 81 19 149 | | OG042G | 90 | 10 | 37 | ZN |

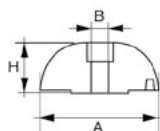

Anodi per assi ed eliche
Side Power

Axis line Side Power anodes

| Articolo - Item | €/pc. | Art. POLIPODIO | Mod. | Materiale Material |
|-----------------|-------|-------------------|-----------------------|-----------------------|
| L 81 25 570 | | OG034B | Original code: 201180 | ZN |

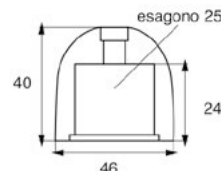

ANODI | ANODES

Anodi per assi ed eliche Axis line Sleipner anodes Sleipner

| Articolo - Item | €/pc. | Art. POLIPODIO | Mod. | A Ø mm. | B mm. | H mm. | E mm. | Mat. |
|-----------------|-------|----------------|--------------|---------|-------|-------|-------|------|
| L 81 25 581 | | OG038 | O.C.: 101180 | 42 | - | 36 | 25 | ZN |

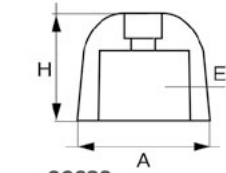

OG038

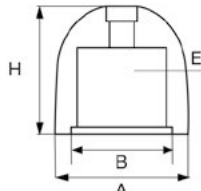

OG038B

Anodo per assi ed eliche Axis line Sleipner anode Sleipner

| Articolo - Item | €/pc. | Art. POLIPODIO | Mod. | Mat. |
|-----------------|-------|----------------|-------------------------------------|------|
| L 81 25 582 | | OG039 | Original code: 71190 ELICHE 75T-90T | ZN |

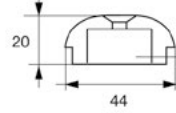
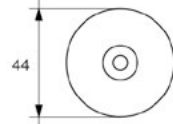

Esagono 19



Anodo per assi ed eliche Axis line Sleipner anode Sleipner

| Articolo - Item | €/pc. | Art. POLIPODIO | Mod. | Mat. |
|-----------------|-------|----------------|----------------------|------|
| L 81 25 580 | | OG040 | Original code: 61180 | ZN |

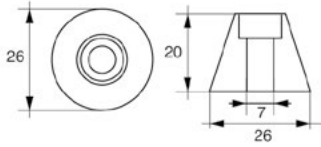

Anodo per assi ed eliche Axis line Vetus anode Vetus

| Articolo - Item | €/pc. | Art. POLIPODIO | Mod. | Mat. |
|-----------------|-------|----------------|------------------------------|------|
| L 81 25 511 | | OG027 | F-BC-2 Original code: BP195E | ZN |

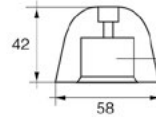
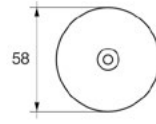

Esagono 24,5

Anodo per assi ed eliche Axis line Vetus anode Vetus

| Articolo - Item | €/pc. | Art. POLIPODIO | Mod. | Mat. |
|-----------------|-------|----------------|------------------------------|------|
| L 81 25 510 | | OG034 | F-BC-6 Original code: BP1210 | ZN |

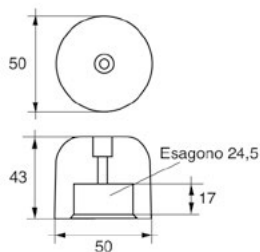

Anodi per assi ed eliche Axis line Vetus anodes Vetus

| Articolo - Item | €/pc. | Art. POLIPODIO | Mod. | A Ø mm. | B mm. | H mm. | Mat. |
|-----------------|-------|----------------|---------|---------|-------|-------|------|
| L 81 25 514 | | OG026 | F-BC-1 | 68 | 56 | 56 | ZN |
| L 81 25 515 | | OG061 | F-BC-10 | 84 | 56 | 53 | ZN |

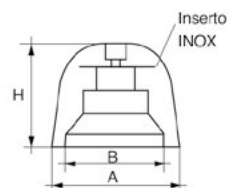

Anodo per assi ed eliche Vetus

Axis line Vetus anode

| Articolo - Item | €/pc. | Art. POLIPODIO | Mod. | Mat. |
|-----------------|-------|----------------|-----------------------------|------|
| L 81 25 518 | | OG044 | F-BC-9 Original code: BP195 | ZN |

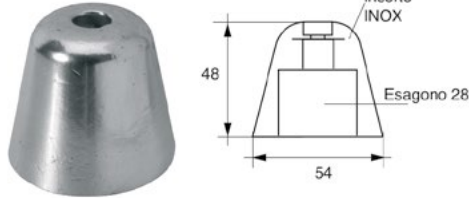

Anodo per assi ed eliche Vetus

Axis line Vetus anode

| Articolo - Item | €/pc. | Art. POLIPODIO | Mod. | Mat. |
|-----------------|-------|----------------|-----------------------------|------|
| L 81 25 540 | | OG028 | F-BC-3 Original code: BP129 | ZN |

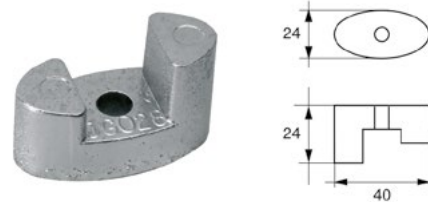

Anodo per assi ed eliche Max Power

Axis line Max Power anode

| Articolo - Item | €/pc. | Art. POLIPODIO | Materiale Material |
|-----------------|-------|----------------|--------------------|
| L 81 25 560 | | OG043 | ZN |

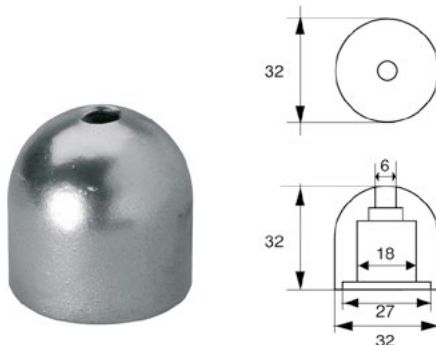

Anodi per assi ed eliche Vetus

Axis line Vetus anodes

| Articolo - Item | €/pc. | Art. POLIPODIO | Mod. | A Ø mm. | B mm. | C mm. | Mat. |
|-----------------|-------|----------------|-------------------------|---------|-------|-------|------|
| L 81 25 532 | | OG031 | F-BC-4 O.C.: BP1126 | 50 | 17 | 37 | ZN |
| L 81 25 533 | | OG033 | F-BC-5 O.C.: SET0150 | 56 | 15 | 40 | ZN |
| L 81 25 530 | | OG036 | F-BC-8 O.C.: SET0148 | 38 | 10 | 29 | ZN |

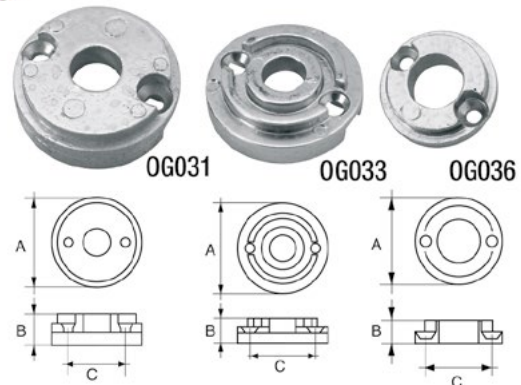

Anodi per assi ed eliche MTF

Axis line MTF anodes

| Articolo - Item | €/pc. | Art. POLIPODIO | Mod. | A Ø mm. | B Ø mm. | H mm. | Mat. |
|-----------------|-------|----------------|--------|---------|---------|-------|------|
| L 81 13 027 | | OG001 | F-MT-1 | 38 | 27 | 38 | ZN |
| L 81 13 035 | | OG002 | F-MT-2 | 53 | 35 | 50 | ZN |
| L 81 13 045 | | OG003 | F-MT-3 | 65 | 65 | 77 | ZN |

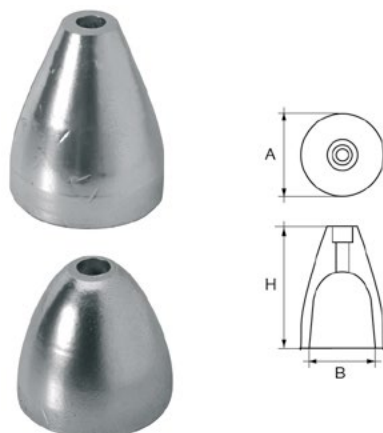

Anodi per assi ed eliche Max Prop

Axis line Max Prop anodes

| Articolo - Item | €/pc. | Art. POLIPODIO | Mod. | A Ø mm. | B Ø mm. | H mm. | Mat. |
|-----------------|-------|----------------|----------|---------|---------|-------|------|
| L 81 19 038 | | OG009 | F-MAX-01 | 67 | 38 | 40 | ZN |
| L 81 19 042 | | OG010 | F-MAX-1 | 73 | 42 | 40 | ZN |
| L 81 19 046 | | OG011 | F-MAX-2 | 84 | 46 | 60 | ZN |

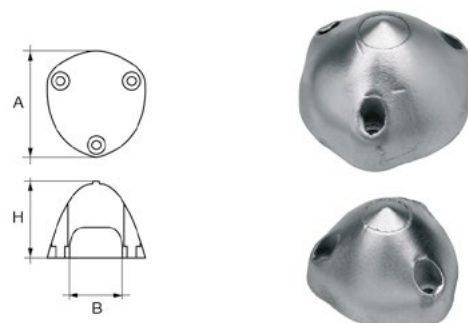

ANODI | ANODES

**Anodi per assi ed eliche
Max Prop**

| Articolo - Item | €/pc. | Art. POLIPODIO | Mod. | A Ø mm. | Materiale |
|-----------------|-------|----------------|---------|---------|-----------|
| L 81 19 442 | | OG014 | F-MAX-3 | 42 | ZN |
| L 81 19 446 | | OG015 | F-MAX-4 | 46 | ZN |

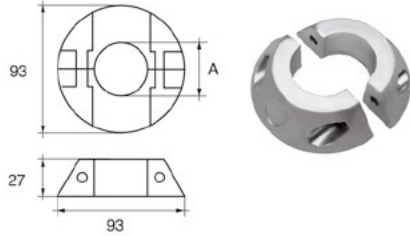

**Anodi per assi ed eliche
Max Prop**

| Articolo - Item | €/pc. | Art. POLIPODIO | A Ø mm. | B Ø mm. | C mm. | D mm. | H mm. | Mat. |
|-----------------|-------|----------------|---------|---------|-------|-------|-------|------|
| L 81 19 343 | | OG010/6F | 68 | 42 | 5 | 6 | 44 | ZN |

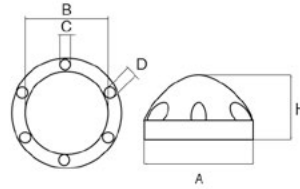

Anulari per assi

Completi di perni.

| Articolo - Item | €/pc. | Art. POLIPODIO | A Ø mm. | B Ø mm. | H mm. | Mat. |
|-----------------|-------|----------------|---------|---------|-------|------|
| L 81 06 020 | | AV002 | 20 | 60 | 15 | ZN |
| L 81 06 022 | | AV003 | 22 | 60 | 15 | ZN |
| L 81 06 025 | | AV004 | 25 | 60 | 15 | ZN |
| L 81 06 028 | | AV005 | 28 | 60 | 15 | ZN |
| L 81 06 030 | | AV006 | 30 | 60 | 15 | ZN |
| L 81 06 032 | | AV007 | 32 | 74 | 18 | ZN |
| L 81 06 035 | | AV008 | 35 | 74 | 18 | ZN |
| L 81 06 038 | | AV009 | 38 | 74 | 18 | ZN |
| L 81 06 040 | | AV010 | 40 | 74 | 18 | ZN |
| L 81 06 045 | | AV011 | 45 | 80 | 18 | ZN |
| L 81 06 050 | | AV013L | 50 | 80 | 18 | ZN |
| L 81 06 055 | | AV014 | 55 | 96 | 29 | ZN |
| L 81 06 060 | | AV015 | 60 | 120 | 29 | ZN |
| L 81 06 070 | | AV017 | 70 | 130 | 29 | ZN |
| L 81 06 080 | | AV019 | 80 | 140 | 29 | ZN |
| L 81 06 085 | | AV020 | 85 | 140 | 29 | ZN |

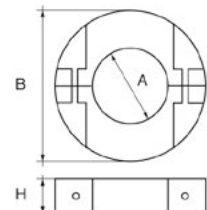
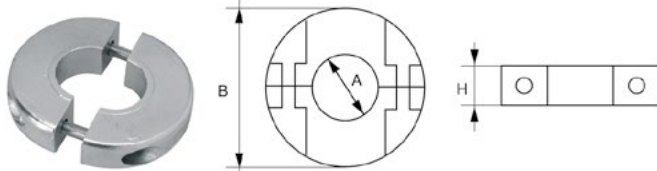

Anulari per assi

Complete with screw.

| Articolo - Item | €/pc. | Art. POLIPODIO | A Ø mm. | B Ø mm. | H mm. | Mat. |
|-----------------|-------|----------------|---------|---------|-------|------|
| L 81 00 018 | | AN001 | 18 | 50 | 47 | ZN |
| L 81 00 022 | | AN003 | 22 | 50 | 47 | ZN |
| L 81 00 025 | | AN004 | 25 | 56 | 56 | ZN |
| L 81 00 028 | | AN006 | 28 | 56 | 56 | ZN |
| L 81 00 030 | | AN008 | 30 | 56 | 56 | ZN |
| L 81 00 032 | | AN009 | 32 | 56 | 56 | ZN |
| L 81 00 035 | | AN011 | 35 | 65 | 67 | ZN |
| L 81 00 038 | | AN012 | 38 | 65 | 67 | ZN |
| L 81 00 040 | | AN013 | 40 | 81 | 83 | ZN |
| L 81 00 045 | | AN014 | 45 | - | 83 | ZN |
| L 81 00 050 | | AN016 | 50 | 81 | 83 | ZN |
| L 81 00 055 | | AN019 | 55 | 98 | 98 | ZN |
| L 81 05 070 | | AN025 | 70 | 122 | 108 | ZN |
| L 81 05 075 | | AN026 | 75 | 122 | 108 | ZN |
| L 81 05 080 | | AN027 | 80 | 122 | 108 | ZN |
| L 81 05 085 | | AN028 | 85 | 122 | 108 | ZN |

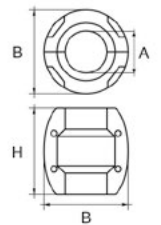
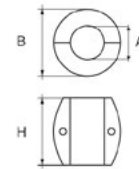
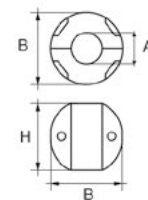

Anulare per assi

Axis line anode

| Articolo - Item | €/pc. | Art. POLIPODIO | A Ø mm. | B Ø mm. | H mm. | Mat. |
|-----------------|-------|----------------|---------|---------|-------|------|
| L 81 05 090 | | AN029 | 90 | 128 | 100 | ZN |

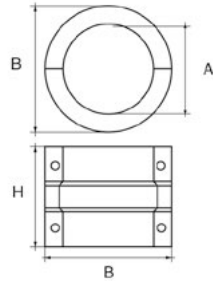

Anodo timoni e flaps

Anode for rudders & flaps

| Articolo - Item | €/pc. | Art. POLIPODIO | Mod. | Materiale Material |
|-----------------|-------|----------------|------|--------------------|
| L 81 20 206 | | NC019 | FP-1 | ZN |

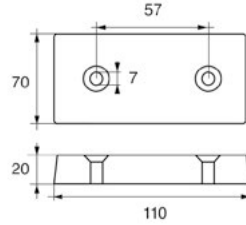

Anodo timoni e flaps

Anode for rudders & flaps

| Articolo - Item | €/pc. | Art. POLIPODIO | Mod. | Materiale Material |
|-----------------|-------|----------------|----------------|--------------------|
| L 81 20 208 | | NC021 | FX-2V Kg. 1,00 | ZN |

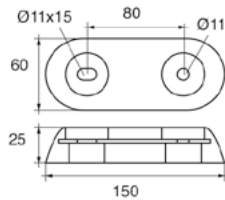

Anodo timoni e flaps

Anode for rudders & flaps

| Articolo - Item | €/pc. | Art. POLIPODIO | Mod. | A mm. | B mm. | C mm. | D mm. | Mat. |
|-----------------|-------|----------------|----------------|-------|-------|-------|-------|------|
| L 81 20 414 | | NC022 | FX-3V Kg. 2,40 | 250 | 65 | 28 | 140 | ZN |

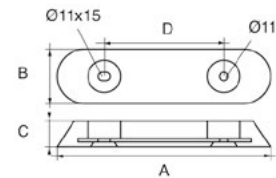

Anodo timoni e flaps

Anode for rudders & flaps

| Articolo - Item | €/pc. | Art. POLIPODIO | Mod. | Materiale Material |
|-----------------|-------|----------------|------|--------------------|
| L 81 20 205 | | NC031 | FD-1 | ZN |

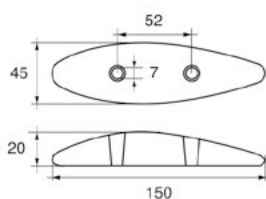

Anodo timoni e flaps

Anode for rudders & flaps

| Articolo - Item | €/pc. | Art. POLIPODIO | Mod. | Materiale Material |
|-----------------|-------|----------------|------|--------------------|
| L 81 20 203 | | NC032 | FD-2 | ZN |

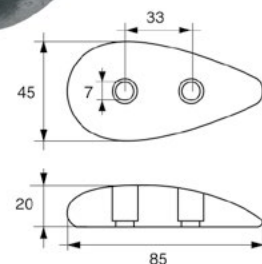

ANODI | ANODES

Anodo carene e specchi di poppa

| Articolo - Item | €/pc. | Art. POLIPODIO | A mm. | B mm. | C mm. | I mm. | Mat. |
|-----------------|-------|----------------|-------|-------|-------|-------|------|
| L 81 20 105 | | NC058 | 100 | 10 | 50 | 50 | ZN |

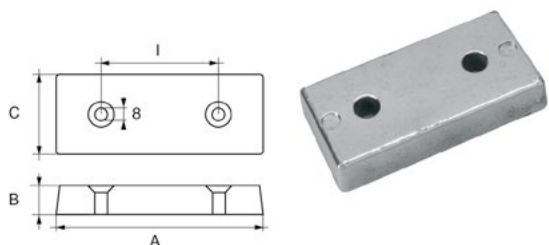

Anodi carene e specchi di poppa

| Articolo - Item | €/pc. | Art. POLIPODIO | A mm. | B mm. | C mm. | Mat. |
|-----------------|-------|----------------|-------|-------|-------|------|
| L 81 20 005 | | NC023 | 50 | 12 | 8 | ZN |
| L 81 20 007 | | NC024 | 70 | 17 | 8 | ZN |
| L 81 20 009 | | NC025 | 90 | 20 | 8 | ZN |
| L 81 20 011 | | NC026 | 110 | 25 | 10 | ZN |
| L 81 20 012 | | NC027 | 125 | 22 | 10 | ZN |
| L 81 20 014 | | NC028 | 140 | 26 | 12 | ZN |

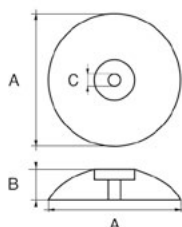

Anodi carene e specchi di poppa Fairline Sunseeker

| Articolo - Item | €/pc. | Art. POLIPODIO | Mod. | Materiale Material |
|-----------------|-------|----------------|----------------|--------------------|
| L 81 20 023 | | ZX038 | FX-7L Kg. 7,00 | ZN |

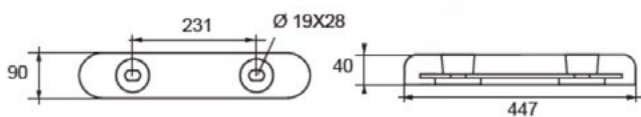

Anodi carene e specchi di poppa Fairline

| Articolo - Item | €/pc. | Art. POLIPODIO | Mod. | Materiale Material |
|-----------------|-------|----------------|-------------------|--------------------|
| L 81 20 412 | | ZX020 | FX-3D/ZN Kg. 2,40 | ZN |

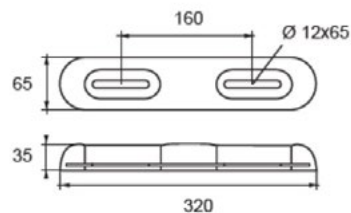

Anodi carene e specchi di poppa

| Articolo - Item | €/pc. | Art. POLIPODIO | Mod. | Materiale Material |
|-----------------|-------|----------------|----------------|--------------------|
| L 81 20 420 | | ZX010B | FX-5B Kg. 4,00 | ZN |

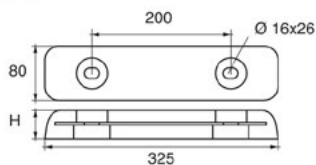

Anodi carene e specchi di poppa

| Articolo - Item | €/pc. | Art. POLIPODIO | Mod. | Materiale Material |
|-----------------|-------|----------------|---------------|--------------------|
| L 81 20 413 | | ZX011 | FX-4 Kg. 4,00 | ZN |

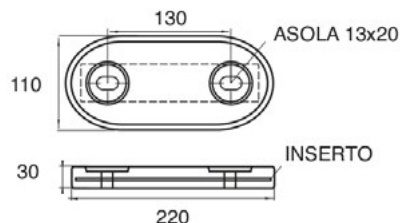

Anodo carene

Anode for hull

| Articolo - Item | €/pc. | Art. POLIPODIO | Mod. | Materiale Material |
|-----------------|-------|----------------|---------------|--------------------|
| L 81 20 320 | | ZX012 | FX-3 Kg. 3,00 | ZN |

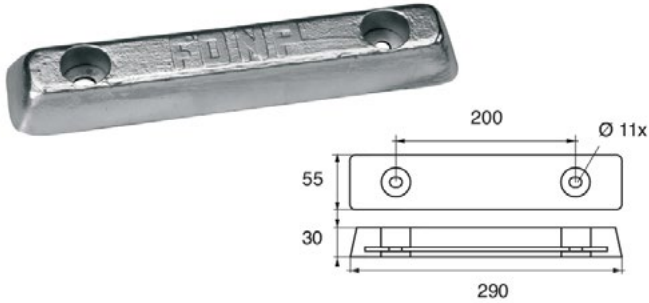

Anodo carene

Anode for hull

| Articolo - Item | €/pc. | Art. POLIPODIO | Mod. | Materiale Material |
|-----------------|-------|----------------|---------------|--------------------|
| L 81 20 257 | | ZX013 | FX-2 Kg. 1,60 | ZN |

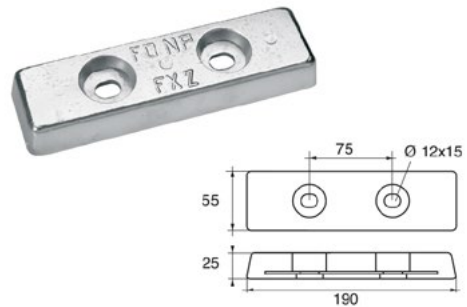

Anodi carene

Anodes for hull

| Articolo - Item | €/pc. | Art. POLIPODIO | Mod. | A mm. | B mm. | D mm. | H mm. | Mat. |
|-----------------|-------|----------------|---------------|-------|-------|-------|-------|------|
| L 81 20 304 | | ZX017 | FX-1 Kg. 1,00 | 115 | 65 | 40 | 30 | ZN |

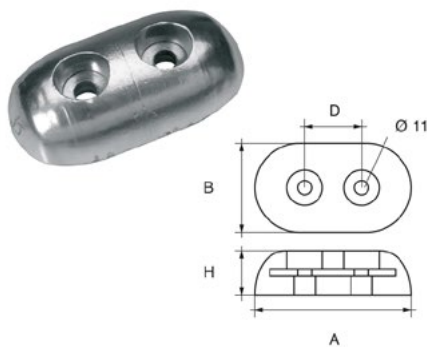

Anodo carene

Anode for hull

| Articolo - Item | €/pc. | Art. POLIPODIO | Mod. | Materiale Material |
|-----------------|-------|----------------|---------------|--------------------|
| L 81 20 258 | | NC008 | FB-3 Kg. 2,00 | ZN |

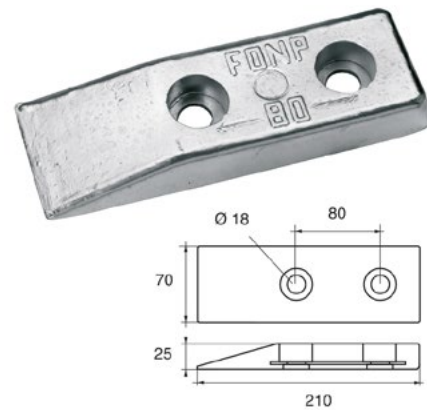

Anodi carene

Anodes for hull

| Articolo - Item | €/pc. | Art. POLIPODIO | Mod. | Mat. |
|-----------------|-------|----------------|--|------|
| L 81 20 404 | | NC045 | FC-P Kg. 4,00 Solo anodo completo di tappo filettato Only anod complete with threaded plug Guardia Costiera | ZN |

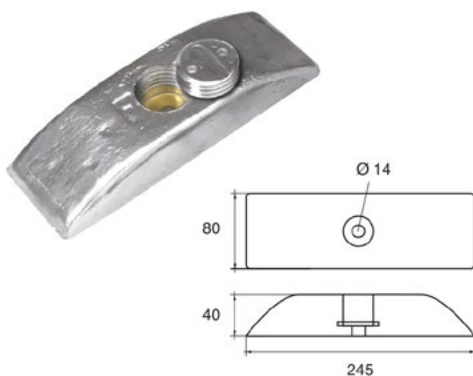

Anodo carene

Anode for hull

| Articolo - Item | €/pc. | L mm. | W mm. | H mm. |
|-----------------|-------|-------|-------|-------|
| L 81 20 107 | | 100 | 70 | 12 |



ANODI | ANODES

Anodo carene Riva

Anode for hull Riva

| Articolo - Item | €/pc. | Art. POLIPODIO | Mod. | Materiale Material |
|-----------------|-------|----------------|-----------------|--------------------|
| L 81 20 316 | | NC015 | FR-160 Kg. 2,80 | ZN |

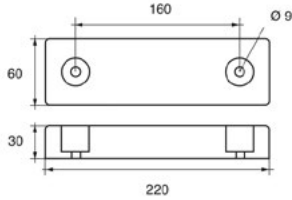

Flange tonde di poppa

Stern round flanges

| Articolo - Item | €/pc. | Ø mm. | Ø int. mm. | H mm. |
|-----------------|-------|-------|------------|-------|
| L 81 20 212 | | 125 | 50 | 38 |
| L 81 20 213 | | 135 | 50 | 74 |
| L 81 20 214 | | 140 | 55 | 35 |
| L 81 14 130 | | 140 | 50 | 30 |
| L 81 10 150 | | 100 | 40 | 40 |
| L 81 00 154 | | 120 | 50 | 35 |



Anodi a barra

Bar anodes

| Articolo - Item | €/pc. | Art. POLIPODIO | Ø mm. | L mm. | kg. | Mat. |
|-----------------|-------|----------------|-------|-------|------|------|
| L 81 04 010 | | BR001 | 10 | 400 | 0,22 | ZN |
| L 81 04 012 | | BR002 | 12 | 400 | 0,35 | ZN |
| L 81 04 014 | | BR003 | 14 | 400 | 0,50 | ZN |
| L 81 04 016 | | BR004 | 16 | 400 | 0,60 | ZN |
| L 81 04 602 | | BR006 | 20 | 400 | 0,95 | ZN |
| L 81 04 603 | | BR007 | 25 | 500 | 1,70 | ZN |
| L 81 04 604 | | BR008 | 30 | 500 | 2,50 | ZN |
| L 81 04 605 | | BR009 | 35 | 500 | 3,30 | ZN |

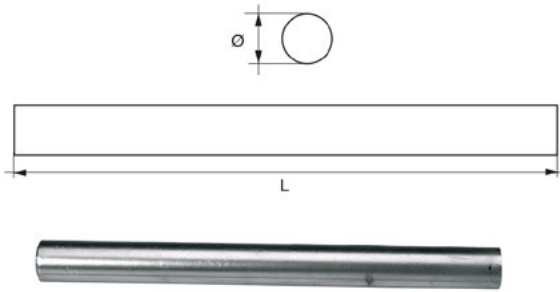

Anodi per motori Yamaha-Mariner

Anodes for engines Yamaha-Mariner

| Articolo - Item | €/pc. | Art. POLIPODIO | Mod. | Mat. |
|-----------------|-------|----------------|-----------------------------|------|
| L 81 46 305 | | YA051 | Original Code: 68V-11325-02 | ZN |

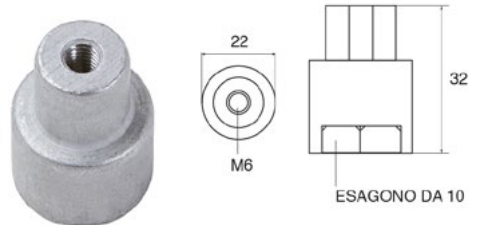

Anodi per motori Bukh

Anodes for engines Bukh

| Articolo - Item | €/pc. | Art. POLIPODIO | Mod. | Materiale Material |
|-----------------|-------|----------------|--------|--------------------|
| L 81 41 010 | | BU001 | F-VP/B | ZN |

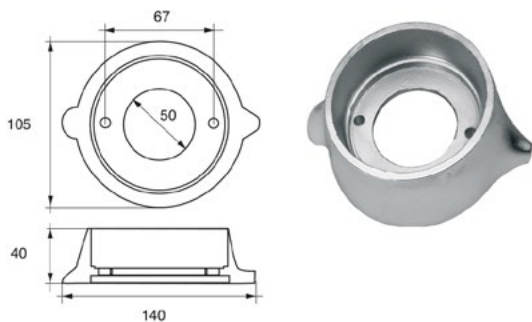

Anodi per motori Bombardier (Johnson-Evinrude-OMC)

Anodes for Bombardier engines (Johnson-Evinrude-OMC)

| Articolo - Item | €/pc. | Art. POLIPODIO | Mod. | Mat. |
|-----------------|-------|----------------|---|------|
| L 81 47 301 | | OM001 | FG-1 con viti inox O.C.: 123009-327606 Motori HP 2-150 | ZN |
| L 82 47 301 | | OM001AL | O.C.: 123009-327606 Motori HP 2-150 | AL |

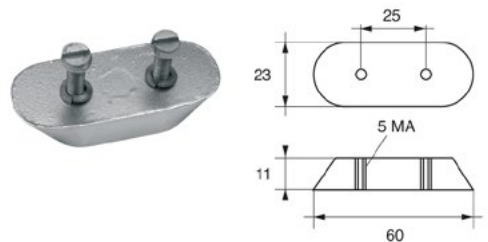

ANODI | ANODES

Anodi per motori Bombardier (Johnson-Evinrude-OMC)

Anodes for Bombardier engines (Johnson-Evinrude-OMC)

| Articolo - Item | €/pc. | Art. POLIPODIO | Mod. | Mat. |
|-----------------|-------|----------------|-----------------------------------|------|
| L 81 47 303 | | OM002 | FG-2 O.C.: 392462 Motori HP 50-75 | ZN |
| L 82 47 303 | | OM002AL | O.C.: 392462 Motori HP 50-75 | AL |

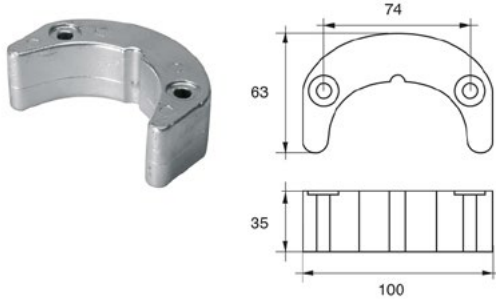

Anodo per motori Bombardier (Johnson-Evinrude-OMC)

Anode for Bombardier engines (Johnson-Evinrude-OMC)

| Articolo - Item | €/pc. | Art. POLIPODIO | Mod. | Mat. |
|-----------------|-------|----------------|--|------|
| L 81 47 302 | | OM003 | FG-3 Original Code: 392123 Motori HP 90÷140 | ZN |

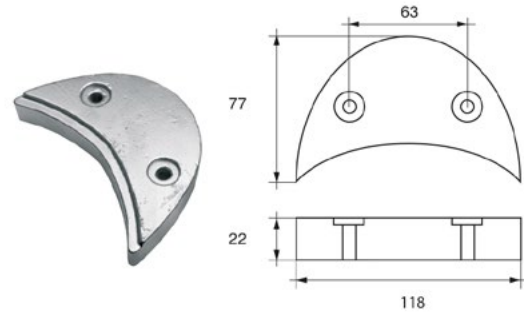

Anodi per motori Bombardier (Johnson-Evinrude-OMC)

Anodes for Bombardier engines (Johnson-Evinrude-OMC)

| Articolo - Item | €/pc. | Art. POLIPODIO | Mod. | Mat. |
|-----------------|-------|----------------|------------------------------------|------|
| L 81 42 304 | | OM004 | FG-4 O.C.: 436745 Motori HP 50÷200 | ZN |
| L 82 42 304 | | OM004AL | O.C.: 436745 Motori HP 50÷200 | AL |

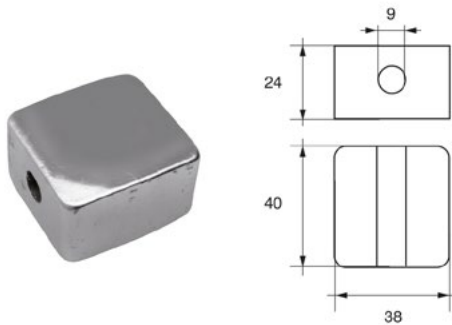

Anodi per motori Bombardier (Johnson-Evinrude-OMC)

Anodes for Bombardier engines (Johnson-Evinrude-OMC)

| Articolo - Item | €/pc. | Art. POLIPODIO | Mod. | Mat. |
|-----------------|-------|----------------|-----------------------------------|------|
| L 81 47 305 | | OM005 | FG-5 O.C.: 334451 Motori HP 4÷7,5 | ZN |

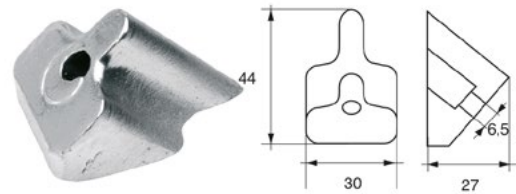

Anodi per motori Bombardier (Johnson-Evinrude-OMC)

Anodes for Bombardier engines (Johnson-Evinrude-OMC)

| Articolo - Item | €/pc. | Art. POLIPODIO | Mod. | Mat. |
|-----------------|-------|----------------|--|------|
| L 81 47 314 | | OM015 | FG-4 BIS O.C.: 433458 Motori HP 60÷280 | ZN |
| L 82 47 314 | | OM015AL | O.C.: 433458 Motori HP 60÷280 | AL |

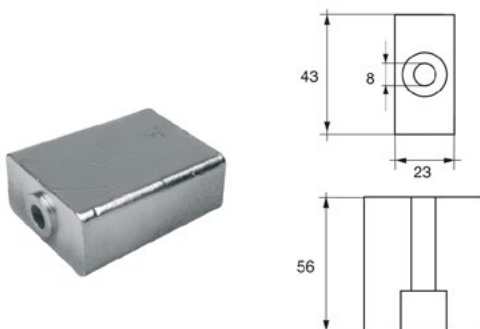

Anodo per motori Bombardier (Johnson-Evinrude-OMC)

Anode for Bombardier engines (Johnson-Evinrude-OMC)

| Articolo - Item | €/pc. | Art. POLIPODIO | Mod. | Mat. |
|-----------------|-------|----------------|--|------|
| L 81 47 337 | | OM011 | FG-11 O.C.: 398873 Motori HP 40-50 Motore 737 | ZN |

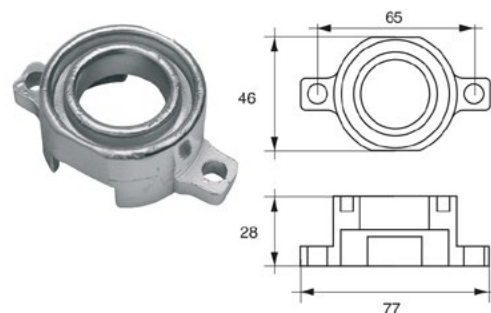

ANODI | ANODES

Anodo per motori Bombardier (Johnson-Evinrude-OMC) Anode for Bombardier engines (Johnson-Evinrude-OMC)

| Articolo - Item | €/pc. | Art. POLIPODIO | Mod. | Mat. |
|-----------------|-------|----------------|----------------------------------|------|
| L 81 42 012 | | OM012 | F-OMC-P Original Code: 976669 | ZN |

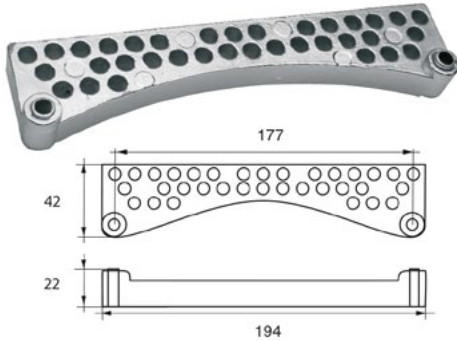

Anodo per motori Bombardier (Johnson-Evinrude-OMC) Anode for Bombardier engines (Johnson-Evinrude-OMC)

| Articolo - Item | €/pc. | Art. POLIPODIO | Mod. | Mat. |
|-----------------|-------|----------------|----------------------------------|------|
| L 81 42 019 | | OM014 | F-OMC-G Original Code: 982432 | ZN |

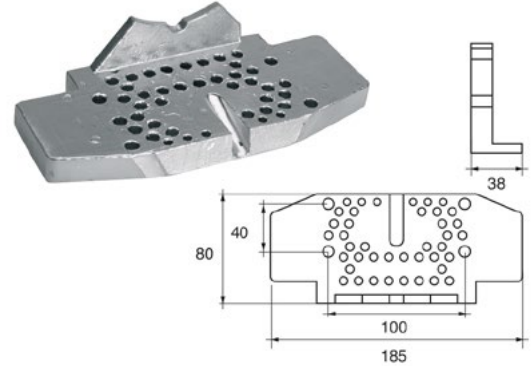

Anodo per motori Bombardier (Johnson-Evinrude-OMC) Anode for Bombardier engines (Johnson-Evinrude-OMC)

| Articolo - Item | €/pc. | Art. POLIPODIO | Mod. | Mat. |
|-----------------|-------|----------------|--|------|
| L 81 47 306 | | OM006 | FG-6 Original Code: 398331 Motori HP 60÷175 | ZN |

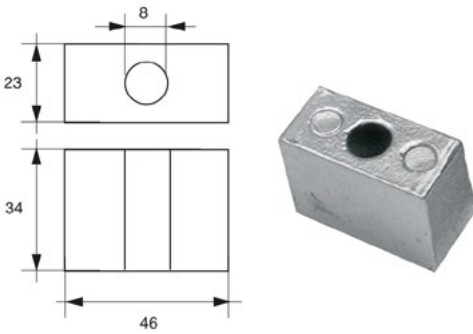

Anodi per motori Bombardier (Johnson-Evinrude-OMC) Anodes for Bombardier engines (Johnson-Evinrude-OMC)

| Articolo - Item | €/pc. | Art. POLIPODIO | Mod. | Mat. |
|-----------------|-------|----------------|--|------|
| L 81 42 307 | | OM007 | FG-7 con viti inox-with SS screws O.C.: 983494 Motori HP 90÷140÷175 | ZN |
| L 82 42 307 | | OM007AL | O.C.: 983494 Motori HP 90÷140÷175 | AL |

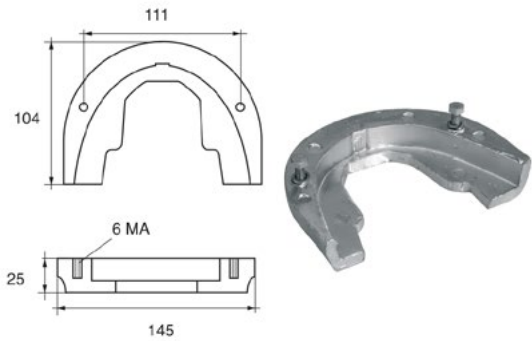

Anodi per motori Bombardier (Johnson-Evinrude-OMC) Anodes for Bombardier engines (Johnson-Evinrude-OMC)

| Articolo - Item | €/pc. | Art. POLIPODIO | Mod. | Mat. |
|-----------------|-------|----------------|--|------|
| L 81 42 308 | | OM008 | FG-7/C con viti inox-with SS screws Original Code: 3853818 KING COBRA | ZN |
| L 82 42 308 | | OM008AL | Original Code: 3853818 KING COBRA | AL |

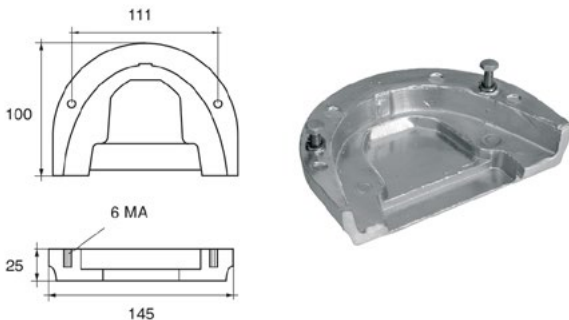

Anodo per motori Bombardier (Johnson-Evinrude-OMC) Anode for Bombardier engines (Johnson-Evinrude-OMC)

| Articolo - Item | €/pc. | Art. POLIPODIO | Mod. | Mat. |
|-----------------|-------|----------------|--|------|
| L 81 42 001 | | OM009 | FG-8 Original Code: 983952 Motori HP 130÷385 COBRA | ZN |

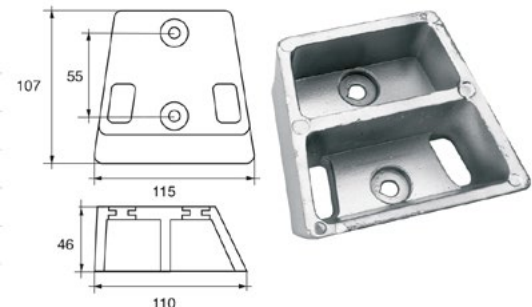

ANODI | ANODES

Anodo per motori Bombardier (Johnson-Evinrude-OMC) Anode for Bombardier engines (Johnson-Evinrude-OMC)

| Articolo - Item | €/pc. | Art. POLIPODIO | Mod. | Mat. |
|-----------------|-------|----------------|---|------|
| L 81 47 310 | | OM016 | FG-10 con viti inox-with SS screws O.C.: 434029 Motori HP 20-25 2 CYL. Motori HP 25-35 3 CYL. | ZN |

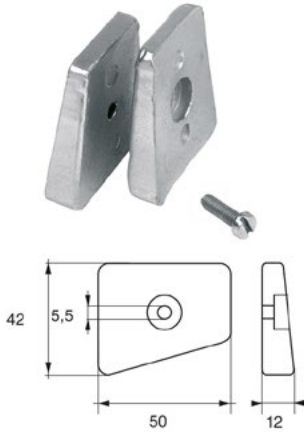

Anodo per motori Bombardier (Johnson-Evinrude-OMC) Anode for Bombardier engines (Johnson-Evinrude-OMC)

| Articolo - Item | €/pc. | Art. POLIPODIO | Mod. | Mat. |
|-----------------|-------|----------------|---|------|
| L 81 47 315 | | OM017 | FG-12 O.C.: 338635 Motori HP 9,9±15 4T | ZN |

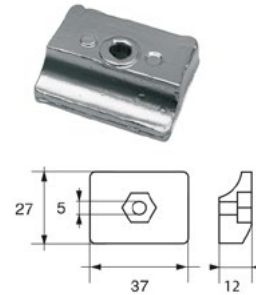

Anodi per motori Bombardier (Johnson-Evinrude-OMC) Anodes for Bombardier engines (Johnson-Evinrude-OMC)

| Articolo - Item | €/pc. | Art. POLIPODIO | Mod. | Mat. |
|-----------------|-------|----------------|--------------------------------|------|
| L 81 47 013 | | OM018A | F-OMC-H Original Code: 5007089 | ZN |
| L 82 47 013 | | OM018A/AL | Original Code: 5007089 | AL |

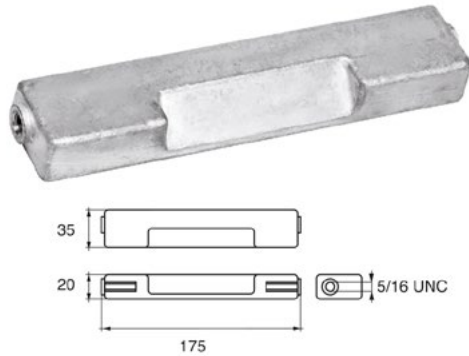

Anodo per motori Bombardier (Johnson-Evinrude-OMC) Anode for Bombardier engines (Johnson-Evinrude-OMC)

| Articolo - Item | €/pc. | Art. POLIPODIO | Mod. | Mat. |
|-----------------|-------|----------------|--|------|
| L 81 42 010 | | OM019 | F-OMC-22 Original Code: 986158 COBRA SX | ZN |

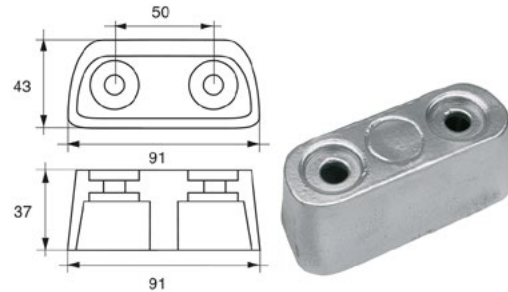

Anodi per motori Bombardier (Johnson-Evinrude-OMC) Anodes for Bombardier engines (Johnson-Evinrude-OMC)

| Articolo - Item | €/pc. | Art. POLIPODIO | Mod. | Mat. |
|-----------------|-------|----------------|---------------------------------------|------|
| L 81 47 311 | | OM021 | O.C.: 431708 FICHT RAM HP 135-150-175 | ZN |

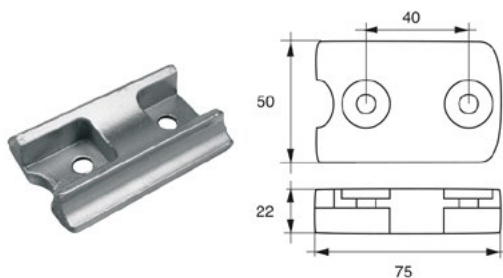

Anodi per motori Bombardier (Johnson-Evinrude-OMC) Anodes for Bombardier engines (Johnson-Evinrude-OMC)

| Articolo - Item | €/pc. | Art. POLIPODIO | Mod. | Mat. |
|-----------------|-------|----------------|-----------------------------------|------|
| L 81 42 002 | | OM022 | F-OMC-25 O.C.: 3854130 KING COBRA | ZN |
| L 82 40 002 | | OM022AL | Original Code: 3854130 KING COBRA | AL |

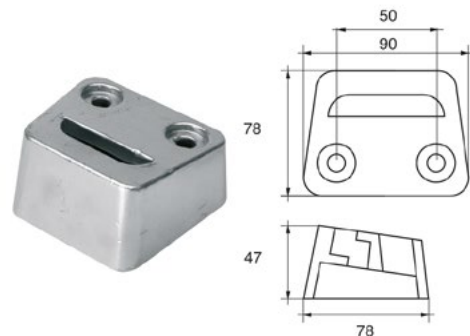

ANODI | ANODES

Anodi per motori Bombardier (Johnson-Evinrude-OMC) Anodes for Bombardier engines (Johnson-Evinrude-OMC)

| Articolo - Item | €/pc. | Art. POLIPODIO | Mod. | Mat. |
|-----------------|-------|----------------|--|------|
| L 81 44 214 | | OM023 | FG-13 O.C.: 5034616 EVINRUDE HP 70 4T | ZN |

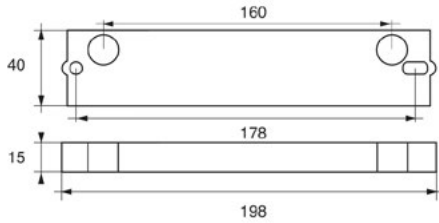

Anodi per motori Honda Anodes for Honda engines

| Articolo - Item | €/pc. | Art. POLIPODIO | Mod. | Mat. |
|-----------------|-------|----------------|---|------|
| L 81 50 808 | | HN006 | FH-5 O.C.: 41107-ZV-5000 MOTORI HP 25-40-50 | ZN |
| L 82 50 808 | | HN006AL | FH-5 O.C.: 41107-ZV-5000 MOTORI HP 25-40-50 | AL |

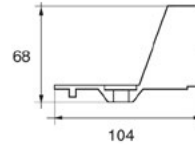
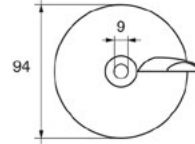

Anodi per motori Honda Anodes for Honda engines

| Articolo - Item | €/pc. | Art. POLIPODIO | Mod. | Mat. |
|-----------------|-------|----------------|---------------------------------------|------|
| L 81 50 801 | | HN012 | FH-12 Original Code: 12155-ZV4-A00 | ZN |
| L 82 50 801 | | HN012AL | FH-12 Original Code: 12155-ZV4-A00 | AL |

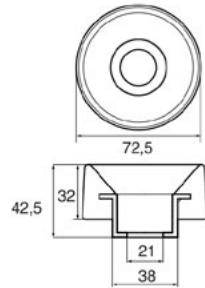

Anodi per motori Honda Anodes for Honda engines

| Articolo - Item | €/pc. | Art. POLIPODIO | Mod. | Mat. |
|-----------------|-------|----------------|--|------|
| L 81 50 805 | | HN008 | FH-7 Original Code: 41109-ZW1-B00 Motori HP 75-130-225 | ZN |
| L 82 50 805 | | HN008AL | FH-7 Original Code: 41109-ZW1-B00 Motori HP 75-130-225 | AL |

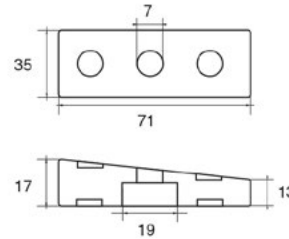

Anodo per motori Honda Anode for Honda engines

| Articolo - Item | €/pc. | Art. POLIPODIO | Mod. | Mat. |
|-----------------|-------|----------------|---|------|
| L 81 50 803 | | HN009 | FH-9 Original Code: 41106-ZW9-000 Motori HP 8-10-15 | ZN |

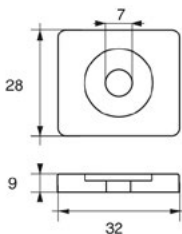
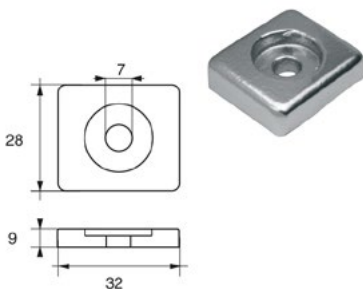

Anodi per motori Honda Anodes for Honda engines

| Articolo - Item | €/pc. | Art. POLIPODIO | Mod. | Mat. |
|-----------------|-------|----------------|--|------|
| L 81 50 807 | | HN010 | FH-12 Original Code: 41107-ZW1-B01ZA Motori HP 75-90-115-130 | ZN |
| L 82 50 807 | | HN010AL | FH-12 Original Code: 41107-ZW1-B01ZA Motori HP 75-90-115-130 | AL |

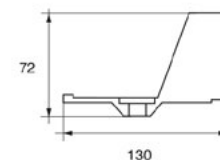
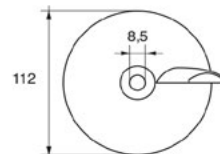

ANODI | ANODES

Anodi per motori Honda

Anodes for Honda engines

| Articolo - Item | €/pc. | Art. POLIPODIO | Mod. | Mat. |
|-----------------|-------|----------------|---|------|
| L 81 50 806 | | HN001 | FH-1 con viti inox-with SS screws Original Code: 411062W-9000 MOTORI HP 8-15-20 | ZN |
| L 82 50 806 | | HN001AL | Original Code: 411062W-9000 MOTORI HP 8-15-20 | AL |

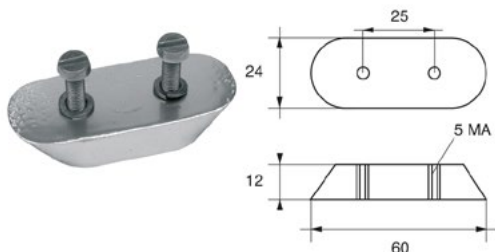

Anodi per motori Honda

Anodes for Honda engines

| Articolo - Item | €/pc. | Art. POLIPODIO | Mod. | Mat. |
|-----------------|-------|----------------|--|------|
| L 81 50 802 | | HN002 | FD-24 O.C.: 4106-ZW-000 MOTORI HP 8 | ZN |
| L 82 50 802 | | HN002AL | O.C.: 4106-ZW-000 MOTORI HP 8 | AL |

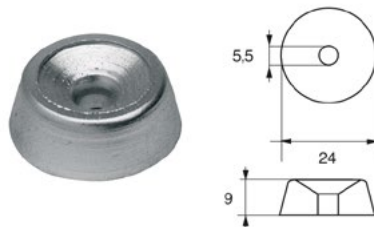

Anodi per motori Honda

Anodes for Honda engines

| Articolo - Item | €/pc. | Art. POLIPODIO | Mod. | Mat. |
|-----------------|-------|----------------|---|------|
| L 81 50 812 | | HN003 | FH-2 Original Code: 06411-ZV-5000 Motori HP 40-50 | ZN |
| L 82 50 812 | | HN003AL | Original Code: 06411-ZV-5000 Motori HP 40-50 | AL |

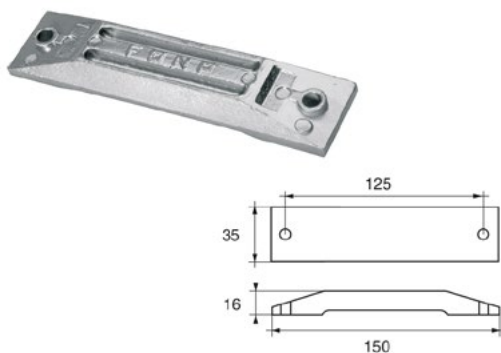

Anodi per motori Honda

Anodes for Honda engines

| Articolo - Item | €/pc. | Art. POLIPODIO | Mod. | Mat. |
|-----------------|-------|----------------|--|------|
| L 81 50 814 | | HN004 | FH-3 Original Code: 06411-ZW1-000 Motori HP 75÷130 | ZN |
| L 82 50 814 | | HN004AL | Original Code: 06411-ZW1-000 Motori HP 75÷130 | AL |

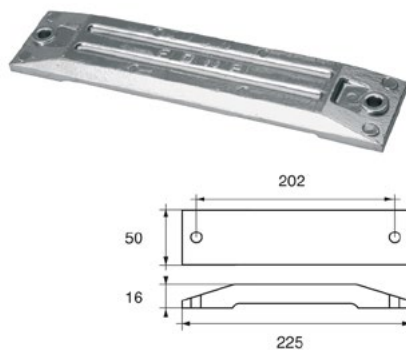

Anodi per motori Honda

Anodes for Honda engines

| Articolo - Item | €/pc. | Art. POLIPODIO | Mod. | Mat. |
|-----------------|-------|----------------|--|------|
| L 81 50 804 | | HN005 | FH-4 Original Code: 41109-ZW-1003 Motori HP 75÷130 | ZN |
| L 82 50 804 | | HN005AL | Original Code: 41109-ZW-1003 Motori HP 75÷130 | AL |

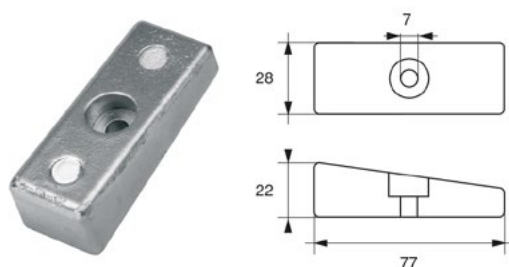

Anodo per motori Lombardini

Anode for Lombardini engines

| Articolo - Item | €/pc. | Art. POLIPODIO | Mod. | Mat. |
|-----------------|-------|----------------|------------------------|------|
| L 81 41 553 | | LB004 | Original Code: 9135034 | ZN |

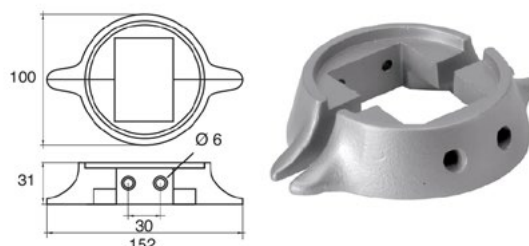

ANODI | ANODES

Anodi per motori Mercury-Mercruiser Anodes for engines Mercury-Mercruiser

| Articolo - Item | €/pc. | Art. POLIPODIO | Mod. | Mat. |
|-----------------|-------|----------------|---|------|
| L 81 43 350 | | ME001 | FM-1 Original Code: 31640Q4 Motori HP 40 EFI-50-75 4T | ZN |
| L 82 43 350 | | ME001AL | Original Code: 31640Q4 Motori HP 40 EFI-50-75 4T | AL |

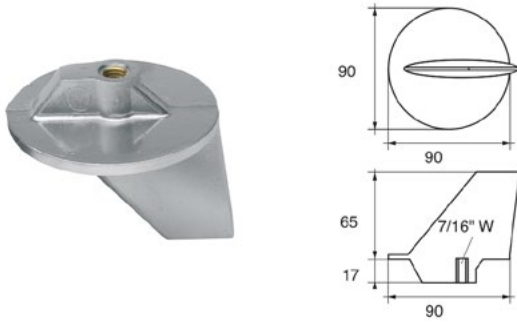

Anodi per motori Mercury-Mercruiser Anodes for engines Mercury-Mercruiser

| Articolo - Item | €/pc. | Art. POLIPODIO | Mod. | Mat. |
|-----------------|-------|----------------|---------------------------------------|------|
| L 81 43 016 | | ME002 | FM-2 O.C.: 34127A1MOTORI HP 80-140 | ZN |

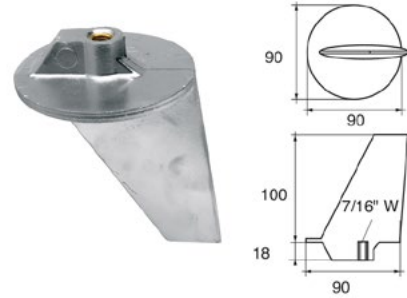

Anodo per motori Mercury-Mercruiser Anode for engines Mercury-Mercruiser

| Articolo - Item | €/pc. | Art. POLIPODIO | Mod. | Mat. |
|-----------------|-------|----------------|---------------------------------|------|
| L 81 45 303 | | ME003 | FM-3 O.C.: 47820A1 Motori HP 20 | ZN |

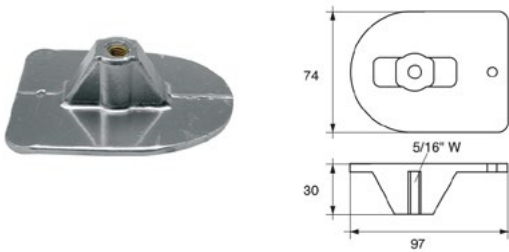

Anodo per motori Mercury-Mercruiser Anode for engines Mercury-Mercruiser

| Articolo - Item | €/pc. | Art. POLIPODIO | Mod. | Mat. |
|-----------------|-------|----------------|------------------------------------|------|
| L 81 45 304 | | ME004 | FM-4 O.C.: 94286T1 Motori HP 20-25 | ZN |

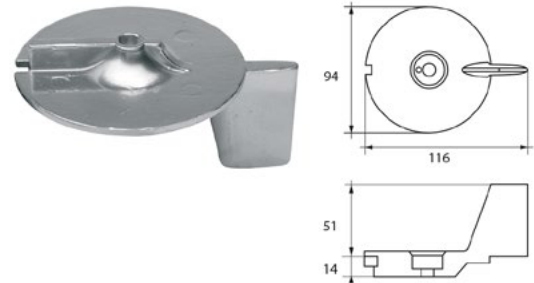

Anodo per motori Mercury-Mercruiser Anode for engines Mercury-Mercruiser

| Articolo - Item | €/pc. | Art. POLIPODIO | Mod. | Mat. |
|-----------------|-------|----------------|---|------|
| L 81 45 305 | | ME005 | FM-5 O.C.: 9843296 Motori HP 15-25 4T (dopo il 1990-after 1990) | ZN |

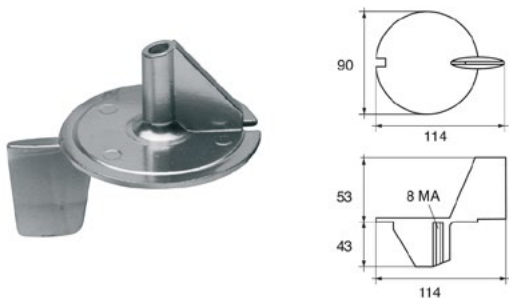

Anodi per motori Mercury-Mercruiser Anodes for engines Mercury-Mercruiser

| Articolo - Item | €/pc. | Art. POLIPODIO | Mod. | A mm. | B mm. | C mm. | Mat. |
|-----------------|-------|----------------|----------|-------|-------|-------|------|
| L 81 45 312 | | ME006 | F-D-20/M | 20 | 8 | 6 | ZN |
| L 82 45 312 | | ME006AL | | 20 | 8 | 6 | AL |
| L 81 45 311 | | ME006B | | 24 | 6,5 | 5,5 | ZN |
| L 82 45 311 | | ME006B/AL | | 24 | 6,5 | 5,5 | AL |

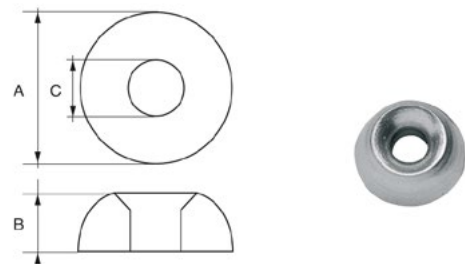

**Anodo per motori
Mercury-Mercruiser**

**Anode for engines
Mercury-Mercruiser**

| Articolo - Item | €/pc. | Art. POLIPODIO | Mod. | Mat. |
|-----------------|-------|-------------------|---|------|
| L 81 45 505 | | | ZINC Original Code: 853762 Motore 40 XR | ZN |



**Anodi per motori
Mercury-Mercruiser**

**Anodes for engines
Mercury-Mercruiser**

| Articolo - Item | €/pc. | Art. POLIPODIO | Mod. | Mat. |
|-----------------|-------|-------------------|---|------|
| L 81 43 005 | | ME010 | Original Code: 55989Q9 Serie ALPHA ONE-BRAVO ONE | ZN |
| L 82 43 005 | | ME010AL | Original Code: 55989Q9 Serie ALPHA ONE-BRAVO ONE | AL |

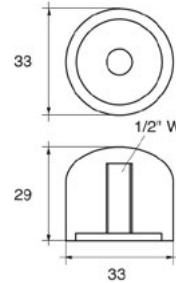

**Anodo per motori
Mercury-Mercruiser**

**Anode for engines
Mercury-Mercruiser**

| Articolo - Item | €/pc. | Art. POLIPODIO | Mod. | Mat. |
|-----------------|-------|-------------------|--|------|
| L 81 45 203 | | ME008 | FM-7 BIS Original Code: 42121A2 Motori HP 6-9,9-15 4T | ZN |

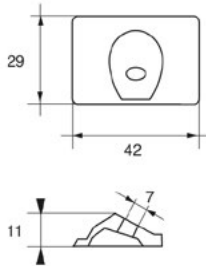

**Anodi per motori
Mercury-Mercruiser**

**Anodes for engines
Mercury-Mercruiser**

| Articolo - Item | €/pc. | Art. POLIPODIO | Mod. | Mat. |
|-----------------|-------|-------------------|--|------|
| L 81 45 320 | | ME011 | Original Code: 818298Q1 Motori HP 40÷75 - HP 40÷250 | ZN |
| L 82 45 320 | | ME011AL | Original Code: 818298Q1 Motori HP 40÷75 - HP 40÷250 | AL |

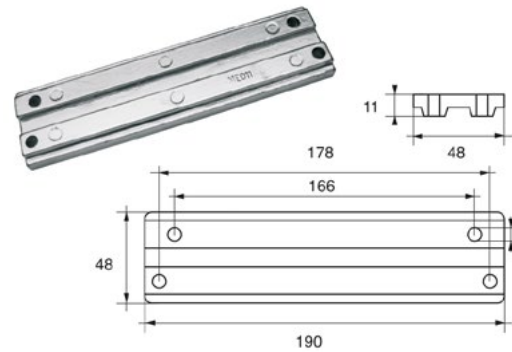

**Anodo per motori
Mercury-Mercruiser**

**Anode for engines
Mercury-Mercruiser**

| Articolo - Item | €/pc. | Art. POLIPODIO | Mod. | Mat. |
|-----------------|-------|-------------------|--|------|
| L 81 43 325 | | ME012 | F-ME/SA Original Code: 43396 MERCURY: HP 50÷75 MERCURUISER: E.B. HP 90-100 SUPER AMERICA: HP 80-115 | ZN |

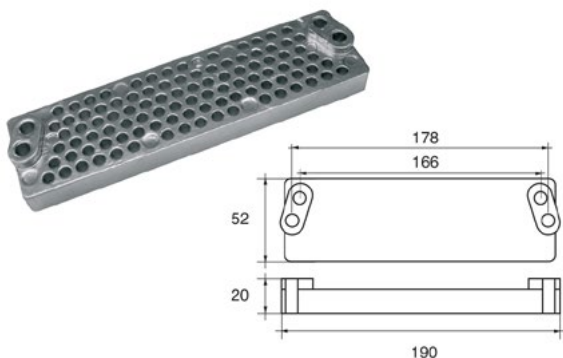

**Anodi per motori
Mercury-Mercruiser**

**Anodes for engines
Mercury-Mercruiser**

| Articolo - Item | €/pc. | Art. POLIPODIO | Mod. | Mat. |
|-----------------|-------|-------------------|---|------|
| L 81 43 013 | | ME013 | FM-13 con viti inox-with SS screws Original Code: 821629Q1 ALPHA ONE | ZN |
| L 82 43 013 | | ME013AL | Original Code: 821629Q1 ALPHA ONE | AL |

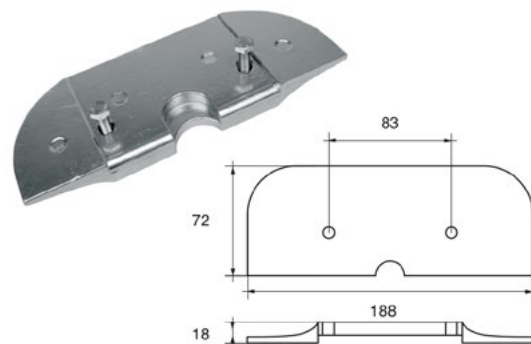

ANODI | ANODES

Anodi per motori Mercury-Mercruiser

Anodes for engines Mercury-Mercruiser

| Articolo - Item | €/pc. | Art. POLIPODIO | Mod. | Mat. |
|-----------------|-------|----------------|--|------|
| L 81 43 014 | | ME014 | FM-14 Original Code: 821630Q1 SERIE BRAVO | ZN |
| L 82 43 014 | | ME014AL | Original Code: 821630Q1 SERIE BRAVO | AL |

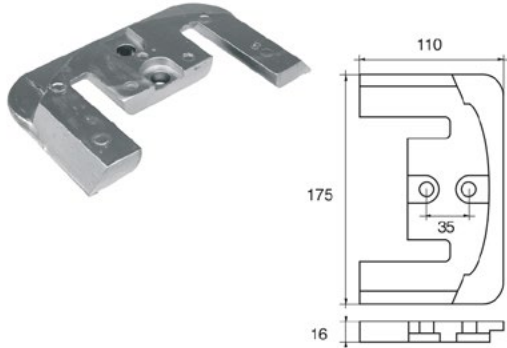

Anodo per motori Mercury-Mercruiser

Anode for engines Mercury-Mercruiser

| Articolo - Item | €/pc. | Art. POLIPODIO | Mod. | Mat. |
|-----------------|-------|----------------|--|------|
| L 81 43 012 | | ME015 | FM-12.: 822777Q1 ELICA INOX HP 50/140 BRAVO ONE | ZN |

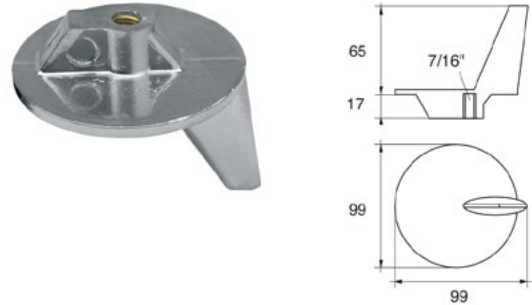

Anodi per motori Mercury-Mercruiser

Anodes for engines Mercury-Mercruiser

| Articolo - Item | €/pc. | Art. POLIPODIO | Mod. | Mat. |
|-----------------|-------|----------------|--|------|
| L 81 43 117 | | ME017 | FM-15 Original Code: 806189Q1 ALPHA ONE | ZN |
| L 82 43 117 | | ME017AL | Original Code: 806189Q1 ALPHA ONE | AL |

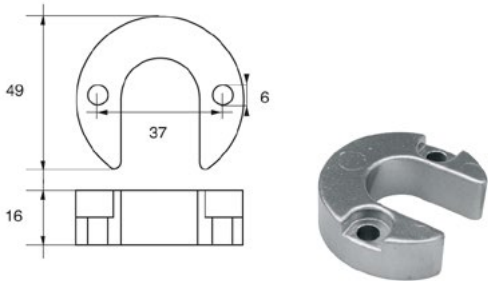

Anodi per motori Mercury-Mercruiser

Anodes for engines Mercury-Mercruiser

| Articolo - Item | €/pc. | Art. POLIPODIO | Mod. | Mat. |
|-----------------|-------|----------------|---|------|
| L 81 45 310 | | ME018 | FM-16 O.C.: 826134Q Motori HP 75=250-75 4T | ZN |
| L 82 45 310 | | ME018AL | O.C.: 826134Q Motori HP 75=250-75 4T | AL |

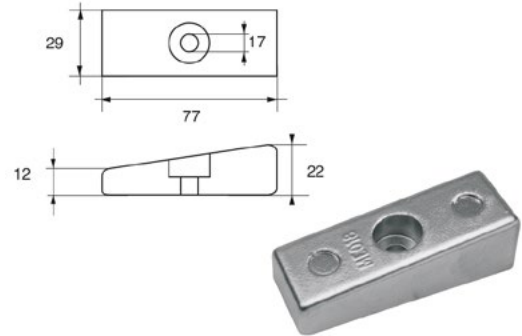

Anodi per motori Mercury-Mercruiser

Anodes for engines Mercury-Mercruiser

| Articolo - Item | €/pc. | Art. POLIPODIO | Mod. | Mat. |
|-----------------|-------|----------------|--|------|
| L 81 43 119 | | ME019 | FM-17 Original Code: 806105Q1 ALPHA ONE | ZN |
| L 82 43 119 | | ME019AL | Original Code: 806105Q1 ALPHA ONE | AL |

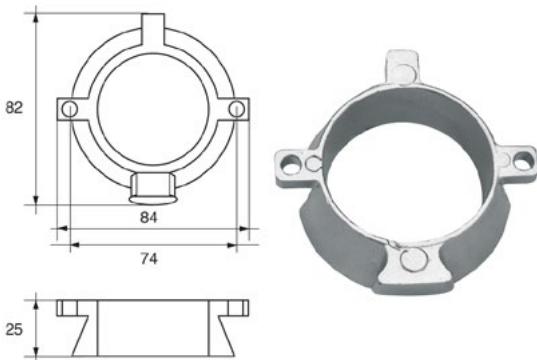

Anodi per motori Mercury-Mercruiser

Anodes for engines Mercury-Mercruiser

| Articolo - Item | €/pc. | Art. POLIPODIO | Mod. | Mat. |
|-----------------|-------|----------------|--|------|
| L 81 45 514 | | ME030 | FM-29 Original Code: 823912002 Motori HP 40 | ZN |
| L 82 45 514 | | ME030AL | Original Code: 823912002 Motori HP 40 | AL |

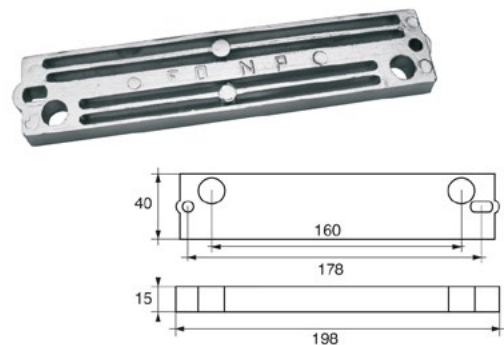

Anodo per motori Mercury-Mercruiser

Anode for engines Mercury-Mercruiser

| Articolo - Item | €/pc. | Art. POLIPODIO | Mod. | Mat. |
|-----------------|-------|----------------|---|------|
| L 81 45 018 | | ME020 | FM-18 Original Code: 17264T2 FORMULA 850 | ZN |

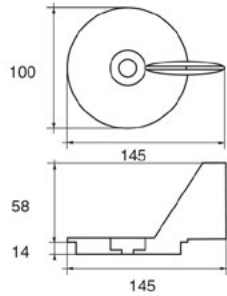

Anodi per motori Mercury-Mercruiser

Anodes for engines Mercury-Mercruiser

| Articolo - Item | €/pc. | Art. POLIPODIO | Mod. | Mat. |
|-----------------|-------|----------------|--|------|
| L 81 43 118 | | ME021 | FM-19 Original Code: 806190Q1 BRAVO THREE | ZN |
| L 82 43 118 | | ME021AL | Original Code: 806190Q1 BRAVO THREE | AL |

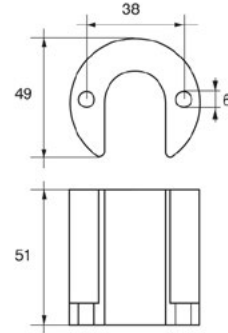

Anodi per motori Mercury-Mercruiser

Anodes for engines Mercury-Mercruiser

| Articolo - Item | €/pc. | Art. POLIPODIO | Mod. | Mat. |
|-----------------|-------|----------------|---|------|
| L 81 43 120 | | ME022 | FM-20 Original Code: 76214-5 Motori HP 150÷250 ALPHA | ZN |
| L 82 43 120 | | ME022AL | Original Code: 76214-5 Motori HP 150÷250 ALPHA | AL |

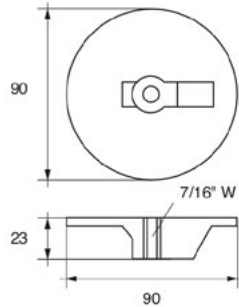

Anodi per motori Mercury-Mercruiser

Anodes for engines Mercury-Mercruiser

| Articolo - Item | €/pc. | Art. POLIPODIO | Mod. | Mat. |
|-----------------|-------|----------------|--------------------------------------|------|
| L 81 43 122 | | ME035 | FM-35 Original Code: 76214-4 BRAVO 2 | ZN |
| L 82 43 122 | | ME035AL | Original Code: 76214-4 BRAVO 2 | AL |

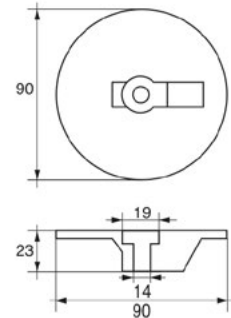

Anodi per motori Mercury-Mercruiser

Anodes for engines Mercury-Mercruiser

| Articolo - Item | €/pc. | Art. POLIPODIO | Mod. | Mat. |
|-----------------|-------|----------------|--|------|
| L 81 43 201 | | ME023 | FM-21 Original Code: 822157T2 Motori HP 25-30-40 4T | ZN |
| L 82 45 017 | | ME023AL | Original Code: 822157T2 Motori HP 25-30-40 4T | AL |

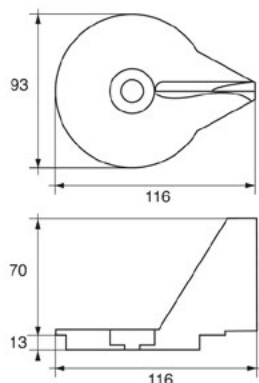

Anodo per motori Mercury-Mercruiser

Anode for engines Mercury-Mercruiser

| Articolo - Item | €/pc. | Art. POLIPODIO | Mod. | Mat. |
|-----------------|-------|----------------|---|------|
| L 81 45 323 | | ME027 | FM-25 Original Code: 89949A1 Motori HP 150-200 | ZN |

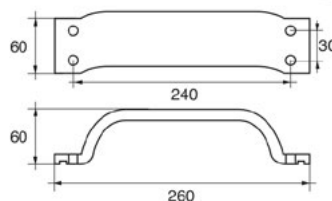
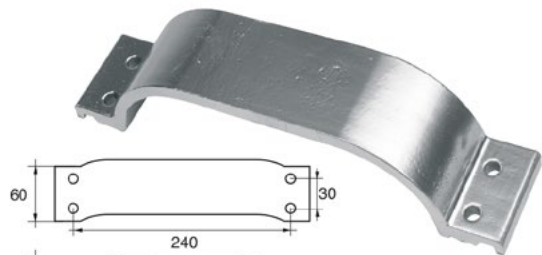

ANODI | ANODES

Anodi per motori Mercury-Mercruiser

| Articolo - Item | €/pc. | Art. | | Mat. |
|-----------------|-------|-----------|--|------|
| | | POLIPODIO | Mod. | |
| L 81 43 121 | | ME028 | FM-28 Original Code: 806188A1 BRAVO ONE | ZN |
| L 82 43 121 | | ME028AL | Original Code: 806188A1 BRAVO ONE | AL |

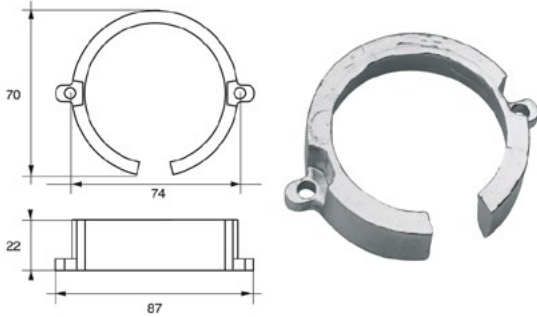

Anodi per motori Mercury-Mercruiser

| Articolo - Item | €/pc. | Art. | | Mat. |
|-----------------|-------|-----------|--------------------------------|------|
| | | POLIPODIO | Mod. | |
| L 81 49 214 | | ME037 | FM-37 Motori HP 215-275 VERADO | ZN |
| L 82 49 214 | | ME037AL | Motori HP 215-275 VERADO | AL |

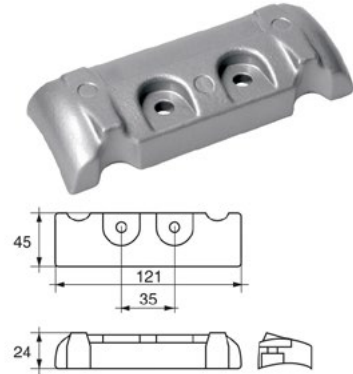

Anodi per motori Mercury-Mercruiser

| Articolo - Item | €/pc. | Art. | | Mat. |
|-----------------|-------|-----------|--|------|
| | | POLIPODIO | Mod. | |
| L 81 49 212 | | ME038 | FM-38 O.C.: 893404 Motori HP 215-275 VERADO | ZN |
| L 82 49 212 | | ME038AL | O.C.: 893404 Motori HP 215-275 VERADO | AL |

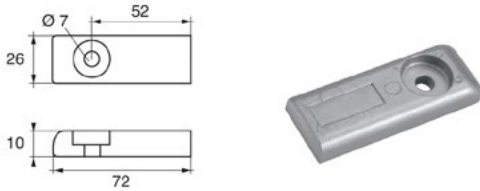

Anodo per motori Mercury-Mercruiser

| Articolo - Item | €/pc. | Art. | | Mat. |
|-----------------|-------|-----------|------------------------------|------|
| | | POLIPODIO | Mod. | |
| L 81 45 202 | | ME039 | FM-39 Original Code: 826887M | ZN |

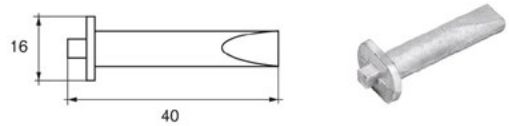

Anodi per motori Mercury-Mercruiser

| Articolo - Item | €/pc. | Art. | | Mat. |
|-----------------|-------|-----------|---|------|
| | | POLIPODIO | Mod. | |
| L 81 43 001 | | ME016 | FM-01 Original Code: 43994A2 ALPHA II GENERATION | ZN |

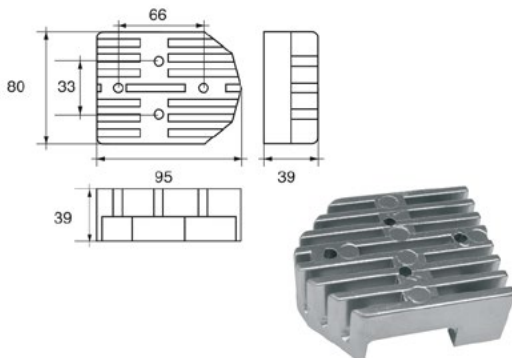

Anodi per motori Mercury-Mercruiser

| Articolo - Item | €/pc. | Art. | | Mat. |
|-----------------|-------|-----------|--|------|
| | | POLIPODIO | Mod. | |
| L 81 49 204 | | ME033 | FM-32 Original Code: 875208 Motori HP 4-5,5 | ZN |
| L 82 49 204 | | ME033AL | Original Code: 875208 Motori HP 4-5,5 | AL |

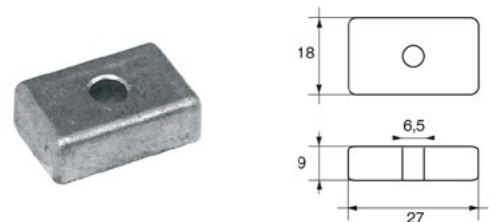

**Anodi per motori
Mercury-Mercruiser**

**Anodes for engines
Mercury-Mercruiser**

| Articolo - Item | €/pc. | Art. POLIPODIO | Mod. | Mat. |
|-----------------|-------|-------------------|---|------|
| L 81 43 125 | | ME034 | FM-34 Original Code: 865182Q01 BRAVO THREE | ZN |
| L 82 43 125 | | ME034AL | Original Code: 865182Q01 BRAVO THREE | AL |

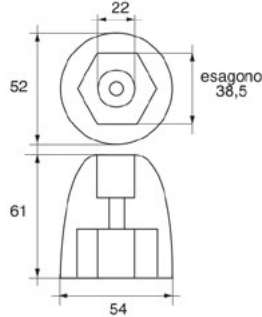

**Anodo per motori
Mercury-Mercruiser**

**Anode for engines
Mercury-Mercruiser**

| Articolo - Item | €/pc. | Art. POLIPODIO | Mod. | Mat. |
|-----------------|-------|-------------------|--|------|
| L 81 45 319 | | ME025 | FM-23 Original Code: 825271-1 Motori HP 25-30-40 4T | ZN |

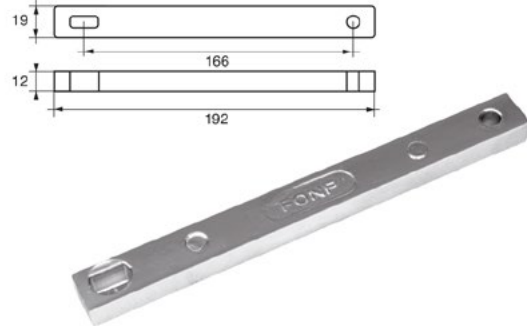

**Anodi per motori
Tohatsu-Nissan**

**Anodes for engines
Tohatsu-Nissan**

| Articolo - Item | €/pc. | Art. POLIPODIO | A | B | C | Mod. | Mat. |
|-----------------|-------|-------------------|----|---|-----|--|------|
| L 81 48 510 | | TH001 | 24 | 8 | 6 | F-T0-5 Original Code: 369-60218-1 Motori HP 2,5-8 | ZN |
| L 82 48 510 | | TH001AL | 24 | 8 | 6 | Original Code: 369-60218-1 Motori HP 2,5-8 | AL |
| L 81 48 512 | | TH001B | 20 | 7 | 6,5 | Original Code: 338-60218-2 Motori HP 2,5-8 | ZN |
| L 82 48 512 | | TH001BAL | 20 | 7 | 6,5 | Original Code: 338-60218-2 Motori HP 2,5-8 | AL |

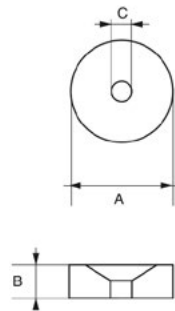

**Anodo per motori
Tohatsu-Nissan**

**Anode for engines
Tohatsu-Nissan**

| Articolo - Item | €/pc. | Art. POLIPODIO | Mod. | Mat. |
|-----------------|-------|-------------------|--|------|
| L 81 48 504 | | TH002 | F-T0-4 Original Code: 3B7-60218-0 MEGA | ZN |

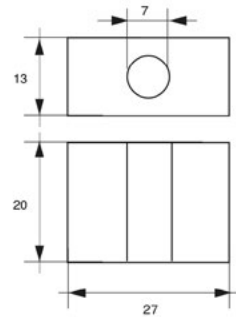

**Anodo per motori
Tohatsu-Nissan**

**Anode for engines
Tohatsu-Nissan**

| Articolo - Item | €/pc. | Art. POLIPODIO | Mod. | Mat. |
|-----------------|-------|-------------------|---|------|
| L 81 48 502 | | TH003 | F-T0-1 Original Code: 348-60217-0 Motori HP 25-40 MAXI/CORSA | ZN |

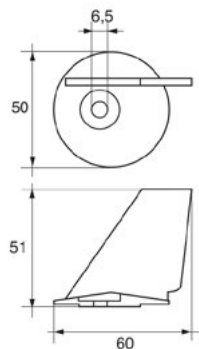

**Anodo per motori
Tohatsu-Nissan**

**Anode for engines
Tohatsu-Nissan**

| Articolo - Item | €/pc. | Art. POLIPODIO | Mod. | Mat. |
|-----------------|-------|-------------------|---|------|
| L 81 48 505 | | TH004 | F-T0-2 Original Code: 3C8-60217-0 Motori HP 25-50 MEGA | ZN |

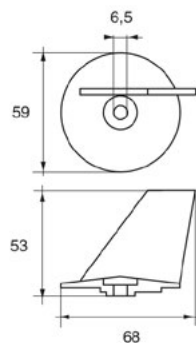

ANODI | ANODES

**Anodo per motori
Tohatsu-Nissan**

| Articolo - Item | €/pc. | Art. POLIPODIO | Mod. | Mat. |
|-----------------|-------|-------------------|---|------|
| L 81 48 507 | | TH005 | F-T0-3 Original Code: 3B7-60217-0 Motori HP 60÷140 XF 70 | ZN |

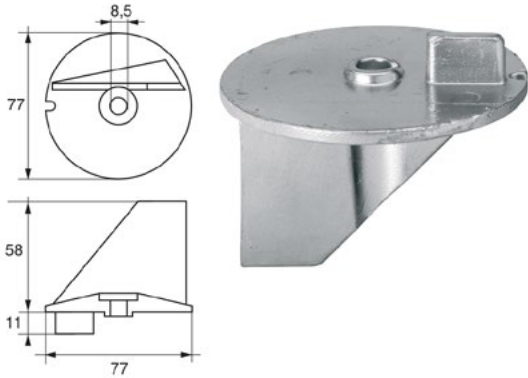

**Anodo per motori
Tohatsu-Nissan**

| Articolo - Item | €/pc. | Art. POLIPODIO | Mod. | Mat. |
|-----------------|-------|-------------------|---|------|
| L 81 48 501 | | TH006 | F-T0-6 Original Code: 3M2-60218-1 Motori HP 40÷140 | ZN |

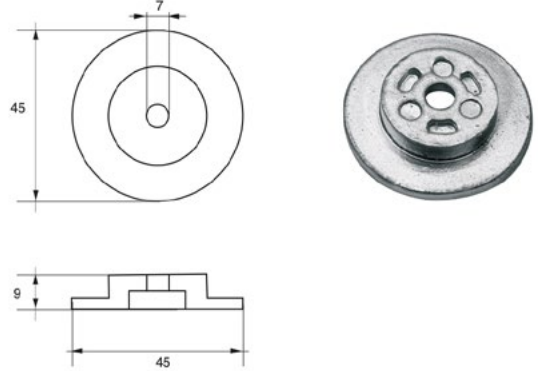

**Anodi per motori
Tohatsu-Nissan**

| Articolo - Item | €/pc. | Art. POLIPODIO | Mod. | Mat. |
|-----------------|-------|-------------------|--|------|
| L 81 48 514 | | TH007 | F-T0-7 Original Code: 3C7-60218-1 Motori HP 40÷140 MEGA | ZN |
| L 82 48 514 | | TH007AL | Original Code: 3C7-60218-1 Motori HP 40÷140 MEGA | AL |

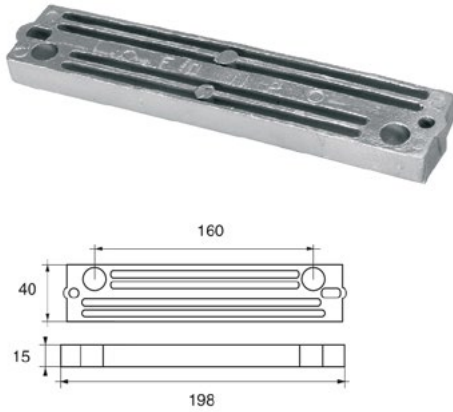

**Anodo per motori
Suzuki**

| Articolo - Item | €/pc. | Art. POLIPODIO | Mod. | Mat. |
|-----------------|-------|-------------------|--|------|
| L 81 44 025 | | SU001 | FM-6/S Original Code: 55125-96310 Pinna Motori HP 20÷30 | ZN |

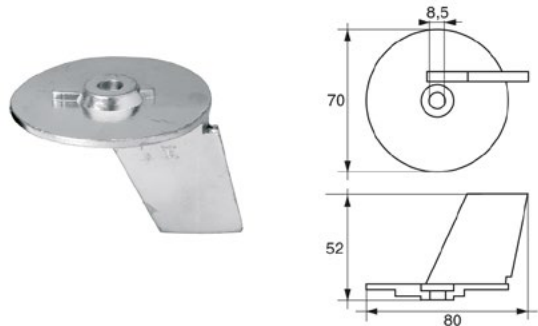

**Anodo per motori
Suzuki**

| Articolo - Item | €/pc. | Art. POLIPODIO | Mod. | Mat. |
|-----------------|-------|-------------------|---|------|
| L 81 44 009 | | SU002 | F-M-9/S Original Code: 55125-95301 Pinna Motori HP 55-65 | ZN |

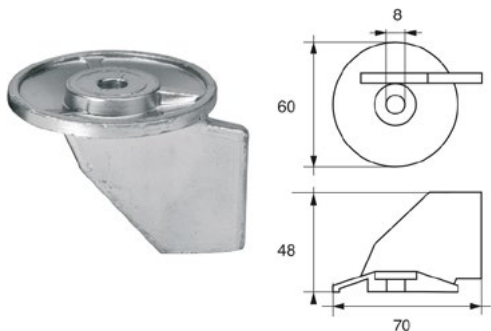

**Anodi per motori
Suzuki**

| Articolo - Item | €/pc. | Art. POLIPODIO | Mod. | Mat. |
|-----------------|-------|-------------------|--|------|
| L 81 44 004 | | SU003 | FM-10/S Original Code: 55320-95310 Motori HP 40÷115 | ZN |

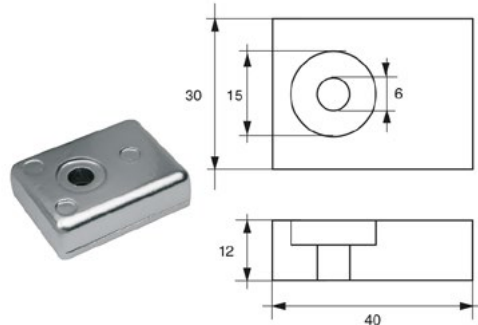

Anodo per motori Suzuki

Anode for engines Suzuki

| Articolo - Item | €/pc. | Art. POLIPODIO | Mod. | Mat. |
|-----------------|-------|----------------|---|------|
| L 81 44 012 | | SU004A | Original Code: 11130-94600 Motori da HP 4÷6 a HP 140÷250 | ZN |

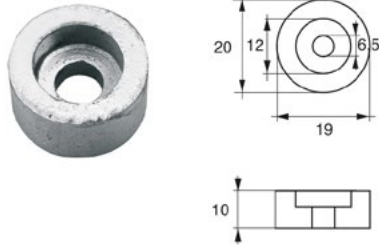

Anodo per motori Suzuki

Anode for engines Suzuki

| Articolo - Item | €/pc. | Art. POLIPODIO | Mod. | Mat. |
|-----------------|-------|----------------|---|------|
| L 81 44 022 | | SU012A | FM-34/S Original Code: 55320-98400 Motori HP 9,9-15 4T | ZN |



Anodi per motori Suzuki

Anodes for engines Suzuki

| Articolo - Item | €/pc. | Art. POLIPODIO | Mod. | Mat. |
|-----------------|-------|----------------|---|------|
| L 81 44 001 | | SU014 | FM-31/S Original Code: 41810-87D00 Motori F.B. | ZN |
| L 82 44 001 | | SU014AL | Original Code: 41810-87D00 Motori F.B. | AL |

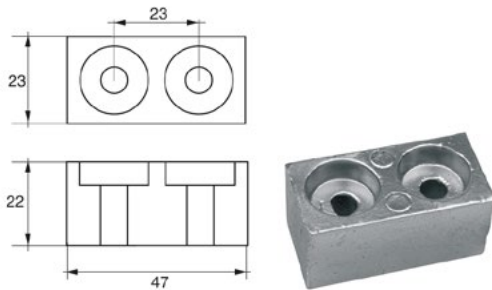

Anodi per motori Suzuki

Anodes for engines Suzuki

| Articolo - Item | €/pc. | Art. POLIPODIO | Mod. | Mat. |
|-----------------|-------|----------------|---|------|
| L 81 44 008 | | SU005 | FM-11/S Original Code: 11130-94600 Motori HP 2÷8 | ZN |

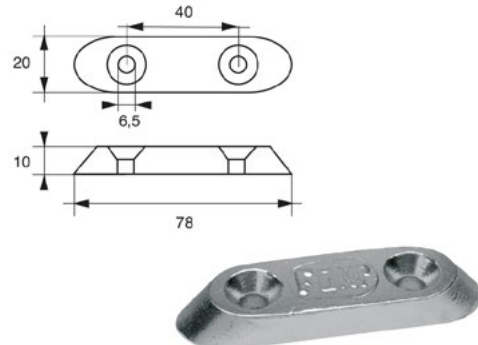

Anodi per motori Suzuki

Anodes for engines Suzuki

| Articolo - Item | €/pc. | Art. POLIPODIO | Mod. | Mat. |
|-----------------|-------|----------------|--|------|
| L 81 44 007 | | SU006 | FM-23/S O.C.: 5031536 / 55125-95500 Motori HP 40-50-75-85 | ZN |

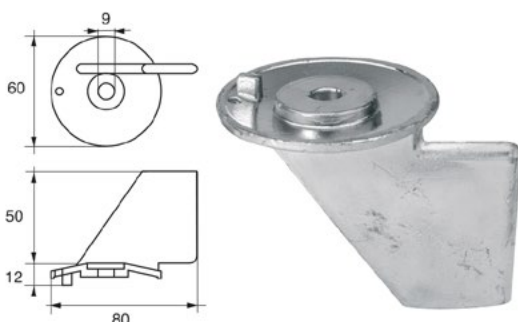

Anodo per motori Suzuki

Anode for engines Suzuki

| Articolo - Item | €/pc. | Art. POLIPODIO | Mod. | Mat. |
|-----------------|-------|----------------|---|------|
| L 81 44 014 | | SU007 | FM-24/S Original Code: 55125-94502 Motori HP 115 | ZN |

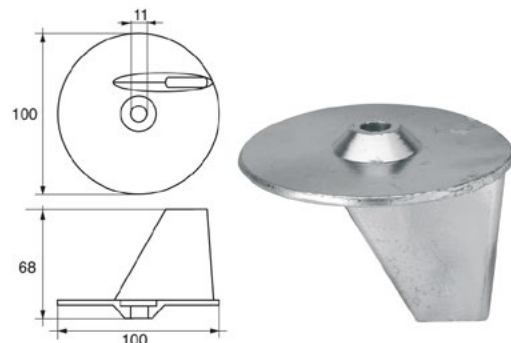

ANODI | ANODES

Anodo per motori
SuzukiAnode for engines
Suzuki

| Articolo - Item | €/pc. | Art. POLIPODIO | Mod. | Mat. |
|-----------------|-------|-------------------|---|------|
| L 81 44 002 | | SU008 | FM-30/S Original Code: 55320-98400 Motori HP 115 | ZN |

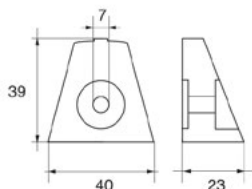
Anodo per motori
SuzukiAnode for engines
Suzuki

| Articolo - Item | €/pc. | Art. POLIPODIO | Mod. | Mat. |
|-----------------|-------|-------------------|--|------|
| L 81 44 006 | | SU009 | FM-31/S Original Code: 55321-93900 Motori HP 9,9-15 | ZN |

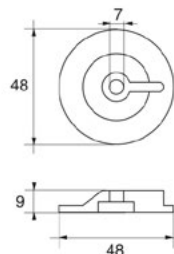
Anodi per motori
Volvo-PentaAnodes for engines
Volvo-Penta

| Articolo - Item | €/pc. | Art. POLIPODIO | Mod. | Mat. |
|-----------------|-------|-------------------|--------------------------------|------|
| L 81 40 010 | | VP001 | F-VP-100 Original Code: 875810 | ZN |
| L 82 40 010 | | VP001AL | Original Code: 875810 | AL |

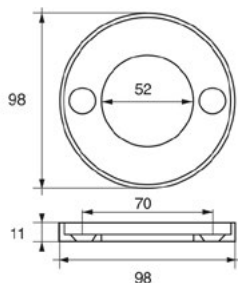
Anodi per motori
Volvo-PentaAnodes for engines
Volvo-Penta

| Articolo - Item | €/pc. | Art. POLIPODIO | Mod. | Mat. |
|-----------------|-------|-------------------|--------------------------------|------|
| L 81 40 020 | | VP002 | F-VP-200 Original Code: 875809 | ZN |
| L 82 40 020 | | VP002AL | Original Code: 875809 | AL |

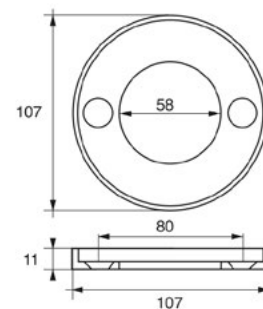
Anodi per motori
Volvo-PentaAnodes for engines
Volvo-Penta

| Articolo - Item | €/pc. | Art. POLIPODIO | Mod. | Mat. |
|-----------------|-------|-------------------|------------------------------------|------|
| L 81 40 027 | | VP003 | F-VP-250-270 Original Code: 875805 | ZN |
| L 82 40 027 | | VP003AL | Original Code: 875805 | AL |

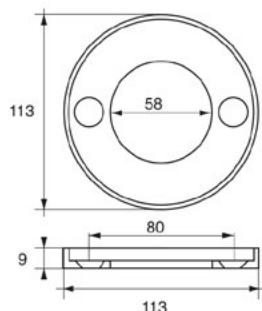
Anodi per motori
Volvo-PentaAnodes for engines
Volvo-Penta

| Articolo - Item | €/pc. | Art. POLIPODIO | Mod. | Mat. |
|-----------------|-------|-------------------|--------------------------------|------|
| L 81 40 028 | | VP004 | F-VP-280 Original Code: 875815 | ZN |
| L 82 40 028 | | VP004AL | Original Code: 875815 | AL |

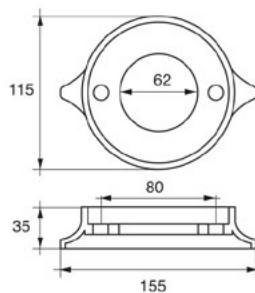

Anodi per motori Volvo-Penta

Anodes for engines Volvo-Penta

| Articolo - Item | €/pc. | Art. POLIPODIO | Mod. | Mat. |
|-----------------|-------|----------------|---|------|
| L 81 40 025 | | VP005 | F-VP/C Original Code: 875812 PIEDINO CORTO | ZN |
| L 82 40 025 | | VP005AL | Original Code: 875812 PIEDINO CORTO | AL |

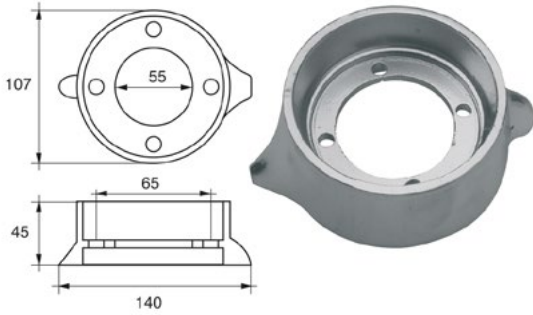

Anodi per motori Volvo-Penta

Anodes for engines Volvo-Penta

| Articolo - Item | €/pc. | Art. POLIPODIO | Mod. | Mat. |
|-----------------|-------|----------------|---|------|
| L 81 40 030 | | VP006B | F-VP DUE PROP Original Code: 852182 DUE PROP | ZN |
| L 82 40 030 | | VP006B/AL | Original Code: 852182 DUE PROP | AL |

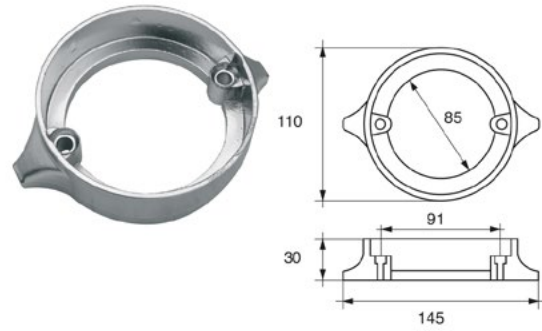

Anodi per motori Volvo-Penta

Anodes for engines Volvo-Penta

| Articolo - Item | €/pc. | Art. POLIPODIO | Mod. | Mat. |
|-----------------|-------|----------------|---|------|
| L 81 40 128 | | VP007 | P-VP Original Code: 832598 Serie 250-270-280 | ZN |
| L 82 40 128 | | VP007AL | Original Code: 832598 Serie 250-270-280 | AL |

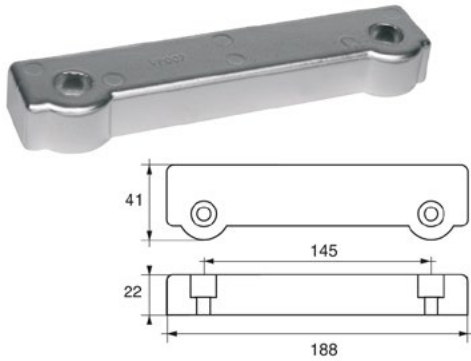

Anodi per motori Volvo-Penta

Anodes for engines Volvo-Penta

| Articolo - Item | €/pc. | Art. POLIPODIO | Mod. | Mat. |
|-----------------|-------|----------------|---|------|
| L 81 40 129 | | VP008 | F-VPT Original Code: 852835 DUE PROP | ZN |
| L 82 40 129 | | VP008AL | Original Code: 852835 DUE PROP | AL |

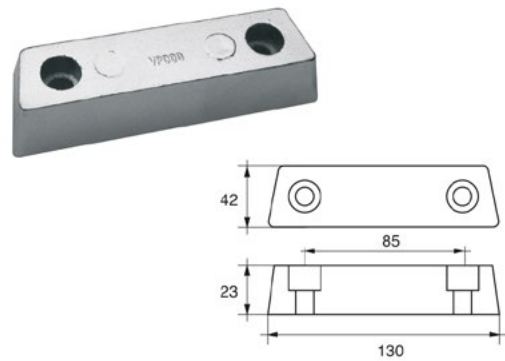

Anodi per motori Volvo-Penta

Anodes for engines Volvo-Penta

| Articolo - Item | €/pc. | Art. POLIPODIO | Mod. | Mat. |
|-----------------|-------|----------------|--------------------------------|------|
| L 81 40 000 | | VP009C | (Coppia) Original Code: 852018 | ZN |
| L 82 40 000 | | VP009C/AL | (Coppia) Original Code: 832598 | AL |

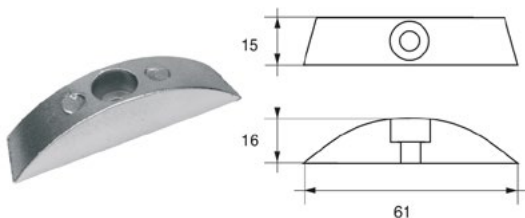

Anodi per motori Volvo-Penta

Anodes for engines Volvo-Penta

| Articolo - Item | €/pc. | Art. POLIPODIO | Mod. | Mat. |
|-----------------|-------|----------------|-------------------------------------|------|
| L 81 40 127 | | VP010 | F-VP TRIM 270 Original Code: 832934 | ZN |

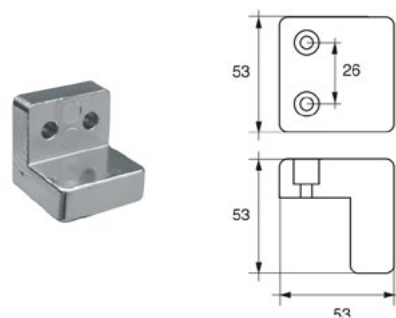

ANODI | ANODES

Anodo per motori Volvo-Penta

| Articolo - Item | €/pc. | Art. POLIPODIO | Mod. | Mat. |
|-----------------|-------|----------------|--------------------|------|
| L 81 40 136 | | VP015 | F-VPX-38 Serie DPX | ZN |

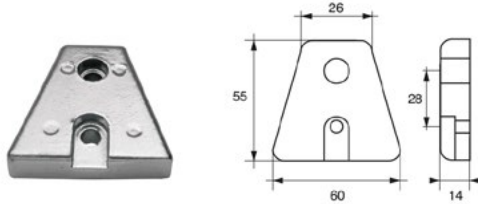

Anodes for engines Volvo-Penta

Anodi per motori Volvo-Penta

| Articolo - Item | €/pc. | Art. POLIPODIO | Mod. | Mat. |
|-----------------|-------|----------------|---|------|
| L 81 40 308 | | VP017 | F-VSX-11 con viti inox-with SS screws Original Code: 3855411 | ZN |
| L 82 40 308 | | VP017AL | Original Code: 3855411 | AL |

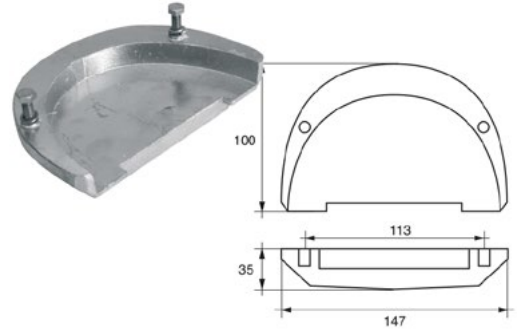

Anodes for engines Volvo-Penta

Anodi per motori Volvo-Penta

| Articolo - Item | €/pc. | Art. POLIPODIO | Mod. | Mat. |
|-----------------|-------|----------------|-------------------------------|------|
| L 81 40 135 | | VP012 | F-VP-35 Original Code: 872793 | ZN |
| L 82 40 135 | | VP012AL | Original Code: 872793 | AL |

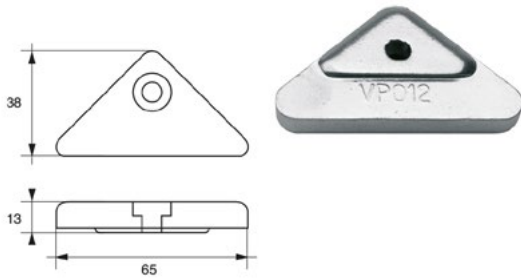

Anodes for engines Volvo-Penta

Anodi per motori Volvo-Penta

| Articolo - Item | €/pc. | Art. POLIPODIO | Mod. | Mat. |
|-----------------|-------|----------------|---|------|
| L 81 40 130 | | VP014 | F-VP-39 Original Code: 872139 Serie DPX | ZN |
| L 82 40 130 | | VP014AL | Original Code: 872139 Serie DPX | AL |

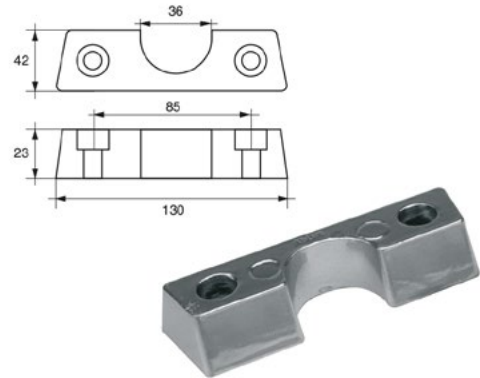

Anodes for engines Volvo-Penta

Anodi per motori Volvo-Penta

| Articolo - Item | €/pc. | Art. POLIPODIO | Mod. | Mat. |
|-----------------|-------|----------------|---|------|
| L 81 40 131 | | VP025 | F-VP-41 Original Code: 3588745 Serie DPH-DPR | ZN |
| L 82 40 131 | | VP025AL | Original Code: 3855411 Serie DPH-DPR | AL |

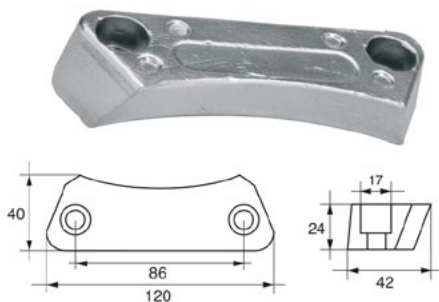

Anodes for engines Volvo-Penta

Anodi per motori Volvo-Penta

| Articolo - Item | €/pc. | Art. POLIPODIO | Mod. | Mat. |
|-----------------|-------|----------------|--|------|
| L 81 40 133 | | VP026 | Original Code: 3888305 Collare in due metà per piede Sail Drive | ZN |
| L 82 40 133 | | VP026AL | Original Code: 3888305 Collare in due metà per piede Sail Drive | AL |

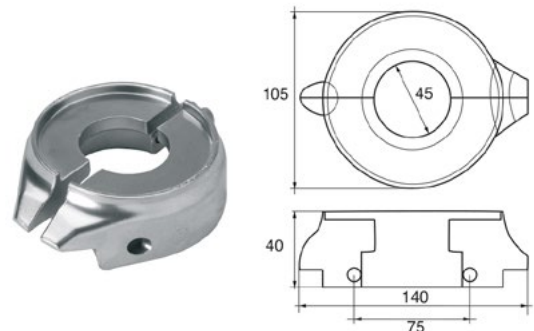

Anodes for engines Volvo-Penta

Anodi per motori Volvo-Penta

Anodes for engines Volvo-Penta

| Articolo - Item | €/pc. | Art. POLIPODIO | Mod. | Mat. |
|-----------------|-------|----------------|--|------|
| L 81 40 004 | | VP024 | F-VP-40 Original Code: 3588746 Serie DPH | ZN |
| L 82 40 004 | | VP024AL | Original Code: 3588746 Serie DPH | AL |

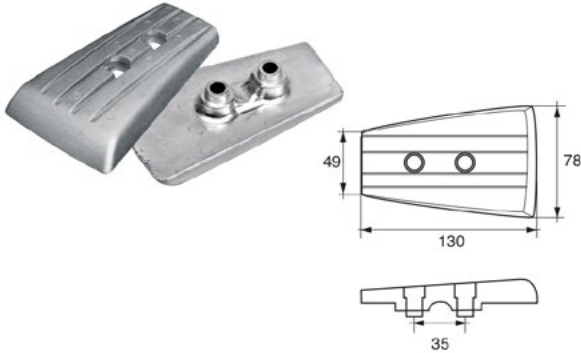

Anodi per motori Volvo-Penta

Anodes for engines Volvo-Penta

| Articolo - Item | €/pc. | Art. POLIPODIO | Mod. | Mat. |
|-----------------|-------|----------------|--|------|
| L 81 40 012 | | VP011 | F-VP-120/S Original Code: 876286 SEA DRIVE | ZN |
| L 82 40 012 | | VP011AL | Original Code: 876286 SEA DRIVE | AL |

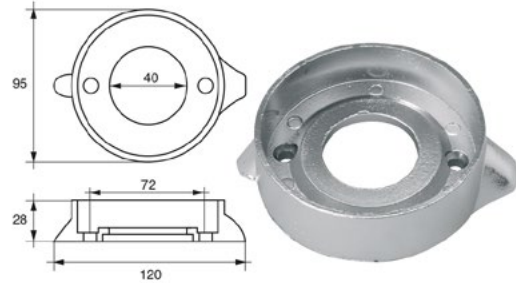

Anodi per motori Volvo-Penta

Anodes for engines Volvo-Penta

| Articolo - Item | €/pc. | Art. POLIPODIO | Mod. | A mm. | B mm. | C mm. | D mm. | Mat. |
|-----------------|-------|----------------|--------------------------|-------|-------|-------|-------|------|
| L 82 40 739 | | VP028 | Serie IPS O.C.: 40005875 | 270 | 85 | 30 | 140 | AL |

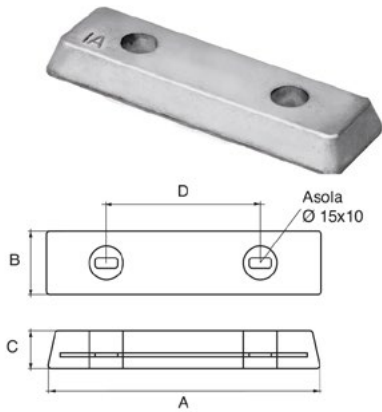

Anodi per motori Volvo-Penta

Anodes for engines Volvo-Penta

| Articolo - Item | €/pc. | Art. POLIPODIO | Mod. | Mat. |
|-----------------|-------|----------------|---|------|
| L 81 13 325 | | VP029 | Ogiva Asse Ø 25/30 3/4"UNC O.C.: 833913 | ZN |
| L 81 13 335 | | VP029A | Ogiva Asse Ø 35 7/8"UNC O.C.: 833915 | ZN |
| L 81 13 340 | | VP029B | Ogiva Asse Ø 40 1" UNC O.C.: 828140 | ZN |

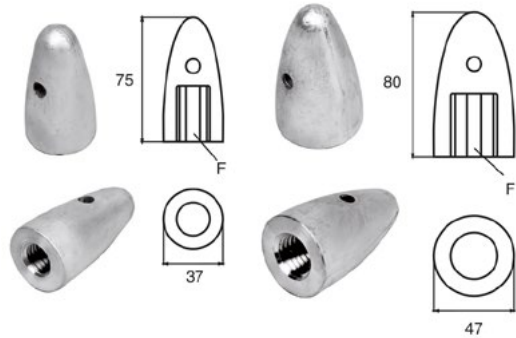

Anodi per motori Volvo-Penta

Anodes for engines Volvo-Penta

| Articolo - Item | €/pc. | Art. POLIPODIO | Mod. | Mat. |
|-----------------|-------|----------------|---|------|
| L 81 40 132 | | VP023 | Original Code: 3858399 Collare in 3 settori per eliche 3 pale | ZN |
| L 82 40 132 | | VP023AL | Original Code: 3858399 Collare in 3 settori per eliche 3 pale | AL |

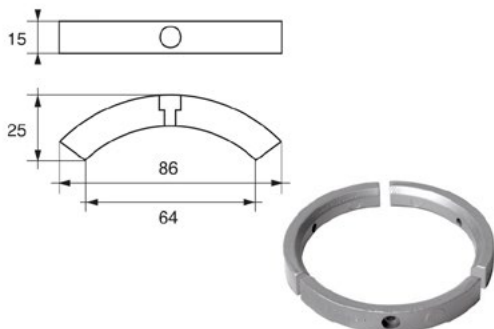

Anodi per motori Volvo-Penta

Anodes for engines Volvo-Penta

| Articolo - Item | €/pc. | Art. POLIPODIO | Mod. | Mat. |
|-----------------|-------|----------------|---------------------------------|------|
| L 81 40 082 | | VP016 | Original Code: 873395 Serie DPX | ZN |
| L 82 40 082 | | VP016AL | Original Code: 873395 Serie DPX | AL |

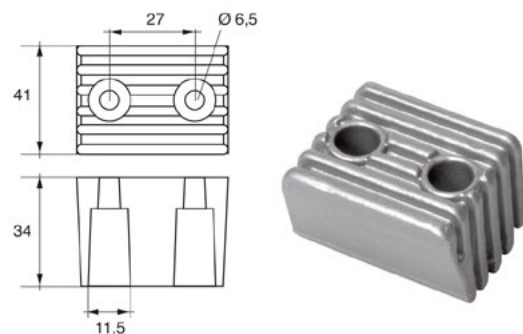

ANODI | ANODES

Anodi per motori Yamaha-Mariner

Anodes for engines Yamaha-Mariner

| Articolo - Item | €/pc. | Art. POLIPODIO | Mod. | Mat. |
|-----------------|-------|----------------|---|------|
| L 81 46 001 | | YA001 | FM-1M Original Code: 6794525100 Motori HP 40=60 MARINER dopo il 1991 | ZN |
| L 82 46 001 | | YA001AL | Original Code: 6794525100 Motori HP 40=60 MARINER dopo il 1991 | AL |

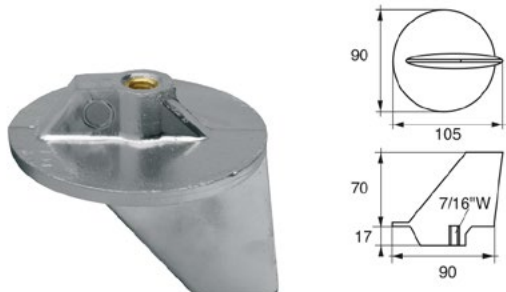

Anodi per motori Yamaha-Mariner

Anodes for engines Yamaha-Mariner

| Articolo - Item | €/pc. | Art. POLIPODIO | Mod. | Mat. |
|-----------------|-------|----------------|--|------|
| L 81 46 006 | | YA004 | FM-YA 60/90 Original Code: 668-45371-02 Motori HP 60-90 | ZN |
| L 82 46 006 | | YA004AL | Original Code: 668-45371-02 Motori HP 60-90 | AL |

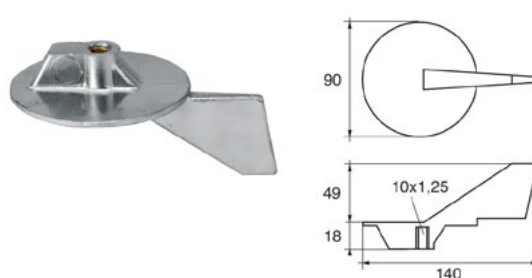

Anodi per motori Yamaha-Mariner

Anodes for engines Yamaha-Mariner

| Articolo - Item | €/pc. | Art. POLIPODIO | Mod. | Mat. |
|-----------------|-------|----------------|---|------|
| L 81 46 003 | | YA006 | FM-3M Original Code: 664-45371-01 Motori HP 20-25-30-70 YAMAHA | ZN |

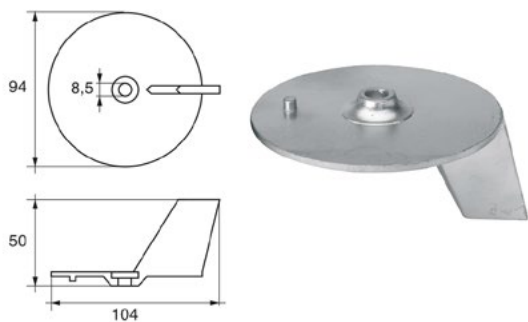

Anodi per motori Yamaha-Mariner

Anodes for engines Yamaha-Mariner

| Articolo - Item | €/pc. | Art. POLIPODIO | Mod. | Mat. |
|-----------------|-------|----------------|--|------|
| L 81 46 004 | | YA006B | Original Code: 67C-45371-00 Motori HP 10-50 MARINER | ZN |
| L 82 46 004 | | YA006BAL | Original Code: 67C-45371-00 Motori HP 10-50 MARINER | AL |

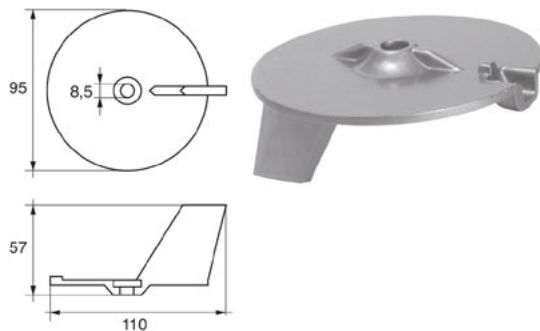

Anodo per motori Yamaha-Mariner

Anode for engines Yamaha-Mariner

| Articolo - Item | €/pc. | Art. POLIPODIO | Mod. | Mat. |
|-----------------|-------|----------------|---|------|
| L 81 46 016 | | YA007 | F-YA 60/90 Original Code: 6H4-45251-01 Motori HP 60=90 | ZN |

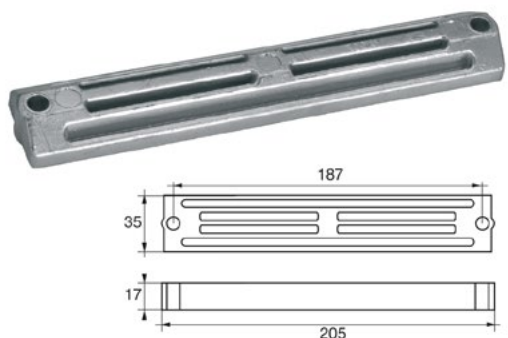

Anodi per motori Yamaha-Mariner

Anodes for engines Yamaha-Mariner

| Articolo - Item | €/pc. | Art. POLIPODIO | Mod. | Mat. |
|-----------------|-------|----------------|---|------|
| L 81 46 015 | | YA010 | F-YA-115 Original Code: 6G5-45251-02 Motori HP 115=225 | ZN |
| L 82 46 015 | | YA010AL | Original Code: 6G5-45251-02 Motori HP 115=225 | AL |

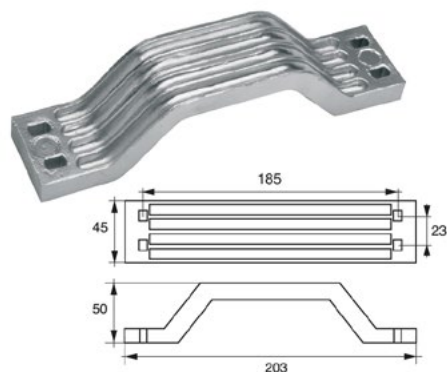

**Anodi per motori
Yamaha-Mariner**

**Anodes for engines
Yamaha-Mariner**

| Articolo - Item | €/pc. | Art. POLIPODIO | Mod. | Mat. |
|-----------------|-------|-------------------|--|------|
| L 81 46 022 | | YA011 | FM-YA-115 Original Code: 6E5-45371-01 Motori HP 115÷225 | ZN |
| L 82 46 022 | | YA011AL | Original Code: 6E5-45371-01 Motori HP 115÷225 | AL |

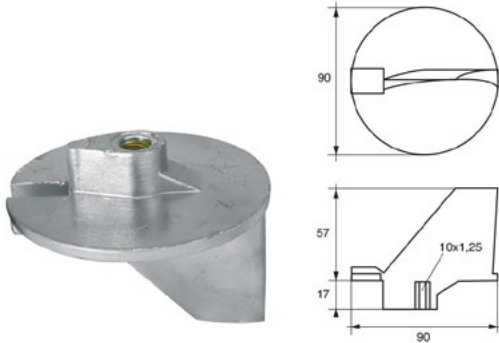

**Anodi per motori
Yamaha-Mariner**

**Anodes for engines
Yamaha-Mariner**

| Articolo - Item | €/pc. | Art. POLIPODIO | Mod. | Mat. |
|-----------------|-------|-------------------|--|------|
| L 81 46 105 | | YA014 | F-YA-16 Original Code: 6E5-45251-00 Motori HP 115÷225 | ZN |
| L 82 46 105 | | YA014AL | Original Code: 6E5-45251-00 Motori HP 115÷225 | AL |

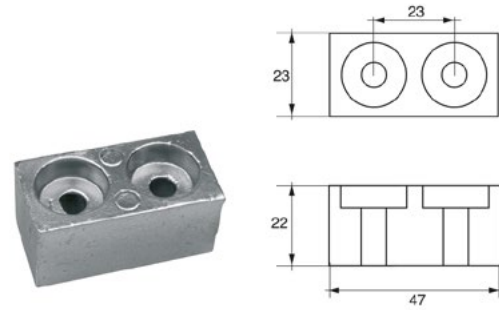

**Anodi per motori
Yamaha-Mariner**

**Anodes for engines
Yamaha-Mariner**

| Articolo - Item | €/pc. | Art. POLIPODIO | Mod. | Mat. |
|-----------------|-------|-------------------|--|------|
| L 81 46 116 | | YA020 | F-YA-22 Original Code: 6E8-45251 Motori HP 9,9-15 | ZN |

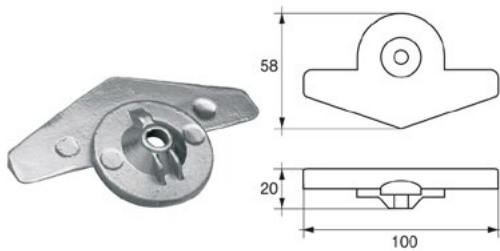

**Anodi per motori
Yamaha-Mariner**

**Anodes for engines
Yamaha-Mariner**

| Articolo - Item | €/pc. | Art. POLIPODIO | Mod. | Mat. |
|-----------------|-------|-------------------|---|------|
| L 81 46 024 | | YA021 | F-YA-225 R Original Code: 6J9-45371-02 Motori HP 220 | ZN |
| L 82 46 024 | | YA021AL | Original Code: 6J9-45371-02 Motori HP 220 | AL |

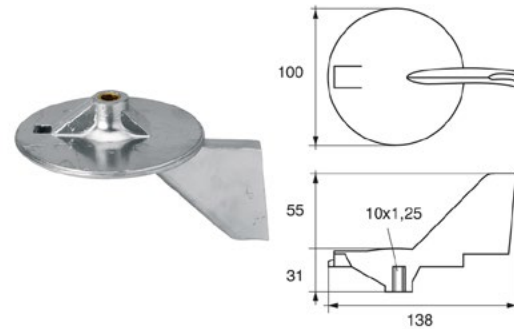

**Anodi per motori
Yamaha-Mariner**

**Anodes for engines
Yamaha-Mariner**

| Articolo - Item | €/pc. | Art. POLIPODIO | Mod. | Mat. |
|-----------------|-------|-------------------|---|------|
| L 81 46 023 | | YA022 | FM-YA-225 L O.C.: 6J9-45371-01 Motori HP 220 | ZN |
| L 82 46 023 | | YA022AL | Original Code: 6J9-45371-01 Motori HP 220 | AL |

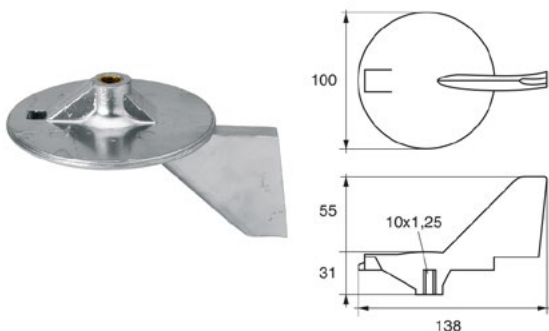

**Anodo per motori
Yamaha-Mariner**

**Anode for engines
Yamaha-Mariner**

| Articolo - Item | €/pc. | Art. POLIPODIO | Mod. | Mat. |
|-----------------|-------|-------------------|--|------|
| L 81 46 118 | | YA016 | F-YA-18 Original Code: 6N0-65251-00 YAMAHA 6C-6D-8C | ZN |

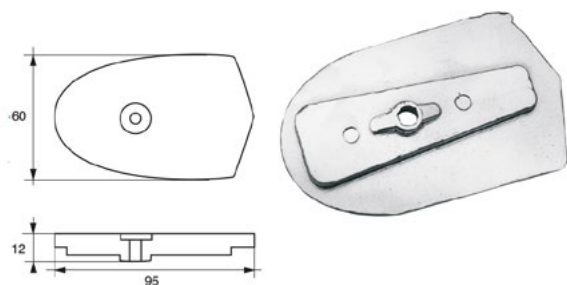

ANODI | ANODES

Anodo per motori Yamaha-Mariner

| Articolo - Item | €/pc. | Art. POLIPODIO | Mod. | Mat. |
|-----------------|-------|----------------|---|------|
| L 81 46 117 | | YA017 | F-YA-19 Original Code: 6L5-45251-02 Motori HP 3,5 YAMAHA | ZN |

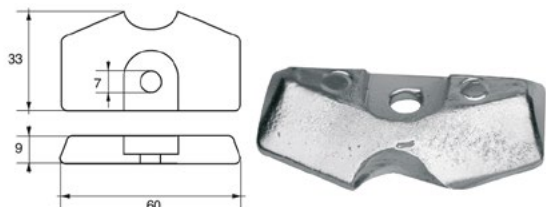

Anodes for engines Yamaha-Mariner

Anodi per motori Yamaha-Mariner

| Articolo - Item | €/pc. | Art. POLIPODIO | Mod. | Mat. |
|-----------------|-------|----------------|--|------|
| L 81 46 115 | | YA019 | F-YA-21 Original Code: 6H1-45251-02 Motori HP 25÷75 | ZN |
| L 82 46 115 | | YA019AL | Original Code: 6H1-45251-02 Motori HP 25÷75 | AL |

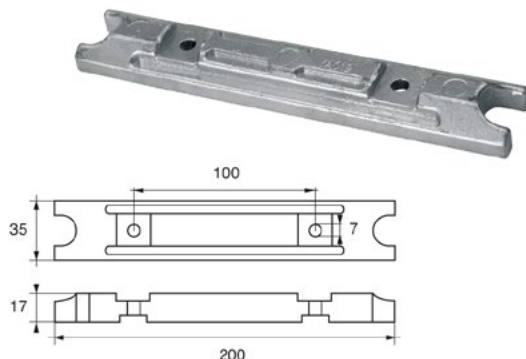

Anodi per motori Yamaha-Mariner

| Articolo - Item | €/pc. | Art. POLIPODIO | Mod. | Mat. |
|-----------------|-------|----------------|--|------|
| L 81 46 304 | | YA030 | F-YA-28 Original Code: 63D-45251-10 Motori HP 40-50 2T-4T | ZN |
| L 82 46 304 | | YA030AL | F-YA-28AL Original Code: 63D-45251-10 Motori HP 40-50 2T-4T | AL |

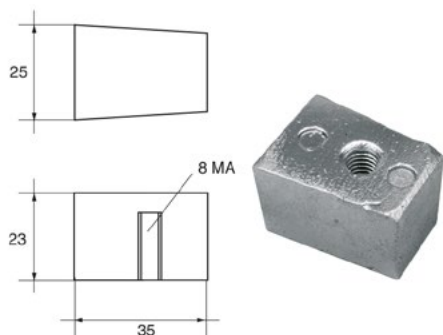

Anodes for engines Yamaha-Mariner

Anodi per motori Yamaha-Mariner

| Articolo - Item | €/pc. | Art. POLIPODIO | Mod. | Mat. |
|-----------------|-------|----------------|---|------|
| L 81 46 303 | | YA032 | F-YA-30 Original Code: 61N-45251-01 Motori F-25 4T | ZN |
| L 82 46 303 | | YA032AL | F-YA-30AL Original Code: 61N-45251-01 Motori F-25 4T | AL |

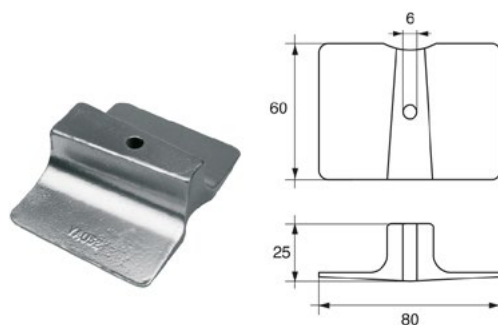

Anodi per motori Yamaha-Mariner

| Articolo - Item | €/pc. | Art. POLIPODIO | Mod. | Mat. |
|-----------------|-------|----------------|--|------|
| L 81 46 301 | | YA033 | F-YA-31 Original Code: 61W-45251-00 Motori F-25 4T TRIM | ZN |
| L 82 46 301 | | YA033AL | Original Code: 61W-45251-00 Motori F-25 4T TRIM | AL |

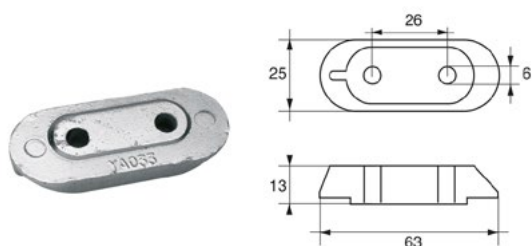

Anodes for engines Yamaha-Mariner

Anodi per motori Yamaha-Mariner

| Articolo - Item | €/pc. | Art. POLIPODIO | Mod. | Mat. |
|-----------------|-------|----------------|--|------|
| L 81 46 302 | | YA041 | Original Code: 61A-45371-00 Pinna direzionale | ZN |
| L 82 46 302 | | YA041AL | Original Code: 6L9-45371-00 Pinna direzionale | AL |

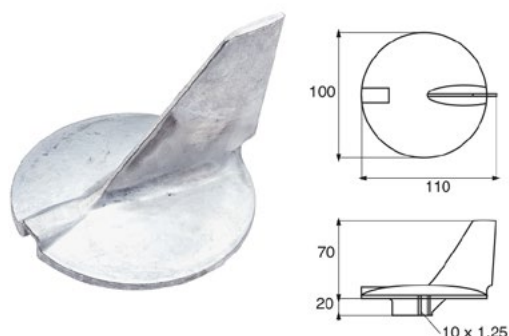

Anodo per motori
Yamaha-Mariner

Anode for engines
Yamaha-Mariner

| Articolo - Item | €/pc. | Art. POLIPODIO | Mod. | Mat. |
|-----------------|-------|-------------------|--|------|
| L 81 46 025 | | YA042 | MOTORI Original Code: 6E5-45371-10 Motori HP 60-225 | ZN |

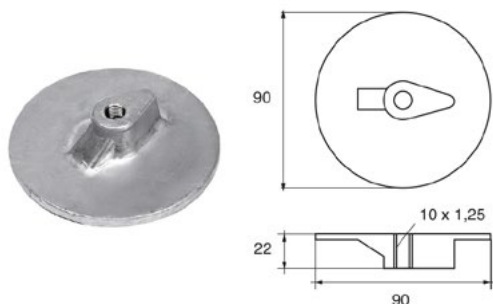

Anodo per motori
Yamaha-Mariner

Anode for engines
Yamaha-Mariner

| Articolo - Item | €/pc. | Art. POLIPODIO | Mod. | Mat. |
|-----------------|-------|-------------------|--|------|
| L 81 46 306 | | YA037 | F-YA-37 Original Code: 67F-45371-00 Motori HP 100 4T Serie 80 | ZN |

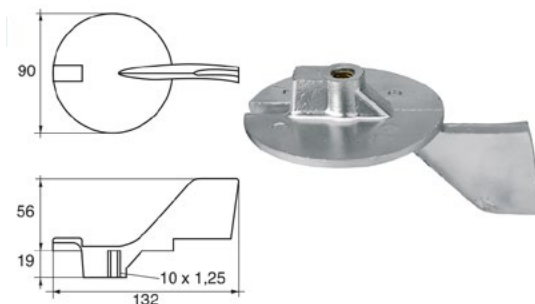

follow us    www.trem.net

IL FUTURO È ELETTRICO

THE FUTURE IS ELECTRIC



- + ECONOMICA
INEXPENSIVE
- + PULITA
CLEAN
- + ECOLOGICA
ECOLOGICAL
- + LEGGERA
LIGHT
- + FACILE DA INSTALLARE
EASY INSTALLATION
- + ELEGANTE
STYLISH
- + MODERNA
MODERN

KIT ANODI IN ALLUMINIO | ALUMINIUM ANODES KIT

Kit Mercury Verado 4/Optimax

In alluminio.

Mercury Verado 4/Optimax kit

Manufactured in aluminium.

Articolo - Item €/pc.

L 82 48 004



| RIF. ORIGINALE ORIGINAL REF. | Qty |
|------------------------------|-----|
| 818298 | 1 |
| 826134 | 2 |
| 762145 | 1 |

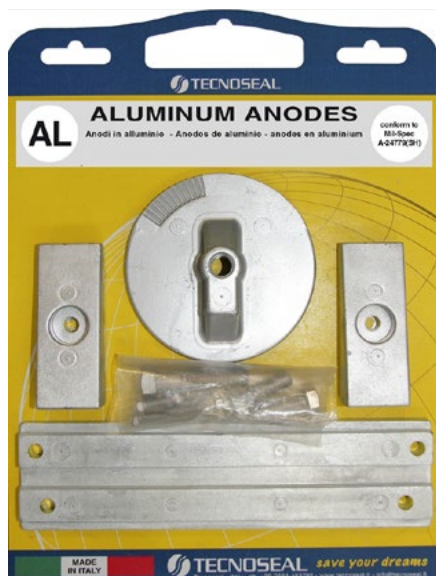

Kit Mercury Verado 6

In alluminio.

Mercury Verado 6 kit

Manufactured in aluminium.

Articolo - Item €/pc.

L 82 48 006



| RIF. ORIGINALE ORIGINAL REF. | Qty |
|------------------------------|-----|
| 880653 | 1 |
| 892227 | 4 |
| 826134 | 2 |
| 762145 | 1 |

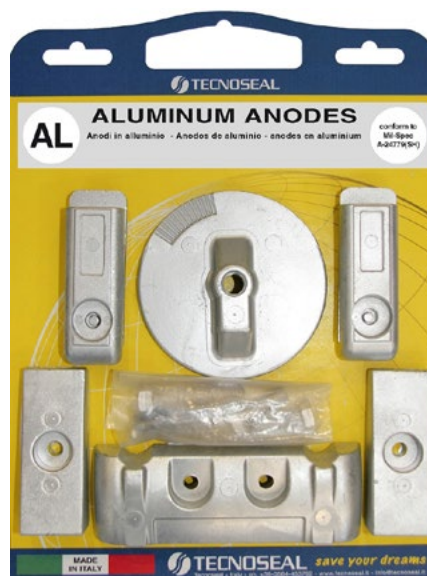

Kit Mercruiser

BRAVO II dal 1989 e BRAVO III dal 1989 al 2003.

Mercruiser kit

BRAVO II after 1989 and BRAVO III from 1989 to 2003.

Articolo - Item €/pc.

L 82 43 003



| RIF. ORIGINALE ORIGINAL REF. | Qty |
|------------------------------|-----|
| 762145 | 1 |
| 821630 | 1 |
| 806190 | 2 |

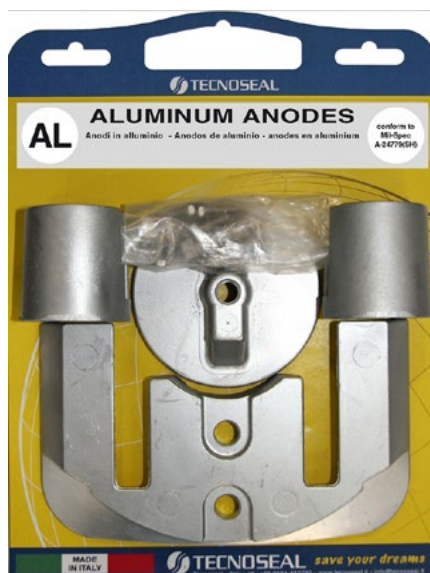

Kit Mercruiser

ALPHA I GENERATION dal 1991.

Mercruiser kit

ALPHA I GENERATION after 1991.

Articolo - Item €/pc.

L 82 43 991



| RIF. ORIGINALE ORIGINAL REF. | Qty |
|------------------------------|-----|
| 762145 | 1 |
| 806105 | 1 |
| 821629 | 1 |
| 821631 | 1 |
| 806189 | 2 |

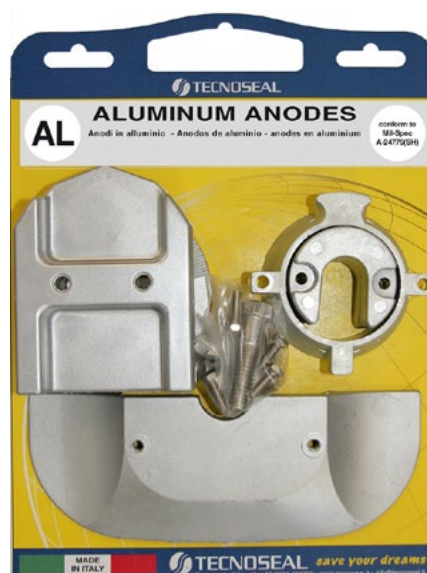

KIT ANODI IN ALLUMINIO | ALUMINIUM ANODES KIT

Kit Mercruiser

BRAVO III dal 2004.

Mercruiser kit

BRAVO III after 2004.

Articolo - Item €/pc.

L 82 43 004



| RIF. ORIGINALE ORIGINAL REF. | Qty |
|------------------------------|-----|
| 761244 | 1 |
| 762145 | 1 |
| 865182C | 1 |
| 821630 | 1 |
| 806190 | 2 |



Kit Mercruiser

ALPHA I GENERATION I dal 1983 al 1990.

Mercruiser kit

ALPHA I GENERATION I from 1983 to 1990.

Articolo - Item €/pc.

L 82 43 983



| RIF. ORIGINALE ORIGINAL REF. | Qty |
|------------------------------|-----|
| 31640 | 1 |
| 55989 | 2 |
| 821631 | 1 |



Kit Mercruiser

BRAVO I dal 1988.

Mercruiser kit

BRAVO I after 1988.

Articolo - Item €/pc.

L 82 43 968



| RIF. ORIGINALE ORIGINAL REF. | Qty |
|------------------------------|-----|
| 762145 | 1 |
| 806188 | 1 |
| 821630 | 1 |
| 806190 | 2 |

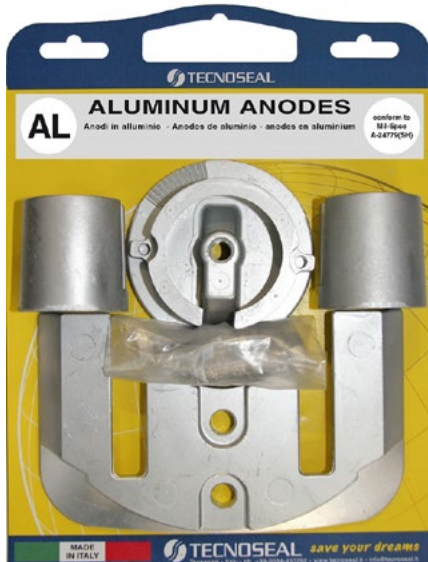

Kit Yamaha 150-200 HP

Outboard.

Yamaha 150-200 HP kit

Outboard.

Articolo - Item €/pc.

L 82 46 233



| RIF. ORIGINALE ORIGINAL REF. | Qty |
|------------------------------|-----|
| 6G54525101 | 1 |
| 6J94537101 | 1 |

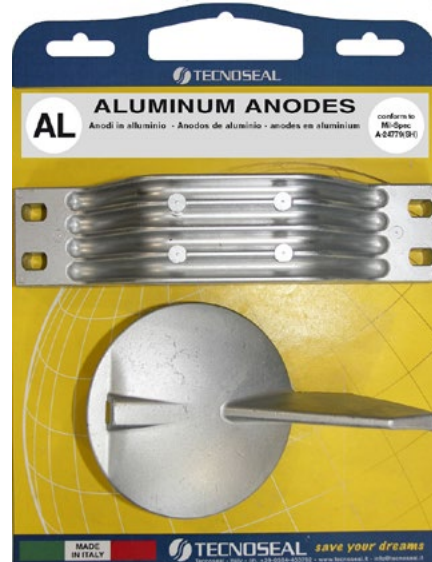

KIT ANODI IN ALLUMINIO | ALUMINIUM ANODES KIT

Kit Yamaha 150-200 HP

Outboard-Controrotante.

Yamaha 150-200 HP kit

Outboard.

Articolo - Item €/pc.

L 82 46 234



| RIF. ORIGINALE ORIGINAL REF. | Qty |
|---------------------------------|-----|
| 6G54525101 | 1 |
| 6K14537102 | 1 |

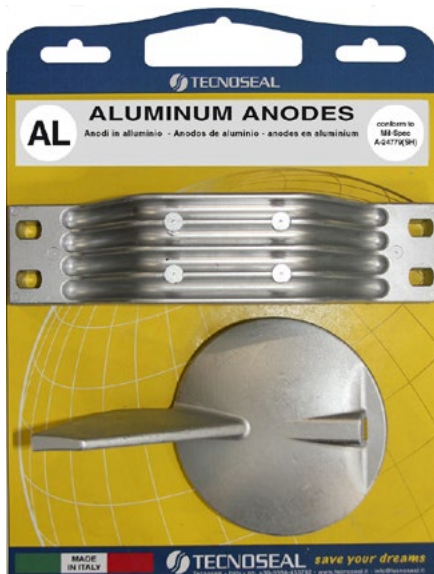

Kit Yamaha 200-250 HP

Outboard.

Yamaha 200-250 HP kit

Outboard.

Articolo - Item €/pc.

L 82 46 250



| RIF. ORIGINALE ORIGINAL REF. | Qty |
|---------------------------------|-----|
| 6G54525101 | 1 |
| 61A4537100 | 1 |

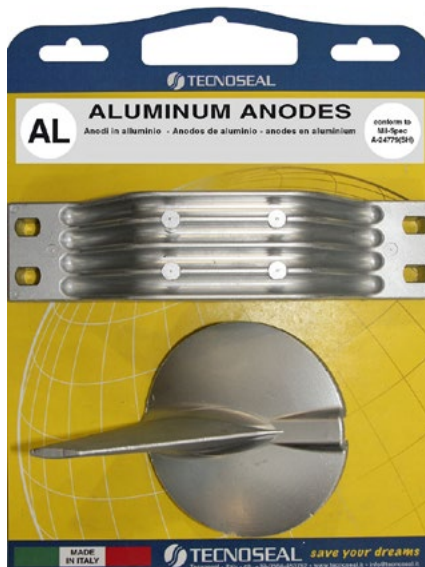

Kit Suzuki 40 HP

Outboard.

Suzuki 40 HP kit

Outboard.

Articolo - Item €/pc.

L 82 44 040



| RIF. ORIGINALE ORIGINAL REF. | Qty |
|---------------------------------|-----|
| 55320-95310 | 1 |
| 55321-87J00 | 1 |
| 565320-98600 | 1 |

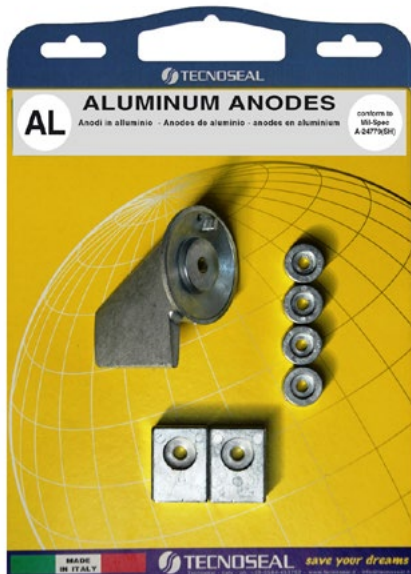

Kit Yamaha 40-60 HP 4T

Outboard.

Yamaha 40-60 HP 4T kit

Outboard.

Articolo - Item €/pc.

L 82 46 060



| RIF. ORIGINALE ORIGINAL REF. | Qty |
|---------------------------------|-----|
| 65W-45251-00 | 3 |
| 67C-45251-00 | 1 |
| 67C-45371-00 | 1 |

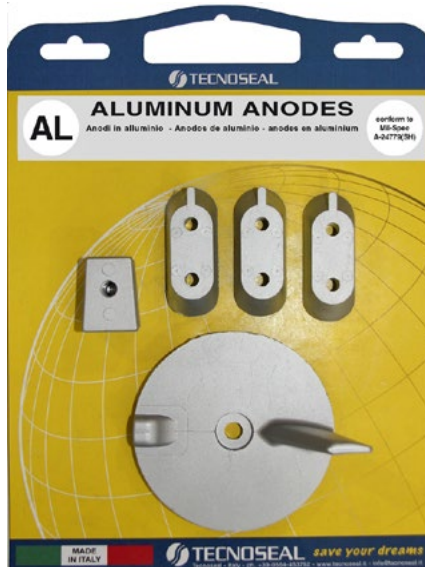

VISIT OUR NEW WEB SITE



WWW.TREM.NET



PIASTRE DI POPPA | TRANSOM PROTECTIVE PLATES

Piastra proteggi poppa

Realizzata in PVC flessibile, per davanti e dietro. Può essere utilizzata anche come antivibrante. Modello universale.

Transom protective plate

Manufactured in flexible PVC, front and back. Also suitable as antivibration device. Universal size.

| Articolo - Item | €/pc. | Colore-Colour | ↑ mm. |
|-----------------|-------|---------------|---------|
| N 00 28 040 | | ■ Grigio-Grey | 400x280 |

**Piastra proteggi poppa**

Realizzata in alluminio con anello di sicurezza salvamotore.

Transom protective plate

Manufactured in aluminium, complete with motor-protection safety ring.

| Articolo - Item | €/pc. | ↑ mm. |
|-----------------|-------|---------------------------|
| N 00 79 305 | | 316x100 (oltre-over 10HP) |

**Piastra proteggi poppa in plastica zigrinata**

Realizzata in alluminio con anello di sicurezza salvamotore.

Knurled plastic stern protection plate

Manufactured in aluminium, complete with motor-protection safety ring.

| Articolo - Item | €/pc. | Articolo - Item | €/pc. | Versione-Version | ↑ mm. | Spessore-Width mm. |
|-----------------|-------|-----------------|-------|--|---------|--------------------|
| - | | N 00 10 027 | | Interna-Internal | 270x100 | 5 |
| N 00 74 030 | | - | | Esterna tender-External tender | 300x220 | 5 |
| O 05 03 043 | | - | | Esterna con asola-External with slot | 450x360 | 3 |
| O 05 20 043 | | O 05 80 043 | | A cuneo per variare l'inclinazione del motore Wedge-shaped to adjust engine inclination | 420x340 | 22÷1 |
| N 00 74 043 | | - | | Esterna-External | 450x360 | 5 |



made by



N0010027



N0074030



N0074043

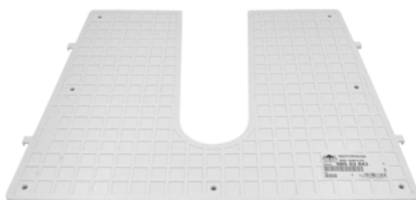

O0503043



O0520043-O0580043



Supporto motore per fissaggio a parete

Guance in acciaio inox lucidato, tavola in faggio verniciato. Regolabile in tre posizioni. Regolazione: 0-17°.

Outboard motor bracket for transom mounting

Polished stainless steel block cheeks, lacquered beech wood board. Adjustable in three positions (0-17°).

| Articolo - Item | €/pc. | Portata Max load kg. | Per motori For engines | A mm. | B mm. | C mm. |
|-----------------|-------|----------------------|------------------------|-------|-------|-------|
| O 07 00 250 | | 40 | up to 12HP | 200 | 286 | 195 |

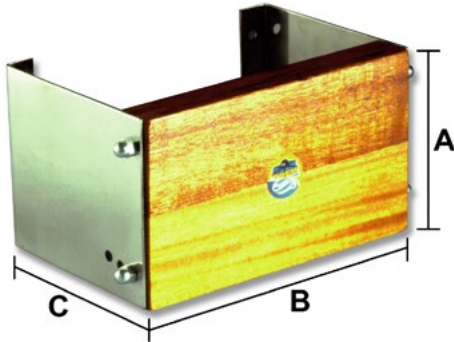

Supporto motore regolabile per fissaggio sul piano

Fissaggio su piano con spalle in acciaio inox lucidato e tavola in compensato marino di mogano. Realizzato per imbarcazioni con plancetta di poppa dell'ultima generazione. Fissaggio sul lato superiore della plancetta. Regolazione: 0-17°.

Adjustable outboard bracket for deck-mounting

Deck mounting with polished stainless steel sides, marine mahogany plywood board. Designed for boats with the latest generation transom shape. For mounting on the upper navigating bridge side. Adjustable 0-17°.

| Articolo - Item | €/pc. | Portata Max load kg. | Per motori For engines | A mm. | B mm. | C mm. |
|-----------------|-------|----------------------|------------------------|-------|-------|-------|
| S 30 00 275 | | 40 | up to 12HP | 200 | 285 | 195 |

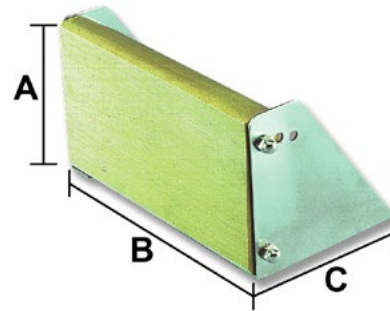

Supporto motore per fissaggio a parete

Spalle in acciaio inox e tavola in compensato marino di mogano.

Outboard motor bracket for transom mounting

Polished stainless steel sides and marine mahogany plywood board.

| Articolo - Item | €/pc. | Portata Max load kg. | Per motori For engines | A mm. | B mm. | C mm. |
|-----------------|-------|----------------------|------------------------|-------|-------|-------|
| O 07 00 275 | | 40 | up to 12HP | 215 | 195 | 190 |

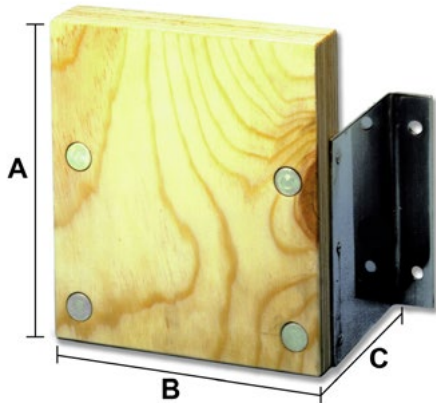

Tavoletta portamotore per pulpito

Fabbricata in plastica bianca. Portamotore max 10HP. Adatta per tubi Ø 22-25 mm. Fissaggio al pulpito di poppa.

Motor bracket for tender

Manufactured in white plastic. Max bracket 10HP. Suitable for tubes Ø 22-25 mm. Suitable for fastening on the rail of the transom.

| Articolo - Item | €/pc. | mm. | Portata Max load kg. | Per motori For engines |
|-----------------|-------|---------|----------------------|------------------------|
| O 07 45 003 | | 175x165 | 30 | up to 10HP |



SUGGESTED ITEM

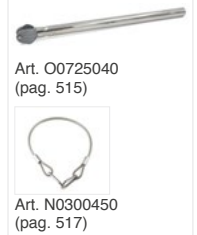

Si consiglia di collegare il motore con il cavo di sicurezza Pag. 517
It is recommended to connect the engine with the safety cable. Pag. 517

Tubo

Realizzato in acciaio inox per tavoletta portamotore.

Pipe

Manufactured in stainless steel for motor bracket.

| Articolo - Item | €/pc. | Lunghezza-Length mm. | Ø mm. |
|-----------------|-------|----------------------|-------|
| O 07 25 040 | | 430 | 25 |



SUGGESTED ITEM



Tavoletta portamotore per pulpito

Tavoletta in compensato marino verniciato ai poliuretani. Tubo con forcella in acciaio inox. Dotato di doppi fori per adattare il supporto ai pulpiti con tubi Ø 22-25-30 mm.

Motor bracket for tender

Polyurethane coated marine plywood board. Stainless steel fork pipe. Equipped with two holes to adapt the brackets onto pulpit pipe Ø 22-25-30 mm.

| Articolo - Item | €/pc. | mm. | Tavoletta Board mm. | Portata Max load kg. | Per motori For engines |
|-----------------|-------|----------|---------------------|----------------------|------------------------|
| O 07 20 032 | | Ø 25x430 | 200x250 | 30 | up to 10HP |

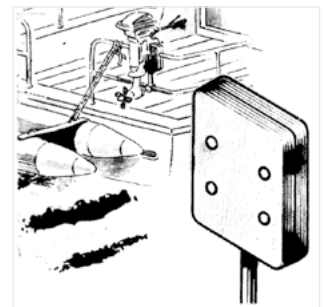

COMPLETE WITH



SUPPORTI MOTORE | OUTBOARD MOTOR BRACKETS

Supporto motore a ribalta

Fabbricato in alluminio. Tavoletta in compensato di mogano verniciato. Regolabile a 4 posizioni. Molle e viteria Aisi 316.

| Articolo - Item | €/pc. | Portata | A | B | C | D | E |
|-----------------|-------|--------------|-----|-----|-----|-----|-----|
| | | Max load kg. | mm. | mm. | mm. | mm. | mm. |
| O 05 00 369 | | 30 | 200 | 240 | 35 | 189 | 100 |

made by  **ALLUMINIUM**

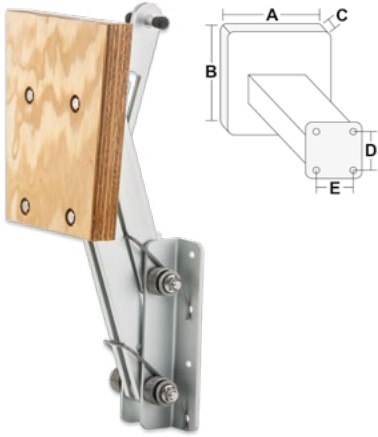

SUGGESTED ITEM

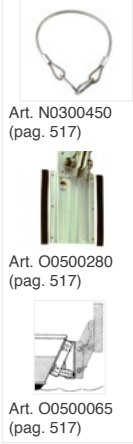

Adjustable outboard motor bracket

Manufactured in aluminium. Painted mahogany plywood board. Adjustable in 4 positions. Aisi 316 springs and screws.

Supporto motore a ribalta

Fabbricato in alluminio. Tavoletta in compensato di mogano verniciato. Regolabile a 4 posizioni. Molle e viteria Aisi 316.

| Articolo - Item | €/pc. | Portata | A | B | C | D | E |
|-----------------|-------|--------------|-----|-----|-----|-----|-----|
| | | Max load kg. | mm. | mm. | mm. | mm. | mm. |
| O 05 00 420 | | 35 | 200 | 260 | 45 | 189 | 90 |

made by  **ALLUMINIUM**

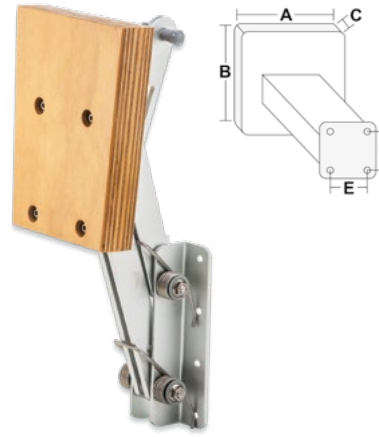

SUGGESTED ITEM



Adjustable outboard motor bracket

Manufactured in aluminium. Painted mahogany plywood board. Adjustable in 4 positions. Aisi 316 springs and screws.

Supporto motore a ribalta

Fabbricato in alluminio. Tavoletta in plastica di altissima resistenza, inalterabile nel tempo. Regolabile a 4 posizioni. Molle e viteria Aisi 316.

| Articolo - Item | €/pc. | Portata | A | B | C | D | E |
|-----------------|-------|--------------|-----|-----|-----|-----|-----|
| | | Max load kg. | mm. | mm. | mm. | mm. | mm. |
| O 05 79 429 | | 35 | 190 | 290 | 45 | 189 | 100 |

made by  **ALLUMINIUM**

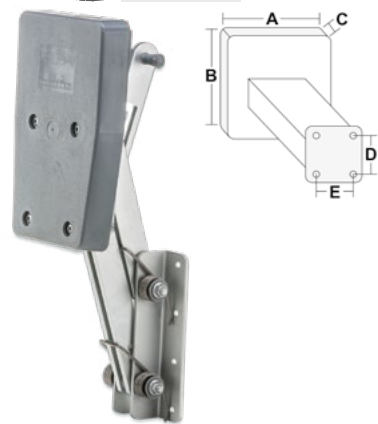

SUGGESTED ITEM

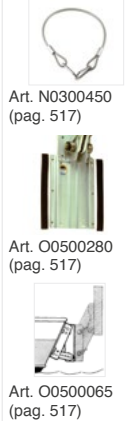

Adjustable outboard motor bracket

Manufactured in aluminium. High resistance plastic board, unalterable over time. Adjustable in 4 positions. Aisi 316 springs and screws.

Supporto motore a ribalta

Fabbricato in alluminio. Tavoletta in compensato di mogano verniciato. Regolabile a 5 posizioni. Molle e viteria Aisi 316.

| Articolo - Item | €/pc. | Portata | A | B | C | D | E |
|-----------------|-------|--------------|-----|-----|-----|-----|-----|
| | | Max load kg. | mm. | mm. | mm. | mm. | mm. |
| O 05 00 480 | | 40 | 260 | 300 | 45 | 189 | 135 |

made by  **ALLUMINIUM**



SUGGESTED ITEM

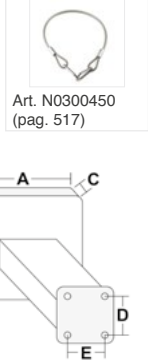

Adjustable outboard motor bracket

Manufactured in aluminium. Painted mahogany plywood board. Adjustable in 5 positions. Aisi 316 springs and screws.

Supporto motore a ribalta

Fabbricato in alluminio. Tavoletta in legno di mogano verniciato. Regolabile a 4 posizioni. Molle e viteria Aisi 316.

| Articolo - Item | €/pc. | Portata | A | B | C | D | E |
|-----------------|-------|--------------|-----|-----|-----|-----|-----|
| | | Max load kg. | mm. | mm. | mm. | mm. | mm. |
| O 05 00 450 | | 40 | 260 | 300 | 45 | 189 | 135 |

made by  **ALLUMINIUM**



SUGGESTED ITEM



Adjustable outboard motor bracket

Manufactured in aluminium. Painted mahogany wood board. Adjustable in 4 positions. Aisi 316 springs and screws.

Supporto motore a ribalta

Fabbricato in alluminio. Tavoletta in legno di mogano verniciato. Regolabile a 4 posizioni. Realizzata a doppio telaio. Molle e viteria Aisi 316.

| Articolo - Item | €/pc. | Portata | A | B | C | D | E |
|-----------------|-------|--------------|-----|-----|-----|-----|-----|
| | | Max load kg. | mm. | mm. | mm. | mm. | mm. |
| O 05 70 480 | | 50 | 300 | 300 | 45 | 189 | 230 |

made by  **ALLUMINIUM**



SUGGESTED ITEM



Adjustable outboard motor bracket

Manufactured in aluminium. Painted mahogany wood board. Adjustable in 4 positions. Made with a double frame. Aisi 316 springs and screws.

Supporti motore a ribalta AISI 316

Realizzati in acciaio inox lucidati a specchio. Funzionamento a ribalta con possibilità di regolazione intermedia per mezzo di una comoda maniglia. Supporti ad alta resistenza, inalterabili nel tempo. Design accurato.

Adjustable outboard motor brackets AISI 316

Manufactured in mirror polished stainless steel. Drop-down system with intermediate adjustment by means of a comfortable handle. Equipped with a highly-resistant pad. Durable over time. Fine design.

| Articolo - Item | €/pc. | Per motori fino a For engines up to | Tavoletta Board | Posizioni Positions | A mm. | B mm. | C mm. | D mm. | E mm. |
|-----------------|-------|--|--------------------|------------------------|----------|----------|----------|----------|----------|
| O 08 10 239 | | 8HP / 30 kg. | Legno-Wood | 4 | 205 | 240 | 35 | 110 | 85 |
| O 08 15 390 | | 15HP / 40 kg. | Legno-Wood | 4 | 205 | 260 | 45 | 110 | 115 |
| O 08 20 479 | | 20HP / 40 kg. | Legno-Wood | 5 | 200 | 265 | 45 | 110 | 115 |
| O 08 19 239 | | 8HP / 30 kg. | Plastica-Plastic | 4 | 190 | 290 | 45 | 110 | 80 |
| O 08 29 479 | | 15HP / 40 kg. | Plastica-Plastic | 4 | 190 | 290 | 45 | 110 | 115 |

AISI 316



SUGGESTED ITEM

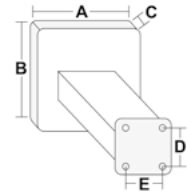

Supporti motore ausiliario «Mega»

Realizzato completamente in acciaio inox. Modello di grande robustezza.

Auxiliary outboard motor bracket «Mega»

Manufactured in stainless steel. Very sturdy model.

| Articolo - Item | €/pc. | Per motori fino a For engines up to | Escursione verticale Vertical excursion mm. | Misure tavola portamotore Board mm. | Piastra di supporto Support plate mm. | Regolazione inclinazione tavoletta Adjusting board inclination |
|-----------------|-------|--|--|---|--|---|
| O 08 10 479 | | 20HP (2T)-8HP (4T) / 40 kg. | 290 | 265H-210 Larghezza-Width 45 Spessore-Thickness | 190x200 | da-da from 0° a-a to 28° +/- |

AISI 316



SUGGESTED ITEM



Guida supporti motore

Fabbricata in alluminio anodizzato. Permette di sfilare il supporto dall'imbarcazione.

Plate for motor bracket

Manufactured in anodised aluminium. It allows to remove the motor bracket.

| Articolo - Item | €/pc. |
|-----------------|-------|
| O 05 00 280 | |

AISI 316



Piastra regolabile supporti motore

Fabbricata in alluminio anodizzato. Permette di fissare il supporto su specchio di poppa positivo o negativo. Regolabile da 5° a 30°.

Adjustable plate for motor bracket

Manufactured in anodised aluminium. It allows to fix the motor bracket on transom with positive or negative inclination. Adjustable 5-30°.

| Articolo - Item | €/pc. |
|-----------------|-------|
| O 05 00 065 | |

AISI 316

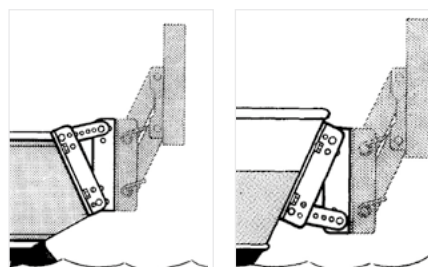

Cavetto di sicurezza Safety cable

Fabbricato in acciaio inox rivestito in plastica. Munito di un moschettoni inox alle estremità, per motori fuoribordo.

Manufactured in plastic covered stainless steel. Supplied with a stainless steel spring hook at the ends. For outboard engines.

| Articolo - Item | €/pc. | Lunghezza Length mm. | Portata Max load kg. |
|-----------------|-------|-------------------------|-------------------------|
| N 03 00 450 | | 600 | 120 |





Cavalletto porta motore

Realizzato in tubo di acciaio zincato, con tavoletta in faggio evaporato e verniciato ai poliuretani.

Outboard engine trolley

Manufactured in zinc plated steel pipes and polyurethane lacquered evaporated beech board.

| Articolo - Item | €/pc. | Tubo-Pipe Ø mm. | Larghezza tavoletta Board width mm. | H mm. | Per motori For engines | Portata Max load kg. |
|-----------------|-------|-----------------|-------------------------------------|-------|--|----------------------|
| O 09 38 008 | | 22 | 430 | 900 | Ad albero lungo-Long shaft up to 25 HP (2T) / 15 HP (4T) | 70 |



Cavalletto porta motore

Realizzato in tubo di acciaio zincato, con tavoletta in compensato fenolico.

Outboard engine trolley

Manufactured in zinc plated steel pipes and phenolic plywood board.

| Articolo - Item | €/pc. | Tubo-Pipe Ø mm. | Larghezza tavoletta Board width mm. | H mm. | Per motori For engines | Portata Max load kg. |
|-----------------|-------|-----------------|-------------------------------------|-------|--|----------------------|
| O 09 40 100 | | 40 | 450 | 1000 | Ad albero lungo-Long shaft up to 200 HP (2T) / 150 HP (4T) | 200 |



Cavalletto porta motore

Realizzato in tubo di acciaio zincato, con tavoletta in compensato fenolico.

Outboard engine trolley

Manufactured in zinc plated steel pipes and phenolic plywood board.

| Articolo - Item | €/pc. | Tubo-Pipe Ø mm. | Larghezza tavoletta Board width mm. | H mm. | Per motori For engines | Portata Max load kg. |
|-----------------|-------|-----------------|-------------------------------------|-------|--|----------------------|
| O 09 00 007 | | 22 | 430 | 900 | Ad albero lungo-Long shaft up to 15 HP (2T) / 10 HP (4T) | 50 |



CAVALLETTI SUPPORTO MOTORE CON RUOTE | ENGINE HOLDING TROLLEYS WITH WHEELS



Cavalletto porta motore

Realizzato in tubo di acciaio zincato, con ruote e porta serbatoio. Tavoletta in faggio evaporato e verniciato ai poliuretani. Completo di elastico ferma serbatoio.

Outboard engine trolley

Manufactured in zinc plated steel pipes and phenolic plywood board. With wheels and elastic tank holder.

| Articolo - Item | €/pc. | Tubo-Pipe Ø mm. | Larghezza tavoletta Board width mm. | H mm. | Per motori For engines | Portata Max load kg. |
|-----------------|-------|-----------------|-------------------------------------|-------|-------------------------------|----------------------|
| O 08 00 012 | | 25 | 430 | 900 | up to 30 HP (2T) / 20 HP (4T) | 70 |



COMPLETE WITH

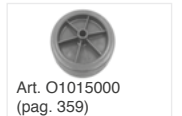

Cavalletto porta motore pieghevole

Realizzato completamente in acciaio zincato, con ruote pneumatiche da 6" Ø 260 mm. Tavoletta in compensato fenolico verniciato ai poliuretani.

Folding outboard engine trolley

Fully manufactured in zinc plated steel. With 6" pneumatic wheels Ø 260 mm. Phenolic lacquered evaporated plywood board.

| Articolo - Item | €/pc. | Tubo-Pipe Ø mm. | Larghezza tavoletta Board width mm. | H mm. | Per motori For engines | Portata Max load kg. |
|-----------------|-------|-----------------|-------------------------------------|-------|-------------------------------|----------------------|
| O 08 26 090 | | 25 | 430 | 1000 | up to 30 HP (2T) / 20 HP (4T) | 70 |



COMPLETE WITH SUGGESTED ITEM

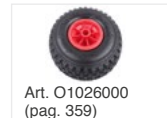

Cavalletto porta motore pieghevole

Realizzato completamente in acciaio zincato. Con ruote in nylon e gomma, completo di porta serbatoio. Tavola in compensato fenolico verniciato ai poliuretani. Ruote Ø 360 mm.

Folding outboard engine trolley

Fully manufactured in zinc plated steel. Complete with nylon and rubber wheels, it includes a tank-holder. Phenolic lacquered evaporated plywood board. Wheels Ø 360 mm.

| Articolo - Item | €/pc. | Tubo-Pipe Ø mm. | Larghezza tavoletta Board width mm. | H mm. | Per motori For engines | Portata Max load kg. |
|-----------------|-------|-----------------|-------------------------------------|-------|---------------------------------|----------------------|
| O 08 36 095 | | 25 | 450 | 1050 | up to 150 HP (2T) / 115 HP (4T) | 100 |



COMPLETE WITH SUGGESTED ITEM

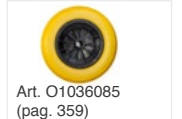
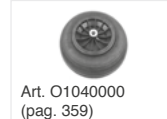

Barra prolunga di guida

Fabbricato in alluminio anodizzato. Particolari in Nylon 66 caricati a fibra di vetro.

Extension rod for outboard engines

Manufactured in anodised aluminium. Fibreglass and Nylon 66 parts.

| Articolo - Item | €/pc. | Lunghezza Length mm. | Pulsante spegnimento Power off button | Mod. |
|-----------------|-------|----------------------|---------------------------------------|--------------|
| N 40 00 350 | | 700 | NO | Fisso-Steady |
| N 40 30 070 | | 700 | SI-YES | Fisso-Steady |
| N 41 30 120 | | 600-1000 | SI-YES | Telescopic |

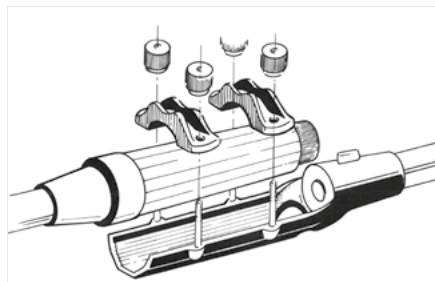
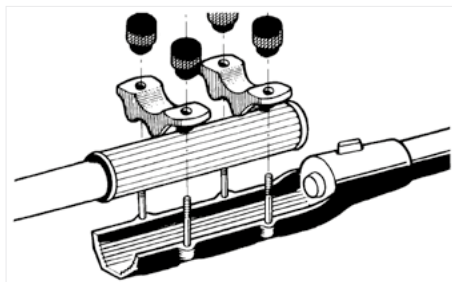
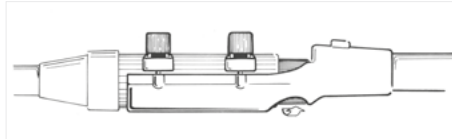

Provvista di morsetto universale, per il fissaggio su qualsiasi tipo di impugnatura del motore fuoribordo. Capovolgendo i morsetti è possibile stringere manopole di diametro molto piccolo.

Equipped with universal clamp for fastening on all models of outboard motor handles. Reversing the clamps it's possible to tighten very small diameter grips.

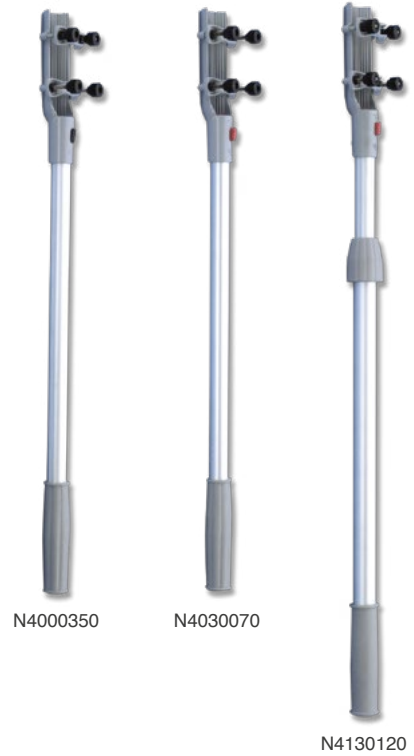

N4000350

N4030070

N4130120

ANTIFURTO | MARINE ANTITHEFT DEVICES

Antifurto per motori fuoribordo

Fabbricato in acciaio inox Aisi 316. Completo di lucchetto in ottone.

Antitheft device for outboard motors

Manufactured in Aisi 316 stainless steel. Complete with brass padlock.

| Articolo - Item | €/pc. | Tubo-Pipe Ø mm. | Lunghezza-Length mm. |
|-----------------|-------|-----------------|----------------------|
| N 02 00 240 | | 30 | 240 |
| N 02 00 450 | | 30 | 320 |
| N 02 00 900 | | 40 | 320 |

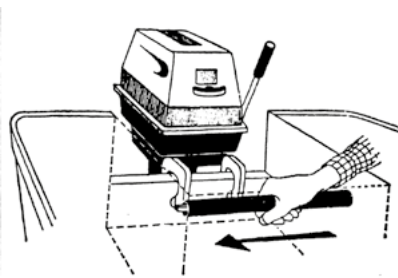

COMPLETE WITH

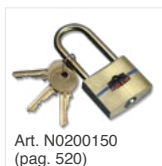

Art. N0200150 (pag. 520)



N0200240

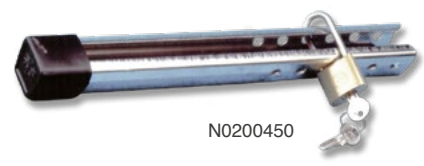

N0200450



N0200900

Antifurto in acciaio inox

Fabbricato in tubo di acciaio inox.

Antitheft device for outboard motors

Manufactured in Aisi 316 stainless steel. Complete with brass padlock.

| Articolo - Item | €/pc. | mm. | kg. |
|-----------------|-------|--------|-------|
| N 02 71 118 | | 305x40 | 0,800 |





Lucchetti in ottone cromato

Corpo in ottone cromato anticorrosione. Arco e molle in acciaio inox. Contropistoncini antigrimaldello.

Chromed brass padlocks

Body in anti-corrosion chromed brass. Arch and springs in stainless steel.

| Articolo - Item | €/pc. | Arco-Arch mm. | kg. |
|-----------------|-------|---------------|-------|
| N 02 18 030 | | 30x18 | 0,180 |
| N 02 24 040 | | 40x24 | 0,200 |
| N 02 29 050 | | 50x29 | 0,220 |



Lucchetto in ottone con arco inox

Particolarmente robusto e resistente. Munito di chiavi in ottone cromato. Modello adatto per portazattera.

Brass padlock with stainless steel arch

Very strong padlock. With key in chromed brass. Suitable for liferaft.

| Articolo - Item | €/pc. | Arco-Arch mm. | kg. |
|-----------------|-------|---------------|-------|
| N 02 00 030 | | 30x20 | 0,130 |



Lucchetto arco lungo in ottone

Particolarmente robusto e resistente. Munito di chiavi in ottone cromato.

Padlock with long arch in brass

Very strong padlock. With key in chromed brass.

| Articolo - Item | €/pc. | Arco-Arch mm. | kg. |
|-----------------|-------|---------------|-------|
| N 02 00 150 | | 50x34 | 0,150 |



Kit 5 lucchetti

Lucchetti fabbricati in ottone lucidato. Kit dotato di una sola coppia di chiavi che li apre tutti.

Kit of 5 padlocks

Manufactured in polished brass. With key suitable for all of them.

| Articolo - Item | €/Kit | Arco-Arch mm. | kg. |
|-----------------|-------|---------------|-------|
| N 02 18 005 | | 30x18 | 0,180 |



Lucchetti «Abus Marine»

| Articolo - Item | €/pc. |
|-----------------|-------|
| N 02 32 130 | |
| N 02 32 131 | |

Padlocks «Abus Marine»

| mm. |
|--------|
| 49x74 |
| 49x112 |



PAGAIE E REMI | PADDLES & OARS

Pagaie smontabili per canoa e kayak

Realizzate in alluminio anodizzato. Pala in ABS.

Removable canoe/kayak paddles

Manufactured in anodised aluminium with ABS pole.

| Articolo - Item | €/pc. | Lunghezza Length cm. | Manico-Handle Ø mm. | Caratteristiche tecniche Technical features |
|-----------------|-------|----------------------|---------------------|---|
| R 27 00 213 | | 210 | 25 | Smontabile in 2 pezzi It can be disassembled into 2 pcs. |
| R 27 00 244 | | 250 | 25 | Smontabile in 2 pezzi It can be disassembled into 2 pcs. |



Pagaie per canoa

Realizzate in alluminio anodizzato. Pala in ABS.

Canoe paddles

Manufactured in anodised aluminium with ABS pole.

| Articolo - Item | €/pc. | Lunghezza Length cm. | Manico-Handle Ø mm. | Mod. |
|-----------------|-------|----------------------|---------------------|---------------------------------|
| R 27 31 150 | | 150 | 25 | Semplice-Simple |
| R 27 19 220 | | 210 | 30 | Doppia pala 90°-Double pole 90° |
| R 27 77 210 | | 210 | 35 | Doppia pala 90°-Double pole 90° |



Pagaie con pala in ABS bianco e gancio d'accosto in nylon terminale

Manico in alluminio. Modello molto robusto e funzionale.

Paddles with white ABS blade and nylon boat hook handle

Aluminium handle. Very functional and sturdy model.

| Articolo - Item | €/pc. | Lunghezza Length cm. | Manico-Handle Ø mm. | Mod. | Pala Blade |
|-----------------|-------|----------------------|---------------------|------------------------|------------|
| R 10 25 160 | | 150 | 25 | Fisso-Steady | |
| R 10 74 080 | | 80-114 | 22-25 | Telescopico Mini | |
| R 10 25 120 | | 120-200 | 22-25 | Telescopico-Telescopic | |
| R 10 30 190 | | 125-190 | 28-30 | Telescopico-Telescopic | |



COMPLETE WITH



Pagaie d'emergenza tritelescopiche

Manico in alluminio. Pala in plastica.

Telescopic emergency paddles

Aluminium handle. Plastic blade.

| Articolo - Item | €/pc. | Lunghezza Length cm. | Manico-Handle Ø mm. | Mod. |
|-----------------|-------|----------------------|---------------------|-----------------------------|
| R 20 50 130 | | 55-107 | 22-25 | Con impugnatura-With handle |
| R 20 28 110 | | 55-130 | 22-25 | Con impugnatura-With handle |
| R 10 28 110 | | 55-130 | 22-25 | Gancio d'accosto-Boat hook |



PAGAIE E REMI | PADDLES & OARS

Remetti in alluminio

Fabbricati in tubo di alluminio.
Provvisi di pala in materia plastica.

Aluminium paddles

Manufactured in anodized aluminium pipe.
Provided with plastic blade.

| Articolo - Item | €/pc. | Mod. | Lunghezza | | Ø mm. |
|-----------------|-------|----------------------|-----------|-----|-------|
| | | | Length | cm. | |
| R 20 25 110 | | Con anello-With ring | 110 | 25 | |
| R 20 25 125 | | Con anello-With ring | 125 | 25 | |
| R 10 79 160 | | Con gancio-With hook | 160 | 25 | |



COMPLETO DI-COMLETE WITH

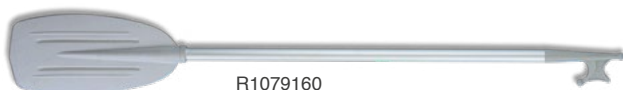

Mini remo telescopico

Con pala in plastica, impugnatura in gomma e tubo in alluminio anodizzato.

Mini telescopic paddle

With plastic blade, rubber handle and anodized aluminium pipe.

| Articolo - Item | €/pc. | Lunghezza-Length cm. | | Ø mm. |
|-----------------|-------|----------------------|-----|-------|
| | | MIN | MAX | |
| R 20 25 030 | | 66 | 90 | 25 |



COMPLETO DI-COMLETE WITH



Remi smontabili in alluminio anodizzato

Con pala in plastica nera, impugnatura in gomma. Versione con i due spezzoni simili quando smontati.

Removable anodized aluminium paddles

With black plastic blade, rubber handle. Version with two similar slugs when disassembled.

| Articolo - Item | €/pc. | Lunghezza-Length cm. | | | Ø mm. |
|-----------------|-------|----------------------|------------|---------------|-------|
| | | Totale-Full | Pala-Blade | Manico-Handle | |
| R 16 35 160 | | 160 | 92 | 75 | 35 |
| R 16 35 180 | | 180 | 102 | 85 | 35 |



SUGGESTED ITEM

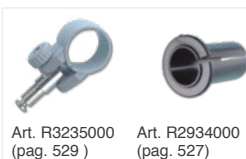

COMPLETO DI-COMLETE WITH



Remi in alluminio anodizzato

Con pala in plastica nera, impugnatura in gomma.

Anodized aluminium paddles

With black plastic blade, rubber handle.

| Articolo - Item | €/pc. | Lunghezza-Length cm. | | Ø mm. |
|-----------------|-------|----------------------|-----|-------|
| | | MIN | MAX | |
| R 10 35 165 | | 165 | 35 | |
| R 10 80 180 | | 180 | 35 | |



SUGGESTED ITEM



COMPLETO DI-COMLETE WITH

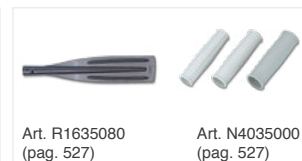

Remi divisibili in 2 pezzi per gommoni

Pala antiurto in plastica grigia, manico in alluminio anodizzato argento.

Assembling oars for inflatable boats

Impact-resistant grey plastic blade, aluminium anodized silver pole.

| Articolo - Item | €/pc. | Lunghezza-Length cm. | | | Ø mm. | Colore Colour |
|-----------------|-------|----------------------|------------|---------------|-------|---------------|
| | | Totale-Full | Pala-Blade | Manico-Handle | | |
| R 16 80 150 | | 150 | 55 | 100 | 35 | Black |
| R 16 79 150 | | 150 | 55 | 100 | 35 | Grey |



SUGGESTED ITEM



COMPLETE WITH

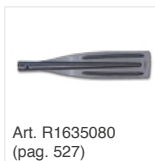

Remo smontabile telescopico con gancio d'accosto

Pala antiurto in plastica, manico alluminio anodizzato argento.

Removable telescopic oar with boat hook

Impact-resistant plastic blade, silver anodized aluminium pole.

| Articolo - Item | €/pc. | Lunghezza-Length cm. | | Ø mm. |
|-----------------|-------|----------------------|-----|-------|
| | | MIN | MAX | |
| R 16 28 180 | | 80 | 180 | 30/35 |



COMPLETO DI-COMLETE WITH



REMI E PAGAIE | WOODEN OARS & PADDLES

Remi in legno

Realizzati in robustissimo abete. Verniciati a specchio ai poliuretani. Provvisti di gironi.

Wooden oars

Manufactured in very sturdy fir wood. Glass lacquered polyurethane.

| Articolo - Item | €/pc. | Mod. | Lunghezza Length cm. | Manico-Handle Ø mm. | Gironi Ø est. |
|-----------------|-------|-------------------------|-------------------------|------------------------|------------------|
| R 13 38 200 | | Pala piatta-Flat blade | 200 | 36 | 43 |
| R 13 38 220 | | Pala piatta-Flat blade | 220 | 36 | 43 |
| R 14 46 260 | | Pala curva-Curved blade | 260 | 46 | 54 |



SUGGESTED ITEM



SCALMI-ROWLOCKS
(pag. 528)

Remo smontabile per canotti

Realizzato in faggio con giunto a scatto in acciaio inox. Molto robusto e di ottima finitura.

Jointed oar for dinghy

Manufactured in beech wood, with stainless steel snap-on joint. Very sturdy, fine quality.

| Articolo - Item | €/pc. | Lunghezza-Length cm. | Ø mm. |
|-----------------|-------|----------------------|-------|
| R 15 35 150 | | 153 | 36 |



SUGGESTED ITEM



SCALMI-ROWLOCKS
(pag. 528)

Pagaia in legno laminato

Verniciata a specchio ai poliuretani, con impugnatura anatomica.

Laminated wood paddle

Mirror lacquered polyurethane coating, with anatomic handle.

| Articolo - Item | €/pc. | Lunghezza-Length cm. |
|-----------------|-------|----------------------|
| R 26 00 140 | | 145 |

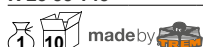

Nota: altre misure e colori a richiesta (min. 10 pz.)
Note: further sizes and colours available for min. 10 pcs.)



MEZZI MARINAI | BOAT HOOKS

Mezzo marinaio fisso in alluminio

Robustissimo, forma superiore appiglia-sporgenza. Manico in alluminio anodizzato con manopola in gomma terminale.

Aluminium steady boat hook

Very sturdy grip, anodized aluminium pole with rubber handle.

| Articolo - Item | €/pc. | Lunghezza Length cm. | Manico-Handle Ø mm. | Gancio di ricambio Spare handle |
|-----------------|-------|-------------------------|------------------------|------------------------------------|
| R 00 25 135 | | 130 | 25 | |
| R 00 25 165 | | 160 | 25 | |
| R 01 30 180 | | 180 | 30 | |
| R 01 30 210 | | 210 | 30 | |



COMPLETO DI-COMLETE WITH



GANCI
HOOKS
(pag.527)



MANOPOLE
HANDLES
(pag.527)

Mezzo marinaio fisso in legno

Manico in legno verniciato a specchio.

Wooden steady boat hook

Glass lacquered wooden handle.

| Articolo - Item | €/pc. | Lunghezza Length cm. | Manico-Handle Ø mm. | Gancio di ricambio Spare handle |
|-----------------|-------|-------------------------|------------------------|------------------------------------|
| R 03 30 180 | | 180 | 30 | |
| R 03 30 210 | | 210 | 30 | |
| R 03 36 240 | | 240 | 36 | |



COMPLETE WITH



GANCI-HOOKS
(pag. 527)

Mezzo marinaio telescopico in alluminio

Gancio in nylon, manico in alluminio anodizzato e manopola terminale in gomma. Leggero e galleggiante, si può regolare in tutte le posizioni volute, per mezzo di apposito bloccaggio a ghiera (il sistema più sicuro al mondo).

Aluminium telescopic boat hook

Nylon hook, anodized aluminium pole and rubber handle. Light model, it floats, adjustable in all positions by means of a ring lockin system (the most secure system in the world).

| Articolo - Item | €/pc. | Mod. | Lunghezza-Length min/max cm. | Tubi-Poles Ø mm. |
|-----------------|-------|-----------|------------------------------|------------------|
| R 00 25 130 | | SKIPPER | 100/200 | 25/22 |
| R 00 30 135 | | ADMIRAL | 120/210 | 30/27 |
| R 00 35 130 | | COMMODORE | 120/210 | 35/32 |

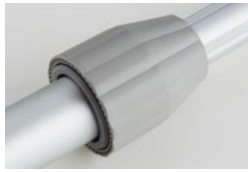

COMPLETO DI-COMLETE WITH



GANCI HOOKS (pag.527)

MANOPOLE HANDLES (pag.527)

Mezzo marinaio telescopico con gancio in alluminio

Completamente in alluminio anodizzato naturale, compreso il gancio. Provvisto di speciale sistema di bloccaggio che ne consente l'arresto in qualsiasi posizione. Con doppia impugnatura.

Telescopic boat hook with aluminium hook

Fully manufactured in anodised aluminium, hook included. Equipped with a special locking device allowing to stop the hook in any position. Complete with a double handle.

| Articolo - Item | €/pc. | Lunghezza-Length min/max cm. | Tubo-Pole Ø mm. |
|-----------------|-------|------------------------------|-----------------|
| R 04 30 112 | | 112/195 | 25/30 |



COMPLETE WITH



Art. N4030000 (pag. 527)

Mezzo marinaio telescopico «Sailor»

Realizzato in alluminio anodizzato, con gancio in nylon e doppia manopola. Molto robusto, si può bloccare in qualsiasi posizione, tramite la speciale rotazione. Essendo inverso, è l'unico mezzo marinaio che non rischia mai di bloccarsi con la salsedine. Si apre e si chiude senza togliere le mani dall'impugnatura.

Telescopic boat hook «Sailor»

Manufactured in anodized aluminium, with nylon hook and a double handle. Very sturdy, it can be stopped in any position by means of a special rotation system. It is the only boat hook that never risks getting stuck with salt. It opens and closes without removing the hands from the handle.

| Articolo - Item | €/pc. | Lunghezza-Length min/max cm. | Tubo-Pole Ø mm. |
|-----------------|-------|------------------------------|-----------------|
| R 04 30 120 | | 120/210 | 30/25 |



COMPLETO DI-COMLETE WITH



Art. R0628000 (pag. 527)

Art. N4035000 (pag. 527)

Mezzo marinaio telescopico e pompa

Realizzato in tubo di alluminio anodizzato, con gancio in nylon e manopola terminale. Molto robusto, grazie al suo importante diametro, si può bloccare in qualsiasi posizione grazie al sistema di bloccaggio a camme.

Telescopic boat hook and bilge pump

Manufactured in anodized aluminium pipe, with nylon hook and handle. Very sturdy, thanks to its large diameter, it can be stopped in any position by means of a special cam locking system.

| Articolo - Item | €/pc. | Lunghezza-Length min/max cm. | Tubo-Pole Ø mm. |
|-----------------|-------|------------------------------|-----------------|
| R 05 35 200 | | 110/200 | 30/35 |



COMPLETO DI-COMLETE WITH



Art. R0628000 (pag. 527)

Art. N4035000 (pag. 527)

Mezzo marinaio telescopico

Telescopic boat hook

Gancio in nylon grigio, manico in alluminio anodizzato e doppia manopola di impugnatura.

Grey nylon hook, anodized aluminium pole and double handle.

| Articolo - Item | €/pc. | Lunghezza-Length min/max cm. | Tubi-Poles Ø mm. |
|-----------------|-------|------------------------------|------------------|
| R 04 30 210 | | 120/210 | 25/30 |
| R 04 30 061 | | 60/100 | 25/30 |



COMPLETE WITH

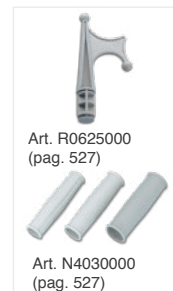

Mezzo marinaio telescopico «Multicolor»

Telescopic boat hook «Multicolor»

Gancio in nylon grigio, manico in alluminio verniciato con resine epossidiche e doppia impugnatura.

Grey nylon hook, epoxy resin coated aluminium handle with double knob grip.

| Articolo - Item | €/pc. | Colore-Colour | Lunghezza-Length min/max cm. | Tubi-Poles Ø mm. |
|-----------------|-------|---|------------------------------|------------------|
| R 00 74 121 | | <input type="checkbox"/> Bianco-White | 120/210 | 25/30 |
| R 00 75 121 | | <input checked="" type="checkbox"/> Blu-Blue | 120/210 | 25/30 |
| R 00 82 121 | | <input checked="" type="checkbox"/> Rosso-Red | 120/210 | 25/30 |

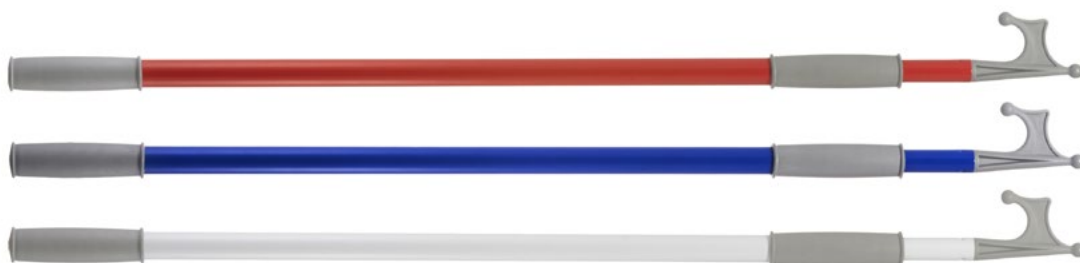

COMPLETE WITH



Mezzo marinaio telescopico «Lux»

Telescopic boat hook «Lux»

Gancio in nylon grigio, manico in alluminio anodizzato e doppia manopola ergonomica in gomma.

Grey nylon hook, anodized aluminium pole and double ergonomic rubber handle.

| Articolo - Item | €/pc. | Lunghezza-Length min/max cm. | Tubi-Poles Ø mm. |
|-----------------|-------|------------------------------|------------------|
| R 00 30 120 | | 120/210 | 25/30 |
| R 00 30 060 | | 60/100 | 25/30 |



COMPLETE WITH

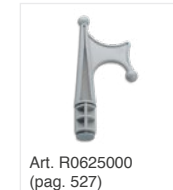

Mezzo marinaio telescopico «Lux Multicolor»

Telescopic boat hook «Lux Multicolor»

Gancio in nylon grigio, manico in alluminio anodizzato e doppia manopola ergonomica in gomma.

Grey nylon hook, anodized aluminium pole and double ergonomic rubber handle.

| Articolo - Item | €/pc. | Colore-Colour | Lunghezza-Length min/max cm. | Tubi-Poles Ø mm. |
|-----------------|-------|---|------------------------------|------------------|
| R 00 74 120 | | <input type="checkbox"/> Bianco-White | 120/210 | 25/30 |
| R 00 82 120 | | <input checked="" type="checkbox"/> Rosso-Red | 120/210 | 25/30 |
| R 00 75 120 | | <input checked="" type="checkbox"/> Blu-Blue | 120/210 | 25/30 |

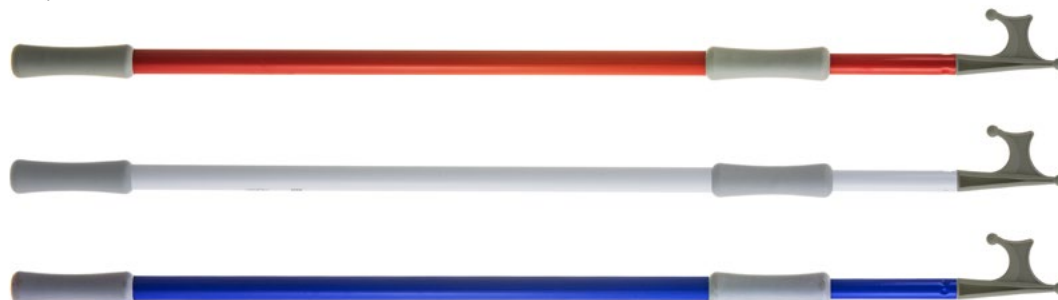

COMPLETE WITH

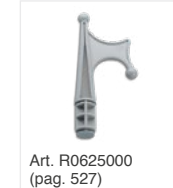

Kit Sistema Recupero boe-gavitelli «Jolly Hook»

Oltre a funzionare come gancio d'accosto, permette con un solo movimento di agganciare l'occhio del gavitello e recuperare a doppiino la cima d'ormeggio.

Provvisto di:

- Gancio mezzo marinaio in nylon
- Gancio «Jolly Hook» in tecnopolimero
- Manico in lega leggera lunghezza 120-215 mm.

Mooring boat hook kit «Jolly Hook»

In addition to functioning as a mooring hook, it allows the eye of the buoy to be hooked with a single movement.

Kit complete with:

- Nylon hook
- Hook «Jolly Hook» in polymer
- Light alloy handle 120-215 mm

| Articolo - Item | €/pc. | Lunghezza-Length cm. | Ø mm. | kg. |
|-----------------|-------|----------------------|-------|-------|
| R 38 30 120 | | 120-215 | 25-22 | 4,000 |



R3804150
Pag.385

R3804135

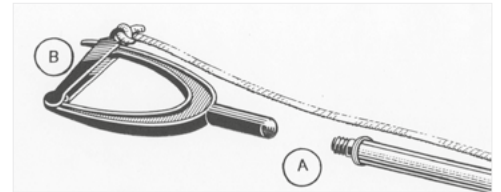
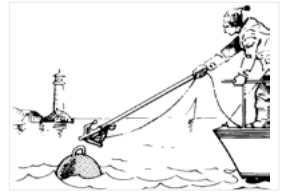

Gancio «Jolly Hook» applicabile su tutti i mezzi marinai

Gancio speciale a doppia apertura che permette di agganciare a distanza l'occhio di una boa o di un ormeggio e di riportare la cima in coperta. Fabbricato in nylon ad alta resistenza di colore nero.

«Jolly Hook» suitable for fitting on all boat hooks

Special double opening hook allowing to hook up the eye of a buoy when mooring and to recover the rope on the deck. Manufactured in very strong black nylon.

| Articolo - Item | €/pc. | kg. |
|-----------------|-------|-------|
| R 09 00 060 | | 0,120 |

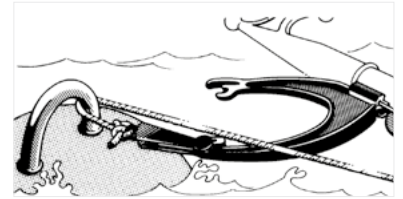
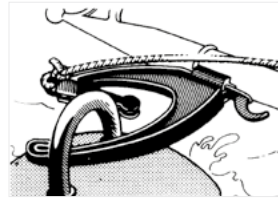
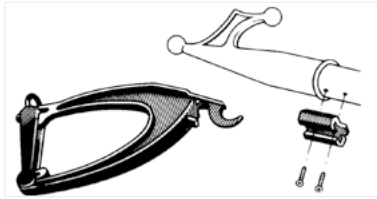
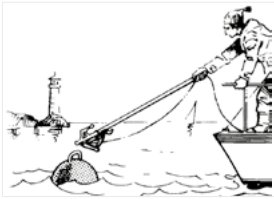

RAFFI | ALUMINIUM GAFFS

Raffio con gancio da 10 cm.

Fabbricato in alluminio anodizzato. Raffio inox Ø 8 mm. Tubo Ø 25 mm.

Aluminium gaff with hook 10 cm.

Manufactured in anodised aluminium. Stainless steel gaff Ø 8 mm. Pipe Ø 25 mm.

| Articolo - Item | €/pc. | Gancio-Hook Ø mm. | Gancio-Hook L cm. | Lunghezza totale-Full length cm. | Tubo-Pipe Ø mm. |
|-----------------|-------|-------------------|-------------------|----------------------------------|-----------------|
| R 08 10 055 | | 8 | 10 | 55 | 25 |
| R 08 10 140 | | 8 | 10 | 140 | 25 |



Raffio telescopico con gancio da 10 cm.

Fabbricato in alluminio anodizzato. Raffio inox Ø 8 mm. Tubo Ø 25 mm.

Aluminium telescopic gaff with hook 10 cm.

Manufactured in anodised aluminium. Stainless steel gaff Ø 8 mm. Pipe Ø 25 mm.

| Articolo - Item | €/pc. | Gancio-Hook Ø mm. | Gancio-Hook L cm. | Lunghezza totale-Full length cm. | Tubo-Pipe Ø mm. |
|-----------------|-------|-------------------|-------------------|----------------------------------|-----------------|
| R 08 10 120 | | 8 | 10 | 80-120 | 25 |



Gancio di ricambio Spare hook

Fabbricato in nylon grigio. Manufactured in grey nylon.

| Articolo - Item | €/pc. | Foro-Hole Ø mm. |
|-----------------|-------|-----------------|
| R 06 25 000 | | 25 |



Gancio di ricambio Spare hook

Fabbricato in nylon grigio. Manufactured in grey nylon.

| Articolo - Item | €/pc. | Foro-Hole Ø mm. |
|-----------------|-------|-----------------|
| R 06 28 000 | | 30 |



Gancio di ricambio Spare hook

Fabbricato in ottone lucido. Manufactured in polished brass.

| Articolo - Item | €/pc. | Foro-Hole Ø mm. |
|-----------------|-------|-----------------|
| R 08 28 180 | | 28 |
| R 08 32 210 | | 32 |



Pala di ricambio Spare blade

Fabbricata in ABS nero. Manufactured in black ABS.

| Articolo - Item | €/pc. | Foro-Hole Ø mm. |
|-----------------|-------|-----------------|
| R 16 35 080 | | 35 |



Pala di ricambio Spare blade

Fabbricata in ABS bianco. Manufactured in white ABS.

| Articolo - Item | €/pc. | Foro-Hole Ø mm. |
|-----------------|-------|-----------------|
| R 25 25 080 | | 25 |



Pala di ricambio Spare blade

Fabbricata in ABS bianco. Manufactured in white ABS.

| Articolo - Item | €/pc. | Foro-Hole Ø mm. |
|-----------------|-------|-----------------|
| R 22 25 030 | | 25 |



Impugnature per remi e mezzi marinai Handles for boat hooks & oars

Fabbricate in gomma. Manufactured in rubber.

| Articolo - Item | €/pc. | Per tubo-For pipe Ø mm. |
|-----------------|-------|-------------------------|
| N 40 25 000 | | 25 |
| N 40 30 000 | | 30 |
| N 40 35 000 | | 35 |



N4025000 N4030000 N4035000

Collare universale Spare collar

Fabbricato in plastica. Manufactured in plastic.

| Articolo - Item | €/pc. | Ø interno-inner mm. |
|-----------------|-------|---------------------|
| R 29 34 000 | | 34/38 |



Collari di ricambio per remi Spare collars for oars

Fabbricati in plastica. Manufactured in plastic.

| Articolo - Item | €/pc. | Ø interno inner mm. | Ø esterno outer mm. | Lunghezza Length mm. |
|-----------------|-------|---------------------|---------------------|----------------------|
| R 29 36 000 | | 36 | 43 | 84 |
| R 29 40 000 | | 40 | 46 | 84 |
| R 29 46 000 | | 46 | 54 | 84 |
| R 29 54 000 | | 46 | 54 | 160 |



Scalmi

Fabbricati in Delrin.

| Articolo - Item | €/pc. | Gambo-Shaft Ø mm. | Rowlocks | | | |
|-----------------|-------|----------------------|-----------------------|----------|----------|----------|
| | | | Materiale Material | A mm. | B mm. | C mm. |
| R 30 45 000 | | 18 | Ivory Delrin | 41 | 51 | 45 |
| R 30 50 000 | | 18 | Ivory Delrin | 45 | 58 | 45 |
| R 30 50 001 | | 18 | Black Delrin | 45 | 58 | 45 |



Scalmi

Fabbricati in ottone.

| Articolo - Item | €/pc. | Gambo-Shaft Ø mm. | Rowlocks | | | |
|-----------------|-------|----------------------|-----------------------|----------|----------|----------|
| | | | Materiale Material | A mm. | B mm. | C mm. |
| R 34 45 140 | | 12 | Ottone-Brass | 38 | 48 | 68 |
| R 34 58 320 | | 14 | Ottone-Brass | 41 | 58 | 72 |

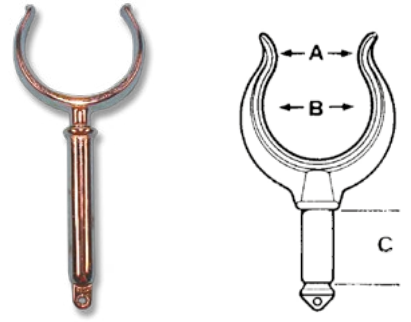

Scalmo

Fabbricato in ottone.

| Articolo - Item | €/pc. | Gambo-Shaft Ø mm. | Rowlock | | | |
|-----------------|-------|----------------------|-----------------------|----------|----------|----------|
| | | | Materiale Material | A mm. | B mm. | C mm. |
| R 34 14 001 | | 12 | Ottone-Brass | 40 | 50 | 40 |

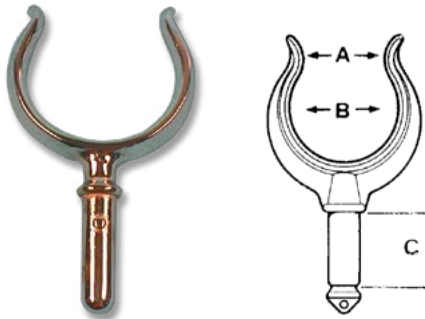

Portascalmo

Fabbricati in Delrin. Montaggio orizzontale.

| Articolo - Item | €/pc. | Foro-Hole Ø mm. | ↑ mm. | Rowlock sockets |
|-----------------|-------|--------------------|-------|-----------------------|
| | | | | Materiale Material |
| R 31 50 012 | | 18 | 55x40 | Ivory Delrin |
| R 31 50 014 | | 18 | 55x40 | Black Delrin |



Portascalmo

Fabbricati in Delrin. Montaggio a parete.

| Articolo - Item | €/pc. | Foro-Hole Ø mm. | ↑ mm. | Rowlock sockets |
|-----------------|-------|--------------------|-------|-----------------------|
| | | | | Materiale Material |
| R 31 50 025 | | 18 | 60x40 | Ivory Delrin |
| R 31 80 025 | | 18 | 60x40 | Black Delrin |

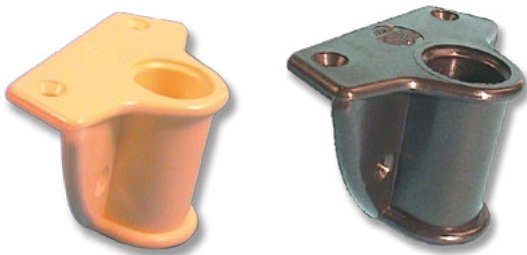

Portascalmo

Montaggio orizzontale. Foro cieco.

| Articolo - Item | €/pc. | Foro-Hole Ø mm. | ↑ mm. | Rowlock socket |
|-----------------|-------|--------------------|-------|-----------------------|
| | | | | Materiale Material |
| R 34 14 002 | | 12 | 80x31 | Ottone-Brass |



Portascalmo

Montaggio orizzontale.

| Articolo - Item | €/pc. | Foro-Hole Ø mm. | ↑ mm. | Rowlock sockets |
|-----------------|-------|--------------------|-------|-----------------------|
| | | | | Materiale Material |
| R 33 10 043 | | 12 | 60x23 | Ottone-Brass |
| R 33 10 076 | | 14 | 60x35 | Ottone-Brass |



Portascalmo

Montaggio verticale.

| Articolo - Item | €/pc. | Foro-Hole Ø mm. | ↑ mm. | Rowlock socket |
|-----------------|-------|--------------------|-------|-----------------------|
| | | | | Materiale Material |
| R 39 12 035 | | 12 | 50x35 | Ottone-Brass |



Clips fermaoggetti in nylon

Nylon clips

Fissaggio con 2 viti.

Fastening by means of 2 screws.

| Articolo - Item | €/pc. | €/Box | Articolo - Item | €/pc. | €/Box | Ø mm. | kg. |
|-----------------|-------|-------|-----------------|-------|-------|-------|-------|
| N 09 22 074 | | | N 09 22 028 | | | 22/28 | 0,014 |
| - | | | N 09 27 035 | | | 27/35 | 0,020 |
| N 09 34 074 | | | N 09 34 045 | | | 34/45 | 0,030 |



Clips in plastica fermaremi/ fermamanici tipo pesante

Plastic adjustable holders

Fabbricate in materiale plastico di colore nero. Adatte per mezzi marinai, remi, scalette e pompe di sentina.

Manufactured in first quality nylon. Suitable for boat hooks, oars, ladders, bilge pumps.

| Articolo - Item | €/pc. | €/Box | Adatte per-For Ø mm. | kg. |
|-----------------|-------|-------|----------------------|-------|
| N 09 38 011 | | | 38-45 | 0,011 |



Clips fermaremi «Confezione self-service»

Adjustable holders «Self-service»

Fabbricate in nylon nero di prima qualità. Adatte per mezzi marinai, remi, scalette, pompe di sentina. Complete di viti per il fissaggio.

Manufactured in first quality nylon. Suitable for boat hooks, oars, ladders, bilge pumps. With fixing screws.

| Articolo - Item | €/Paio-Pair | €/Box 12 Paia-Pairs | Adatte per-For Ø mm. |
|-----------------|-------------|---------------------|----------------------|
| N 09 25 000 | | | 25-40 |
| N 09 45 000 | | | 40-60 |



PAIA PAIRS

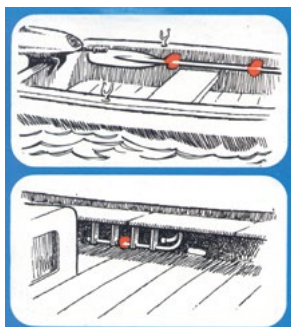

Clips fermaremi

Adjustable holders

Fabbricate in nylon nero di prima qualità. Adatte per mezzi marinai, remi, scalette, pompe di sentina.

Manufactured in first quality nylon. Suitable for boat hooks, oars, ladders, bilge pumps.

| Articolo - Item | €/pc. | €/Box | Adatte per-For Ø mm. | kg. |
|-----------------|-------|-------|----------------------|-------|
| N 09 25 015 | | | 25-40 | 0,100 |
| N 09 45 015 | | | 40-60 | 0,140 |

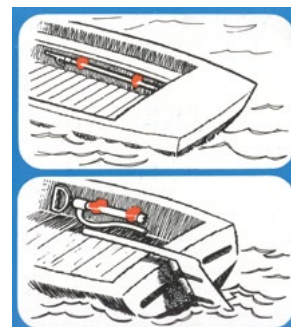

Scalmo in plastica

Plastic rowlock

Con perno a scatto in ottone per remi Ø 35 mm.

With snap-in brass pin for oars Ø 35 mm.

| Articolo - Item | €/pc. | Ø mm. | Lunghezza-Length mm. |
|-----------------|-------|-------|----------------------|
| R 32 35 000 | | 12 | 35 |



PASSERELLE | GANGWAYS

COMPLETO DI-COMLETE WITH

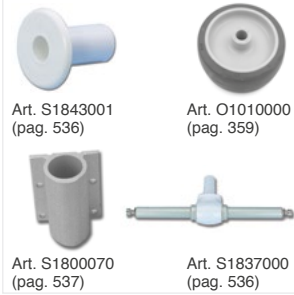

SUGGESTED ITEM



Passerella pieghevole in carabottino

Fabbricata totalmente in alluminio estruso e pianale in teak africano. Provvista di ruote e di perno piroettante.

Folding gangway with wooding grating

Fully manufactured in aluminium and grating in African teak. With wheels and pivot pin.

| Articolo - Item | €/pc. | A1 cm. | A2 cm. | B cm. | C cm. | D cm. | Portata Max load kg. | kg. |
|-----------------|-------|--------|--------|-------|-------|-------|----------------------|-------|
| S 61 53 200 | | 200 | 100 | 36 | 7,5 | 15 | 140 | 10,00 |
| S 61 53 230 | | 230 | 115 | 36 | 7,5 | 15 | 140 | 15,00 |
| S 61 53 260 | | 260 | 130 | 36 | 7,5 | 15 | 130 | 18,00 |

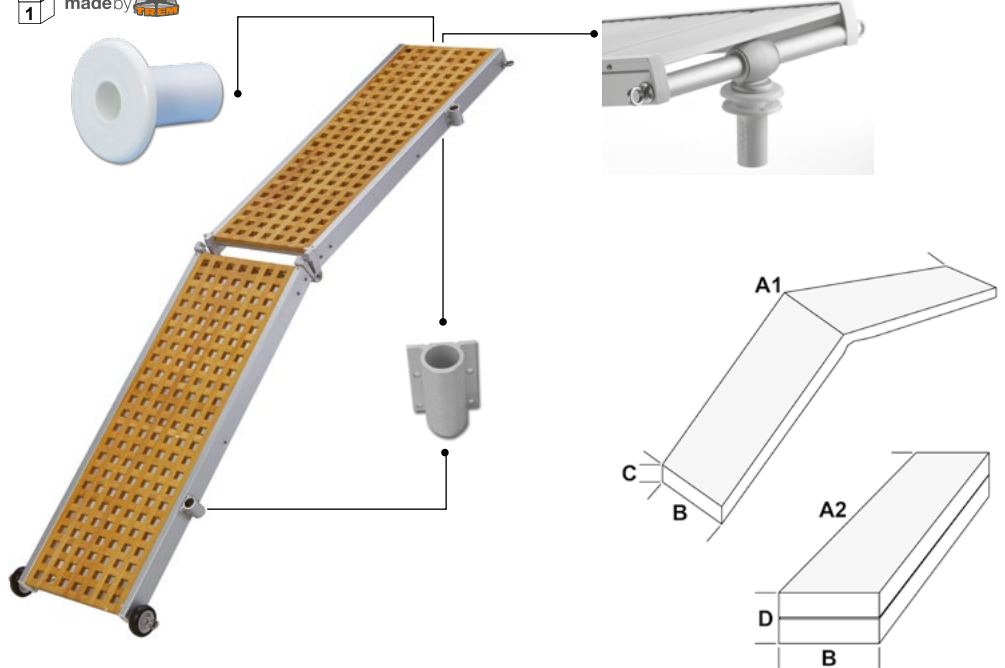

COMPLETO DI-COMLETE WITH

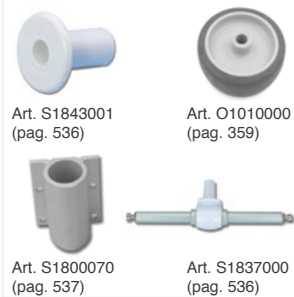

SUGGESTED ITEM



Passerella in carabottino

Fabbricata totalmente in alluminio estruso e pianale in teak africano. Provvista di ruote e di perno piroettante.

Gangway with wooding grating

Fully manufactured in aluminium and grating in African teak. With wheels and pivot pin.

| Articolo - Item | €/pc. | A cm. | B cm. | C cm. | Portata Max load kg. | kg. |
|-----------------|-------|-------|-------|-------|----------------------|------|
| S 61 53 201 | | 190 | 36 | 7,5 | 140 | 9,00 |

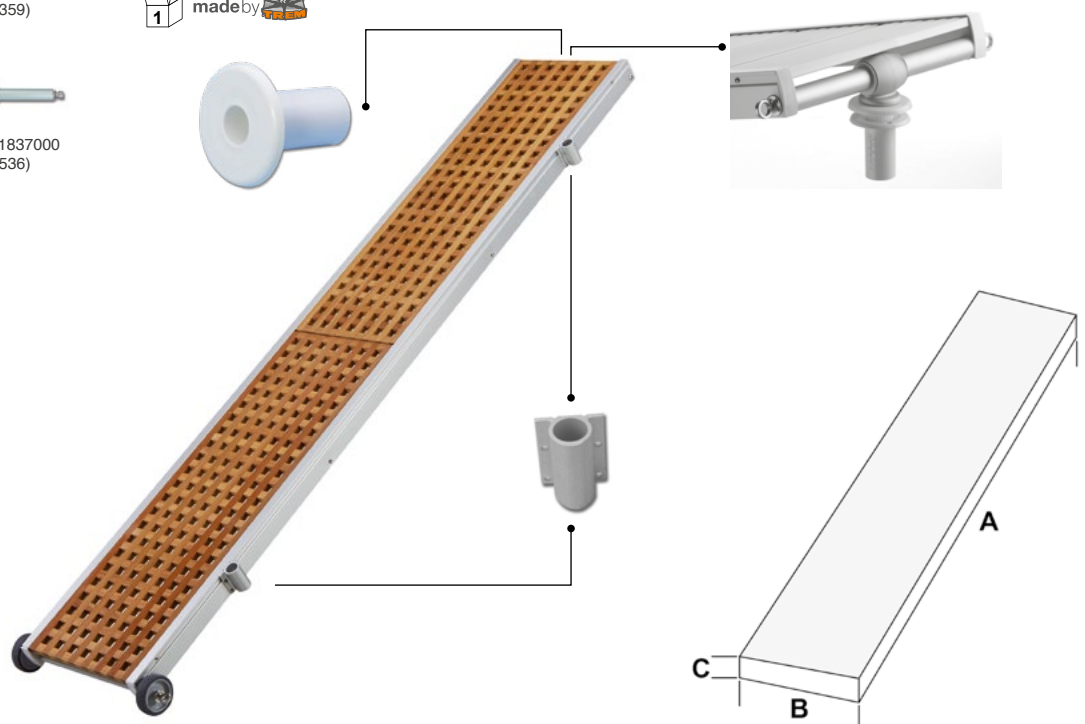

Passerella pieghevole in alluminio

Fabbricata totalmente in alluminio estruso.
Provvista di ruote e di perno piroettante.

| Articolo - Item | €/pc. | Lunghezza Madrella | A1 cm. | A2 cm. | B cm. | C cm. | D cm. | Portata Max load kg. | kg. |
|-----------------|-------|--------------------|--------|--------|-------|-------|-------|----------------------|-------|
| S 62 31 200 | | Standard (10 cm.) | 200 | 100 | 36 | 7,5 | 15 | 140 | 9,00 |
| S 63 31 230 | | Doppia (15 cm.) | 230 | 115 | 36 | 7,5 | 15 | 140 | 11,00 |
| S 63 31 260 | | Doppia (15 cm.) | 260 | 130 | 36 | 7,5 | 15 | 130 | 12,00 |

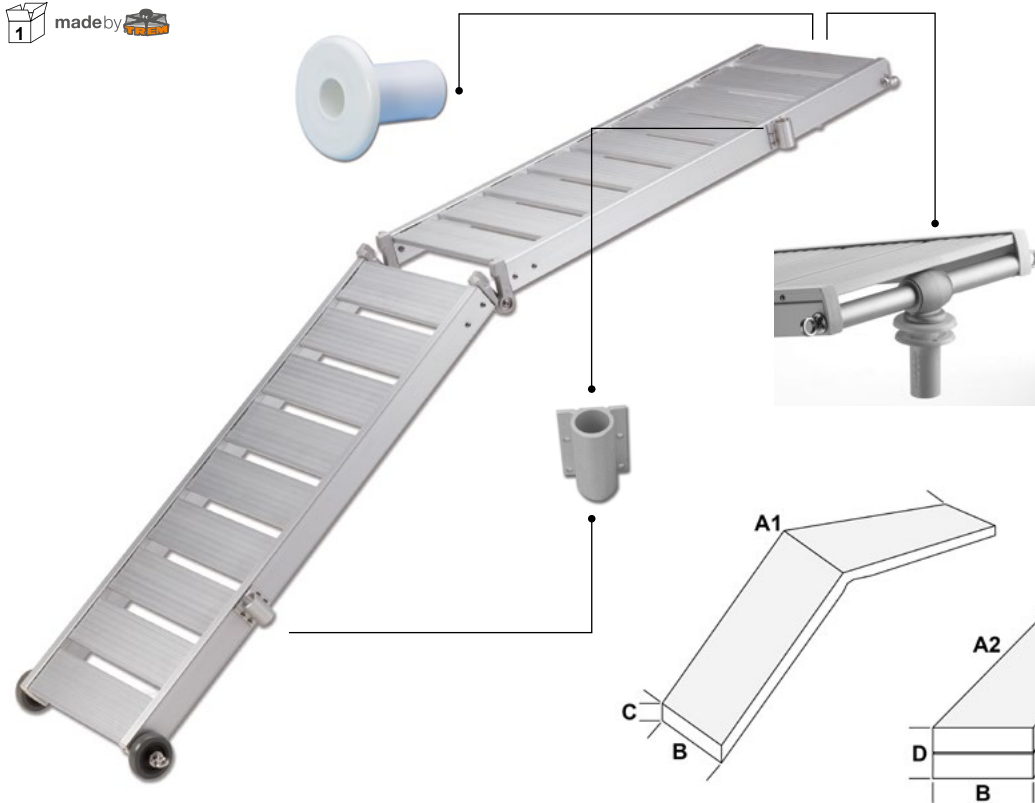

Super light gangway with alu anti-slip ground

Fully manufactured in aluminium.
With wheels and pivot pin.

COMPLETO DI-COMLETE WITH



SUGGESTED ITEM



Passerella in alluminio

Fabbricata totalmente in alluminio estruso.
Provvista di ruote e di perno piroettante.

| Articolo - Item | €/pc. | Lunghezza Madrella | A cm. | B cm. | C cm. | Portata Max load kg. | kg. |
|-----------------|-------|--------------------|-------|-------|-------|----------------------|-------|
| S 62 31 201 | | Standard (10 cm.) | 190 | 36 | 7,5 | 150 | 9,00 |
| S 63 31 231 | | Doppia (15 cm.) | 230 | 36 | 7,5 | 150 | 11,00 |

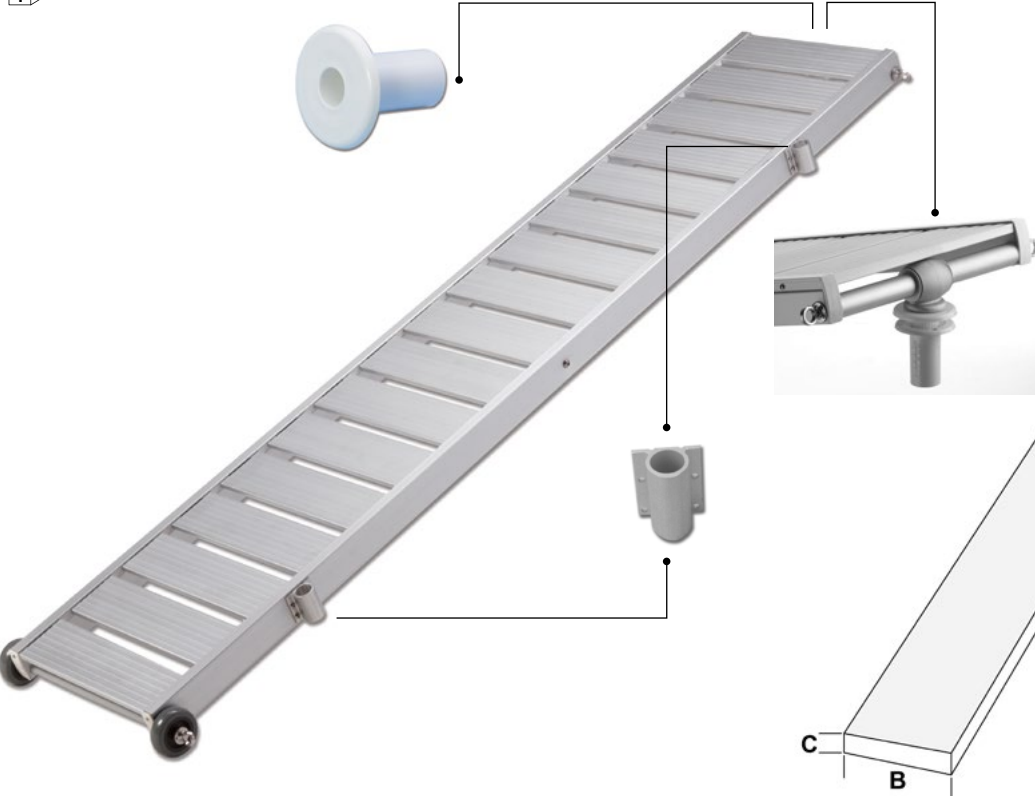

Super light gangway with alu anti-slip ground

Fully manufactured in aluminium.
With wheels and pivot pin.

COMPLETO DI-COMLETE WITH

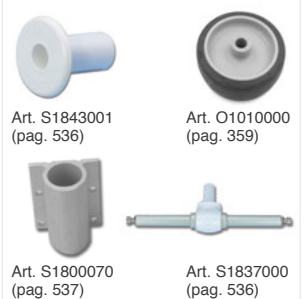

SUGGESTED ITEM

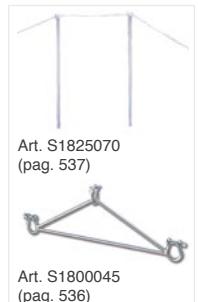

PASSERELLE | GANGWAYS

COMPLETE WITH

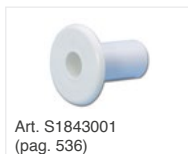

Passerella pieghevole in carabottino

Fabbricata totalmente in legno.
Provvista di ruote e di perno Ø 25 mm.

| Articolo - Item | €/pc. | A1 cm. | A2 cm. | B cm. | C cm. | D cm. | Portata Max load kg. | kg. |
|-----------------|-------|--------|--------|-------|-------|-------|----------------------|------|
| S 21 53 200 | | 200 | 100 | 33 | 7 | 14 | 140 | 8,00 |



Super light folding gangway in marine wood

Fully manufactured in wood.
With wheels and pivot Ø 25 mm.

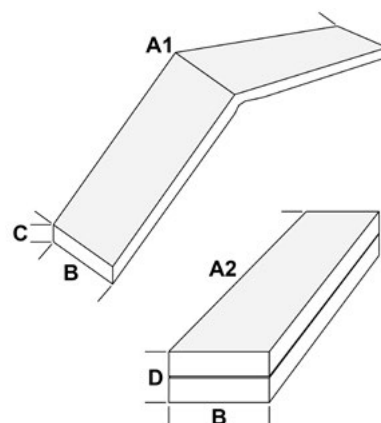

SUGGESTED ITEM



COMPLETE WITH



Passerella pieghevole in legno

Fabbricata totalmente in legno.
Provvista di ruote e di perno piroettante.

| Articolo - Item | €/pc. | A1 cm. | A2 cm. | B cm. | C cm. | D cm. | Portata Max load kg. | kg. |
|-----------------|-------|--------|--------|-------|-------|-------|----------------------|-------|
| S 21 51 201 | | 200 | 100 | 33 | 7 | 14 | 140 | 10,00 |



Super light folding gangway in marine wood

Fully manufactured in wood.
With wheels and turning pivot.

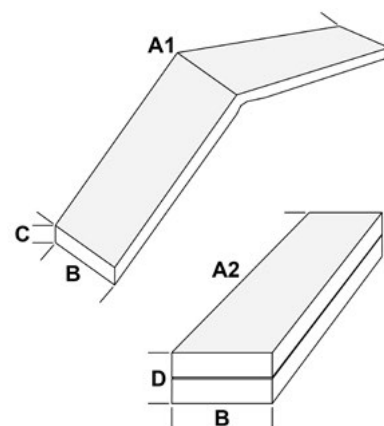

SUGGESTED ITEM



COMPLETE WITH



Passerella in legno

Fabbricata totalmente in legno.
Provvista di ruote e di perno.

| Articolo - Item | €/pc. | A1 cm. | B cm. | C cm. | Portata Max load kg. | kg. |
|-----------------|-------|--------|-------|-------|----------------------|------|
| S 21 51 200 | | 200 | 33 | 7 | 150 | 8,00 |

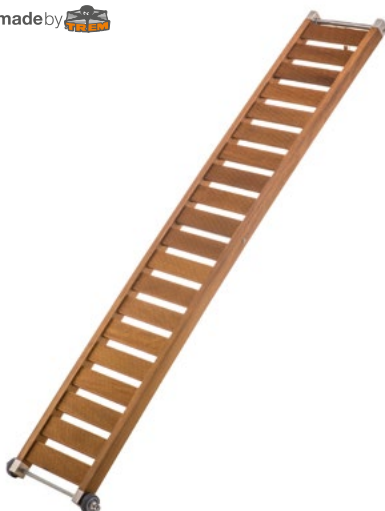

Super light gangway in marine wood

Fully manufactured in wood.
With wheels and pivot.

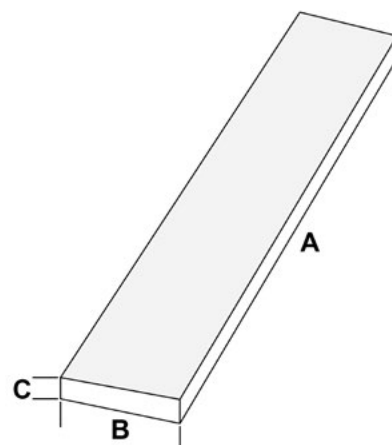

SUGGESTED ITEM



Passerella pieghevole in acciaio inox e carabottino

Completa di attacchi terminali, di ruote e perno ø 25 mm. piroettante con boccola. Fabbricata in tubo di acciaio inox Aisi 316. Pianale in carabottino di Iroko.

Folding gangway in stainless steel with wooden grating

Provided with wheels. Stainless steel pipe Aisi 316. With fastening accessories. Oval profile 20 x 40 mm.

| Articolo - Item | €/pc. | A1 cm. | A2 cm. | B cm. | C cm. | D cm. | Portata Max load kg. | kg. |
|-----------------|-------|--------|--------|-------|-------|-------|----------------------|-------|
| S 28 32 160 | | 190 | 95 | 33 | 6 | 12 | 130 | 12,00 |

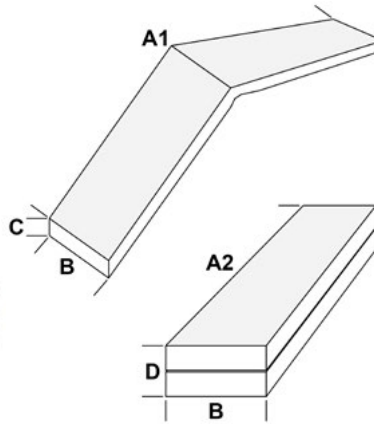

COMPLETO DI-COMLETE WITH



Art. S1843001 (pag. 536) Art. O1010000 (pag. 359)

SUGGESTED ITEM



Art. S1800045 (pag. 536)

Passerella pieghevole in carabottino

Pianale in legno carabottino.

Folding gangway with wooden grating

Antisliding wooden ground.

| Articolo - Item | €/pc. | A1 cm. | A2 cm. | B cm. | C cm. | D cm. | Portata Max load kg. | kg. |
|-----------------|-------|--------|--------|-------|-------|-------|----------------------|-------|
| S 21 00 230 | | 230 | 120 | 30 | 12 | 25 | 150 | 12,00 |

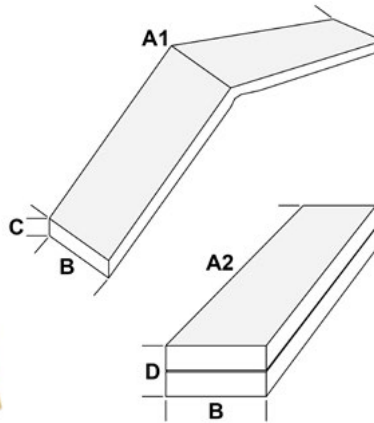

COMPLETO DI-COMLETE WITH



Art. S1843001 (pag. 536) Art. O1010000 (pag. 359)

SUGGESTED ITEM



Art. S1825070 (pag. 537)

Art. S1800045 (pag. 536)

Art. S1800050 (pag. 537)

Passerella pieghevole in legno antiscivolo

Pianale in legno antiscivolo.

Folding gangway with antisliding wood

Antisliding wooden ground.

| Articolo - Item | €/pc. | A1 cm. | A2 cm. | B cm. | C cm. | D cm. | Portata Max load kg. | kg. |
|-----------------|-------|--------|--------|-------|-------|-------|----------------------|-------|
| S 21 30 200 | | 200 | 100 | 30 | 12 | 25 | 150 | 10,50 |
| S 21 30 230 | | 230 | 120 | 30 | 12 | 25 | 150 | 11,00 |

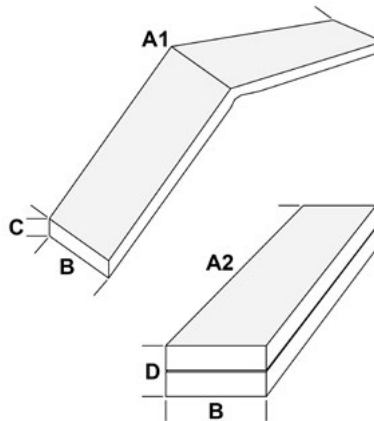

COMPLETO DI-COMLETE WITH



Art. S1843001 (pag. 536) Art. O1010000 (pag. 359)

SUGGESTED ITEM



Art. S1825070 (pag. 537)

Art. S1800045 (pag. 536)

Art. S1800050 (pag. 537)

COMPLETO DI-COMLETE WITH



Art. S1843001
(pag. 536)

Art. S2835830
(pag. 537)

SUGGESTED ITEM



Art. S1800045
(pag. 536)

Passerella tri-pieghevole Aisi 316

Completa di sacca.
Pianale in legno carabottino.

| Articolo - Item | €/pc. | A1 cm. | A2 cm. | B cm. | C cm. | D cm. | Portata Max load kg. | kg. |
|-----------------|-------|--------|--------|-------|-------|-------|----------------------|-------|
| S 28 32 200 | | 220 | 80 | 33 | 6 | 15 | 130 | 15,00 |



Folding gangway in Aisi 316

Complete with bag.
Antisliding wooden ground.

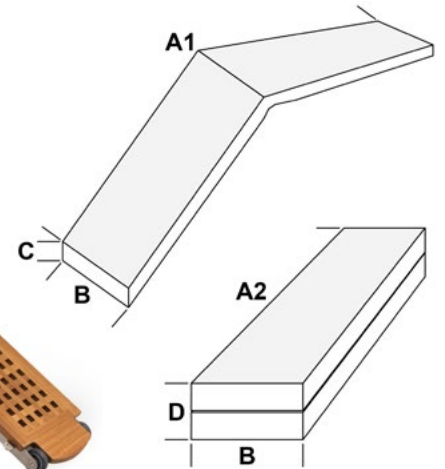

COMPLETO DI-COMLETE WITH



Art. S1843001
(pag. 536)

Art. S2835830
(pag. 537)

SUGGESTED ITEM



Art. S1800045
(pag. 536)

Passerella tri-pieghevole in alluminio

Fabbricata in alluminio verniciata bianca, con pianale in legno ricoperto da antiscivolo bianco. Completa di sacca.

| Articolo - Item | €/pc. | A1 cm. | A2 cm. | B cm. | C cm. | D cm. | Portata Max load kg. | kg. |
|-----------------|-------|--------|--------|-------|-------|-------|----------------------|-------|
| S 28 31 220 | | 220 | 80 | 30 | 6 | 15 | 120 | 12,00 |



Folding gangway with super light alu frame

Provided with wheels. Made of painted white aluminium. Wooden ground with white anti-slip covering. Complete with bag.

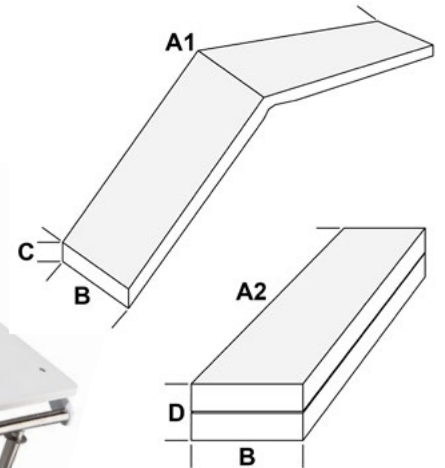

COMPLETO DI-COMLETE WITH

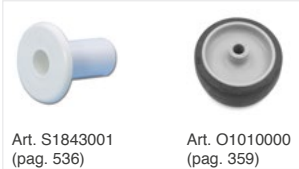

Art. S1843001
(pag. 536)

Art. O1010000
(pag. 359)

SUGGESTED ITEM



Art. S1800045
(pag. 536)

Passerella in alluminio

Realizzata con profili di alluminio e pianale in legno antiscivolo. Priva di candelieri.

| Articolo - Item | €/pc. | A cm. | B cm. | C cm. | Portata Max load kg. | kg. |
|-----------------|-------|-------|-------|-------|----------------------|------|
| S 49 00 200 | | 200 | 30 | 6 | 150 | 8,00 |



Aluminium gangway

Aluminium profile and antisliding wooden ground. Stanchions not included.

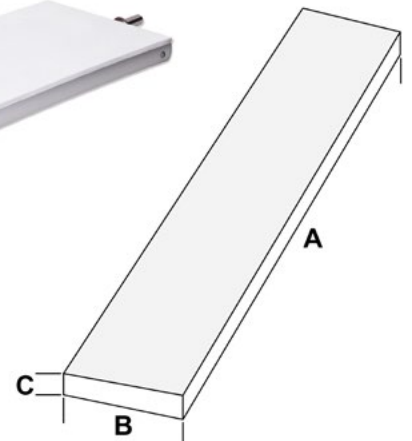

Passerella telescopica elettrica 12V con pianale in carabottino

Passerella con movimentazione elettrica. Pianale in legno carabottino. Struttura monotrave in alluminio anodizzato smaltato bianco. Assorbimento max 2,5A. Movimento automatico a motore elettrico con telecomando e centralina. Candelieri abbattibili automaticamente. Pianale in legno antiscivolo e struttura in alluminio. Staffa per montaggio all'imbarcazione. Completa di pannello di comando a distanza, telecomando a breve distanza e di radiocomando a lunga distanza. **Modello telescopico servoassistito.**

Telescopic electric gangway 12V with wooden grating floor

Electric gangway. Anti-sliding wooden grating floor. Single beam framework in white enameled anodised aluminium. Consumption max. 2,5A. Servo-assisted model complete with remote radio control and electric station. Complete with pistons. 12/24 V. power supply. Dinghy max. 50 kg. Stanchions can be brought down automatically. With built-in control panel, short distance remote control and long distance remote control. **Servo-assisted telescopic model.**

COMPLETO DI-COMLETE WITH

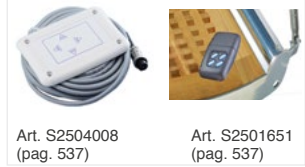

Art. S2504008 (pag. 537)

Art. S2501651 (pag. 537)

| Articolo - Item | €/pc. | Lunghezza-Length cm. | | Larghezza-Width max cm. | Portata-Load | | Kg. sollevabili Lifting weight kg. | Volts | kg. |
|-----------------|-------|----------------------|---------------|-------------------------|--------------|-----|------------------------------------|-------|-----|
| | | Aperta-Open | Chiusa-Closed | | Aperta-Open | kg. | | | |
| S 23 50 200 | | 210 | 136 | 40 | 100 | 50 | 12 | 34,00 | |



WHITE STAR



Su richiesta sono disponibili anche le versioni a 24V. - On request are available also the 24V. models

Passerella telescopica elettrica 12V con pianale in legno

Passerella con movimentazione elettrica. Pianale in legno antiscivolo. Struttura monotrave in alluminio smaltato bianco. Assorbimento max 2,5A. Alimentazione a 12/24V. Fabbricata in alluminio anodizzato e smaltato bianco. Movimento automatico a motore elettrico con telecomando e centralina. Candelieri abbattibili automaticamente. Pianale in legno antiscivolo e struttura in alluminio. Staffa per montaggio all'imbarcazione. Completa di pannello di comando ad incasso, telecomando a breve distanza e di radiocomando a lunga distanza. **Modello telescopico servoassistito**

Telescopic electric gangway 12V with wooden floor

Electric gangway. Anti-sliding wooden floor. Single beam framework in white enameled aluminium. Consumption max. 2,5A. Servo-assisted model complete with remote radio control and electric station. Frame in white enameled anodised aluminium. Complete with pistons. 12/24 V. power supply. Stanchions can be brought down automatically. With built-in control panel, short distance remote control and long distance remote control. **Servo-assisted telescopic model.**

COMPLETO DI-COMLETE WITH



Art. S2504008 (pag. 537)

Art. S2501651 (pag. 537)

| Articolo - Item | €/pc. | Lunghezza-Length cm. | | Larghezza-Width max cm. | Portata-Load | | Kg. sollevabili Lifting weight kg. | Volts | kg. |
|-----------------|-------|----------------------|---------------|-------------------------|--------------|-----|------------------------------------|-------|-----|
| | | Aperta-Open | Chiusa-Closed | | Aperta-Open | kg. | | | |
| S 23 60 200 | | 210 | 136 | 40 | 100 | 50 | 12 | 34,00 | |



WHITE STAR



Su richiesta sono disponibili anche le versioni a 24V. - On request are available also the 24V. models

ACCESSORI PASSERELLE | GANGWAYS ACCESSORIES

Bilancino

Fabbricato in acciaio inox lucidato. Per sostegno passerella. Provvisto di 3 grilli ai 3 angoli per il collegamento allo strallo di poppa o ad una drizza e ai 2 cavi di sostegno della passerella.

| Articolo - Item | €/pc. | Larghezza-Width mm. |
|-----------------|-------|---------------------|
| S 18 00 045 | | 500 |

**Balance gear**

Manufactured in polished stainless steel, suitable for supporting gangways. Complete with 3 shackles on the 3 corners for fitting into the stern stay or into the halyard and into 2 gangway support wires.

Boccola ricambio passerella

Fabbricata in alluminio pressofuso. Coperchio in nylon.

Spare bushing for gangway

Manufactured in die-cast aluminum. Nylon cover.

| Articolo - Item | €/pc. | Flangia-Flange Ø mm. | Foro-Hole Ø mm. |
|-----------------|-------|----------------------|-----------------|
| S 18 43 001 | | 80 | 25 |

**Attacco piroettante per passerella**

Fabbricato in alluminio con perno pressofuso.

Turning fastening for gangway

Manufactured in aluminium with die-cast pivot.

| Articolo - Item | €/pc. | Lunghezza-Length mm. |
|-----------------|-------|----------------------|
| S 18 37 000 | | 330 |

**Supporto passerella per poppe negative/positive**

Fabbricato in Aisi 316.

Turning pivot support for stern positive-negative

Manufactured in Aisi 316.

| Articolo - Item | €/pc. | mm. |
|-----------------|-------|---------|
| S 28 85 120 | | 100x100 |

**Supporto passerella per poppa verticale 90°**

Fabbricato in Aisi 316.

Turning pivot support for stern vertical 90°

Manufactured in Aisi 316.

| Articolo - Item | €/pc. | mm. |
|-----------------|-------|---------|
| S 28 90 120 | | 100x100 |

**Supporto passerella al pulpito**

Fabbricato in Aisi 316.

Turning pivot support for pushpit

Manufactured in Aisi 316.

| Articolo - Item | €/pc. | Tubo-Pipe Ø mm. |
|-----------------|-------|-----------------|
| S 28 25 090 | | 22-25 |



Corrimano completo

Kit completo, provvisto di treccia e di due candelieri Ø 25 mm.

Hand-rail for gangway

Hand-rail manufactured in rope with base Ø 25 mm.

| Articolo - Item | €/Kit | Candelieri-Stanchions |
|-----------------|-------|-----------------------|
| S 18 25 070 | | Anodizzati-Anodised |



Candeliere

Completo di terminale passacorda in nylon.

Stanchion

Complete with nylon grommet terminal.

| Articolo - Item | €/pc. | Mod. | Ø mm. | H mm. |
|-----------------|-------|---------------------|-------|-------|
| S 18 25 071 | | Anodizzato-Anodised | 25 | 700 |



Attacchi candelieri passerelle monotrave

Kit composto da due attacchi a L da applicare sotto il pianale e da un occhiello da applicare sul lato bicchiere.

Stanchion joints for single-beam gangways

Kit made of a pair of L-type joints to be fitted under the top and an eye to be fitted on the fastening buckle.

| Articolo - Item | €/Kit | Kit composto da-Kit with |
|-----------------|-------|-------------------------------------|
| S 18 00 050 | | 2 attacchi + anello-2 joints + ring |



Attacco candeliere

Fabbricato in alluminio anodizzato.

Stanchion for hand rail

Manufactured in anodised alu.

| Articolo - Item | €/pc. | Foro-Hole Ø mm. | H mm. |
|-----------------|-------|-----------------|-------|
| S 18 00 070 | | 25 | 55 |



Sacca per passerella

Provvista di maniglie per il trasporto e di cerniera ermetica.

Bag for gangway

Supplied with carrying handles and hermetic hinge.

| Articolo - Item | €/pc. | mm. |
|-----------------|-------|---------------|
| S 18 80 150 | | 1200x200x400H |
| S 28 35 830 | | 1000x200x400H |



Comandi passerelle elettriche

Controls for electric gangways

| Articolo - Item | €/pc. | Mod. | mm. |
|-----------------|-------|---|-------|
| S 25 04 008 | | Comando remoto a parete Wall mounting remote control | 50x80 |
| S 25 01 651 | | Telecomando-Remote control | - |



S2504008



S2501651



Scalette da plancetta a scomparsa totale con slitta telescopica

Fabbricate totalmente in acciaio inox lucidato a specchio. Gradini ovali con pedana in plastica bianca. Versione con fermo frontale sciolto della parte sfilabile.

Retractable telescopic ladders

Fully manufactured in mirror polished stainless steel. Oval steps with white plastic coating. Equipped with fall safe front lock.

| Articolo - Item | €/pc. | Mod. | Gradini Steps | Tubi-Tubes Ø mm. | Lunghezza-Length mm. | | Larghezza max Max width mm. |
|-----------------|-------|--|---------------|------------------|----------------------|---------------|-----------------------------|
| | | | | | Aperta-Open | Chiusa-Closed | |
| S 31 03 003 | | Standard | 3 | 19/25/32 | 880 | 373 | 300 |
| S 31 03 004 | | Standard | 4 | 19/25/32/38 | 1155 | 405 | 300 |
| S 31 03 245 | | Stretta (per gommoni) Narrow (for dinghy) | 3 | 19/25/32 | 880 | 373 | 205 |

1 AISI 316

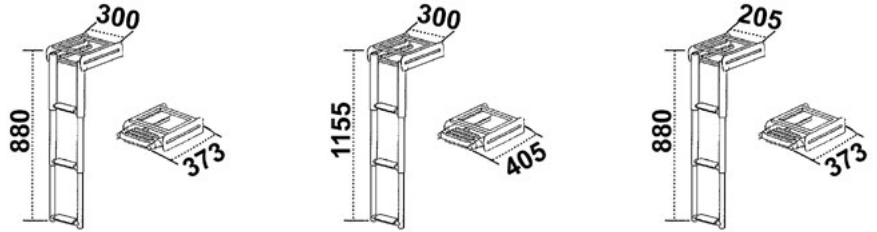

Scalette a scomparsa

Modello composto da una scaletta telescopica 3/4 gradini e box da incorporare nello spessore della plancetta. Fabbricate completamente in acciaio inox lucidato a specchio. Installazione facile e veloce sopra la linea di galleggiamento con cassonetto contenitivo con drenaggio. Box non a tenuta stagna.

Retractable telescopic ladders

Equipped with a telescopic ladder 3/4 steps and a box to be recessed into the bathing platform. Fully manufactured in mirror polished stainless steel. Easy and quick installation above waterline in a locker with drain. Non water tight box.

| Articolo - Item | €/pc. | Mod. | Gradini Steps | Lunghezza A Length A mm. | Frontalino Front plate mm. |
|-----------------|-------|--------------------|---------------|--------------------------|----------------------------|
| S 31 03 330 | | A scatto-Snap type | 3 | 870 | 390x86 |
| S 31 04 330 | | A scatto-Snap type | 4 | 1168 | 390x86 |

1 AISI 316

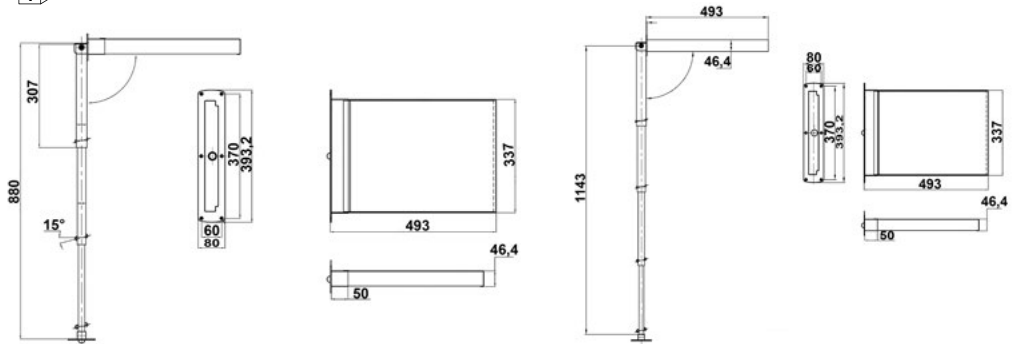

Scalette telescopiche da plancetta con maniglioni

Fabbricate in acciaio inox Aisi 316 lucidato a specchio. Gradini ovali con pedana in plastica bianca.

Retractable telescopic ladders with handles

Manufactured in mirror-polished Aisi 316 stainless steel with oval steps and white plastic footboard.

| Articolo - Item | €/pc. | Gradini Steps | Tubi-Tubes Ø mm. | Lunghezza-Length mm. | | Larghezza max Max width mm. |
|-----------------|-------|---------------|------------------|----------------------|---------------|-----------------------------|
| | | | | Aperta-Open | Chiusa-Closed | |
| S 19 11 800 | | 3 | 19/25/32 | 889 | 370 | 360 |
| S 19 11 804 | | 4 | 19/25/32/38 | 1156 | 394 | 375 |

1 AISI 316 **NEW** made by

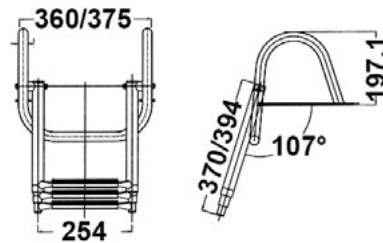

Cornice per uscita scalette a scomparsa in specchio di poppa

Realizzata in acciaio inox.

Aisi316 frame for stern ladders

Manufactured in stainless steel.

| Articolo - Item | €/pc. | mm. |
|-----------------|-------|------------|
| S 31 85 315 | | 315/280x85 |

made by

Scalette telescopiche da plancetta con maniglia di presa

Fabbricate in acciaio inox lucidato a specchio. Gradini ovali con pedana in plastica bianca.

Retractable telescopic ladders with handles

Manufactured in mirror-polished stainless steel with oval steps and white plastic footboard.

| Articolo - Item | €/pc. | Gradini Steps | Tubi-Tubes Ø mm. | Lunghezza-Length mm. | | Larghezza max Max width mm. |
|-----------------|-------|---------------|------------------|----------------------|---------------|-----------------------------|
| | | | | Aperta-Open | Chiusa-Closed | |
| S 31 03 300 | | 3 | 19/25/32 | 875 | 370 | 300 |
| S 31 04 315 | | 4 | 19/25/32/38 | 1145 | 395 | 315 |

 **1** **AISI 316** **NEW**

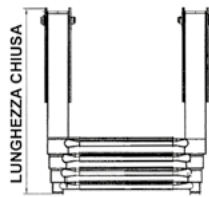
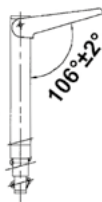

Scalette telescopiche da plancetta

Fabbricate in acciaio inox lucidato a specchio.

Retractable telescopic ladders

Manufactured in mirror-polished stainless steel.

| Articolo - Item | €/pc. | Articolo - Item | €/pc. | Mod. | Gradini Steps | Tubi-Tubes Ø mm. | Lunghezza-Length mm. | | Larghezza max Max width mm. |
|-----------------|-------|-----------------|-------|----------------|---------------|------------------|-----------------------------|--------------------------|-----------------------------|
| | | | | | | | Gradini bianchi-White steps | Gradini neri-Black steps | |
| S 31 01 003 | | S 31 80 003 | | Standard | 3 | 19/25/32 | 875 | 370 | 300 |
| S 31 01 004 | | S 31 80 004 | | Standard | 4 | 19/25/32/38 | 1145 | 394 | 315 |
| S 31 02 210 | | - | | Stretta-Narrow | 2 | 25/32 | 597 | 345 | 210 |
| S 31 01 245 | | - | | Stretta-Narrow | 3 | 19/25/32 | 875 | 368 | 210 |
| S 31 03 392 | | - | | Larga-Wide | 3 | 19/25/31 | 889 | 368 | 392 |

 **1** **AISI 316**



S3101003-004



S3102210-01245



S3103392



S3180003-004

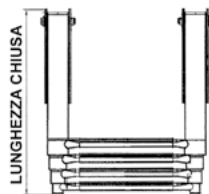
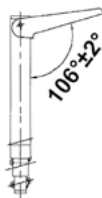

Scalette pieghevoli a 3 - 4 gradini con corrimano e gradini in legno per plancette di poppa

Fabbricate in tubo d'acciaio inox Aisi 316 con gradini in legno.
Tubo Ø 25 mm.

Boarding ladder with grabrail wooden steps

Manufactured in polished stainless steel pipe Aisi 316. Steps made in wood.
Pipe Ø 25 mm.

| Articolo - Item | €/pc. | Gradini Steps | A Larghezza totale A Full width mm. | Larghezza gradino Step width mm. | B Lunghezza totale B Full length mm. | Lunghezza totale chiusa su plancetta Full length closed mm. | kg. |
|-----------------|-------|---------------|-------------------------------------|----------------------------------|--------------------------------------|---|-------|
| S 19 22 003 | | 1+2=3 | 360 | 280 | 850 | 450 | 3,400 |
| S 19 22 004 | | 2+2=4 | 360 | 280 | 1000 | 670 | 3,900 |
| S 19 28 004 | | 1+3=4 | 360 | 280 | 1000 | 530 | 3,900 |

AISI 316 made by

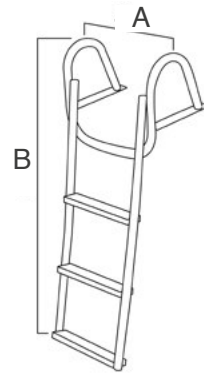
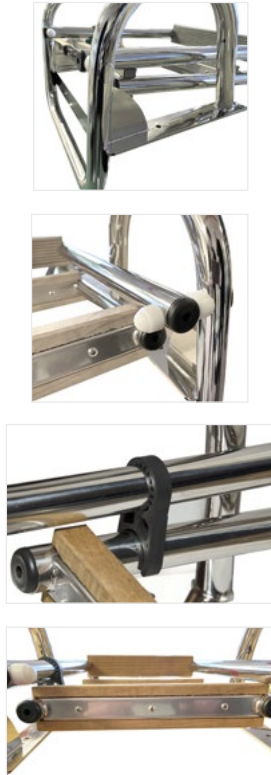

Scalette per pontili in alluminio

Tubo Ø 50 mm.

Dock ladders in aluminium

Pipe Ø 50 mm.

| Articolo - Item | €/pc. | Gradini Steps | kg. |
|-----------------|-------|---------------|-------|
| S 17 03 139 | | 3 | 6,000 |
| S 17 05 199 | | 5 | 8,000 |

made by

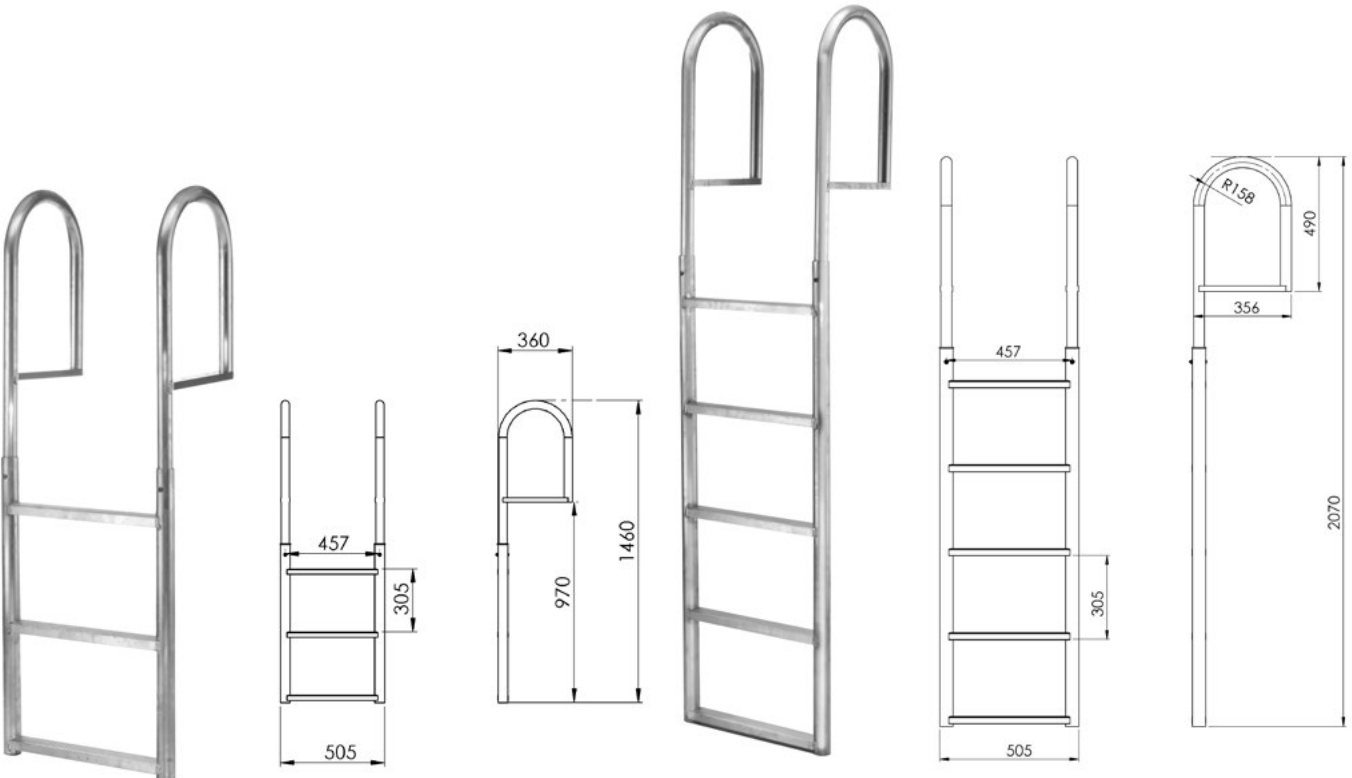

Scalette in legno di mogano

Gradini con antiscivolo. Ferramenta completamente in ottone cromato. Complete di ganci, cerniere, fermo laterale e gommini di appoggio. Adatte per scafi a motore e a vela.

Mahogany wood ladder

Antislip steps. Chromed brass hardware. Equipped with hooks, hinges, side locks and rubber grommets. This ladder is suitable for motor and sail boats.

| Articolo - Item | €/pc. | Gradini Steps | Lunghezza-Length mm. | | Larghezza max Max width mm. | Interasse tubi Tube centre distance mm. |
|-----------------|-------|---------------|----------------------|---------------|-----------------------------|---|
| | | | Aperta-Open | Chiusa-Closed | | |
| S 14 00 004 | | 4 | 910 | 500 | 300 | 305 |
| S 14 00 006 | | 6 | 1300 | 700 | 315 | 305 |



COMPLETO DI-COMLETE WITH

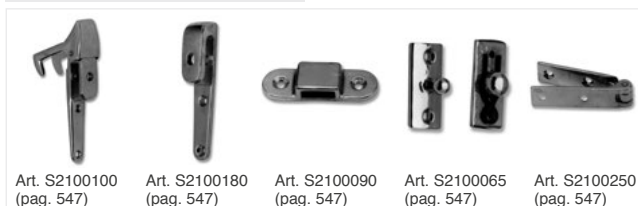

Scalette

Fabbricate in tubo anodizzato. Dotate di distanziatore a testina snodata. Bracci pieghevoli all'interno, montati su boccole in plastica antigrippaggio. Gradini in nylon antiscivolo. Molto leggera e galleggiante. Con tubi di protezione del bordo sui bracci.

Boarding ladders

Manufactured in anodized tube. Equipped with swivelling heads, foldable side rails, mounted on antiscuff plastic bushings. Antislip nylon steps. Light and floating, with protective tubes on the side rails.

| Articolo - Item | €/pc. | Gradini Steps | Ø Curvatura braccio Arm curve Ø mm. | Piedino di ricambio Spare foot | Gradino di ricambio Spare step |
|-----------------|-------|---------------|-------------------------------------|--------------------------------|--------------------------------|
| S 00 25 003 | | 3 | 180 | S2000060 | S2000300 |
| S 00 25 004 | | 4 | 180 | S2000060 | S2000300 |
| S 00 25 005 | | 5 | 180 | S2000060 | S2000300 |
| S 01 25 003 | | 3 | 260 | S2000060 | S2000300 |
| S 01 25 004 | | 4 | 260 | S2000060 | S2000300 |
| S 01 25 005 | | 5 | 260 | S2000060 | S2000300 |

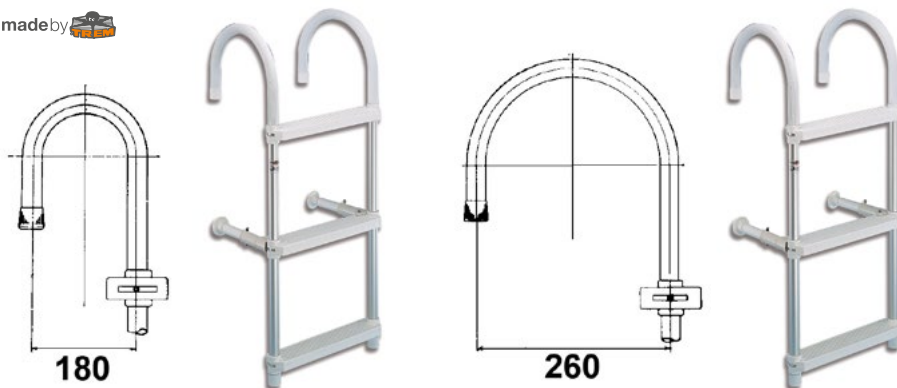

COMPLETO DI-COMLETE WITH



Scalette di prua telescopiche

Fabbricate in alluminio lucidato a specchio. Bracci girevoli da agganciare al pulpito. Gradini ovali. Puntone di appoggio alla prua.

Boarding ladders

Manufactured in anodized mirror polished anticorrosion tube. Equipped with swivelling heads, foldable side rails, mounted on antiscuff plastic bushings. Antislip nylon steps. Light and floating, with protective tubes on the side rails.

| Articolo - Item | €/pc. | Gradini Steps | Lunghezza Length mm. | Interasse tubi Tube centre distance mm. | Larghezza max Max width mm. |
|-----------------|-------|---------------|----------------------|---|-----------------------------|
| S 12 28 003 | | 3 | 850 | 270 | 290 |
| S 12 28 004 | | 4 | 1090 | 270 | 290 |

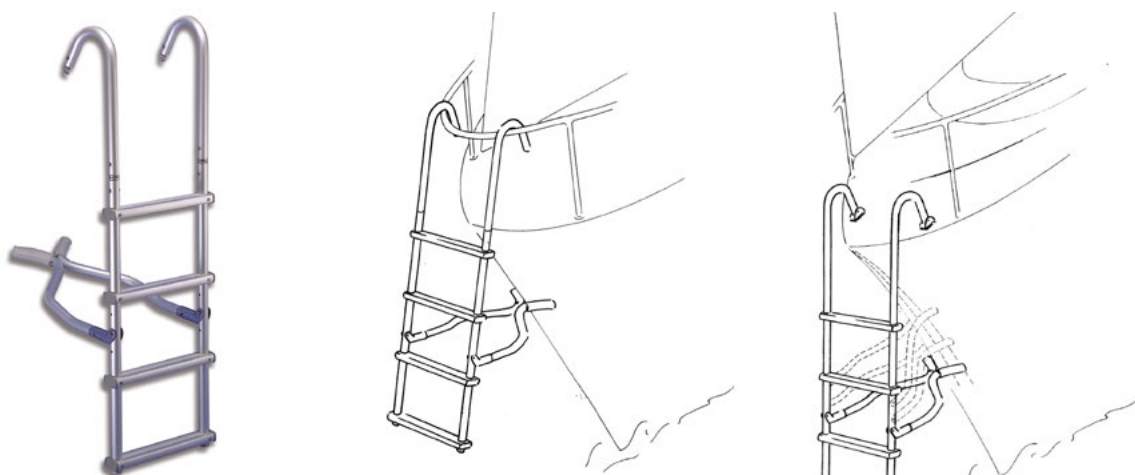



Scalette pieghevoli per specchio di poppa

Fabbricate interamente in tubo di acciaio inox Aisi 316 lucidato. Provviste di distanziali regolabili. Complete di guarnizioni e di contropiastre per il fissaggio sull'imbarcazione. Tubo Ø 25 mm.

Folding boarding ladders for transom

Manufactured in polished stainless steel pipe Aisi 316. Equipped with new shape aluminium steps that gives easy reascend on the boats. Pipe Ø 25 mm.

| Articolo - Item | €/pc. | Gradini Steps | Lunghezza Length mm. | Larghezza Width mm. | Interasse Centre distance mm. | kg. |
|-----------------|-------|---------------|----------------------|---------------------|-------------------------------|-------|
| S 07 25 003 | | 1 + 2 = 3 | 730 | 265 | 245 | 2,300 |
| S 07 25 004 | | 2 + 2 = 4 | 1030 | 265 | 245 | 2,600 |

AISI 316 made by

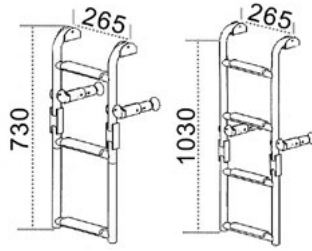

COMPLETO DI-COMLETE WITH



Art. S3007060 (pag. 546) Art. S2025120 (pag. 546) Art. S3007080 (pag. 546)

SUGGESTED ITEM

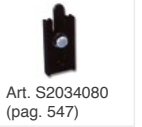

Art. S2034080 (pag. 547)



Scaletta pieghevole per specchio di poppa

Fabbricata completamente in alluminio anodizzato. Modello di dimensioni ridotte. Per specchio di poppa di gommoni e di imbarcazioni con spazi molto ristretti. Completa di attacchi.

Folding boarding ladder for transom

Manufactured in anodised aluminium. Suitable for inflatable boats with small transom. Complete with fastening set.

| Articolo - Item | €/pc. | Gradini Steps | Lunghezza Length mm. | Larghezza Width mm. | Interasse Centre distance mm. | kg. |
|-----------------|-------|---------------|----------------------|---------------------|-------------------------------|-------|
| S 11 03 076 | | 1 + 2 = 3 | 800 | 210 | 190 | 1,800 |

AISI 316 made by

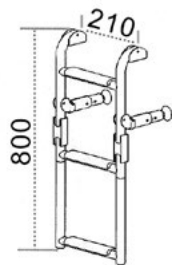

COMPLETO DI-COMLETE WITH



Art. S3007060 (pag. 546) Art. S2025120 (pag. 546) Art. S3007080 (pag. 546)

SUGGESTED ITEM

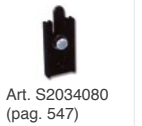

Art. S2034080 (pag. 547)



Scaletta pieghevole per specchio di poppa

Fabbricata in acciaio inox Aisi 316. Per specchio di poppa di gommoni e di imbarcazioni con spazi molto ristretti. Completa di attacchi.

Folding boarding ladder for transom

Manufactured in Aisi 316 SS. Suitable for inflatable boats with small transom. Complete with fastening set.

| Articolo - Item | €/pc. | Gradini Steps | Lunghezza Length mm. | Larghezza Width mm. | Interasse Centre distance mm. | kg. |
|-----------------|-------|---------------|----------------------|---------------------|-------------------------------|-------|
| S 11 23 003 | | 1 + 2 = 3 | 740 | 220 | 200 | 2,300 |

AISI 316 made by

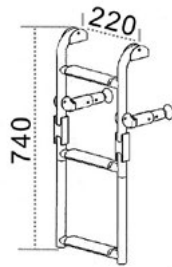

COMPLETO DI-COMLETE WITH



Art. S3007060 (pag. 546) Art. S2025120 (pag. 546) Art. S3007080 (pag. 546)

SUGGESTED ITEM

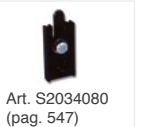

Art. S2034080 (pag. 547)



Scalette pieghevoli per specchio di poppa piccole imbarcazioni

Fabbricate in acciaio inox Aisi 316. Per specchio di poppa di gommoni e di imbarcazioni con spazi molto ristretti. Completa di attacchi.

Folding boarding ladders for transom of small leisure boats

Manufactured in Aisi 316 stainless steel. Suitable for inflatable boats with small transom. Complete with fastening set.

| Articolo - Item | €/pc. | Gradini Steps | Lunghezza Length mm. | Larghezza Width mm. | Interasse Centre distance mm. | kg. |
|-----------------|-------|---------------|----------------------|---------------------|-------------------------------|-------|
| S 11 00 003 | | 1 + 2 = 3 | 575 | 156 | 135 | 1,900 |

AISI 316 made by

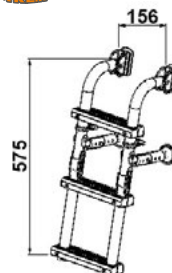

COMPLETO DI-COMLETE WITH



Art. S3007060 (pag. 546) Art. S2025120 (pag. 546) Art. S3007080 (pag. 546)

SUGGESTED ITEM

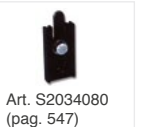

Art. S2034080 (pag. 547)

Scalette pieghevoli per specchio di poppa

Con gradini in plastica antiscivolo di forma anatomica.
 Fabbricata in tubo di acciaio inox Aisi 316 lucidato.
 Provvista di distanziali regolabili.
Tubo Ø 25 mm.

Folding boarding ladders for transom

With antisliding plastic steps.
 Manufactured in polished Aisi 316 stainless steel pipe.
 It is provided with plastic adjustable spacers.
Pipe Ø 25 mm.

| Articolo - Item | €/pc. | Gradini Steps | Lunghezza Length mm. | Larghezza Width mm. | Interasse Centre distance mm. | kg. |
|-----------------|-------|---------------|----------------------|---------------------|-------------------------------|-------|
| S 05 30 003 | | 1 + 2 = 3 | 840 | 300 | 280 | 2,200 |
| S 05 30 004 | | 2 + 2 = 4 | 1070 | 300 | 280 | 2,400 |
| S 05 30 005 | | 2 + 3 = 5 | 1335 | 300 | 280 | 2,600 |

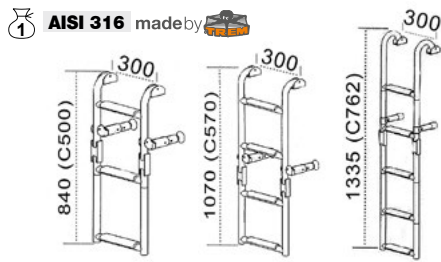

COMPLETO DI-COMLETE WITH



SUGGESTED ITEM

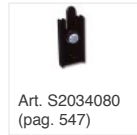

Scaletta pieghevole per specchio di poppa

Indicata per tutte le imbarcazioni con specchio di poppa di piccole dimensioni.
Tubo Ø 25 mm.

Folding boarding ladder for transom

Suitable for boats with small transom.
Pipe Ø 25 mm.

| Articolo - Item | €/pc. | Gradini Steps | Lunghezza Length mm. | Larghezza Width mm. | Interasse Centre distance mm. | kg. |
|-----------------|-------|---------------|----------------------|---------------------|-------------------------------|-------|
| S 10 25 003 | | 2 + 1 = 3 | 750 | 260 | 240 | 2,400 |

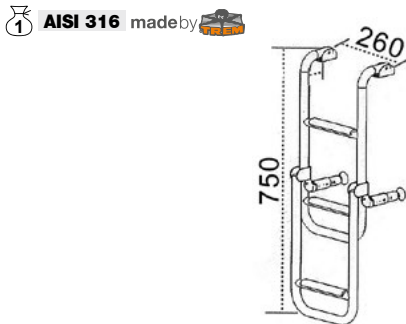

COMPLETO DI-COMLETE WITH



SUGGESTED ITEM

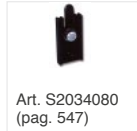

Scaletta pieghevole per specchio di poppa

Con gradini in plastica antiscivolo di forma anatomica.
 Fabbricata in tubo di acciaio inox Aisi 316 lucidato.
 Provvista di distanziali regolabili.
Tubo Ø 25 mm.

Folding boarding ladder for transom

With antisliding plastic steps.
 Manufactured in polished Aisi 316 stainless steel pipe.
 It is provided with plastic adjustable spacers.
Pipe Ø 25 mm.

| Articolo - Item | €/pc. | Gradini Steps | Lunghezza Length mm. | Larghezza Width mm. | Interasse Centre distance mm. | kg. |
|-----------------|-------|---------------|----------------------|---------------------|-------------------------------|-------|
| S 06 30 005 | | 2 + 3 = 5 | 1340 | 300 | 280 | 2,600 |

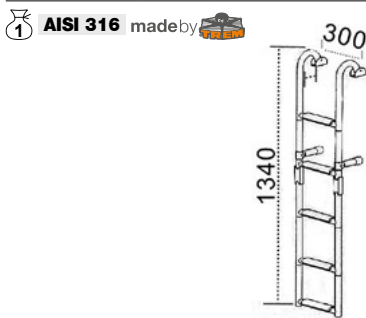

COMPLETO DI-COMLETE WITH

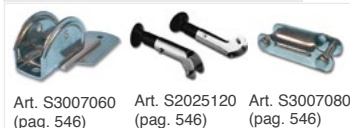

SUGGESTED ITEM

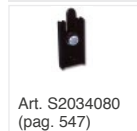

Scalette in acciaio inox Aisi 316 con gradini in legno

In acciaio inox Aisi 316 lucidato.
 Completa di guarnizioni e di contropiastre per il fissaggio.
Tubo Ø 25 mm.

Stainless steel Aisi 316 folding boarding ladders with wooden steps

Manufactured in polished Aisi 316 stainless steel.
 Equipped with adjustable spacers.
Pipe Ø 25 mm.

| Articolo - Item | €/pc. | Gradini Steps | kg. |
|-----------------|-------|---------------|-------|
| S 09 28 003 | | 2 + 1 = 3 | 2,100 |
| S 09 28 004 | | 2 + 2 = 4 | 2,800 |
| S 09 28 005 | | 3 + 2 = 5 | 3,500 |

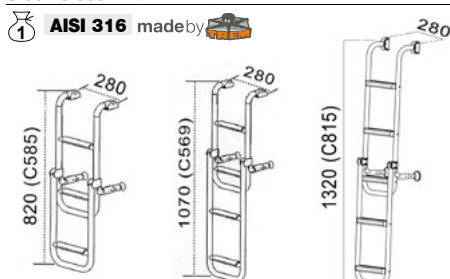

COMPLETO DI-COMLETE WITH



SUGGESTED ITEM

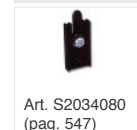

SCALETTE | LADDERS



Scalette per gommoni

Realizzate in alluminio anodizzato. Pieghevoli, molto leggere e galleggianti. Complete di moschettone inox e cima di fissaggio.

Rubber dinghy ladders

Manufactured in anodized aluminium. Folding, lightweight and floating. Equipped with stainless steel snap hook and rope.

| Articolo - Item | €/pc. | Gradini Steps | Lunghezza Length mm. | Larghezza Width mm. | Tube-Pipe Ø mm. |
|-----------------|-------|---------------|----------------------|---------------------|-----------------|
| S 11 30 003 | | 2 | 900 | 300 | 25 |
| S 11 30 004 | | 3 | 1150 | 300 | 25 |



COMPLETO DI-COMLETE WITH



Art. S3007080
(pag. 546)



Scaletta pieghevole per gommoni

Realizzate in alluminio anodizzato a tre gradini. Complete di cinghie in nylon con fibbia per il fissaggio al pagliolo. Modello universale.

Folding dinghy ladder

Manufactured in anodised aluminium, with three steps. Complete with nylon straps and buckle for floor mounting. Universal size.

| Articolo - Item | €/pc. | Gradini Steps | Lunghezza Length mm. | Larghezza Width mm. | Tube-Pipe Ø mm. |
|-----------------|-------|---------------|----------------------|---------------------|-----------------|
| S 11 03 030 | | 3 | 880 | 300 | 25 |



COMPLETO DI-COMLETE WITH



Art. S3007055
(pag. 546)



Biscagliana con gradini in plastica

In corda di levilene bianca, con gradini in policarbonato.

Temporary boarding ladder with plastic steps

Manufactured in white levilene nylon cord, with polycarbonate steps.

| Articolo - Item | €/pc. | Gradini Steps | Lunghezza Length mm. | Dimensioni gradini Step size mm. | Corda-Rope Ø mm. |
|-----------------|-------|---------------|----------------------|----------------------------------|------------------|
| S 15 09 003 | | 3 | 900 | 300x110x40 | 12 |
| S 15 09 004 | | 4 | 1100 | 300x110x40 | 12 |
| S 15 09 005 | | 5 | 1400 | 300x110x40 | 12 |



Biscagliana con gradini in legno

Modello completamente pieghevole per facilitare lo stivaggio.

Temporary boarding ladder with wooden steps

Folding and very easy to store.

| Articolo - Item | €/pc. | Gradini Steps | Lunghezza Length mm. | Larghezza Width mm. | Corda-Rope Ø mm. | kg. |
|-----------------|-------|---------------|----------------------|---------------------|------------------|-------|
| S 16 09 003 | | 3 | 860 | 300 | 12 | 1,000 |
| S 16 09 004 | | 4 | 1080 | 300 | 12 | 1,300 |

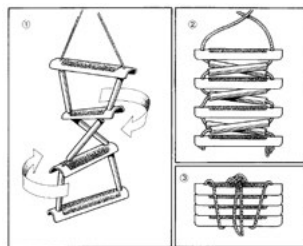

Scaletta per gommoni

Fabbricata in acciaio inox lucidato a specchio. Gradini con pedana in plastica antiscivolo. Fissaggi al pagliolo con 2 nastri regolabili. Adatta per tubolari gommoni fino a Ø 500 mm. Completa di maniglia di risalita.

Rubber dinghy ladder

Manufactured in mirror polished stainless steel. Steps with antislip plastic footboard. Fastening to the pull catch by means of 2 adjustable straps. Suitable for dinghy tubular up to Ø 500 mm. Complete with climb handle.

| Articolo - Item | €/pc. | Gradini Steps | Tubi-Tubes Ø mm. | Lunghezza-Length mm. | | Per tubolari fino a For tubular up to Ø mm. |
|-----------------|-------|---------------|------------------|----------------------|---------------|---|
| | | | | Aperta-Open | Chiusa-Closed | |
| S 11 03 050 | | 3 | 19/25/32 | 900 | 380x345 | 500 |



Plancette di poppa

Fabbricate in acciaio inox Ø 25 mm. Piattaforma in legno marino. Attacchi a U per il fissaggio allo specchio di poppa. Provviste di sostegni.

Transom platforms

Manufactured in stainless steel Ø 25 mm. Marine wood platform. U-joints for fastening to the transom. Provided with supports.

| Articolo - Item | €/pc. | A mm. | B mm. | C mm. | Sostegno Support | Mod. | Portamotore consigliato Suggested motor bracket | Scala consigliata Suggested ladder |
|-----------------|-------|-------|-------|-------|------------------|----------|---|------------------------------------|
| S 19 00 027 | | 270 | 360 | 180 | 1 Tubo Ø 25 | FILICUDI | S3000275 | S1922623 |
| S 19 00 048 | | 380 | 480 | 220 | 2 Tubi Ø 25 | LIPARI | S3000010 | S1903073 |
| S 19 55 040 | | 450 | 480 | 260 | 2 Tubi Ø 25 | PROCIDA | S3000010 | S1925003 |
| S 19 00 000 | | 600 | 550 | 260 | 2 Tubi Ø 25 | ISCHIA | S3000010 | S1925003 |
| S 26 55 130 | | 1300 | 550 | 260 | 2 Tubi Ø 25 | GIGLIO | - | S1925003 |
| S 27 55 200 | | 2000 | 550 | 260 | 4 Dist. Nylon | USTICA | - | S1925003 |
| S 27 55 230 | | 2300 | 550 | 260 | 4 Dist. Nylon | USTICA | - | S1925003 |

AISI 316 made by



COMPLETO DI-COMLETE WITH



SUGGESTED ITEM

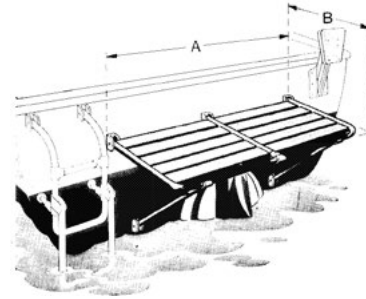

Plancetta di poppa con scaletta

Fabbricata in acciaio inox Ø 25 mm. e legno marino completa di scaletta a scomparsa con tre gradini Art. S1922623.

Transom platform with boarding ladder

Manufactured in stainless steel Ø 25 mm. and marine wood. Complete with folding boarding ladder with 3 steps Art. S1922623.

| Articolo - Item | €/pc. | A mm. | B mm. | Sostegno-Fastening |
|-----------------|-------|-------|-------|--------------------|
| S 19 02 027 | | 270 | 360 | 1 Tubo-Tube Ø 25 |

AISI 316 made by

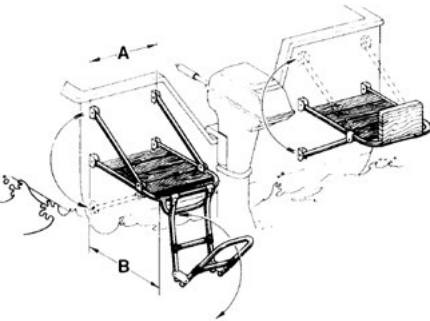

COMPLETO DI-COMLETE WITH



SUGGESTED ITEM



Plancetta di poppa con scaletta 4 gradini estraibile

Fabbricata in acciaio inox Ø 25 mm. e legno marino completa di scaletta pieghevole con quattro gradini Art. S3103004.

Transom platform with 4 steps extractable boarding ladder

Manufactured in stainless steel Ø 25 mm. and marine wood. Complete with folding boarding ladder with 4 steps Art. S3103004.

| Articolo - Item | €/pc. | A mm. | B mm. | Sostegno-Fastening |
|-----------------|-------|-------|-------|--------------------|
| S 19 45 003 | | 450 | 480 | 2 Tubi-Tubes Ø 25 |

AISI 316 made by

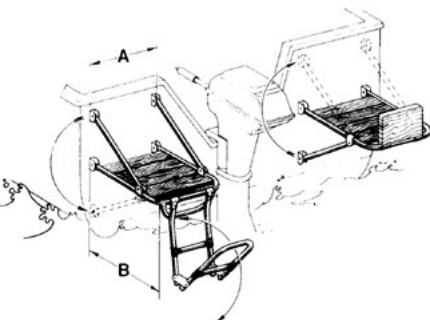

COMPLETO DI-COMLETE WITH



SUGGESTED ITEM



Attacco a mezza luna per scalette e plancette

Fabbricato in acciaio inox. Completo di viti di fissaggio e di controplacca.

| Articolo - Item | €/paio-pair | Ø mm. |
|-----------------|-------------|-------|
| S 30 07 060 | | 25 |

made by **AISI 316**

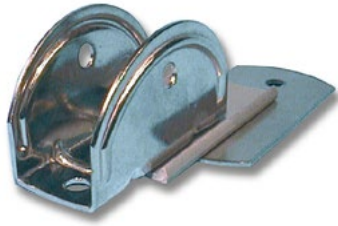

Special fastening for platforms and ladders

Manufactured in stainless steel. With fastening screws.

Snodo in acciaio inox per scalette

Articulation for boarding ladders

| Articolo - Item | €/pc. | Tubo-Pipe Ø mm. | kg. |
|-----------------|-------|-----------------|-------|
| S 30 07 080 | | 25 | 0,080 |

made by **AISI 316**



Particolare a «U» per scalette in acciaio inox

Fabbricato in acciaio inox Aisi 316 completo di viti per il fissaggio.

| Articolo - Item | €/pc. | Per tubo-For pipe Ø mm. | kg. |
|-----------------|-------|-------------------------|-------|
| S 20 07 055 | | 25 | 0,065 |

made by **AISI 316**



Special fastening form «U» for stainless steel boarding ladder

Manufactured in Aisi 316 stainless steel with fastening screws.

Fascetta in acciaio inox per plancette

Per fissare oggetti sulle battaglieole.

Fastening clamp for platform plancette

For fastening on rails.

| Articolo - Item | €/pc. | Per tubo-For pipe Ø mm. | kg. |
|-----------------|-------|-------------------------|-------|
| S 30 07 025 | | 25 | 0,030 |



Gradino di risalita

Fabbricato in acciaio inox Aisi 316 lucidato completo di gradino in teak.

| Articolo - Item | €/pc. | mm. |
|-----------------|-------|------------|
| S 08 25 013 | | 270x130x25 |

NEW **AISI 316**



Step for boarding ladder

Manufactured in polished Aisi 316 stainless steel with wooden Teak step.

Gradino di risalita

Fabbricato in acciaio inox. Tubo Ø 25 mm. con gradino ribattuto per comodità di risalita.

| Articolo - Item | €/pc. | mm. |
|-----------------|-------|----------|
| S 08 25 130 | | 245x135H |

AISI 316 made by



Step for boarding ladder

Manufactured in stainless steel with rivetted step for easy boarding.

Serie distanziali in acciaio inox

Distanziali fabbricati in tubo di acciaio inox.

| Articolo - Item | €/pair | Lunghezza-Length mm. |
|-----------------|--------|----------------------|
| S 20 25 120 | | 120 |

AISI 316 made by



Spacers for ladders

Manufactured in stainless steel pipe.

Distanziali

Per tubo tondo.

Spacers for ladders

For round pipe.

| Articolo - Item | €/pair |
|-----------------|--------|
| S 20 00 060 | |

made by



Raccordo a «T» in nylon per scalette

Nylon connection for boarding ladder

Fabbricato in nylon di prima qualità.

Manufactured in high quality nylon.

| Articolo - Item | €/pc. | Per tubo-For pipe Ø mm. | kg. |
|-----------------|-------|-------------------------|-------|
| S 20 04 065 | | 25 | 0,055 |



Gancio di sicurezza

Safety hook

| Articolo - Item | €/pc. |
|-----------------|-------|
| S 21 00 100 | |



Gancio semplice

Standard hook

| Articolo - Item | €/pc. |
|-----------------|-------|
| S 21 00 180 | |



Piastrina per gancio

Plate for hook

| Articolo - Item | €/pc. |
|-----------------|-------|
| S 21 00 090 | |



Bottoni di chiusura

Buttons

Composto da m aschio e femmina.

Set complete with male and female.

| Articolo - Item | €/Kit |
|-----------------|-------|
| S 21 00 065 | |



Cerniera

Hinge

| Articolo - Item | €/pc. |
|-----------------|-------|
| S 21 00 250 | |



Gradini in legno per scale

Wooden steps for boarding ladder

| Articolo - Item | €/pc. | Lunghezza-Length mm. |
|-----------------|-------|----------------------|
| S 11 00 260 | | 218 |
| S 11 00 300 | | 252 |



Kit attacchi rapidi per scalette

Fastening kit for ladders

Realizzati in plastica e ottone.
Kit composto da 2 piastre e 2 staffe.

Manufactured in plastic and brass.
Kit complete with 2 plates and 2 brackets.

| Articolo - Item | €/pc. | Descrizione-Description |
|-----------------|-------|---|
| S 20 34 080 | | Per scale-For ladders: S0928003-S0928004-S0928005-S0630005-S1025003-S0530003-S0530004-S0530005-S1100003-S1100004-S1123003-S1103076-S0725003-S0725004 |



RICAMBI PER SCALE E PLANCETTE | SPARE PARTS FOR LADDERS AND PLATFORMS

Scaletta per plancette

Platform boarding ladder

| Articolo - Item | €/pc. | Ø mm. | Gradini Steps | Lunghezza Length mm. | Larghezza Width mm. |
|-----------------|-------|-------|---------------|----------------------|---------------------|
| S 19 22 623 | | 25 | 3 | 620 | 220 |



COMPLETO DI-COMLETE WITH

Art. S3007080
(pag. 546)

Scalette per plancette

Platform boarding ladders

| Articolo - Item | €/pc. | Ø mm. | Gradini Steps | Lunghezza Length mm. | Larghezza Width mm. |
|-----------------|-------|-------|---------------|----------------------|---------------------|
| S 19 03 073 | | 25 | 3 | 610 | 240 |
| S 19 25 003 | | 25 | 3 | 730 | 280 |



COMPLETO DI-COMLETE WITH

Art. S3007080
(pag. 546)

Portamotore per plancette

Platform motor bracket

| Articolo - Item | €/pc. | A mm. | B mm. | C mm. |
|-----------------|-------|-------|-------|-------|
| S 30 00 010 | | 250 | 250 | 200 |

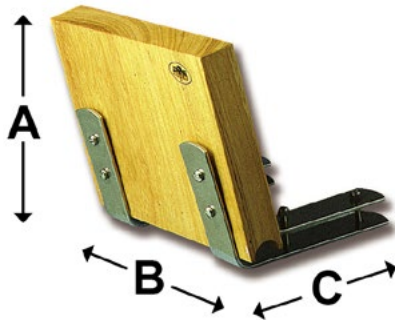

Sostegni distanziatori

Articulated plates

| Articolo - Item | €/pc. | Materiale Material | Per tubo interno For pipe Ø mm. | Base Ø mm. |
|-----------------|-------|--------------------|---------------------------------|------------|
| S 30 10 600 | | Nylon | 23 | 70 |
| S 30 07 600 | | Aisi 316 | 22 | 70 |



Gradino di ricambio

Spare step

Fabbricato in materiale plastico.

Manufactured in plastic material.

| Articolo - Item | €/pc. | kg. |
|-----------------|-------|-------|
| S 20 00 300 | | 0,200 |



Tappo in plastica

Plastic cap

| Articolo - Item | €/pc. | €/Box | kg. |
|-----------------|-------|-------|-----|
| S 20 00 022 | | | 200 |



Kit porta SUP e porta passerella

Il kit T-Rack consente di fissare la tavola da SUP o la passerella fuori bordo.
 Fissaggio al corrimano per mezzo di morsetti in ABS. Adatto per tubi di Ø tra 22 mm. e 30 mm.
 Il kit è dotato di 2 bracci in alluminio, morsetti e di corda elastica per il fissaggio.
 Indicato per passerelle o tavole da surf di spessore fino a 18 cm.

T-Rack kit with Stand Up Paddle (SUP) and gangway support

The T-Rack allows you to keep your SUP or gangway out of the boat.
 Easy connection to the handrail stanchions thanks to ABS double clamps.
 Suitable for pipe Ø from 22 mm. to 30 mm. Aluminum support arms (2x), clamps and elastic rope for securing the board or the gangway. Suitable for SUP or gangway up to 18 cm. thick.

Articolo - Item €/Kit
 O 08 40 020

↑ cm.
 40x20x4



Kit cinghia porta SUP e porta passerella

Il Kit T-Belt consente di fissare la tavola da SUP al tientibene o ai candelieri della barca sia essa a vela o motore grazie ai morsetti regolabili 360° e realizzati in ABS ad alta resistenza. Adatto a tubi di diametro tra 22 mm e 30 mm. Il kit è composto da due coppie di morsetti in ABS bianco con relative cinghie fornite di chiusura a scatto

Belt kit with Stand Up Paddle (SUP) and gangway support

The T-Belt allows you to fix your SUP board to the boat handrail or to the boat stanchions, suitable for both power or sailing boat thanks to the 360° rotating clamps made in high resistance ABS. Suitable for pipes diameter from 22 mm to 30 mm.
 The kit includes 2 pair of white clamps with belts and snap closure system.

Articolo - Item €/Kit Lunghezza cadauna cinghia-Belt length cm.
 O 08 03 033 180

Larghezza cinghia-Belt width mm.
 25

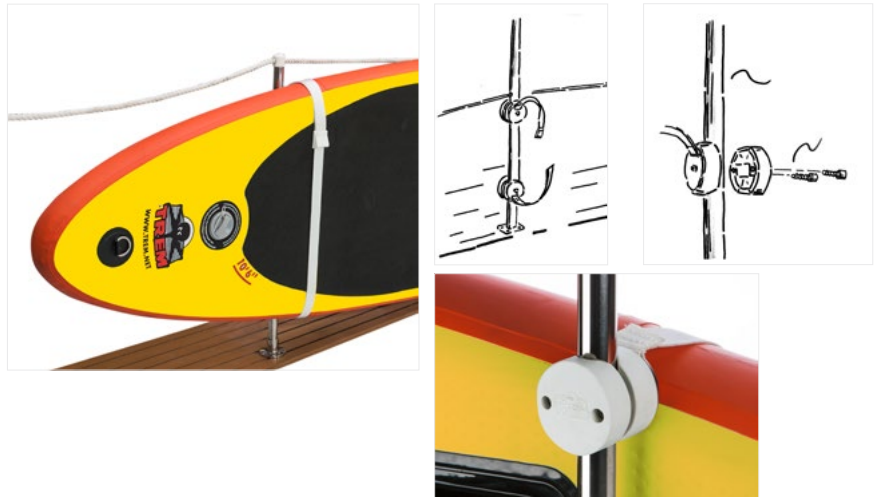

ROLL-BARS

Roll-bar «Targa» con fissaggio sull'imbarcazione

Fabbricato in tubo di acciaio inox Aisi 316 con rifiniture in legno. Indispensabile per l'applicazione dell'antenna radar, luci di via, ecc.
 Fissaggio semplice e funzionale per mezzo di attacchi snodati e telescopici.

Roll-bar «Targa» for boats

Manufactured in stainless steel pipe Aisi 316 with wooden finishing.
 Very easy mounting through articulated and telescopic joints.

| Articolo - Item | €/pc. | Larghezza-Width mm. | H mm. | kg. |
|-----------------|-------|---------------------|---------|-------|
| O 20 70 140 | | 1600-1800 | 820-880 | 6.500 |



Roll-bar abbattibile «Mega» telescopico in larghezza

Fabbricato in tubo di acciaio inox Aisi 316. Indispensabile per l'applicazione dell'antenna radar, luci di via, ecc.
 Fissaggio semplice e funzionale.

Folding roll-bar «Mega» telescopic width

Manufactured in stainless steel pipe Aisi 316 with wooden finishing.
 Very easy mounting through articulated and telescopic joints.

| Articolo - Item | €/pc. | H mm. | Larghezza-Width mm. | Tubo-Pipe Ø mm. | kg. |
|-----------------|-------|-------|---------------------|-----------------|--------|
| O 20 16 215 | | 1200 | 1650-2300 | 40 | 10,930 |



GRUETTE | DAVITS

Coppia gruette porta-tender con bracci girevoli

Fabbricate in tubo di acciaio inox Aisi 316 lucidato di spessore 2 mm. e con basi di alluminio anodizzato. base ø 185 mm. Provviste di cime, carrucola, bitta, bozzello, grilli e moschettoni inox.

Davit for tender with swivelling arms

Manufactured in polished stainless steel pipe Aisi 316 2 mm. thick and with anodised aluminium base. Fitted with hoist, stainless steel blocks and stainless steel hooks.

| Articolo - Item | €/paio-pair | Tubo-Pipe Ø mm. | A mm. | B mm. | Portata Max load kg. | kg. |
|-----------------|-------------|-----------------|-------|-------|----------------------|--------|
| O 17 40 120 | | 40 | 700 | 850 | 100 | 12,000 |

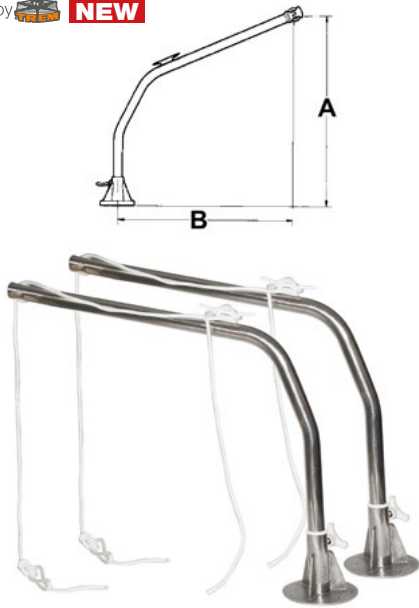

Coppia gruette per l'applicazione in coperta

Fabbricate in tubo di acciaio inox Aisi 316 lucidato. Munite di boccole da incasso con guida interna e contropiasta. Provviste di cime, carrucole, di bitte, bozzelli e moschettoni inox.

Davits for tender

Manufactured in polished Aisi 316 stainless steel. Swivelling arms. Flushmount installation. Supplied with ropes, pulley, cleats, blocks and stainless steel snap hooks.

| Articolo - Item | €/paio-pair | Tubo-Pipe Ø mm. | A mm. | B mm. | C mm. | D mm. | Portata Max load kg. | kg. |
|-----------------|-------------|-----------------|-------|-------|-------|-------|----------------------|-------|
| O 17 40 090 | | 40 | 900 | 700 | 130 | 45 | 130 | 8,600 |

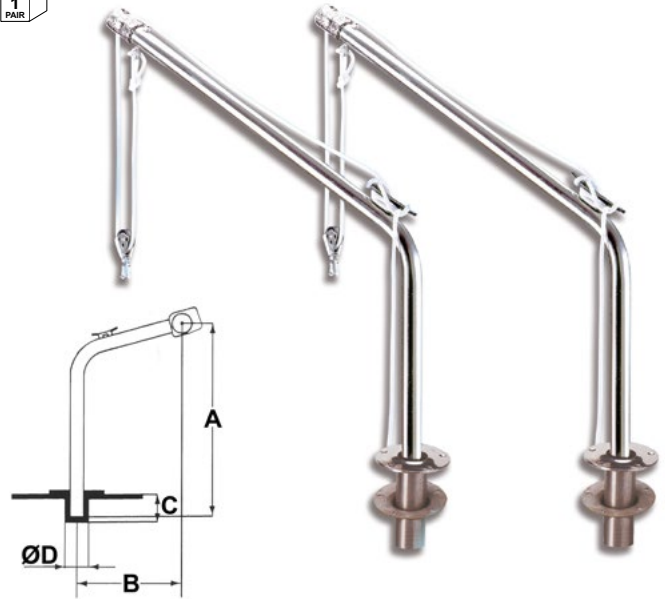

Gruetta singola piroettante per sollevamento motori

Fornita completa di cima, carrucola, bitta, bozzello e moschettoni inox.

Swivelling davits in stainless steel for engine lift

Supplied with blocks, snap links and rail fastening.

| Articolo - Item | €/pc. | Tubo-Pipe Ø mm. | A mm. | B mm. | Portata Max load kg. | kg. |
|-----------------|-------|-----------------|-------|-------|----------------------|-------|
| O 17 30 140 | | 40 | 1400 | 500 | 55 | 9,000 |

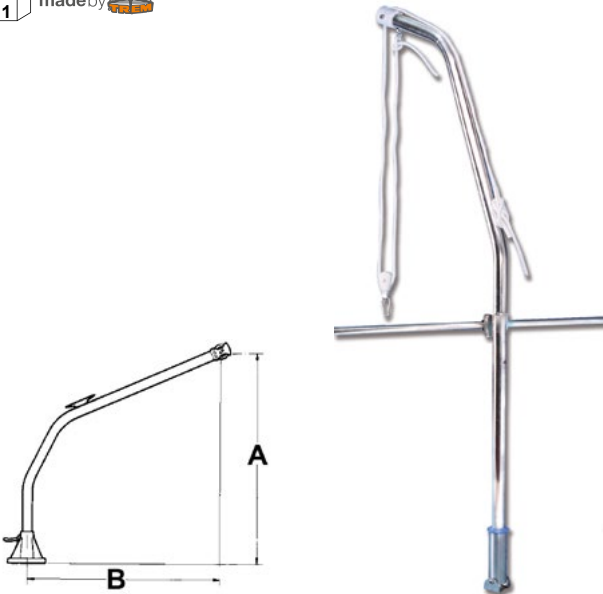

Gruetta singola per sollevamento motori in acciaio inox Aisi 316

Swivelling davits in stainless steel Aisi 316 for engine lift

| Articolo - Item | €/pc. | Tubo-Pipe Ø mm. | A mm. | B mm. | C mm. | D mm. | Portata Max load kg. | kg. |
|-----------------|-------|-----------------|-------|-------|-------|-------|----------------------|-------|
| N 06 30 105 | | 40 | 1050 | 750 | 150 | 45 | 30 | 3,000 |

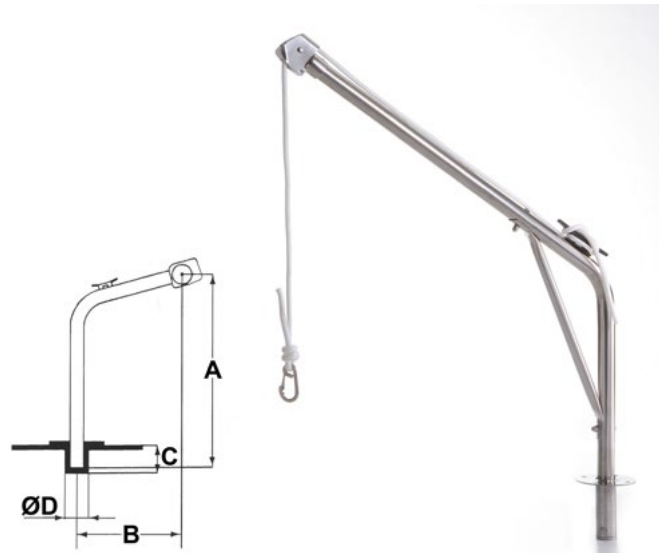

«Power lift» imbracatura di sollevamento per motori fuoribordo con maniglia superiore

Universale per tutti i motori fuoribordo. Indispensabile per spostare il fuoribordo dal Pram al pulpito di poppa e viceversa. Fabbricato in cinghia di poliestere.

«Power lift» outboard engine lifting harness with upper handle

This handy item securely attaches to outboards providing a safe and secure handle for carrying, hoisting and moving heavy, cumbersome motors.

| Articolo - Item | €/pc. | Portata max Max load kg. |
|-----------------|-------|--------------------------|
| N 06 30 050 | | 50 |



VISIT OUR NEW WEB SITE



WWW.TREM.NET



FORNELLI E PIANI COTTURA «CAN» | «CAN» HOB UNITS



| | |
|----------------------|--------|
| Larghezza-Width mm. | 380 |
| Profondità-Depth mm. | 280 |
| Altezza-Height mm. | 80 |
| Peso-Weight kg. | 8 |
| Fuochi-Burners | 1A-1SR |

**Piano cottura a gas in vetro
cristallo da incasso**

Completo di termocoppia.

**Rectangular glass top
2 burners A-SR**

The arrangement of the burners allows the simultaneous use of large pans.

| Articolo - Item | €/pc. | Fuochi Burners | Mod. | Watt |
|-----------------|-------|-------------------|--------|-----------|
| Z 08 00 351 | | 2 | PV1351 | 1000+1750 |

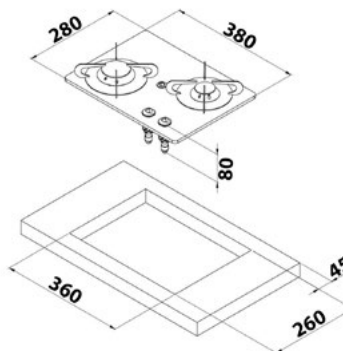

Can

**SUGGESTED ITEM**Art. Z0801371
(pag. 555)

| | |
|----------------------|-----|
| Larghezza-Width mm. | 290 |
| Profondità-Depth mm. | 325 |
| Altezza-Height mm. | 80 |
| Peso-Weight kg. | 5 |
| Fuochi-Burners | 1SR |

**Piano cottura a gas in vetro
cristallo da incasso**

Completo di termocoppia.

**Square glass top
1 burner SR**

The maximum of functional quality: a compact 1 burner hob. With thermocouple.

| Articolo - Item | €/pc. | Fuochi Burners | Mod. | Watt |
|-----------------|-------|-------------------|--------|------|
| Z 08 00 320 | | 1 | PV1320 | 1900 |

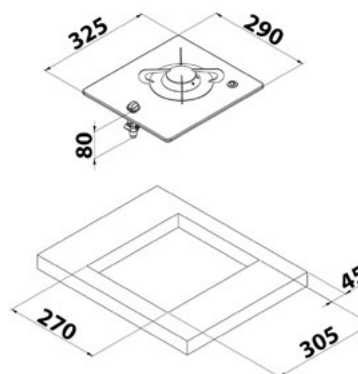

Can

**SUGGESTED ITEM**Art. Z0801370
(pag. 555)

| | |
|----------------------|-----|
| Larghezza-Width mm. | 200 |
| Profondità-Depth mm. | 365 |
| Altezza-Height mm. | 80 |
| Peso-Weight kg. | 5 |
| Fuochi-Burners | 1SR |

**Piano cottura a gas in vetro
cristallo da incasso**

Completo di termocoppia.

**Rectangular glass top
1 burner SR**

Complete with thermocouple.

| Articolo - Item | €/pc. | Fuochi Burners | Mod. | Watt |
|-----------------|-------|-------------------|--------|------|
| Z 08 00 350 | | 1 | PV1350 | 1750 |

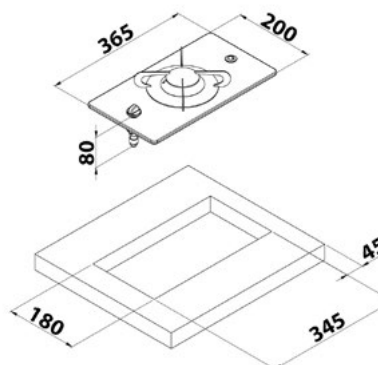

Can

**SUGGESTED ITEM**Art. Z0801370
(pag. 555)

Piano cottura a incasso

Completo di termocoppia.
Versione super compatta alimentata a gas.

Gas hob unit 1 burner SR

Complete with thermocouple.
Super compact version. Gas propeller.

| Articolo - Item | €/pc. | Fuochi Burners | Mod. | Watt |
|-----------------|-------|----------------|--------|------|
| Z 08 01 320 | | 1 | PC1320 | 1750 |



SUGGESTED ITEM

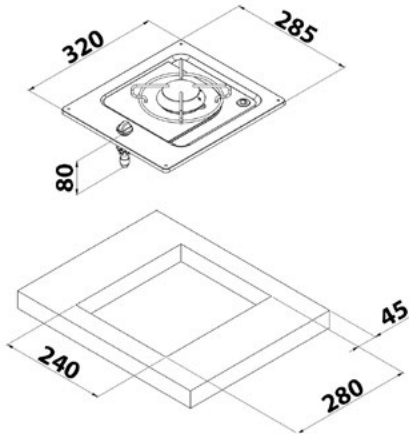

| | |
|----------------------|-----|
| Larghezza-Width mm. | 285 |
| Profondità-Depth mm. | 320 |
| Altezza-Height mm. | 80 |
| Peso-Weight kg. | 2,2 |
| Fuochi-Burners | 1SR |

Piano cottura a incasso

Completo di termocoppia.
Versione super compatta alimentata a gas.

Gas hob unit 2 burners SR

Complete with thermocouple.
Super compact version. Gas propeller.

| Articolo - Item | €/pc. | Fuochi Burners | Mod. | Watt |
|-----------------|-------|----------------|--------|--------|
| Z 08 01 321 | | 2 | PC1321 | 1750x2 |



SUGGESTED ITEM

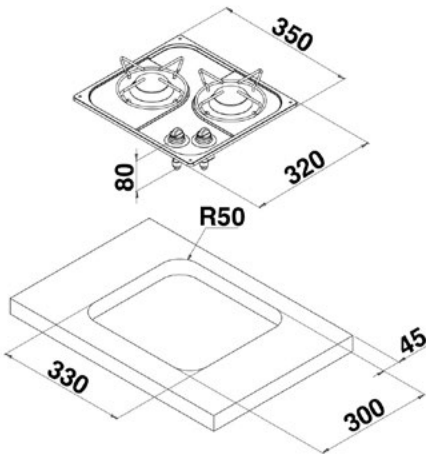

| | |
|----------------------|-----|
| Larghezza-Width mm. | 350 |
| Profondità-Depth mm. | 320 |
| Altezza-Height mm. | 80 |
| Peso-Weight kg. | 3 |
| Fuochi-Burners | 2SR |

Piano cottura in vitroceramica a induzione

Il sistema ad induzione comporta un elevato risparmio energetico, in quanto si scalda solo la superficie a contatto della pentola. Struttura in acciaio inox. Controllo touch screen.

Electric glass-ceramic stove

Built-in ceramic stove with 2 radiating 220V plates with "touch screen" control. Stainless steel frame.

| Articolo - Item | €/pc. | Piastre Plates | Mod. | Watt | Volts |
|-----------------|-------|----------------|--------|-----------|---------|
| Z 08 11 356 | | 2 | PT1356 | 1300+2200 | 220/240 |

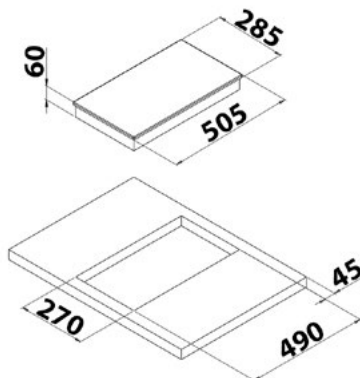

| | |
|---------------------------|--|
| Larghezza-Width mm. | 285 |
| Profondità-Depth mm. | 505 |
| Altezza-Height mm. | 60 |
| Peso-Weight kg. | 5 |
| Cooking zone-Zone cottura | Zona 1 Ø 145mm 1200W Zona 2 Ø 210mm 1600W |



| | |
|----------------------|--------|
| Larghezza-Width mm. | 765 |
| Profondità-Depth mm. | 355 |
| Altezza-Height mm. | 100+50 |
| Peso-Weight kg. | 6 |
| Fuochi-Burners | 1A-1SR |

Piano cottura con coperchio in vetro temperato fumé

Completo di lavello e rubinetto con miscelatore acqua calda/fredda. Alimentata a gas.

Combination gas stove with built-in sink & glass-tempered cover

Manufactured in stainless steel, 2-burner gas supply, with right-hand rectangular sink, tap with hot/cold water mixer. Gas propeller.

| Articolo - Item | €/pc. | Fuochi Burners | Mod. | Watt |
|-----------------|-------|----------------|--------|-----------|
| Z 08 01 400 | | 2 | FL1770 | 1000+1750 |

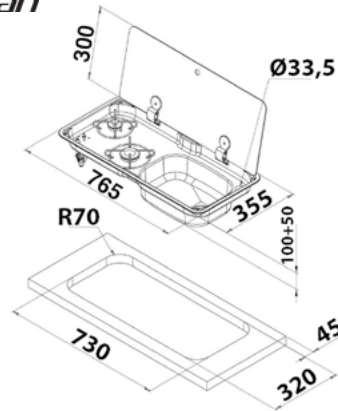

SUGGESTED ITEM



Art. Z0801487 (pag. 555)

Art. Z0801371 (pag. 555)



| | |
|----------------------|--------|
| Larghezza-Width mm. | 530 |
| Profondità-Depth mm. | 325 |
| Altezza-Height mm. | 120+50 |
| Peso-Weight kg. | 5,5 |
| Fuochi-Burners | 1SR |

Piano cottura con coperchio in vetro temperato fumé

Completo di lavello e rubinetto con miscelatore acqua fredda. Alimentata a gas.

Combination gas stove with built-in sink & glass-tempered cover

Manufactured in stainless steel, 2-burner gas supply, with right-hand rectangular sink, tap with cold water mixer. Gas propeller.

| Articolo - Item | €/pc. | Fuochi Burners | Mod. | Watt |
|-----------------|-------|----------------|--------|------|
| Z 08 01 323 | | 1 | FL1323 | 1750 |

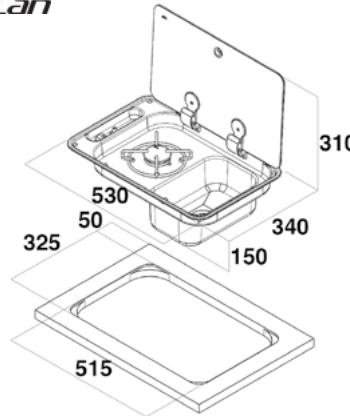

SUGGESTED ITEM



Art. Z0801487 (pag. 555)

Art. Z0801370 (pag. 555)

Piano cottura ribaltabile a cerniera nel lavello

In acciaio inox lucidato. Completo di rubinetto pieghevole e coperchio in vetro temperato.

Combination gas stove with retractable sink

Stainless steel hinged stove with sink and folding cold water tap. Tempered glass top.

| Articolo - Item | €/pc. | Fuochi Burners | Mod. | Watt |
|-----------------|-------|----------------|--------|------|
| Z 08 01 701 | | 1 | LC1701 | 1750 |



SUGGESTED ITEM



Art. Z0820090 (pag. 421)

Art. Z0801370 (pag. 555)

Art. N0100315 (pag. 415)

| | |
|----------------------|-----|
| Larghezza-Width mm. | 690 |
| Profondità-Depth mm. | 340 |
| Altezza-Height mm. | 180 |
| Peso-Weight kg. | 6 |
| Fuochi-Burners | 1SR |

Piano cottura ribaltabile a cerniera nel lavello

In acciaio inox lucidato. Completo di rubinetto pieghevole e coperchio in vetro temperato.

Combination gas stove with retractable sink

Stainless steel hinged stove with sink and folding cold water tap. Tempered glass top.

| Articolo - Item | €/pc. | Fuochi Burners | Mod. | Watt |
|-----------------|-------|----------------|--------|------|
| Z 08 01 710 | | 1 | LC1710 | 1750 |

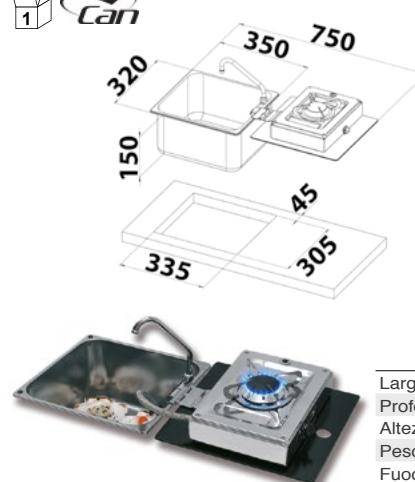

SUGGESTED ITEM

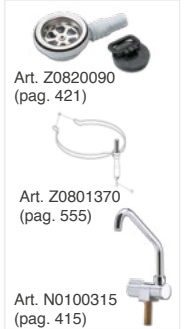

Art. Z0820090 (pag. 421)

Art. Z0801370 (pag. 555)

Art. N0100315 (pag. 415)

| | |
|----------------------|-----|
| Larghezza-Width mm. | 750 |
| Profondità-Depth mm. | 320 |
| Altezza-Height mm. | 150 |
| Peso-Weight kg. | 6 |
| Fuochi-Burners | 1SR |

Piano cottura esterno in acciaio inox

Alimentato a gas.

Outdoor stainless steel gas stove

Gas propeller.

| Articolo - Item | €/pc. | Fuochi Burners | Mod. | Watt |
|-----------------|-------|----------------|--------|------|
| Z 08 01 330 | | 1 | FN1330 | 1750 |

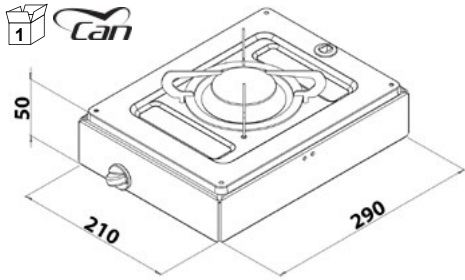

SUGGESTED ITEM

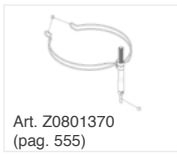

| | |
|----------------------|-----|
| Larghezza-Width mm. | 210 |
| Profondità-Depth mm. | 290 |
| Altezza-Height mm. | 90 |
| Peso-Weight kg. | 2 |
| Fuochi-Burners | 1SR |

Piano cottura esterno in acciaio inox

Alimentato a gas.

Outdoor stainless steel gas stove

Gas propeller.

| Articolo - Item | €/pc. | Fuochi Burners | Mod. | Watt |
|-----------------|-------|----------------|--------|-----------|
| Z 08 01 332 | | 2 | FN1332 | 1900+1000 |

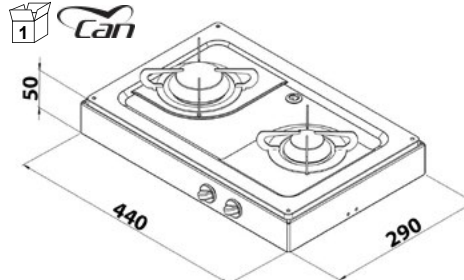

SUGGESTED ITEM



| | |
|----------------------|--------|
| Larghezza-Width mm. | 440 |
| Profondità-Depth mm. | 290 |
| Altezza-Height mm. | 90 |
| Peso-Weight kg. | 4 |
| Fuochi-Burners | 1A-1SR |

Barbecue elettrico vetro-ceramico in acciaio inox

| Articolo - Item | €/pc. | Mod. | Volts |
|-----------------|-------|--------|-------|
| Z 08 01 328 | | PB1328 | 220 |

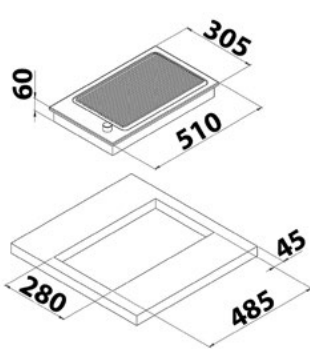

Built-in stove with stainless steel structure, barbeque in striped glass-ceramic

| | |
|----------------------|-------|
| Larghezza-Width mm. | 305 |
| Profondità-Depth mm. | 510 |
| Altezza-Height mm. | 60 |
| Peso-Weight kg. | 5,5 |
| Potenza-Power | 2,5KW |

Barbecue elettrico in acciaio inox

| Articolo - Item | €/pc. | Mod. | Volts |
|-----------------|-------|--------|-------|
| Z 08 01 327 | | PB1327 | 220 |

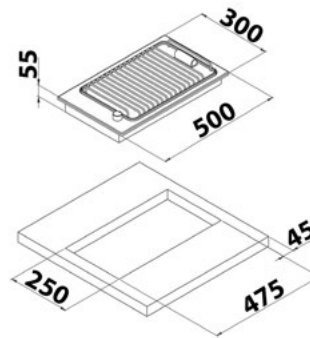

Built-in stove with stainless steel structure

| | |
|----------------------|-------|
| Larghezza-Width mm. | 300 |
| Profondità-Depth mm. | 500 |
| Altezza-Height mm. | 55 |
| Peso-Weight kg. | 7 |
| Potenza-Power | 2,4KW |

Fermapentola a colonna 1 fuoco 1 burner pan holder

| Articolo - Item | €/pc. |
|-----------------|-------|
| Z 08 01 370 | |

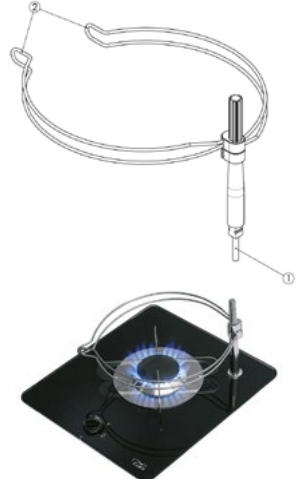

Fermapentola a colonna 2 fuochi 2 burners pan holder

| Articolo - Item | €/pc. |
|-----------------|-------|
| Z 08 01 371 | |



Fermapentola sfilabile Removable pan holder

| Articolo - Item | €/pc. |
|-----------------|-------|
| Z 08 01 350 | |



Rubinetto elettrico 12V Electric tap 12V

| Articolo - Item | €/pc. |
|-----------------|-------|
| Z 08 01 487 | |

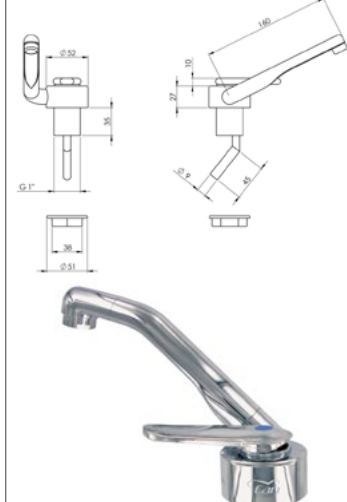

Piano cottura 1 fuoco «Atoll» 1 Burner gas stove «Atoll»

Articolo - Item €/pc.
Z 08 00 614



Dimensioni incasso
Built-in size



COMPLETE WITH



Art. Z0800015
(pag. 560)



| | |
|---|-----------------------------------|
| Fuochi-Burners | 1 |
| Potenza-Power | 2KW |
| Energia-Energy | Butano / Propano 28-30 mbar |
| Consumo-Consumption | 145 g/h |
| Sicurezza-Safety device | Termocoppia-Thermocouple |
| Fermapentola-Pan holders | 1 set (2 pcs.) |
| Materiale-Material | Acciaio inox-Stainless steel 304L |
| Finitura-Finish | Brillante-Bright |
| Dim. prodotto-Product size mm. (H/L/D) | 121x290x352 |
| Dim. scatola-Packaging size mm. (H/L/D) | 132x300x383 |
| Peso netto-Net weight kg. | 2 |
| Peso lordo-Gross weight kg. | 2,9 |
| Marcatura-Marking | CE - AGA - USCG |
| Garanzia-Warranty | 2 anni-years |

Piano cottura 2 fuochi con snodo cardanico «Duo» 2 Burners gimble gas stove «Duo»

Articolo - Item €/pc.
Z 08 81 624



Dimensioni incasso
Built-in size



COMPLETE WITH



Art. Z0800015
(pag. 560)



| | |
|---|-----------------------------------|
| Fuochi-Burners | 2 |
| Potenza-Power | 1,75KW - 2,5KW |
| Energia-Energy | Butano / Propano 28-30 mbar |
| Consumo-Consumption | 309 g/h |
| Sicurezza-Safety device | Termocoppia-Thermocouple |
| Fermapentola-Pan holders | 1 set (2 pcs.) |
| Materiale-Material | Acciaio inox-Stainless steel 304L |
| Finitura-Finish | Brillante-Bright |
| Dim. prodotto-Product size mm. (H/L/D) | 246x511x334 |
| Dim. scatola-Packaging size mm. (H/L/D) | 100x505x365 |
| Peso netto-Net weight kg. | 3 |
| Peso lordo-Gross weight kg. | 4 |
| Marcatura-Marking | CE - AGA - USCG |
| Garanzia-Warranty | 2 anni-years |

Piano in vitroceramico ad incasso «Tobago» 1 fuoco «Tobago»

Articolo - Item €/pc.
Z 08 01 220



Dimensioni incasso
Built-in size



| | |
|---|--|
| Fuochi-Burners | 1x14 cm. |
| Potenza-Power | 1x1,2KW |
| Energia-Energy | 220/240V - 50/60Hz |
| Consumo-Consumption | 5 Amp |
| Sicurezza-Safety device | Non overheating safety, residual heat ind. |
| Materiale-Material | Vetroceramica-Vitrocera 4 mm. |
| Finitura-Finish | Nero-Black |
| Dim. prodotto-Product size mm. (H/L/D) | 135x305x305 |
| Dim. incasso- Built-in size mm. (H/L/D) | 103x285x285 |
| Dim. scatola-Packaging size mm. (H/L/D) | 140x470x380 |
| Peso netto-Net weight kg. | 3,5 |
| Peso lordo-Gross weight kg. | 4,12 |
| Marcatura-Marking | CE |
| Garanzia-Warranty | 2 anni-years |

Piano in vitroceramico ad incasso «Trinidad» 3 fuochi «Trinidad»

Articolo - Item €/pc.
Z 08 03 220



Dimensioni incasso
Built-in size



| | |
|---|--|
| Fuochi-Burners | 3x14 cm. |
| Potenza-Power | 3x1,2KW |
| Energia-Energy | 220/240V - 50/60Hz |
| Consumo-Consumption | 15 Amp |
| Sicurezza-Safety device | Non overheating safety, residual heat ind. |
| Materiale-Material | Vetroceramica-Vitrocera 4 mm. |
| Finitura-Finish | Nero-Black |
| Dim. prodotto-Product size mm. (H/L/D) | 135x533x457 |
| Dim. incasso- Built-in size mm. (H/L/D) | 103x512x435 |
| Dim. scatola-Packaging size mm. (H/L/D) | 180x492x660 |
| Peso netto-Net weight kg. | 9 |
| Peso lordo-Gross weight kg. | 9,84 |
| Marcatura-Marking | CE |
| Garanzia-Warranty | 2 anni-years |

Piano cottura da incasso a gas 1 fuoco «Santorini» | **1 Burner gas built-in hob «Santorini»**

Articolo - Item €/pc.
Z 08 01 190



Dimensioni incasso
Built-in size

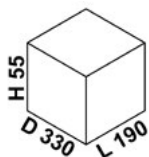

COMPLETE WITH



Art. Z0800015
(pag. 560)



| | |
|---|-----------------------------------|
| Fuochi-Burners | 1 |
| Potenza-Power | 1,75KW |
| Energia-Energy | Butano / Propano 28-30 mbar |
| Consumo-Consumption | 127 g/h |
| Sicurezza-Safety device | Termocoppia-Thermocouple |
| Fermapentola-Pan holders | 1 set (2 pcs.) |
| Materiale-Material | Acciaio inox-Stainless steel 304L |
| Finitura-Finish | Brillante-Bright |
| Dim. prodotto-Product size mm. (H/L/D) | 124x210x350 |
| Dim. incasso- Built-in size mm. (H/L/D) | 55x190x330 |
| Dim. scatola-Packaging size mm. (H/L/D) | 132x300x383 |
| Peso netto-Net weight kg. | 1,8 |
| Peso lordo-Gross weight kg. | 2,45 |
| Marcatura-Marking | CE - AGA - USCG |
| Garanzia-Warranty | 2 anni-years |

Piano cottura da incasso a gas 2 fuochi «Hydra» | **2 Burners gas built-in hob «Hydra»**

Articolo - Item €/pc.
Z 08 81 432



Dimensioni incasso
Built-in size



COMPLETE WITH



Art. Z0800015
(pag. 560)



| | |
|---|-----------------------------------|
| Fuochi-Burners | 2 |
| Potenza-Power | 1,75KW - 2,5KW |
| Energia-Energy | Butano / Propano 28-30 mbar |
| Consumo-Consumption | 309 g/h |
| Sicurezza-Safety device | Termocoppia-Thermocouple |
| Accensione-Ignition | Optional |
| Materiale-Material | Acciaio inox-Stainless steel 304L |
| Finitura-Finish | Brillante-Bright |
| Dim. prodotto-Product size mm. (H/L/D) | 77x472x342 |
| Dim. incasso- Built-in size mm. (H/L/D) | 73x468x338 |
| Dim. scatola-Packaging size mm. (H/L/D) | 105x526x450 |
| Peso netto-Net weight kg. | 2,9 |
| Peso lordo-Gross weight kg. | 3,65 |
| Marcatura-Marking | CE - AGA - USCG |
| Garanzia-Warranty | 2 anni-years |

Piano cottura da incasso a gas 3 fuochi «Kos» | **3 Burners gas built-in hob «Kos»**

Articolo - Item €/pc.
Z 08 81 433



Dimensioni incasso
Built-in size



COMPLETE WITH



Art. Z0800015
(pag. 560)



| | |
|---|-----------------------------------|
| Fuochi-Burners | 3 |
| Potenza-Power | 1KW - 1,75KW - 2,5KW |
| Energia-Energy | Butano / Propano 28-30 mbar |
| Consumo-Consumption | 382 g/h |
| Sicurezza-Safety device | Termocoppia-Thermocouple |
| Accensione-Ignition | Optional |
| Materiale-Material | Acciaio inox-Stainless steel 304L |
| Finitura-Finish | Brillante-Bright |
| Dim. prodotto-Product size mm. (H/L/D) | 77x468x388 |
| Dim. incasso- Built-in size mm. (H/L/D) | 35x450x370 |
| Dim. scatola-Packaging size mm. (H/L/D) | 105x526x450 |
| Peso netto-Net weight kg. | 3,8 |
| Peso lordo-Gross weight kg. | 4,5 |
| Marcatura-Marking | CE - AGA - USCG |
| Garanzia-Warranty | 2 anni-years |



Cucina a gas 2 fuochi «Grand Large»

Cucina a gas butano-propano omologata CE, provvista di due fuochi e griglia fermapentole regolabile. Fornita di serie con termocoppia di sicurezza, griglie inox porta pentole, leva di bloccaggio sportello forno e supporto cardanico (basculante) laterale per scaffa a vela.

2 Burners gas cooker «Grand Large»

CE approved, thermocouple safety, complete with oven door locking lever and tilting system for sailing boats. Electronic ignition.

| Articolo - Item | €/pc. | Mod. | Fuochi-Burners |
|-----------------|-------|---------------------------------|----------------|
| Z 08 08 420 | | Forno-Oven | 2 |
| Z 08 18 420 | | Forno con grill-Oven with grill | 2 |



Dimensioni incasso
Built-in size

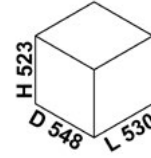

COMPLETE WITH



| | Z 08 08 420 | Z 08 18 420 |
|---|---|--|
| Fuochi-Burners | 2 / Forno-Oven | 2 / Forno con grill-Oven with grill |
| Volume forno-Oven volume | 24 L | 19 L |
| Potenza-Power | 1,75KW - 2,5KW / 1,8KW | 1,75KW - 2,5KW / 1,5KW / 1,35KW |
| Energia-Energy | Butano / Propano 28-30 mbar | |
| Consumo-Consumption | 440 g/h | 418 g/h |
| Sicurezza-Safety device | Termocoppia-Thermocouple | |
| Fermapentola-Pan holders | 2 set | |
| Accensione-Ignition | Elettronica-Electronic | |
| Materiale-Material | Acciaio inox/Forno smaltato-Stainless steel/Enameled oven | Tutto acciaio inox-All stainless steel |
| Finitura-Finish | Brillante-Bright | |
| Dim. prodotto-Product size mm. (H/L/D) | 470x515x447 | |
| Dim. incasso- Built-in size mm. (H/L/D) | 523x530x548 | |
| Dim. scatola-Packaging size mm. (H/L/D) | 560x510x510 | |
| Peso netto-Net weight kg. | 24,2 | 23,9 |
| Peso lordo-Gross weight kg. | 26,7 | 26,4 |
| Marcatura-Marking | CE - AGA - USCG | |
| Garanzia-Warranty | 2 anni-years | |



Cucina a gas 3 fuochi «Grand Large»

Cucina a gas butano-propano omologata CE, provvista di due fuochi e griglia fermapentole regolabile. Fornita di serie con termocoppia di sicurezza, griglie inox porta pentole, leva di bloccaggio sportello forno e supporto cardanico (basculante) laterale per scaffa a vela.

3 Burners gas cooker «Grand Large»

CE approved, thermocouple safety, complete with oven door locking lever and tilting system for sailing boats. Electronic ignition.

| Articolo - Item | €/pc. | Mod. | Fuochi-Burners |
|-----------------|-------|---------------------------------|----------------|
| Z 08 14 334 | | Forno-Oven | 3 |
| Z 08 14 604 | | Forno con grill-Oven with grill | 3 |



Dimensioni incasso
Built-in size



COMPLETE WITH



| | Z 08 14 334 | Z 08 14 604 |
|---|---|--|
| Fuochi-Burners | 3 / Forno-Oven | 3 / Forno con grill-Oven with grill |
| Volume forno-Oven volume | 24 L | 19 L |
| Potenza-Power | 1KW - 1,75KW - 2,5KW / 1,8KW | 1KW - 1,75KW - 2,5KW / 1,5KW / 1,35KW |
| Energia-Energy | Butano / Propano 28-30 mbar | |
| Consumo-Consumption | 513 g/h | 491 g/h |
| Sicurezza-Safety device | Termocoppia-Thermocouple | |
| Fermapentola-Pan holders | 2 set | |
| Accensione-Ignition | Elettronica-Electronic | |
| Materiale-Material | Acciaio inox/Forno smaltato-Stainless steel/Enameled oven | Tutto acciaio inox-All stainless steel |
| Finitura-Finish | Brillante-Bright | |
| Dim. prodotto-Product size mm. (H/L/D) | 470x515x446 | |
| Dim. incasso- Built-in size mm. (H/L/D) | 523x530x548 | |
| Dim. scatola-Packaging size mm. (H/L/D) | 560x510x510 | |
| Peso netto-Net weight kg. | 24,5 | 24,2 |
| Peso lordo-Gross weight kg. | 27 | 26,6 |
| Marcatura-Marking | CE - AGA - USCG | |
| Garanzia-Warranty | 2 anni-years | |

Cucina a gas 2 fuochi
«Gascogne»

Costruita interamente in acciaio inox. Forno interno in acciaio inox ad alta resistenza. Fornita di serie con griglia e fermapentole regolabile in acciaio inox. Accensione elettronica. Provvista di supporto laterale cardanico per scafi a vela.

2 Burners gas cooker
«Gascogne»

CE approved, thermocouple safety, complete with oven door locking lever and tilting system for sailing boats. Electronic ignition.

| Articolo - Item | €/pc. | Mod. | Fuochi-Burners |
|-----------------|-------|---------------------------------|----------------|
| Z 08 08 823 | | Forno-Oven | 2 |
| Z 08 18 634 | | Forno con grill-Oven with grill | 2 |



Dimensioni incasso
Built-in size



COMPLETE WITH



Art. Z0800015
(pag. 560)



| | Z 08 08 823 | Z 08 18 634 |
|---|--|--|
| Fuochi-Burners | 2 / Forno-Oven | 2 / Forno con grill-Oven with grill |
| Volume forno-Oven volume | 24 L | 19 L |
| Potenza-Power | 1,75KW - 2,5KW / 1,8KW | 1,75KW - 2,5KW / 1,5KW / 1,35KW |
| Energia-Energy | | Butano / Propano 28-30 mbar |
| Consumo-Consumption | 440 g/h | 418 g/h |
| Sicurezza-Safety device | | Termocoppia-Thermocouple |
| Fermapentola-Pan holders | | 2 set |
| Accensione-Ignition | | Elettronica-Electronic |
| Materiale-Material | Acciaio inox/Forno smaltato/Maniglia in legno Stainless steel/Enameled oven/Wooden handle | Tutto acciaio inox/ Maniglia in legno All stainless steel/Wooden handle |
| Finitura-Finish | | Nero-Black |
| Dim. prodotto-Product size mm. (H/L/D) | | 470x515x446 |
| Dim. incasso- Built-in size mm. (H/L/D) | | 523x530x548 |
| Dim. scatola-Packaging size mm. (H/L/D) | | 560x510x510 |
| Peso netto-Net weight kg. | 24,2 | 23,9 |
| Peso lordo-Gross weight kg. | 26,7 | 26,4 |
| Marchatura-Marking | | CE - AGA - USCG |
| Garanzia-Warranty | | 2 anni-years |

Cucina a gas 3 fuochi
«Gascogne»

Costruita interamente in acciaio inox. Forno interno in acciaio inox ad alta resistenza. Fornita di serie con griglia e fermapentole regolabile in acciaio inox. Accensione elettronica. Provvista di supporto laterale cardanico per scafi a vela.

3 Burners gas cooker
«Gascogne»

CE approved, thermocouple safety, complete with oven door locking lever and tilting system for sailing boats. Electronic ignition.

| Articolo - Item | €/pc. | Mod. | Fuochi-Burners |
|-----------------|-------|---------------------------------|----------------|
| Z 08 18 134 | | Forno-Oven | 3 |
| Z 08 18 334 | | Forno con grill-Oven with grill | 3 |



Dimensioni incasso
Built-in size



COMPLETE WITH



Art. Z0800015
(pag. 560)



| | Z 08 18 134 | Z 08 18 334 |
|---|--|--|
| Fuochi-Burners | 3 / Forno-Oven | 3 / Forno con grill-Oven with grill |
| Volume forno-Oven volume | 24 L | 19 L |
| Potenza-Power | 1KW - 1,75KW - 2,5KW / 1,8KW | 1KW - 1,75KW - 2,5KW / 1,5KW / 1,35KW |
| Energia-Energy | | Butano / Propano 28-30 mbar |
| Consumo-Consumption | 513 g/h | 491 g/h |
| Sicurezza-Safety device | | Termocoppia-Thermocouple |
| Fermapentola-Pan holders | | 2 set |
| Accensione-Ignition | | Elettronica-Electronic |
| Materiale-Material | Acciaio inox/Forno smaltato/Maniglia in legno Stainless steel/Enameled oven/Wooden handle | Tutto acciaio inox/ Maniglia in legno All stainless steel/Wooden handle |
| Finitura-Finish | | Nero-Black |
| Dim. prodotto-Product size mm. (H/L/D) | | 470x515x446 |
| Dim. incasso- Built-in size mm. (H/L/D) | | 523x530x548 |
| Dim. scatola-Packaging size mm. (H/L/D) | | 560x510x510 |
| Peso netto-Net weight kg. | 24,5 | 24,2 |
| Peso lordo-Gross weight kg. | 27 | 26,7 |
| Marchatura-Marking | | CE - AGA - USCG |
| Garanzia-Warranty | | 2 anni-years |



Cucina a gas 3 fuochi «Bretagne»

Cucina a gas butano-propano omologata CE. Provvista di tre fuochi. Con forno inox e grill.

3 Burners gas cooker «Bretagne»

CE approved, complete with 3 burners, stainless steel oven and grill.

| Articolo - Item | €/pc. | Mod. | Fuochi-Burners |
|-----------------|-------|---------------------------------|----------------|
| Z 08 00 233 | | Forno con grill-Oven with grill | 3 |



Dimensioni incasso
Built-in size

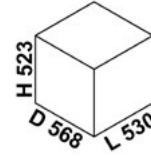

COMPLETE WITH



Art. Z0800015
(pag. 560)

Z 08 00 233

| | |
|---|---|
| Fuochi-Burners | 3 / Forno termostatico con grill-Thermostatic oven with grill |
| Volume forno-Oven volume | 19 L |
| Potenza-Power | 2 x 1,75KW - 2,7KW / 1,5KW / 1,35KW |
| Energia-Energy | Butano / Propano 28-30 mbar |
| Consumo-Consumption | 560 g/h |
| Sicurezza-Safety device | Termocoppia-Thermocouple |
| Fermapentola-Pan holders | 3 set |
| Accensione-Ignition | Elettronica-Electronic |
| Materiale-Material | Acciaio inox/Forno inox/Acciaio zincato-Stainless steel/Stainless steel oven/Galvanised steel |
| Finitura-Finish | Brillante-Bright |
| Dim. prodotto-Product size mm. (H/L/D) | 480x515x563 |
| Dim. incasso- Built-in size mm. (H/L/D) | 523x530x568 |
| Dim. scatola-Packaging size mm. (H/L/D) | 560x530x660 |
| Peso netto-Net weight kg. | 30,5 |
| Peso lordo-Gross weight kg. | 33,15 |
| Marcatura-Marking | CE - AGA - USCG |
| Garanzia-Warranty | 2 anni-years |

Kit morsetti piani cottura

Composto da 4 morsetti.

Clamps kit for hob units

Kit with 4 clamps.



| Articolo - Item | €/Kit | Pcs./Kit |
|-----------------|-------|----------|
| Z 08 00 015 | | 4 |



Eventuali richieste speciali verranno accettate solo se il Cliente indicherà **CODICE CUCINA, ANNO DI PRODUZIONE** e **FOTO** del ricambio in questione.

Any special requests will be accepted only if the Customer will indicate **KITCHEN CODE, PRODUCTION YEAR** and **PHOTO** of the spare part in question.

Regolatore gas orizzontale bassa pressione

Omologato IMQ.
Entrata: dado 25 mm. attacco «Italia».
Uscita: portagomma Ø 10 mm.

Horizontal gas regulator low pression

IMQ approved.
IN: nut 25 mm. «Italia»-type connection.
OUT: hose nozzle Ø 10 mm.

| Articolo - Item | €/pc. | Portata max Max load kg/h | Taratura fissa Fixed calibration |
|-----------------|-------|------------------------------|-------------------------------------|
| L 23 00 300 | | 1 | PU/mbar 30 |



Regolatore gas verticale bassa pressione

Omologato IMQ.
Entrata: dado 25 mm. attacco «Italia».
Uscita: portagomma Ø 10 mm.

Vertical gas regulator low pression

IMQ approved.
IN: nut 25 mm. «Italia»-type connection.
OUT: hose nozzle Ø 10 mm.

| Articolo - Item | €/pc. | Portata max Max load kg/h | Taratura fissa Fixed calibration |
|-----------------|-------|------------------------------|-------------------------------------|
| L 23 00 301 | | 1 | PU/mbar 30 |



Regolatore gas orizzontale bassa pressione

Omologato IMQ.
Entrata: dado 25 mm. attacco «Italia».
Uscita: portagomma Ø 10 mm.

Horizontal gas regulator low pression

IMQ approved.
IN: nut 25 mm. «Italia»-type connection.
OUT: hose nozzle Ø 10 mm.

| Articolo - Item | €/pc. | Portata max Max load kg/h | Taratura regolabile Adjustable calibration |
|-----------------|-------|------------------------------|---|
| L 23 00 500 | | 1 | PU/mbar 20-60 |



Regolatore gas bassa pressione attacco «Camping Gaz»

Uscita: portagomma Ø 10 mm.

Low pression gas regulator «Camping Gaz» connection

OUT: hose nozzle Ø 10 mm.

| Articolo - Item | €/pc. | Portata max Max load kg/h | Taratura variabile Variable calibration |
|-----------------|-------|------------------------------|--|
| L 23 00 400 | | 0,8 | PU/mbar 28-50 |



Regolatore gas bassa pressione attacco «Camping Gaz»

Uscita: portagomma Ø 10 mm.

Low pression gas regulator «Camping Gaz» connection

OUT: hose nozzle Ø 10 mm.

| Articolo - Item | €/pc. | Portata max Max load kg/h | Taratura fissa Fixed calibration |
|-----------------|-------|------------------------------|-------------------------------------|
| L 23 00 402 | | 0,8 | PU/mbar 30 |



Rubinetto d'inversione manuale per bombole GPL

Con attacco «Italia».

Hand inversion tap for GPL cylinder

With «Italia»-type connection.

| Articolo - Item | €/pc. |
|-----------------|-------|
| L 23 15 000 | |



ACCESSORI GAS | GAS ACCESSORIES

Rubinetto con sfiato

Per bombole attacco «Italia».

Vent tap

For cylinders with «Italia»-type connection.

| Articolo - Item | €/pc. |
|-----------------|-------|
| L 23 04 900 | |



Rubinetto con sfiato

Per bombole attacco «Camping Gaz».

Vent tap

For cylinders with «Camping Gaz» connection.

| Articolo - Item | €/pc. |
|-----------------|-------|
| L 23 04 800 | |



Rubinetto senza sfiato

Per bombole attacco «Camping Gaz».

Tap

For cylinders with «Camping Gaz» connection.

| Articolo - Item | €/pc. |
|-----------------|-------|
| L 23 04 700 | |



Mini centralina con regolatore

Idonea per il collegamento in parallelo di 2 bombole GPL. Con valvole di accesso di flusso e 2 manichette Flex da 50 cm.

Mini control unit with controller

Suitable for parallel connection of 2 GPL cylinders. With flow access valves and 2 Flex hoses 50 cm.

| Articolo - Item | €/pc. | Portata max Max load kg/h | Taratura variabile Variable calibration |
|-----------------|-------|---|--|
| L 23 10 302 | | 4 | mbar 30 |
| L 23 06 228 | | Raccordo con ogive e ghiera per connettere il kit regolatore Connection with ogives and ring nuts to connect the regulator kit | |



L2310302



L2306228

Manichetta Flex da 50 cm. con tubo in gomma rivestito da treccia metallica

Per bombole GPL.

Flex hose 50 cm. with wire-coated rubber pipe

Suitable for GPL cylinders.

| Articolo - Item | €/pc. |
|-----------------|-------|
| L 23 09 801 | |



Guarnizione in Salpha

Per regolatore GPL.

Salpha gasket

Suitable for GPL regulator.

| Articolo - Item | €/pc. | €/Box |
|-----------------|-------|-------|
| L 23 08 600 | | |



Guarnizione in NBR

Per regolatore GPL. Gomma nera.

NBR gasket

Suitable for GPL regulator. Black rubber.

| Articolo - Item | €/pc. | €/Box |
|-----------------|-------|-------|
| L 23 08 601 | | |



Raccordo di riempimento

Per bombole da campeggio attacco «Italia».
For cylinders with «Italia»-type connection.

| Articolo - Item | €/pc. |
|-----------------|-------|
| L 23 12 400 | |



Indicatore livello gas Propano/Butano nelle bombole

Con attacco magnetico. Ideale per bombole da 2 a 5 kg.
With magnetic connection. For cylinders 2-5 kg.

| Articolo - Item | €/pc. |
|-----------------|-------|
| L 23 00 049 | |



Level gauge

Chiave per regolatore Regulator key

Con dado da 25 mm. attacco «Italia».
With nut 25 mm. «Italia»-type connection.

| Articolo - Item | €/pc. |
|-----------------|-------|
| L 23 11 100 | |



Raccordi ottone femmina

Female brass joints

| Articolo - Item | €/pc. | Mod. |
|-----------------|-------|--|
| L 23 07 300 | | Bombola Italia per maschio bombola tedesca |
| L 23 07 301 | | Bombola tedesca per maschio bombola Italia |



L2307300



L2307301

Tubo GPL Ø 8x13 mm. IMQ

GPL hose Ø 8x13 mm. IMQ

| Articolo - Item | €/Rotolo-Reel | Rotolo-Reel mt. |
|-----------------|---------------|-----------------|
| L 23 08 502 | | 100 |



Bombola 400 ml.

Per rivelazione fughe di gas.

| Articolo - Item | €/pc. |
|-----------------|-------|
| L 23 22 503 | |



Gas seeker 400 ml.

For gas leak detection.

Indicatore livello per bombole

Per bombole da campeggio attacco «Italia».

| Articolo - Item | €/pc. |
|-----------------|-------|
| L 23 00 050 | |



Level gauge for gas cylinder

For cylinders with «Italia»-type connection.



Fornello portatile «Devil»

Fornello con accensione piezoelettrica integrata e bruciatori in alluminio. Flusso del gas regolabile. Completo di pratica valigetta di trasporto. Funzionamento con cartucce gas. Senza termocoppia.

«Devil» Portable gas cooker

Hotplate with integrated piezoelectric ignition and aluminium burners. Adjustable gas flux. Complete with small transport case. Without flame failure device.

| Articolo - Item | €/pc. | mm. | Energia Energy | Potenza Power | kg. |
|-----------------|-------|-------------|----------------|---------------|------|
| Z 08 07 013 | | 340x280x120 | 30 mbar | 2,5KW | 2,00 |



NEW



Doppio grill «Devil»

Fornello gas a cartuccia a 2 fuochi con piastra grill in fusione di alluminio.

«Devil» double grill

2-flame cartridge gas stove and grill with cast-aluminum grill plate.

| Articolo - Item | €/pc. | mm. | Potenza Power | kg. |
|-----------------|-------|---|---------------|------|
| Z 08 07 018 | | 625x255xH130 + Piastra/Plate 445x240xH45 | 2,9KW | 7,40 |



NEW

Griglia per fornello «Devil»

«Devil» grill plate

| Articolo - Item | €/pc. | Ø mm. | kg. |
|-----------------|-------|-------|------|
| Z 08 07 019 | | 310 | 0,40 |



NEW



«Powergaz 227»

Bomboletta gas propano/butano valvolata. Conforme alla normativa UN 2037.

«Powergaz 227»

Threaded gas cartridge with propane/butane filling. In conformity with UN 2037.

| Articolo - Item | €/pc. | M.O. | Master | kg. |
|-----------------|-------|------|--------|-------|
| Z 08 07 021 | | 4 | 228 | 0,227 |



NEW



AREA DIDATTICA | EDUCATIONAL AREA

CUCINARE CON IL GAS

Cucinare con il gas all'aperto è di norma semplice, facile e pulito. Ci sono comunque alcune importanti regole da non dimenticare:

1. È vietato introdurre bombole a gas negli aerei.
2. Verificare che a destinazione siano acquistabili delle bombole a gas adatte.
3. Con l'aumentare del livello del mare diminuisce l'efficienza dei fornelli a gas.
4. Anche temperature sotto zero riducono la capacità di apparecchi a gas.
5. Usare sempre un paravento.
6. Durante la cottura usare sempre un coperchio, per evitare la dispersione del calore.

COOKING WITH GAS

Cooking with gas outdoors is usually simple, easy and clean. However, there are some important rules to remember:

1. It is forbidden to introduce gas cans on aircraft.
2. Be sure that suitable gas cans can be purchased at the destination.
3. With increasing sea levels the efficiency of gas stoves decreases.
4. Even sub-zero temperatures reduce the capacity of gas appliances.
5. Always use a screen.
6. Always use a lid when cooking to avoid heat dispersion.

Mini lavatrice compatta

Modello ideale per nautica.
Cestello in polipropilene trasparente.

Mini washing machine

Suitable for leisure boating.
Drum in transparent polypropylene.

| Articolo - Item | €/pc. | mm. | Consumo Consumption Watt | Caratteristiche Features |
|-----------------|-------|-------------|--------------------------|--------------------------|
| Z 08 91 913 | | 365x344x476 | 10 | 1,8 kg.-230V-50Hz |



GHIACCIAIE PORTATILI | ICE BOXES

Ghiacciaia portatile

Ideale per conservare alimenti pescati o come vasche per contenere esche vive. Realizzata in ABS resistente agli urti e ai raggi UV. Interno in materiale plastico inodore. Può essere utilizzata anche come seduta.

Icebox and seat

Suitable for storage of fish or living bait. Made of shockproof and UV resistant ABS. Inside made of odourless plastic material. Can be used as a seat.

| Articolo - Item | €/pc. | Capacità Capacity Lt. | mm. | Durata freddo ore Cold length hours |
|-----------------|-------|-----------------------|-------------|-------------------------------------|
| D 43 36 000 | | 36 | 500x305x408 | 72 |



Ghiacciaia portavivande

Sacca in nylon con anima in PVC. Resistente cinghia in PE. Facilmente riducibile e comoda da stivare.

Portable icebox

Nylon bag and PVC core. High resistance belt manufactured in PE. Easy folding system for a comfortable stowage.

| Articolo - Item | €/pc. | Capacità Capacity Lt. | H mm. | Ø mm. | pcs. | kg. |
|-----------------|-------|-----------------------|-------|-------|------|-------|
| P 00 20 033 | | 20 | 330 | 300 | 5 | 0,630 |



Frigo-congelatore portatile a pozzetto

Carcassa in tecnopolimero. Intercapedine schiumata con microcelle di produzione tedesca che ne garantiscono l'isolamento. Compressore DANFOSS con controllo elettronico integrato. Provvisto di Digital Touch Screen. Doppio cestello interno. Doppia maniglia per facilitarne il trasporto. Fusibile intercambiabile da 15A. Può funzionare a 12V/24V/100-240V. Provvisto di adattatori vari. Triplo uso per barca, motorhome o casa. Luce interna. Regolazione della temperatura da -18°C a +10°C. Provvisto di trasformatore con presa 220V a parete e completo di cavo accendisigari da 1,50 mt.

Portable fridge/freezer

Polymer housing. Foam cavity with German production microcells for a better insulation. Designed for outdoor use and to withstand shocks. Universal 12V/24V/100-240V supply. Provided with different adapters. With Digital Touch Screen. Fuse 15A. Suitable for boating and motorhome. Internal lighting. Temperature regulation from -18°C to +10°C. Equipped with electrical transformer with 220V wall socket and complete with cigarette lighter cable 1,50 mt.

| Articolo - Item | €/pc. | Lt. | Consumo-Consumption Watt | mm. | kg. |
|-----------------|-------|-----|--------------------------|----------------|-------|
| D 43 40 000 | | 40 | 60 | H442xL654xP345 | 15,00 |

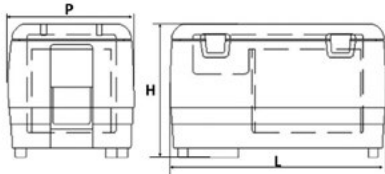



Ferma-oggetti

Ferma-oggetti versatile e innovativo. Ideale per bloccare piatti, libri e altri oggetti durante la navigazione. Staffa in alluminio e braccio in plastica indurita.

Stopper

Innovative multi-purpose holder. Ideal for keeping plates and items in plates as you travel. Support made in aluminium and handle in sturdy plastic.

| Articolo - Item | €/pc. | ↑ mm. |
|-----------------|-------|---------|
| Z 08 25 200 | | 250x200 |



Scolapiatti

Draining board

| Articolo - Item | €/pc. | ↑ mm. | kg. |
|-----------------|-------|---------|-------|
| D 27 32 030 | | 320x300 | 0,513 |



Sottobicchieri

Pratici sottobicchieri per calici da vino in silicone con supporto metallico. Colori assortiti.

Coasters

Practical coasters for silicone wine glasses with metal support. Assorted colors.

| Articolo - Item | €/Box | Ø mm. |
|-----------------|-------|-------|
| D 27 75 000 | | 75 |



Stuoia antiscivolo

Resistente e lavabile fino a 30°C. Tagliabile a piacere.

Antisliding mat

Resistant and washable up to 30°C. Can be cut at any size.

| Articolo - Item | €/pc. | ↑ cm. | Mod. |
|-----------------|-------|--------|----------|
| D 27 50 150 | | 50x150 | 100% PVC |



Bicchieri in vetro con decoro marino

Yachting motif glass

| Articolo - Item | €/pc. | €/Box | Mod. | Ø mm. | H mm. |
|-----------------|-------|-------|--------|-------|-------|
| D 17 00 130 | | | Sherry | 50 | 58 |



Batteria di pentole «Academy»

Popote di ottima qualità con pratico design salvaspazio. Pentole e coperchi in acciaio inox con fondo termico multistrato. Adatti per gas, piastra elettrica e vetroceramica a induzione.

Cookware «Academy»

Top quality popote with practical space-saving design. Pans and lids in stainless steel with multilayer thermal bottom. Suitable for gas, electric plate and glass-ceramic hob.

Articolo - Item €/Kit
D 21 22 008

kg.
3,00

1 KIT **AISI 316** **NEW**

KIT 8+1 COMPLETO DI-COMPLETE WITH

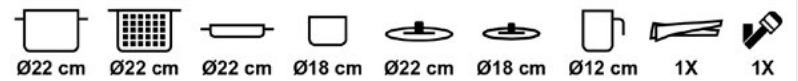

Batteria di pentole «Skipper»

Bellissima linea di popote salvaspazio con corpo in solido alluminio. Innovativo rivestimento interno antiaderente e manici in metallo con rivestimento in silicone isolante. Adatta per uso su fornelli a gas ed elettrico.

Cookware «Skipper»

Beautiful line of space-saving popote with strong aluminum body. Innovative non-stick interior lining and metal handles with insulating silicone coating. Suitable for gas and electric cookers.

Articolo - Item €/Kit
D 21 24 009

kg.
2,75

1 KIT **NEW**

KIT 9+1 COMPLETO DI-COMPLETE WITH

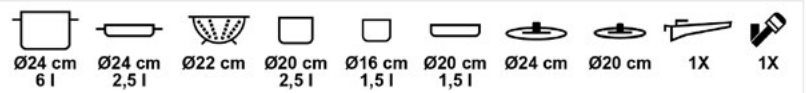

LAVELLI PORTATILI | PORTABLE SINKS

Lavello pieghevole

Lavello pieghevole realizzato in robusto materiale plastico con maniglie per il trasporto integrate e scolo chiudibile mediante tappo. Molto compatto da riporre e facile da trasportare grazie allo speciale sistema Fold-Away.

Tanq fold-away

Foldable wash bowl made of sturdy plastic with integrated carrying handles and lockable floor drain. The practical Fold-Away system allows compact folding and space saving storage.

| Articolo - Item | €/pc. | cm. | | kg. |
|-----------------|-------|---------------|-----------------|-------|
| | | (aperto-open) | (chiuso-closed) | |
| Z 08 30 020 | | 20Hx30,5Lx30P | 6Hx30,5Lx30P | 0,500 |

1 KIT **NEW**



Lavello pieghevole

Lavello pieghevole realizzato in robusto PVC con maniglie per il trasporto integrate e cinghie di contenimento. Molto compatto da riporre.

Tanq fold-away

Foldable wash bowl made of sturdy PVC with integrated carrying handles and belts. The practical Fold-Away system allows compact folding and space saving storage.

| Articolo - Item | €/pc. | cm. | | kg. |
|-----------------|-------|---------------|-----------------|-------|
| | | (aperto-open) | (chiuso-closed) | |
| Z 08 30 060 | | 28Hx53Lx27P | 2Hx53Lx27P | 0,500 |

1 made by **NEW**



SEALAND

29

CUCINA E LAVELLI | MELAMINE CROCKERY & SINKS



Piatto piano Dinner plate

| Articolo - Item | €/Box | Ø cm. | pcs. |
|-----------------|-------|-------|------|
| D 20 06 025 | | 25 | 6 |



MELAMINE WARE **NEW**



Piatto fondo Soup plate

| Articolo - Item | €/Box | Ø cm. | pcs. |
|-----------------|-------|-------|------|
| D 20 06 026 | | 21 | 6 |



MELAMINE WARE **NEW**



Piatto dessert Dessert plate

| Articolo - Item | €/Box | Ø cm. | pcs. |
|-----------------|-------|-------|------|
| D 20 06 027 | | 20 | 6 |



MELAMINE WARE **NEW**



Ciotola Bowl

| Articolo - Item | €/Box | Ø cm. | pcs. |
|-----------------|-------|-------|------|
| D 20 06 043 | | 15 | 3 |



MELAMINE WARE **NEW**



Insalatiera Salad bowl

| Articolo - Item | €/Box | Ø cm. | pcs. |
|-----------------|-------|-------|------|
| D 20 00 030 | | 23,5 | 1 |



MELAMINE WARE **NEW**



Vassoio Tray

| Articolo - Item | €/Box | cm. | pcs. |
|-----------------|-------|---------|------|
| D 20 00 081 | | 29,5x40 | 1 |



MELAMINE WARE **NEW**



Bicchieri di vino Wine glass

| | | |
|-----------------|-------|------|
| Articolo - Item | €/Box | pcs. |
| D 20 02 171 | | 2 |

POLYCARBONATE NEW



Bicchieri Prosecco Prosecco glass

| | | |
|-----------------|-------|------|
| Articolo - Item | €/Box | pcs. |
| D 20 02 205 | | 2 |

POLYCARBONATE NEW



Bicchieri acqua Water glass

| | | |
|-----------------|-------|------|
| Articolo - Item | €/Box | pcs. |
| D 20 03 185 | | 3 |

SAN HQ NEW



Bicchieri birra Beer glass

| | | |
|-----------------|-------|------|
| Articolo - Item | €/Box | pcs. |
| D 20 02 210 | | 2 |

POLYCARBONATE NEW



Tazza hot mug Hot mug

Realizzato in 100% Resylin. Impugnabile fino a una temperatura massima di 90°C.

Manufactured in 100% ABS Resylin. Can be hold up to max 90°C.

| | | | |
|-----------------|-------|-------------------|------|
| Articolo - Item | €/Box | Capacità-Capacity | pcs. |
| D 20 04 051 | | 30 cl. | 4 |



90° NEW



Tazzina Espresso Espresso

| | | |
|-----------------|-------|------|
| Articolo - Item | €/Box | pcs. |
| D 20 02 055 | | 2 |

MELAMINE WARE NEW



Tagliere Cutting board

| | | | |
|-----------------|-------|-------|------|
| Articolo - Item | €/pc. | cm. | pcs. |
| D 20 00 056 | | 36x24 | 1 |

MELAMINE WARE NEW



Portapanne Bread bin

| | | | |
|-----------------|-------|-------|------|
| Articolo - Item | €/pc. | cm. | pcs. |
| D 20 00 060 | | 24x24 | 1 |

MELAMINE WARE NEW



Aperitivo Aperitive

| | | |
|-----------------|-------|-----|
| Articolo - Item | €/Kit | Kit |
| D 20 00 042 | | 1 |

MELAMINE WARE NEW



Posacenere Ashtray

| | | |
|-----------------|-------|------|
| Articolo - Item | €/pc. | pcs. |
| D 20 00 071 | | 1 |

NEW



Posate insalata Salad silverware

| | | | |
|-----------------|-------|----------|-----|
| Articolo - Item | €/Box | Set pcs. | Set |
| D 20 00 039 | | 2 | 1 |

NEW



Posate Silverware

| | | | |
|-----------------|-------|----------|-----|
| Articolo - Item | €/Box | Set pcs. | Set |
| D 20 16 015 | | 16 | 1 |

SOFT TOUCH AISI 316 NEW



SEALAND

Serie vasellame «Sealand» Anti-slip

Serie di stoviglie realizzate in materiali plastici ad uso alimentare.

Caratteristiche:

- 1) fondo anti-slip che - mediante l'utilizzo di una guarnizione in gomma integrata nel fondo delle stoviglie - garantisce stabilità e riduce fortemente le cadute e le possibilità di spostamento;
- 2) resistenza al calore, al freddo e all'umidità, che le rende lavabili in lavastoviglie e utilizzabili in congelatore;
- 3) ottima resistenza agli urti e facilità di pulizia.

Le stoviglie sono realizzate in Melamina alimentare di alta qualità; le tazze in reslyn, un materiale termoplastico 100% BPA free caratterizzato da ottime proprietà isolanti e utilizzabile fino a 95°C; i bicchieri in SAN trasparente di elevata brillantezza.

Anti-slip «Sealand» kitchenware

Plastic kitchenware.

Features:

- 1) Anti-slip integrated bottom to ensure stability and dramatically reduce falls and moves.
- 2) Heat-, cold- and humidity-resistant, dishwasher- and freezer-safe.
- 3) Optimum impact resistance and easy to clean.

The kitchenware is made of high-quality food melamine; cups are made of reslyn, a 100% BPA-free thermoplastic material with excellent insulating properties and standing temperatures up to 95°; glasses are made of very bright clear SAN.

| Articolo - Item | €/Box | Descrizione-Description |
|-----------------|-------|---|
| D 20 30 000 | | Box composto da: 6 piatti piani / fondi / dessert, 6 bicchieri 30 cl, 6 tazze Box with: 6 plates / soup plates / dessert plates. 6 30-cl glasses, 6 cups |



CUCINA E LAVELLI | MELAMINE CROCKERY & SINKS

VISITA IL NOSTRO NUOVO WEBSITE



WWW.TREM.NET



RIPARAZIONE VELE | SAILS REPAIR

Kit di riparazione vele

Il kit è composto da:
 - 1 Bobina di filo poliestere 50 mt. Ø 1 mm.
 - 5 Aghi inglesi
 - 1 Rotolo di dacron autoadesivo
 - 1 Guardapalmo
 Il tutto in un pratico barattolo in plastica
 Ø 100 x H 55 mm.

Articolo - Item €/Kit

E 03 10 055



Sail repair set

Kit complete with:
 - 1 PE wire reel 50 mt. Ø 1 mm.
 - 5 English needles
 - 1 Adhesive Dacron reel
 - 1 Sewing palm
 Set supplied in a practical plastic box
 Ø 100 x H 55 mm.

COMPLETE WITH



Aghi per vele

Serie di 5 aghi per vele di varie foggie.

Articolo - Item €/Kit

E 03 00 050



Sailmakers needles

Kit with 5 needles for sails repair.



Aghi per vele originali inglesi

Serie di 5 aghi per tutti i tipi di vele.

Articolo - Item €/Kit

E 03 00 012



English sailmakers needles

Kit with 5 needles for all types of sails.



Guardapalmo

Fabbricato in cuoio con rinforzo metallico.
 Adatto per cucire o impiombare.

Articolo - Item €/pc.

F 24 00 100



Sewing palm

Manufactured in leather with metal reinforcement. Suitable for sewing or splicing.

Mod.

Destro-Right hand



COPRIDRAGLIE | STAY COVERS

Copridraglia rivestito

Fabbricato in poliuretano espanso morbido a cellule chiuse rivestite in tessuto di poliestere "cordura". Si applica alle draglie senza necessità di smontarle e si conforma perfettamente alle stesse senza antiestetici giochi. Adatto per draglie di qualsiasi diametro. Perfetto anche per coprire il tenditore.

Stay cover

Manufactured in closed cell polyurethane foam covered with "cordura" polyester fabric. Very smart system that fits to the stays avoiding disassembling. Perfect fit without clearance. Universal size for stays of any diameter. Also suitable to cover the turnbuckle.

| Articolo - Item | €/pc. | Lunghezza Length cm. | Ø esterno Outer Ø mm. | Colore Colour |
|-----------------|-------|-------------------------|--------------------------|------------------|
| B 16 00 100 | | 100 | 40 | Bianco-White |
| B 16 00 150 | | 150 | 40 | Bianco-White |
| B 16 75 100 | | 100 | 40 | Blu-Blue |
| B 16 75 150 | | 150 | 40 | Blu-Blue |



STECHE PER VELE | BATTENS FOR SAILS

Stecca per vele e tendalini

Per vele in fiberglass satinato. Garantiscono un'elevata resistenza e una notevole flessibilità. Progettate secondo le tecniche più innovative per andare incontro alle esigenze di regata.

| Articolo - Item | €/mt. | €/pc. | Piatto Plate mm. | Barre Bar mt. | Carico flessione orizz. Horiz. bending load | Suggested Terminals |
|-----------------|-------|-------|------------------|---------------|---|---------------------|
| M 24 18 002 | | | 18x2 | 2 | 320 | M2400008 |
| M 24 24 025 | | | 24x2,5 | 2 | 600 | M2400009 |
| M 24 15 003 | | | 15x3 | 2 | 420 | M2400005 |
| M 24 31 003 | | | 30x3 | 2 | 1155 | M2400010 |
| M 24 40 004 | | | 40x4 | 2 | 2080 | M2400016 |

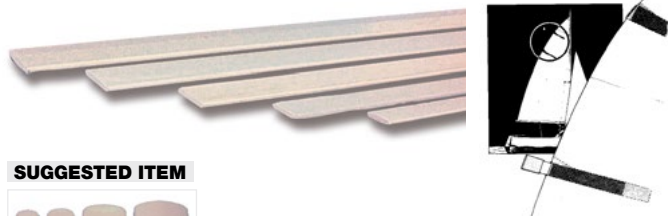

SUGGESTED ITEM



TERMINALI-TERMINALS
(pag. 572)

Battens for sails and boat awnings

Suited for satin fibreglass sails; high resistant and remarkable flexibility; designed according to the latest technologies and based on regatta demands.

Terminali per stecche

Fabbricati in materiale plastico di colore bianco.

Terminal caps for sails battens

Manufactured in white colour plastic material.

| Articolo - Item | €/Pair | €/Box | Adatti per stecche Suitable for battens | kg. |
|-----------------|--------|-------|---|-------|
| M 24 00 005 | | | M2415003 | 0,005 |
| M 24 00 008 | | | M2418002 | 0,008 |
| M 24 00 009 | | | M2424025 | 0,009 |
| M 24 00 010 | | | M2431003 | 0,010 |
| M 24 00 016 | | | M2440004 | 0,016 |



SUGGESTED ITEM



STECHE-BATTENS
(pag. 572)

PROTEZIONI PER VELE | SAILS PROTECTION

Serie proteggi arridatoi

Fabbricati in materia plastica molto morbida. Permette di potere coprire gli arridatoi sull'imbarcazione evitando di strappare i vestiti o le vele. Colore bianco.

Rigging screw covers

Made of soft plastic moulding. It prevents chafing of sheets and sails. White colour.

| Articolo - Item | €/pair | Lunghezza Length mm. | Per arridatoi For tender Ø mm. |
|-----------------|--------|----------------------|--------------------------------|
| M 27 08 380 | | 380 | 6-7 |
| M 27 12 420 | | 420 | 8-10 |
| M 27 14 500 | | 500 | 12-14 |



Copricrocette

Fabbricate in termoplastico morbido, progettate per le crocette sia a sezione tonda che alare. Si montano in pochi secondi.

Spreader boots

Manufactured in soft thermoplastic, designed for round- and wing-section cross-tees. Fast mounting.

| Articolo - Item | €/pc. | Per cavi fino a | Per crocetta sezione max |
|-----------------|-------|----------------------|--------------------------------|
| | | For cables up to mm. | For cross-tees max section mm. |
| L 43 06 000 | | 6 | Ø 29 |
| L 43 09 000 | | 9 | Ø 32 |
| L 43 13 000 | | 15 | Ø 55 |



«Sailguard» rotelle di protezione per le vele

In nylon bianco, si installano in pochi secondi senza staccare le sartie.

«Sailguard» sail savers

Manufactured in white nylon; easily installed without dismantling the shrouds.

| Articolo - Item | €/Box 2 kit | Ø mm. | Adatte per Suitable for |
|-----------------|-------------|-------|---------------------------------|
| L 43 60 000 | | 70 | Sartie fino a- Stays up to 7 mm |



KIT

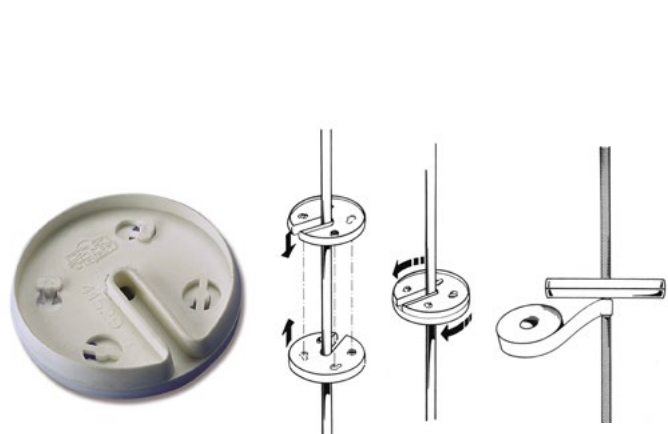

GRADINI PER ALBERO | STEPS FOR MAST

Gradino per albero

Realizzato in acciaio inox Aisi 316. Ideale per risalire l'albero senza bansigo, in assoluta sicurezza. Adatto per qualsiasi tipo di alberatura. Si consiglia un interasse di 60 cm. tra i gradini.

Step for mast

Manufactured in Aisi 316 stainless steel. Suitable for mast climbing without a bosun's chair, total safety. Universal size to fit any type of mast. Recommended to set a centre-to-centre space of 60 cm. between the steps.

| Articolo - Item | €/pc. | Tondo-Round Ø mm. | mm. |
|-----------------|-------|-------------------|-------------|
| S 20 00 080 | | 6 | 175x215x215 |



Garrocci per fiocco

Fabbricati in nylon, muniti di viti in ottone.

Hanks for jib

First quality nylon with brass fastening screws.

| Articolo - Item | €/pc. | €/Box | Ø mm. | kg. |
|-----------------|-------|-------|-------|-------|
| M 15 06 000 | | | 5 | 0,035 |
| M 15 07 000 | | | 6 | 0,040 |
| M 15 08 000 | | | 7 | 0,045 |



Passascotta in nylon nero

Black nylon sheet fairlead

| Articolo - Item | €/pc. | €/Box | Foro-Hole Ø mm. |
|-----------------|-------|-------|-----------------|
| N 33 10 000 | | | 9 |
| N 33 13 000 | | | 13 |
| N 33 16 000 | | | 17 |



Strozzacima in nylon

Ideale per fissare parabordi o ancore leggere.

Nylon rope grid cleat

Suitable to fasten fenders or light anchors.

| Articolo - Item | €/Blister | Lunghezza-Length mm. | kg. |
|-----------------|-----------|----------------------|-------|
| M 15 13 058 | | 90 | 0,100 |



PAIO
PAIR



Bozzelli a una puleggia

Fabbricati in nylon e acciaio inox.

Single blocks

Manufactured in nylon and stainless steel.

| Articolo - Item | €/pc. | Cima-Rope Ø mm. | Carico max Max load kg. | kg. |
|-----------------|-------|-----------------|-------------------------|-------|
| N 45 08 045 | | 8 | 150 | 0,030 |
| N 45 10 090 | | 10 | 300 | 0,070 |
| N 45 14 180 | | 12-14 | 600 | 0,100 |

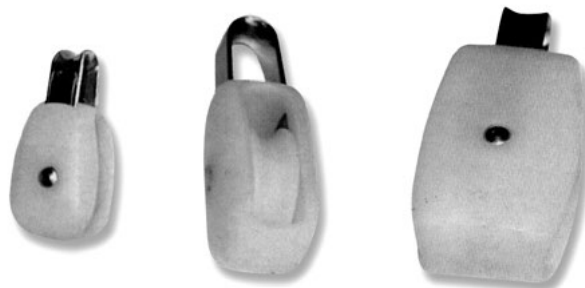

Carrello con ponticello

Traveller with bridge

| Articolo - Item | €/pc. | Lunghezza Length mm. | Larghezza Width mm. | Carico max Max load kg. | Per scafi fino a For boats up to mt. |
|-----------------|-------|----------------------|---------------------|-------------------------|--------------------------------------|
| N 56 62 247 | | 86 | 60 | 270 | 8 |



Bitta con morsetto da pulpito o battagliola

Bitta in nylon completa di morsetti per l'applicazione su pulpiti e battagliole.

Cleat with clips for guardrail

Nylon cleats with clips to be fixed on pulpits and guardrails.

| Articolo - Item | €/pc. | Bitta-Cleat mm. | Per tubo-For pipe Ø mm. |
|-----------------|-------|-----------------|-------------------------|
| N 32 22 110 | | 110 | 22-25 |

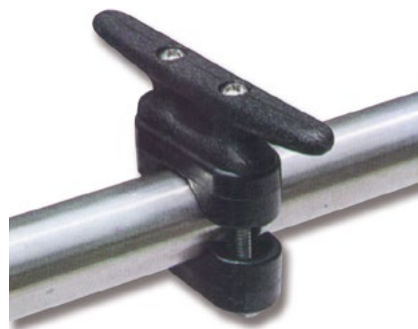

STICK | TILLER EXTENSIONS

Stick telescopico

Fabbricato in alluminio anodizzato con giunto terminale snodato. Impugnatura a pomolo terminale.

Telescopic tiller extension

Manufactured in anodized aluminium, with golf club handgrip.

| Articolo - Item | €/pc. | Giunto Joint | Tubi Pipes Ø mm. | Impugnatura Handle Ø mm. | Lunghezza Length cm. | Art. Giunto Joint Art. |
|-----------------|-------|--------------|------------------|--------------------------|----------------------|------------------------|
| N 41 00 140 | | Elastomer | 16,5-20 | 60 | 75-125 | N4141639 |
| N 41 20 075 | | Inox-S.S. | 16,5-20 | 60 | 75-125 | N4013000 |



COMPLETE WITH

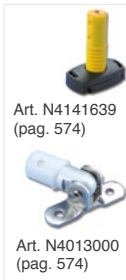

Prolunga barra timone

Fabbricata in alluminio anodizzato nero, con snodo in elastomero, impugnatura "golf".

Tiller extension

Manufactured in black anodized aluminium, with elastomer swivel and golf club handgrip.

| Articolo - Item | €/pc. | Ø mm. | Ø interno tubo Inner pipe Ø mm. | Lunghezza Length cm. |
|-----------------|-------|-------|---------------------------------|----------------------|
| N 40 20 060 | | 20 | 16,5 | 60 |



COMPLETE WITH



Art. N4141639 (pag. 574)

Stick fisso

Fabbricato in alluminio con impugnatura a pomolo terminale. Giunto flessibile inox. Ideale per derive o piccoli cabinati.

Steady tiller extension

Manufactured in aluminium, with golf club handgrip. Stainless steel flexible fitting. Suitable for sailing dinghies or small cabin cruisers.

| Articolo - Item | €/pc. | Lunghezza-Length cm. |
|-----------------|-------|----------------------|
| N 40 16 060 | | 60 |



COMPLETE WITH



Stick telescopico con impugnatura anatomica

Stick robusto ed estensibile con precisione. Regolabile nella sua lunghezza in modo semplice e preciso. Provvisto di impugnatura anatomica.

Telescopic tiller extension with anatomical handle

Sturdy tiller that extends with precision. Adjustable in length in an easy and precise way. Equipped with anatomical handle.

| Articolo - Item | €/pc. | Estensibile Extensible mm. | Tubo Pipe Ø mm. |
|-----------------|-------|----------------------------|-----------------|
| N 41 35 075 | | 700-1200 | 20x35 |



COMPLETE WITH



Snodo per stick inox

Stainless steel tiller extension fitting

| Articolo - Item | €/pc. | €/Box | Basetta-Base mm. | Per Tubo Ø interno For pipe inner Ø mm. |
|-----------------|-------|-------|------------------|---|
| N 40 13 000 | | | 14x54 | 18 |

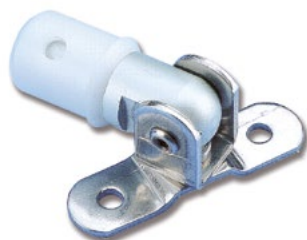

Giunto flessibile per stick

Fabbricato in nylon e neoprene, consente di disconnettere lo stick quando necessario.

Flexible tiller extension fitting

Manufactured in nylon and neoprene, allows easy removal of the tiller extension if necessary.

| Articolo - Item | €/pc. | Per Tubo Ø interno For pipe inner Ø mm. |
|-----------------|-------|---|
| N 41 41 639 | | 16,5 |



Segnavento «Mistral»

Segnavento con frecce, montato su pietra dura per la scorrevolezza. Molto sensibile e stabile, munito d'indicatore angolo bolina. Provvisto di chiave 8/13 per il montaggio. Venduto in una elegante confezione.

«Mistral» wind indicator

Wind indicator fitted with vanes, mounted on a hard stone suspension for sliding movement. Very accurate and stable, fitted with a wind angle indicator. Provided with 8/13 mounting wrench. Supplied in an elegant package.

| Articolo - Item | €/pc. | Mod. | Freccia-Vane mm. | H mm. |
|-----------------|-------|--|------------------|-------|
| N 20 00 090 | | Per cabinati fino a For cruisers up to 15 mt. | 380 | 320 |



Astine segnavento «Levante»

Si applicano al fianco dell'albero, con staffa a baionetta. Bilanciate con contrappeso, segnano il minimo vento. Fiamma intelaiata per evitare le false indicazioni.

«Levante» wind indicators

To be mounted on the side of the mast with a bayonet bracket. Counter-weight balance, it indicates minimal wind. Framed flag to avoid inaccurate indications.

| Articolo - Item | €/pc. | Materiale Material | Lunghezza sopravento Windward length mm. |
|-----------------|-------|----------------------------------|---|
| N 20 12 010 | | Acciaio inox con fiamma in nylon | 120x100 |
| N 20 13 013 | | Stainless steel with nylon flag | 130x130 |



Nastrini segnavento da sartie

Fabbricati in nylon con chiusura a velcro. Coppia rosso verde. Confezionati su cartoni espositivi.

Wind indicator strips

Manufactured in nylon with Velcro fastener. Red/green pairs. Packed in cardboard displays.

| Articolo - Item | €/Pair | Cavo-Cable Ø mm. | Paia-Pairs |
|-----------------|--------|---------------------|-----------------------------|
| N 20 03 010 | | 3 | 1 rosso/red + 1 verde/green |
| N 20 05 012 | | 5 | 1 rosso/red + 1 verde/green |
| N 20 08 016 | | 8 | 1 rosso/red + 1 verde/green |

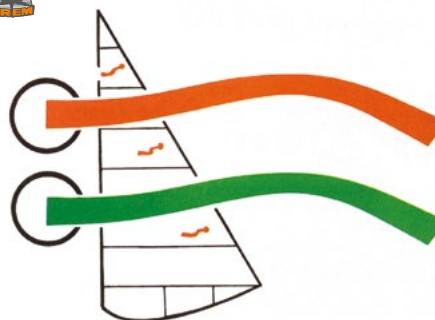

Fili segnavento PSP Tell Tales per regolazione vele

Fili segnavento permanenti. Contenuto confezione:
- 16 dischi autoadesivi
- 8 fili rossi, 8 fili blu
- 16 fili autoadesivi

PSP Tell Tales wind indicator strips for sail trimming

Permanent wind indicator strips. Package content:
- 16 self-adhesive discs
- 8 red strips, 8 blue strips
- 16 self-adhesive strips

| Articolo - Item | €/Kit |
|-----------------|-------|
| N 20 08 000 | |



Bandierina a manica a vento

Telaio fabbricato interamente in acciaio inox 18/8. Bandiera in tessuto di nylon. Fissaggio mediante attacco in acciaio inox, completa di viti.

Wind sock

Manufactured in stainless steel 18/8. Flag made of nylon fabric. Provided with stainless steel screws and fastening to the mast.

| Articolo - Item | €/pc. | mm. | kg. |
|-----------------|-------|--------|-------|
| N 20 06 025 | | 80x260 | 0,050 |



Segnavento a manica «America»

Bandiera in tessuto di nylon.

«America» wind indicator

Flag made of nylon fabric.

| Articolo - Item | €/pc. | Lunghezza-Length cm. | kg. |
|-----------------|-------|----------------------|-------|
| N 20 11 020 | | 100 | 0,050 |



Bandierina segnavento «Monzone»

Montata su astina. Fissaggio all'albero mediante attacco inox. Fabbricata in lega leggera anodizzata.

«Monzone» wind indicator

Light alloy pole. Vane of light weight plastic, extremely sensible on cardboard for rack.

| Articolo - Item | €/pc. | mm. | kg. |
|-----------------|-------|--------|-------|
| N 20 00 050 | | 150x90 | 0,060 |



INCLINOMETRI | INCLINOMETERS

Inclinometro

Inclinometro a bolla nera, realizzato interamente in plastica. Scala graduata 45°-0°-45°. Strumento molto stabile.

| Articolo - Item | €/pc. | ↑ mm. | ↓ kg. |
|-----------------|-------|-------|-------|
| N 20 90 042 | | 90x42 | 0,030 |



Inclinometer

Fully manufactured in plastic. 45°-0°-45° degree graduation. Strumento molto stabile.

Inclinometro

Inclinometro di alta precisione, grazie alla doppia bolla. Fissaggio con 4 viti o con autoadesivo in dotazione.

| Articolo - Item | €/pc. | Scale-Scales | ↑ mm. |
|-----------------|-------|------------------------------|--------|
| N 20 70 086 | | 30°- 0° - 30° - 5° - 0° - 5° | 100x80 |



PALLINE SEGNALAZIONE CIME | PLASTIC BALLS FOR ROPE

Serie 4 palline colorate per distinguere le cime a bordo

| Articolo - Item | €/Set 4 pcs. | Foro-Hole Ø mm. | Ø esterno outer Ø mm. |
|-----------------|--------------|-----------------|-----------------------|
| A 22 06 020 | | 5,5 | 30 |



Series of 4 colored balls to distinguish the ropes on board

MANIGLIE WINCH | WINCH HANDLES

Maniglia galleggiante per winch

Provvista di blocco "Lock In" sul winch. Universale su qualsiasi winch. Impugnatura montata su sfere. Fabbricata in nylon (fibra di vetro), garantisce la stessa robustezza delle maniglie in metallo.

Winch floating handle

Fitted with "Lock In" winch system. Universal size for any winch. Handle on ball bearings. Made of nylon (fiberglass), ensures the same strength as steel handles.

| Articolo - Item | €/pc. | Lunghezza-Length mm. |
|-----------------|-------|----------------------|
| M 25 00 020 | | 200 (8") |
| M 25 00 025 | | 250 (10") |



Maniglia di ricambio per winch

Fabbricata in alluminio anodizzato, con impugnatura in nylon e fermo di sicurezza. Modello universale.

| Articolo - Item | €/pc. | Lunghezza-Length mm. |
|-----------------|-------|----------------------|
| M 25 63 526 | | 290 |



Spare winch handle

Manufactured in anodized aluminium, with nylon handgrip and safety locking system. Universal model.

Maniglia winch universale

Fabbricata in alluminio anodizzato, con impugnatura su sfere.

| Articolo - Item | €/pc. | Lunghezza-Length mm. |
|-----------------|-------|----------------------|
| M 25 63 525 | | 250 |



Universal winch handle

Manufactured in anodized aluminium with ball grip.

BOE DA REGATA | REGATTA MARK BUOYS

Boe segnalazione regata

Fabbricate in Pvc gonfiabile, adatte per segnalare i luoghi di virata sui campi da regata.

Regatta mark buoys

Manufactured in inflatable Pvc. Suitable for signaling places of tack on racing courses.

| Articolo - Item | €/pc. | Ø mm. | H mm. | kg. |
|-----------------|-------|-------|-------|-------|
| P 11 80 120 | | 800 | 1200 | - |
| P 11 10 120 | | 1000 | 1200 | 4,750 |
| P 11 13 120 | | 1350 | 1200 | 7,400 |



30

RISERVE DI GALLEGGIAMENTO | FLOATING RESERVE

Riserva di galleggiamento «Optimist»

Colore bianco. Fabricata in PVC elettrosaldato gonfiabile.

Floating reserve «Optimist»

White colour. Manufactured in electrowelded PVC with hose for inflating.

| Articolo - Item | €/pc. | Lunghezza-Length cm. | Mod. |
|-----------------|-------|----------------------|--------------------------------------|
| N 01 40 100 | | 40x100 | Cono galleggiamento prua Bow cone |

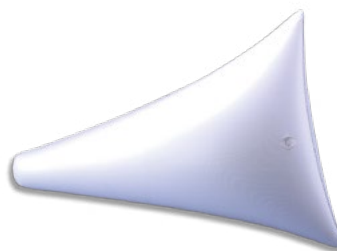

ACCESSORI VELA | SAILING ACCESSORIES

CORDE TRAINO SCI | WATER-SKI TOW ROPES

Corda traino sci da competizione

Fabbricata in levilene galleggiante giallo, con maniglia in alluminio ricoperta di morbido espanso nero, cappucci rastremati "Usa" e galleggiante nero.

| Articolo - Item | €/pc. | Ø mm. | Lunghezza-Length mt. |
|-----------------|-------|-------|----------------------|
| X 00 25 650 | | 7,5 | 21,7 |



Racing tow rope

Manufactured in bicolour yellow floating levilene, with aluminium handle coated with soft foam, genuine US streamlined terminals and black float.



Corda traino sci da competizione

In levilene galleggiante bicolore, con maniglie in morbido espanso nero, e interno in alluminio; galleggiante di colore arancio.

| Articolo - Item | €/pc. | Ø mm. | Lunghezza-Length mt. |
|-----------------|-------|-------|----------------------|
| X 00 00 600 | | 7,5 | 21,7 |



Racing tow rope

Manufactured in bicolour floating levilene, fitted with soft black foam handle, aluminium interior and orange float.



Corda traino sci regolamentare

Con maniglia in alluminio ricoperta di morbido espanso nero. Tipo regolamentare secondo D.M. 18/9/86.

| Articolo - Item | €/pc. | Carico di rottura Breaking load kg. | Lunghezza Length mt. |
|-----------------|-------|--|-------------------------|
| X 00 00 700 | | > 500 | 21,7 |



Approved tow rope

With aluminium handle coated with soft black foam. Approved for pleasure boating (Ministerial Decree 18/9/86).



Corda traino per gonfiabili ad alta resistenza

Per gonfiabili tipo Art. B8329722. Con cima galleggiante da 23 mt. Ø 8 mm. a 16 capi.

| Articolo - Item | €/pc. | Carico di rottura Breaking load kg. | Lunghezza Length mt. |
|-----------------|-------|--|-------------------------|
| X 00 13 092 | | 723 | 23 |



Tow ropes for high resistant inflatables

For inflatables Art. B8329722. Equipped with floating rope 23 mt. Ø 8 mm. 16 terminals.



SUGGESTED ITEM



Art. B8329722
(pag. 578)

GONFIABILI DA TRAINO | TRAILING INFLATABLES



«Funtube»

Fabbricato in PVC elettrosaldato con nylon in cordura e protezione in neoprene. Provvisto di valvola per gonfiaggio/sgonfiaggio rapido. Tubone con 2 maniglie di presa.

| Articolo - Item | €/pc. | Ø esterno Outer Ø cm. | Portata max Max load kg. |
|-----------------|-------|--------------------------|-----------------------------|
| B 83 29 722 | | 137 | 77 |



«Funtube»

Manufactured in electro-welded PVC with cordura nylon and neoprene protection. Equipped with rapid inflation/deflation valve. Large tube with 2 handles.

SUGGESTED ITEM



Art. X0013092
(pag. 578)

Specchietto retrovisore per sci nautici

Carcassa in ABS cromato ad alta resistenza, parte riflettente in vetro bombato per una visione panoramica. Perfetta visibilità ed argentatura garantita nel tempo. Dotato di basetta per il fissaggio su cruscotto e di basetta per fissaggio su cornice del parabrezza. Completo di viti di fissaggio. Regolamentare.

Rear-view mirror for water-skiing

High-resistance chromed ABS housing, vaulted glass to provide a perfect view over time. With base for mounting onto the control-panel, and base suited for windshield mounting. Supplied with fastening screws. Approved model.

| Articolo - Item | €/pc. | mm. |
|-----------------|-------|--------|
| X 00 00 265 | | 200x95 |

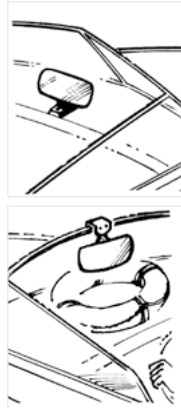

Asta per traino sci nautico

Fabbricata in acciaio inox lucidato a specchio con basi in acciaio inox. Conforme norme RINA.

Water-skiing towing pole

Manufactured in mirror polished stainless steel, with stainless steel base. Complying with RINA standards.

| Articolo - Item | €/pc. | Tubo-Pipe Ø mm. | Lunghezza-Length cm. |
|-----------------|-------|-----------------|----------------------|
| X 00 40 123 | | 40x2 | 120 |



Moschettone regolamentare per sci nautico

Fabbricato in acciaio inox Aisi 316. Si apre immediatamente anche sotto carico, da qualsiasi direzione si tiri la cimetta di sgancio. Vedi D.M. 4/2/60 e successivi.

Approved snap-hooks for water skiing

Manufactured in Aisi 316 stainless steel. It opens immediately from any direction even when loaded by simply pulling the release houseline.

| Articolo - Item | €/pc. | Ø mm. | A mm. | B mm. | C mm. | Carico lavoro Working load kg. | Carico max Max load kg. |
|-----------------|-------|-------|-------|-------|-------|--------------------------------|-------------------------|
| X 00 00 525 | | 15,8 | 59,5 | 37 | 16,7 | 175 | 700 |

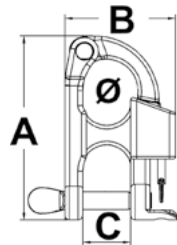

Triangoli sci «Torpedo»

Adatti per collegare la corda alle bitte di poppa. Galleggianti e muniti di corda e carrucola. Trazione max 200 kg.

Water ski triangles «Torpedo»

Suitable for fastening into to stern cleats. Floating, fitted with rope and pulley. 200 kg. max pull.

| Articolo - Item | €/pc. | Mod. | Corda-Rope cm. |
|-----------------|-------|-----------------|----------------|
| X 00 00 350 | | Semplice-Simple | 300 |



Triangolo sci a puleggia

Completo di cima con cappi per il fissaggio alle bitte di poppa e puleggia. Pratico ed economico.

Pulley water ski triangle

Complete with fastening ropes for stern cleat mounting and pulley. Practical and economical.

| Articolo - Item | €/pc. | Mod. | Corda-Rope cm. |
|-----------------|-------|--------------------------|----------------|
| X 00 00 210 | | Con puleggia-With pulley | 250 |



Anello traino sci nautico

Fabbricato in acciaio inox lucidato a specchio.

Water-ski tow ring

Manufactured in mirror polished stainless steel.

| Articolo - Item | €/pc. | Anello-Ring Ø mm. | Perni-Pins mm. |
|-----------------|-------|-------------------|----------------|
| X 00 53 592 | | 60 | 75x10 |



POLTRONCINE E SGABELLI | SEATS & STOOLS

Poltroncina pieghevole «Venus»

Colore Ecrù - Blu.

Modello pieghevole con maniglia per il trasporto.
Realizzata in tela acrilica.
Tubi in alluminio Ø 25 mm.

Folding seat «Venus»

Colours Ecrù - Blue.

Folding model with carrying handle.
Manufactured in acrylic fabric.
Aluminium pipes Ø 25 mm.

| Articolo - Item | €/pc. | A cm. | B cm. | C cm. | D cm. | Colore tessuto Fabric colour | kg. |
|-----------------|-------|-------|-------|-------|-------|---------------------------------|-------|
| D 17 45 050 | | 82 | 40 | 53 | 44 | Ecrù | 4,400 |
| D 17 45 075 | | 82 | 40 | 53 | 44 | Blu-Blue | 4,400 |



made by

VENUS

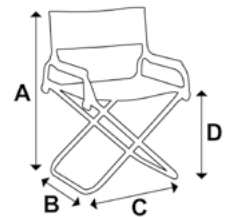

COMPLETE WITH

Art. D1745150 Ecrù
(pag. 583)Art. D1745175 Blue
(pag. 583)Art. D1725055
(pag. 583)

Sgabello pieghevole «Venus»

Colore Ecrù - Blu.

Realizzato in tela acrilica.
Tubi in alluminio Ø 25 mm.

Folding stool «Venus»

Colours Ecrù - Blue.

Manufactured in acrylic fabric.
Aluminium pipes Ø 25 mm.

| Articolo - Item | €/pc. | Altezza totale Total height cm. | Altezza seduta Seat height cm. | Larghezza Width cm. | Profondità Depth cm. | Colore tessuto Fabric colour | kg. |
|-----------------|-------|------------------------------------|-----------------------------------|------------------------|-------------------------|---------------------------------|-------|
| D 17 46 050 | | 52 | 44 | 50 | 40 | Ecrù | 4,000 |
| D 17 46 075 | | 52 | 44 | 50 | 40 | Blu-Blue | 4,000 |



made by

VENUS



COMPLETE WITH

Art. D1746150 Ecrù
(pag. 583)Art. D1746175 Blue
(pag. 583)Art. D1725055
(pag. 583)

Poltroncina pieghevole «Tebe»

Fabbricata in lega leggera anodizzata con snodi anticorrosione. Sedile e schienale in tela acrilica con doppia cucitura, imbottito. Semplificazione sostituzione della seduta. Riducibile di minimo ingombro.

Folding seat «Tebe»

Manufactured in light anodized alloy with anticorrosion joints. Seat and back made of acrylic. Easy replacement of seat. Minimal amount of space.

| Articolo - Item | €/pc. | A cm. | B cm. | C cm. | D cm. | Colore tessuto Fabric colour | kg. |
|-----------------|-------|-------|-------|-------|-------|---------------------------------|-------|
| D 17 91 152 | | 82 | 52 | 50 | 45 | Ecrù | 3,700 |
| D 17 75 152 | | 82 | 52 | 50 | 45 | Blu-Blue | 3,700 |

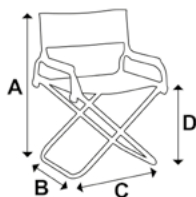

SUGGESTED ITEM

COMPLETE WITH

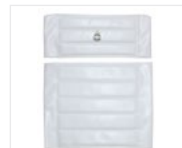

Art. D1747065 Sky/White (pag. 583)



Art. D1747165 Ecrù (pag. 583)



D1775165 Blue (pag. 583)



Art. D1725055 (pag. 583)

Poltroncina pieghevole profilo ovale

Fabbricata in lega leggera con snodi anticorrosione. Sedile e schienale in similpelle

Folding seat oval profile

Manufactured in light alloy with anticorrosion joints. Seat and back made of leather-imitation

| Articolo - Item | €/pc. | A cm. | B cm. | C cm. | D cm. | Colore telaio Frame colour | Colore tessuto Fabric colour |
|-----------------|-------|-------|-------|-------|-------|-------------------------------|---------------------------------|
| D 17 74 086 V | | 87 | 52 | 52 | 50 | Bianco-White | Bianco-White |
| D 17 74 086 G | | 87 | 52 | 52 | 50 | Grigio-Grey | Bianco-White |

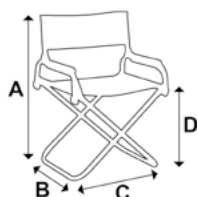

SUGGESTED ITEM

COMPLETE WITH



Art. D1775191 Blue (pag. 583)



Art. D1755191 White (pag. 583)

Sgabello pieghevole «Argo»

Fabbricato in lega leggera anodizzata con snodi anticorrosione. Tessuto acrilico.

Folding stool «Argo»

Manufactured in light anodized alloy with anticorrosion joints. Acrylic fabric.

| Articolo - Item | €/pc. | H seduta Seat H cm. | Larghezza Width cm. | Profondità Depth cm. | Colore tessuto Fabric colour | kg. |
|-----------------|-------|------------------------|------------------------|-------------------------|---------------------------------|-------|
| D 17 49 150 | | 44 | 46 | 41 | Ecrù | 2,800 |
| D 17 75 150 | | 44 | 46 | 41 | Blu-Blue | 2,800 |



COMPLETE WITH



Art. D1744163 Ecrù (pag. 583)



Art. D1775163 Blue (pag. 583)



Art. D1725055 (pag. 583)

Sedia pieghevole regista in alluminio anodizzato

Struttura in alluminio anodizzato Ø 25 mm. Seduta seduta in poliestere 600D.

Anodized aluminium director's folding chair

Anodized aluminium frame Ø 25 mm. Sturdy 600D polyester seat.

| Articolo - Item | €/pc. | Mod. | A cm. | B cm. | C cm. | D cm. | Colore tessuto Fabric colour |
|-----------------|-------|---------|-------|-------|-------|-------|------------------------------|
| D 17 75 158 | | Regista | 80 | 50 | 60 | 45 | ■ Blu-Blue |

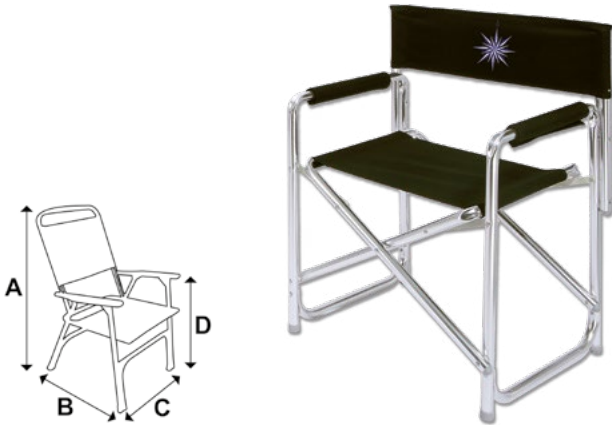

Sedia pieghevole in alluminio anodizzato

Struttura in alluminio anodizzato Ø 25 mm. Seduta in poliestere 600D. Viteria in acciaio inox, braccioli in legno verniciato ai poliuretani.

Anodized aluminium folding chair

Anodized aluminium frame Ø 25 mm. Sturdy 600D polyester seat. Stainless steel bolts and screws, polyurethane coated wooden armrests.

| Articolo - Item | €/pc. | A cm. | B cm. | C cm. | D cm. | Colore tessuto Fabric colour |
|-----------------|-------|-------|-------|-------|-------|------------------------------|
| D 17 75 192 | | 83 | 57 | 62 | 35 | ■ Blue Navy |

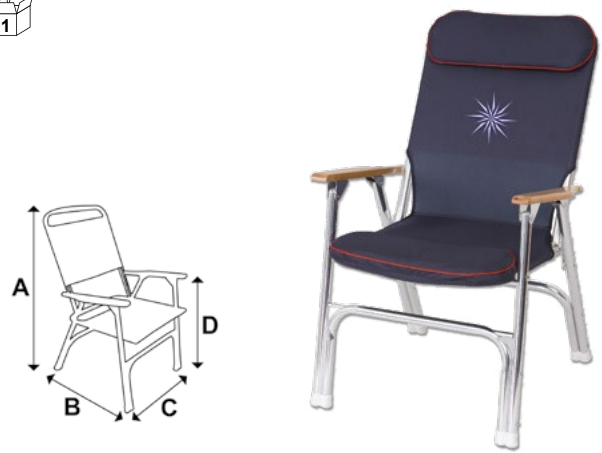

Sedia pieghevole imbottita in alluminio anodizzato

Struttura in alluminio anodizzato Ø 25 mm. Seduta imbottita in poliestere 600D. Viteria in acciaio inox, braccioli in legno verniciato.

Anodized aluminium folding padded chair

Anodized aluminium frame Ø 25 mm. Sturdy 600D polyester seat. Stainless steel bolts and screws. Painted wooden armrests.

| Articolo - Item | €/pc. | A cm. | B cm. | C cm. | D cm. | Colore tessuto Fabric colour |
|-----------------|-------|-------|-------|-------|-------|------------------------------|
| D 17 75 151 | | 90 | 45 | 60 | 35 | ■ Blue Navy |

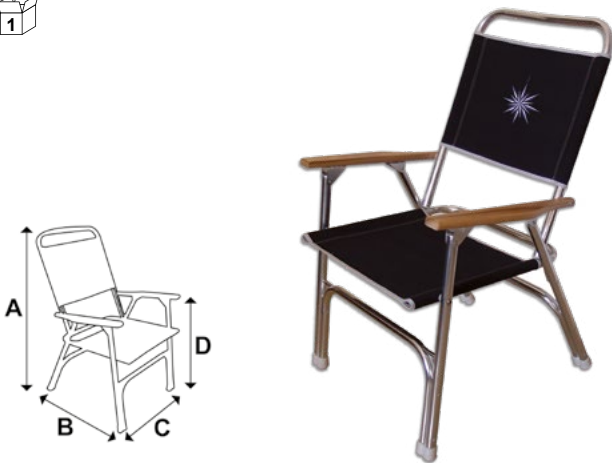

Poltroncina «Marina 1»

Pieghevole con braccioli abbattibili. Fabbricata in legno di faggio verniciato mogano. Sedile e schienale in tessuto blu mare con doppia cucitura, imbottito.

Chair «Marina 1»

Can be folded to be stored. Made of mahogany-painted beech wood. Stuffed seat and back made of cloth with double seam.

| Articolo - Item | €/pc. | A cm. | B cm. | C cm. | D cm. | Colore tessuto Fabric colour |
|-----------------|-------|-------|-------|-------|-------|------------------------------|
| D 18 01 075 | | 90 | 55 | 43 | 45 | ■ Blue Sea |
| D 18 01 078 | | 90 | 55 | 43 | 45 | ■ Ecrù |



Poltroncina «Marina 2»

Pieghevole. Fabbricata in legno di faggio verniciato mogano. Sedile e schienale in tessuto blu mare con doppia cucitura, imbottito.

Chair «Marina 1»

Can be folded to be stored. Made of mahogany-painted beech wood. Stuffed seat and back made of cloth with double seam.

| Articolo - Item | €/pc. | A cm. | B cm. | C cm. | D cm. | Colore tessuto Fabric colour |
|-----------------|-------|-------|-------|-------|-------|------------------------------|
| D 18 02 075 | | 90 | 55 | 50 | 45 | ■ Blue Sea |

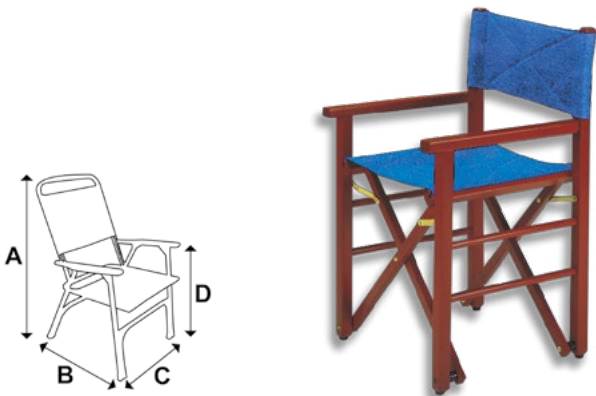

Seduta e schienale di ricambio per poltroncine

Fabbricati in tessuto vinilico.

Spare seat and back for folding seat

Manufactured in vinyl fabric.

| Articolo - Item | €/pc. | Colore-Colour | kg. |
|-----------------|-------|----------------|-------|
| D 17 55 191 | | □ Bianco-White | 0,350 |
| D 17 75 191 | | ■ Blu-Blue | 0,350 |



Seduta e schienale di ricambio per poltroncina «Tebe»

Fabbricati in tela acrilica.

Spare seat and back for seat «Tebe»

Manufactured in acrylic fabric.

| Articolo - Item | €/pc. | Colore-Colour | kg. |
|-----------------|-------|---------------|-------|
| D 17 47 165 | | ■ Ecrù | 0,230 |
| D 17 75 165 | | ■ Blu-Blue | 0,230 |



Seduta e schienale di ricambio per poltroncina «Venus»

Fabbricati in tela acrilica.

Spare seat and back for seat «Venus»

Manufactured in acrylic fabric.

| Articolo - Item | €/pc. | Kit composto da-Set complete with | Colore-Colour |
|-----------------|-------|--------------------------------------|---------------|
| D 17 45 150 | | 1 Schienale + 1 Seduta + 2 Braccioli | ■ Ecrù |
| D 17 45 175 | | 1 Back + 1 Seat + 2 Armrests | ■ Blu-Blue |



Seduta e braccioli di ricambio per sgabello «Venus»

Fabbricati in tela acrilica.

Spare seat and armrests for stool «Venus»

Manufactured in acrylic fabric.

| Articolo - Item | €/pc. | Kit composto da-Set complete with | Colore-Colour |
|-----------------|-------|-----------------------------------|---------------|
| D 17 46 150 | | 1 Seduta + 2 Braccioli | ■ Ecrù |
| D 17 46 175 | | 1 Seat + 2 Armrests | ■ Blu-Blue |



Seduta di ricambio per sgabello «Argo»

Fabbricata in tela acrilica.

Spare seat for stool «Argo»

Manufactured in acrylic fabric.

| Articolo - Item | €/pc. | Kit composto da-Set complete with | Colore-Colour |
|-----------------|-------|-----------------------------------|---------------|
| D 17 44 163 | | 1 Sedile di ricambio Argo | ■ Ecrù |
| D 17 75 163 | | 1 Spare seat Argo | ■ Blu-Blue |



Seduta e schienale di ricambio per poltroncina «Tebe»

Fabbricata in tela vinilica.

Spare seat and back for seat «Tebe»

Manufactured in vinyl fabric.

| Articolo - Item | €/pc. | Colore tessuto Fabric colour | kg. |
|-----------------|-------|------------------------------|-------|
| D 17 47 065 | | □ Bianco-White | 0,230 |



Kit 4 piedini di ricambio

Kit of 4 spare feet

| Articolo - Item | €/Kit 4 pcs. |
|-----------------|--------------|
| D 17 25 055 | |



KIT



Tavolo «Top Magnum Silver» con piano in carabottino

Fabbricato in alluminio brillantato, con piano in Teak e tappo in legno per regolare la stabilità. Modello con bordo ed angoli stondati. Completamente pieghevole per riporio.

Table «Top Magnum Silver» with wooden grating top

Base made of aluminium and wooden grating top. Wooden cap to adjust stability. With rounded edge and corners. Completely folding for storage.

| Articolo - Item | €/pc. | cm. | H cm. |
|-----------------|-------|--------|-------|
| D 17 72 140 | | 140x70 | 73 |

 **GAMBA IN ALU BRILLANTATO**
ALUMINIUM PEDESTALS



Tavolo lusso «Itaca» con piano in multistrato di teak

Regolabile in altezza in tre posizioni. Fabbricato in lega leggera anodizzata e snodi in anticorrosione. Piano in legno multistrato fenolico teak. Si chiude completamente per riporio.

Table extra «Itaca» in teak

Adjustable height in three different positions. Multilayer phenolic plywood Teak. Made of light anodized alloy with anticorrosion joints. Completely folding for storage.

| Articolo - Item | €/pc. | cm. | H cm. | kg. |
|-----------------|-------|--------|----------|--------|
| D 17 60 100 | | 115x60 | 75-65-50 | 10,000 |

 **GAMBA IN ALU BRILLANTATO**



Tavolo extra «Stylis» con piano in laminato bianco

Regolabile in altezza in tre posizioni. Fabbricato in lega leggera anodizzata o verniciata bianco e snodi in anticorrosione. Piano in legno multistrato fenolico laminato bianco.

Table extra «Stylis» with white laminated wooden plane

Adjustable height in three different positions. White laminated wooden plane. Made of light anodized alloy with anticorrosion joints. Multilayer white phenolic plywood Teak.

| Articolo - Item | €/pc. | cm. | H cm. | kg. |
|-----------------|-------|--------|----------|--------|
| D 17 60 098 | | 115x60 | 75-65-50 | 10,000 |

 **GAMBA IN ALU BRILLANTATO**



Tavolo pieghevole di alta qualità

High-quality folding table

Struttura tubo in alluminio anodizzato Ø 25 mm.
Ripiano in Verzalit bianco con decoro, spessore 16 mm.

Anodized aluminium frame Ø 25 mm.
White Verzalit table top with decoration, thickness 16 mm.

| Articolo - Item | €/pc. | Forma piano-Table top shape cm. | ↳ Piano-Table top cm. | H cm. | kg. |
|-----------------|-------|---------------------------------|-----------------------|-------|------|
| D 17 71 093 | | Rettangolare-Rectangular | 88x60 | 70 | 7,00 |
| D 17 71 113 | | Rettangolare-Rectangular | 110x60 | 70 | 7,50 |
| D 17 50 063 | | Quadrato-Square | 60x60 | 51 | 6,80 |



Tavolo con base tritelescopica

Table with adjustable support

Regolazione in tre posizioni. Piano con sede per bicchieri.

Adjustable in three positions. Equipped with glass holder on the top.

| Articolo - Item | €/pc. | Forma piano-Table top shape cm. | ↳ cm. | H cm. |
|-----------------|-------|---------------------------------|-------|----------|
| D 17 03 070 | | Ovale-Oval | 70x50 | 32-52-72 |



COMPLETE WITH



Art. D1776046
(pag. 586)

Art. O1432720
(pag. 586)

Tavolo con base smontabile

Table with removable support

Gamba in alluminio. Piano con sede per bicchieri.

Aluminium pedestal. Equipped with glass holder on the top.

| Articolo - Item | €/pc. | Forma piano-Table top shape cm. | ↳ cm. | H cm. |
|-----------------|-------|---------------------------------|-------|-------|
| D 17 01 070 | | Ovale-Oval | 70x50 | 70 |



COMPLETE WITH



Art. D1776046
(pag. 586)

Art. D1770079
(pag. 586)

Piani idrofughi per tavoli

In laminato bianco con decoro marino e finitura bordata.

Water resistant tops for table

Manufactured in white laminated wooden plane with marine decoration.

| Articolo - Item | €/pc. | Forma piano-Table top shape cm. | ↑ cm. |
|-----------------|-------|---------------------------------|--------|
| D 17 50 363 | | Quadrato-Square | 60x60 |
| D 17 60 393 | | Rettangolare-Rectangular | 90x60 |
| D 17 60 313 | | Rettangolare-Rectangular | 110x60 |

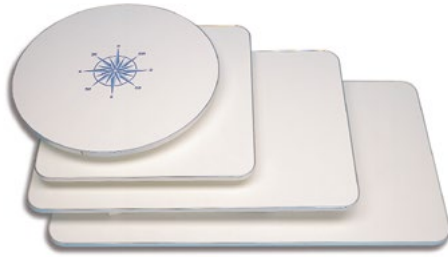

Tavolo in ABS bianco

Provvisto di alloggiamenti per tazze, bottiglie, bicchieri.

ABS white table

Provided with housings for cups, bottles, glasses.

| Articolo - Item | €/pc. | Forma piano-Table top shape cm. | Alloggiamenti Housings | Per basi For basis | ↑ cm. |
|-----------------|-------|---------------------------------|------------------------|----------------------------------|-------|
| D 17 76 046 | | Ovale-Oval | 2 | D1770079 D1770074 O1432720 | 77x51 |



madeby



Gamba tavolo tritelescopica in alluminio

Gamba manuale in alluminio anodizzato. Non è necessario forare il pavimento per effettuare la discesa. Base in composito.

Tri-telescopic aluminium table pedestal

Manually-operated anodized aluminium pedestal. It is not necessary to bore the floor for downstroke. Composite base.

| Articolo - Item | €/Kit | H mm. | Base Ø mm. | Tube-Tubes Ø mm. | Piastra tavolo Table plate Ø mm. |
|-----------------|-------|---------|------------|------------------|----------------------------------|
| O 14 32 720 | | 320-720 | 240 | 73/60/50 | 220 |



madeby



Gamba tavolo in alluminio anodizzato

Composta da due basi in alluminio (una esterna, una ad incasso) pressofuse e tubo in alluminio anodizzato D1760070. Si consiglia l'installazione all'interno.

Anodized aluminium table pedestal

Pedestal composed by two diecast aluminium bases (one external and one for flush mounting) and an anodized aluminium tube D1760070. Recommended for indoor installation only.

| Articolo - Item | €/Kit | H mm. | Tube-Tube Ø mm. | Base tavolo Table base Ø mm. | Base incasso pavimento Floor recess base Ø mm. | Base pavimento di ricambio Spare floor base | Base tavolo di ricambio Spare table base |
|-----------------|-------|-------|-----------------|------------------------------|--|---|--|
| D 17 70 079 | | 700 | 60 | 165 | 160 | D1700155 | D1700170 |



madeby



SUGGESTED ITEM



COMPLETE WITH



Gamba tavolo in alluminio verniciato

Verniciata bianca con resine epossidiche, composta da due basi in alluminio (una esterna, una ad incasso) pressofuse e tubo in alluminio verniciato D1774170.

Painted aluminium table pedestal

White epoxy coated finish. Pedestal composed by two aluminium bases (one external and one for flush mounting) and a painted aluminium tube D1774170.

| Articolo - Item | €/Kit | H mm. | Tube-Tube Ø mm. | Base tavolo Table base Ø mm. | Base incasso pavimento Floor recess base Ø mm. | Base pavimento di ricambio Spare floor base | Base tavolo di ricambio Spare table base |
|-----------------|-------|-------|-----------------|------------------------------|--|---|--|
| D 17 70 074 | | 700 | 60 | 165 | 160 | D1774155 | D1774170 |



madeby



SUGGESTED ITEM



COMPLETE WITH



Tubi conificati per gambe tavolo

Fabbricati in alluminio anodizzato.
Estremità conificate.

Conical tubes for table pedestals

Manufactured in anodized aluminium.
Conical edges.

| Articolo - Item | €/pc. | H mm. | Mod. | Colonna Pedestal Ø mm. | Finitura Finishing |
|-----------------|-------|-------|--------------|------------------------|---------------------------------|
| D 17 60 060 | | 600 | Fisso-Steady | 60 | Anodizzato-Anodized |
| D 17 60 070 | | 700 | Fisso-Steady | 60 | Anodizzato-Anodized |
| D 17 74 070 | | 700 | Fisso-Steady | 60 | Verniciato bianco-White painted |

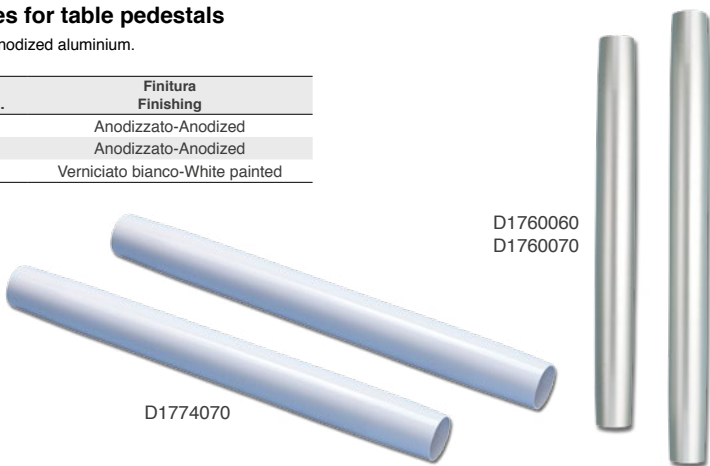

SUGGESTED ITEM



Basi di ricambio per gambe tavolo coniche

Spare bases for conical table pedestals

| Articolo - Item | €/pc. | Ø esterno Outer Ø mm. | Materiale Material | Per tubo For tube | Tubo-Tube Ø mm. |
|-----------------|-------|-----------------------|---|-------------------|-----------------|
| D 17 00 155 | | 160 | Alluminio-Alu | D1760060-D1760070 | 60 |
| D 17 00 170 | | 165 | Alluminio-Alu | D1760060-D1760070 | 60 |
| D 17 74 155 | | 160 | Alluminio verniciato bianco White painted alu | D1774070 | 60 |
| D 17 74 170 | | 165 | Alluminio verniciato bianco White painted alu | D1774070 | 60 |
| D 17 74 110 | | 110 | Alluminio verniciato bianco White painted alu | D1774070 | 60 |



SUGGESTED ITEM



Tappo

Fabbricato in plastica bianca. Adatto per sigillare il foro a pavimento delle basi tavolo.

Plug

Manufactured in white plastic. Suitable to cover the bores of table bases on the floor.

| Articolo - Item | €/pc. | Per basi-Suitable for base |
|-----------------|-------|--|
| D 17 60 030 | | D1774110-D1774155-D1700155-D1700170-D1774170 |



VISITA IL NOSTRO NUOVO WEBSITE



WWW.TREM.NET



CUSCINI | PILLOWS

Cuscino salvagente bianco con stampa nodi

Ricoperto di forte tela impermeabile con decorazioni marine. Interno in materiale espanso a cellule chiuse. Provvisto di maniglie per poterlo impiegare come salvagente in caso di soccorso.

| Articolo - Item | €/pc. | mm. | Galleggibilità-Buoyancy |
|-----------------|-------|-------------|-------------------------|
| B 16 37 010 | | 370x370x50 | 85N |
| B 16 74 010 | | 370x370x100 | 100N |

 made by 



B1637010

B1674010

Cuscino salvagente bianco con stampa codici navigazione

Ricoperto di forte tela impermeabile con decorazioni marine. Interno in materiale espanso a cellule chiuse. Provvisto di maniglie per poterlo impiegare come salvagente in caso di soccorso.

| Articolo - Item | €/pc. | mm. | Galleggibilità-Buoyancy |
|-----------------|-------|------------|-------------------------|
| B 43 37 010 | | 370x370x50 | 85N |

 made by 

**White floating pillow with knot printing**

Composed inside with closed cells foam. Covered outside with plastified cloth with nautical decors. With handles.

| Articolo - Item | €/pc. | mm. | Galleggibilità-Buoyancy |
|-----------------|-------|------------|-------------------------|
| B 43 37 010 | | 370x370x50 | 85N |

 made by 

Cuscino salvagente bianco con stampa rosa dei venti

Ricoperto di forte tela impermeabile con decorazioni marine. Interno in materiale espanso a cellule chiuse. Provvisto di maniglie per poterlo impiegare come salvagente in caso di soccorso.

| Articolo - Item | €/pc. | mm. | Galleggibilità-Buoyancy |
|-----------------|-------|------------|-------------------------|
| B 16 37 037 | | 370x370x50 | 85N |

 made by 

**White floating pillow with wind rose printing**

Composed inside with closed cells foam. Covered outside with plastified cloth with nautical decors. With handles.

| Articolo - Item | €/pc. | mm. | Galleggibilità-Buoyancy |
|-----------------|-------|------------|-------------------------|
| B 16 37 037 | | 370x370x50 | 85N |

 made by 

Cuscino salvagente per battagliole con stampa nodi

Ricoperto di forte tela impermeabile con decorazioni marine. Interno in materiale espanso a cellule chiuse. Provvisto di maniglie per poterlo impiegare come salvagente in caso di soccorso.

| Articolo - Item | €/pc. | mm. | Galleggibilità-Buoyancy |
|-----------------|-------|---------------|-------------------------|
| B 16 37 025 | | 370x370x25x25 | 85N |

 made by 

**Floating pillow for hand rail with knot printing**

Composed inside with closed cells foam. Covered outside with plastified cloth with nautical decors. With handles.

| Articolo - Item | €/pc. | mm. | Galleggibilità-Buoyancy |
|-----------------|-------|---------------|-------------------------|
| B 16 37 025 | | 370x370x25x25 | 85N |

 made by 

Cuscino salvagente blu con stampa nodi

Ricoperto di forte tela impermeabile con decorazioni marine. Interno in materiale espanso a cellule chiuse. Provvisto di maniglie per poterlo impiegare come salvagente in caso di soccorso.

| Articolo - Item | €/pc. | mm. | Galleggibilità-Buoyancy |
|-----------------|-------|------------|-------------------------|
| B 16 75 010 | | 370x370x50 | 85N |

 made by 

**Blue floating pillow with knot printing**

Composed inside with closed cells foam. Covered outside with plastified cloth with nautical decors. With handles.

| Articolo - Item | €/pc. | mm. | Galleggibilità-Buoyancy |
|-----------------|-------|------------|-------------------------|
| B 16 75 010 | | 370x370x50 | 85N |

 made by 

Cuscino salvagente blu con stampa rosa dei venti

Ricoperto di forte tela impermeabile con decorazioni marine. Interno in materiale espanso a cellule chiuse. Provvisto di maniglie per poterlo impiegare come salvagente in caso di soccorso.

| Articolo - Item | €/pc. | mm. | Galleggibilità-Buoyancy |
|-----------------|-------|------------|-------------------------|
| B 16 75 037 | | 370x370x50 | 85N |

 made by 

**Blue floating pillow with wind rose printing**

Composed inside with closed cells foam. Covered outside with plastified cloth with nautical decors. With handles.

| Articolo - Item | €/pc. | mm. | Galleggibilità-Buoyancy |
|-----------------|-------|------------|-------------------------|
| B 16 75 037 | | 370x370x50 | 85N |

 made by 

ROYAL COMFORT

CUSCINI | CUSHIONS

Cuscino e sedia autoreggente

Il cuscino può essere utilizzato su qualsiasi superficie senza il rischio che scivoli via. Realizzato in schiuma poliuretanicata rivestita contiene al suo interno una cerniera regolabile in 6 posizioni. In ciascuna posizione garantisce un ottimo supporto alla schiena senza sbilanciarsi.

Caratteristiche tecniche:

- Galleggiante in acqua
- Completo di maniglia per il trasporto
- Non ha parti ruvide o taglienti
- Resistente ai raggi UV

Stay-up pillow and chair

The pillow can be placed on any surface without sliding away. Manufactured in coated polyurethane foam, the inside hinge system enables to adjust the back in 6 different positions for full back support without unbalancing.

Technical specification:

- Floating if it falls overboard
- Complete with carrying handle
- No rough or sharp parts
- UV resistant

| Articolo - Item | €/pc. | mm. | Colore-Colour | Mod. |
|-----------------|-------|----------|---------------|---------|
| B 16 75 099 | | 100x49x8 | Blu-Blue | CLASSIC |



Cuscino singolo

Realizzato in cotone impermeabile riempito con silicone Kapock. Colore Blue Navy

| Articolo - Item | €/pc. | mm. |
|-----------------|-------|------------|
| B 16 75 040 | | 400x400x70 |



Single pillow

Manufactured in waterproof cotton filled with Kapock silicone. Blue Navy colour.



Cuscino con schienale

Realizzato in cotone impermeabile riempito con silicone Kapock. Colore Blue Navy

| Articolo - Item | €/pc. | mm. |
|-----------------|-------|------------------|
| B 16 75 083 | | 850x400x140 (70) |



Double pillow

Manufactured in waterproof cotton filled with Kapock silicone. Blue Navy colour.



Cuscino in cotone impermeabile «Rollo»

Riempito con silicone Kapock. Colore Blue Navy

| Articolo - Item | €/pc. | mm. |
|-----------------|-------|----------|
| B 16 19 044 | | Ø190x440 |



Waterproof cotton pillow «Rollo»

Filled with Kapock silicone. Blue Navy colour.

Cuscino in cotone impermeabile per battaglie

Riempito con silicone Kapock. Colore Blue Navy

| Articolo - Item | €/pc. | mm. |
|-----------------|-------|------------|
| B 16 20 038 | | 380x200x70 |



Waterproof cotton pillow for hand rail

Filled with Kapock silicone. Blue Navy colour.



ARTICOLI DA REGALO E OGGETTISTICA | GIFTS & GADGETS

Posacenere in acciaio inox

Modello molto stabile, grazie al fondo appesantito. Provvisto di disegni in stile nautico.

Stainless steel ashtray

Very stable, thanks to the heavy end. Marine style design.

| Articolo - Item | €/pc. | Colore-Colour | kg. |
|-----------------|-------|---------------|-------|
| D 12 06 226 | | Blu-Blue | 0,280 |
| D 12 82 226 | | Rosso-Red | 0,280 |

**Zerbino d'ingresso**

Realizzato in PVC di colore blu.

Door mat

Manufactured in blue PVC.

| Articolo - Item | €/pc. | cm. | kg. |
|-----------------|-------|-------|-------|
| B 51 12 031 | | 60x40 | 0,600 |

**Amaca portaoggetti****Stowage hammock**

| Articolo - Item | €/pc. | kg. |
|-----------------|-------|-------|
| Z 00 00 390 | | 0,390 |

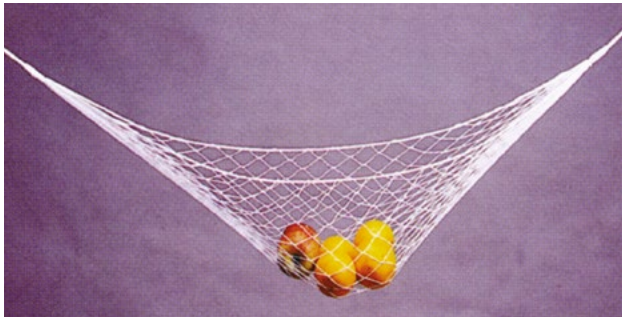
**Cinghietto salva occhiali**

Realizzato in poliestere di vari colori.

Mats

Manufactured in polyester of various colors.

| Articolo - Item | €/pc. | €/Box |
|-----------------|-------|-------|
| T 40 35 060 | | |

**Contenitore portamonete**

Colori assortiti.

Key-holder and pursecase

Assorted colours.

| Articolo - Item | €/pc. |
|-----------------|-------|
| B 40 30 120 | |



Coltello in acciaio inox per vela

Munito di lama, punteruolo, aprigrilli a scomparsa e cacciavite. Finitura accurata.

Stainless steel knife for sailing

Complete with blade, fid, folding shackle key and screw-driver. High quality finish.

| Articolo - Item | €/pc. | Colore impugnatura Handle colour | Lama Blade mm. | L chiuso Closed mm. | L aperto Open mm. |
|-----------------|-------|--|-------------------|------------------------|----------------------|
| D 14 00 160 | | Inox lucidato a specchio Mirror-polished SS | 65 | 100 | 150 |



Coltello in acciaio inox con impugnatura in plastica per vela

Con impugnatura in plastica colorata, completo di punteruolo e aprigrilli.

Stainless steel knife with plastic handle for sailing

With coloured plastic handle. Complete with fid and folding shackle key.

| Articolo - Item | €/pc. | Colore impugnatura Handle colour | Lama Blade mm. | L chiuso Closed mm. | L aperto Open mm. |
|-----------------|-------|-------------------------------------|-------------------|------------------------|----------------------|
| D 14 00 958 | | Giallo-Yellow | 65 | 100 | 155 |



Coltello in legno «Yacht»

Con caviglia e manico in legno.

Wooden knife «Yacht»

Wooden handle.

| Articolo - Item | €/pc. | Lama-Blade mm. |
|-----------------|-------|----------------|
| D 14 00 923 | | 75 |



Coltello in acciaio inox di alta qualità

Completo di aprigrilli, punteruolo per impiombature con blocco, cacciavite, apribottiglie, slamatore per ami.

Stainless steel high quality knife

Complete with shackle key, fid, bottle opener, screwdriver, hook disgorgor.

| Articolo - Item | €/pc. | Colore impugnatura Handle colour | Lama Blade mm. | L chiuso Closed mm. | L aperto Open mm. |
|-----------------|-------|--|-------------------|------------------------|----------------------|
| D 14 00 190 | | Acciaio lucidato a specchio Mirror-polished steel | 70 | 100 | 155 |



Coltello in acciaio inox con punteruolo e fodero

Completo di punteruolo con aprigrilli e fodero in cuoio con aggancio per cintura, pratico e robusto.

Stainless steel knife with fid in leather cover

Complete with fid and shackle key, very practical and sturdy leather cover with belt hook.

| Articolo - Item | €/pc. | Colore impugnatura Handle colour | Lama Blade mm. | L chiuso Closed mm. | L aperto Open mm. |
|-----------------|-------|-------------------------------------|-------------------|------------------------|----------------------|
| D 14 00 130 | | Plastica gialla Yellow plastic | 131 | 240 | 230 |



Coltello galleggiante «B92»

Colore arancio. Manico in espanso.

Floating knife «B92»

Orange colour. Foam handle.

| Articolo - Item | €/pc. | Colore impugnatura Handle colour | Lama Blade mm. | L totale Total mm. |
|-----------------|-------|-------------------------------------|-------------------|-----------------------|
| D 14 00 092 | | Arancio Orange | 65 | 165 |



PORTACHIAVI | KEY HOLDERS

Portachiavi galleggiante in sughero

Con cima e anello di ritegno in acciaio inox.

Cork floating key holder

Complete with strap and stainless steel keyring.

| Articolo - Item | €/pc. | Forma-Shape | Ø mm. |
|-----------------|-------|--------------|-------|
| D 31 00 022 | | Pallina-Ball | 50 |



Portachiavi galleggiante a forma di parabordo Majoni

Completo di grillo e catenella in ottone dorato, porta fino a cinque chiavi. Indicato come oggetto promozionale, possibilità di inserire il logo del cantiere, il numero della cabina da spiaggia, della camere di albergo, ecc.

Majoni Fender-shape floating key holder

Complete with shackle and golden brass chain, holds up to five keys. Suitable for marketing, printing the shipyard's logo, the number of cabin, hotel rooms, etc.

| Articolo - Item | €/pc. | mm. |
|-----------------|-------|-------|
| D 31 18 000 | | 80x30 |



D3100021



D3100020



D3100018

Portachiavi a ciondolo in ottone lucido Pendant polished brass key holder

| Articolo - Item | €/pc. | Forma-Shape |
|-----------------|-------|-----------------|
| D 31 00 021 | | Elica-Propeller |
| D 31 00 020 | | Ancora-Anchor |
| D 31 00 018 | | Fanale-Lamp |
| D 31 00 031 | | Bozzello-Block |
| D 10 00 014 | | Bussola-Compass |



D3100031



D3100014



Portachiavi galleggianti assortiti Assorted floating key holders

Disponibili in 2 modelli assortiti (elica-timone) con espositore.

Available in 2 assorted models (propeller-rudder) with display.

| Articolo - Item | €/Kit | pcs. |
|-----------------|-------|--|
| D 01 00 000 | | Kit composto da 50 portachiavi + espositore Kit with 50 key holders + display |



made by KIT



Portachiavi galleggiante in morbida gomma

Con catenella in ottone. Molto comodi e pratici, possono contenere due chiavi grosse o tre piccole. Possibilità di stampare il proprio logo.

Soft rubber floating key holder

Complete with brass chain. Convenient and practical, it can hold up to two large keys or three small ones. Logo customized printing.

| Articolo - Item | €/Box | Descrizione/Colore Description/Colour | Serigrafia Screen printing | pcs. |
|-----------------|-------|--|-------------------------------|------|
| D 32 74 000 | | <input type="checkbox"/> Bianco-White | Standard | 10 |
| D 32 75 000 | | <input type="checkbox"/> Blu-Blue | Standard | 10 |
| D 32 82 000 | | <input type="checkbox"/> Rosso-Red | Standard | 10 |
| D 32 77 000 | | <input type="checkbox"/> Giallo-Yellow | Standard | 10 |

 ORDINE MINIMO PERSONALIZZATO 100 PZ.
MOQ PRIVATE LABEL 100PC.



Portachiavi galleggiante da polso

Realizzato in morbida spugna galleggiante. Può contenere fino a quattro chiavi grosse e sei piccole.

Wrist floating key holder

Manufactured in soft floating sponge. It can hold up to four large keys or six small ones.

| Articolo - Item | €/pc. | Descrizione/Description | Lunghezza-Length mm. |
|-----------------|-------|--|----------------------|
| D 31 18 001 | | Rosso con sito TREM Red with TREM website | 200 |

 **NEW** made by 

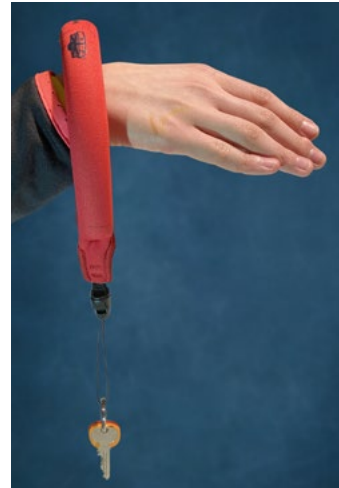

VISIT OUR B2B AREA

- CREATE A CUSTOMER ACCOUNT
- CHECK AVAILABILITY & QUANTITY OF ITEMS
- CHECK YOUR COMMERCIAL CONDITION
- PLACE YOUR ORDER
- TRACK YOUR ORDER STATUS
- TRACK YOUR PAYMENT PROCESS



WWW.TREM.NET



Bici pieghevole

Realizzata in acciaio verniciato.
Sella in poliuretano.
Provvista di ruote da 20".
Parafanghi in plastica.

Folding bicycle

Manufactured in painted steel.
Polyurethane saddle.
Provided with 20" wheels.
Plastic fenders.

| Articolo - Item | €/pc. | Mod. | Colore Colour | ↕ cm. | | kg. |
|-----------------|-------|-----------|------------------|----------------|------------------|--------|
| | | | | Aperta Open | Chiusa Closed | |
| O 00 20 006 | | Bici-Bike | Nero-Black | 73x30x43 | 140x55x95 | 13,000 |



made by



CAMBIO SHIMANO 6 MARCE
SHIMANO GEARS 6 SPEEDS

SUGGESTED ITEM



Art. O0080013
(pag. 594)

Prima di essere utilizzate, le bici acquistate devono essere da Voi registrate
Please register your bikes before first use

RUOTE-WHEELS 20"



Bici pieghevole con cambio

Realizzata in acciaio verniciato.
Sella in poliuretano.
Provvista di ruote da 16".
Cambio Shimano a 6 marce.

Folding bicycle with gears

Manufactured in painted steel.
Polyurethane saddle.
Provided with 16" wheels.
Shimano gears with 6 speeds.

| Articolo - Item | €/pc. | Mod. | Colore Colour | ↕ cm. | | kg. |
|-----------------|-------|-----------|------------------|----------------|------------------|--------|
| | | | | Aperta Open | Chiusa Closed | |
| O 00 16 013 | | Bici-Bike | Nero-Black | 73x30x43 | 140x55x95 | 13,000 |



made by



CAMBIO SHIMANO 6 MARCE
SHIMANO GEARS 6 SPEEDS

SUGGESTED ITEM



Art. O0080013
(pag. 594)

Prima di essere utilizzate, le bici acquistate devono essere da Voi registrate
Please register your bikes before first use

RUOTE-WHEELS 16"



Cestino-Trolley doppio uso

Adatto per bicicletta e ideale come contenitore per la spesa.

Multi basket trolley

Suitable for use on bicycle and as a shopping basket.

| Articolo - Item | €/pc. | Colore-Colour | ↕ cm. | | kg. |
|-----------------|-------|---------------|----------|--|-------|
| | | | | | |
| O 00 40 080 | | Nero-Black | 40x32x29 | | 1,000 |



made by



Sacca portabici

Realizzata in acciaio verniciato.
Sella in poliuretano.
Provvista di ruote da 20".
Parafanghi in plastica.

Bike/holder bag

Manufactured in painted steel.
Polyurethane saddle.
Provided with 20" wheels.
Plastic fenders.

| Articolo - Item | €/pc. | Colore-Colour | ↕ cm. | | kg. |
|-----------------|-------|---------------|----------|--|-------|
| | | | | | |
| O 00 80 013 | | Nero-Black | 75x56x28 | | 0,300 |



ESPOSITORI CIME | ROPE DISPLAYS

Espositore per cime

Fornito vuoto.
Provvisto di contimetri.

Self-stand display

Supplied empty.
With built-in meter counter.

| Articolo - Item | €/pc. | H cm. | Larghezza-Width cm. | kg. |
|-----------------|-------|-------|---------------------|--------|
| T 20 00 025 | | 190 | 80 | 13,300 |



COMPLETE WITH



Art. F0100060
(pag. 43)



Espositore per cime a parete

Fornito vuoto.

Self-stand display

Supplied empty.

| Articolo - Item | €/pc. | H cm. | Larghezza-Width cm. | kg. |
|-----------------|-------|-------|---------------------|--------|
| T 50 00 001 | | 200 | 130 | 33,500 |



SUGGESTED ITEM



Art. F0100060
(pag. 43)



ESPOSITORI | DISPLAYS

Espositore vuoto generico

Generic empty display

| Articolo - Item | €/pc. | H cm. | Larghezza-Width cm. | Profondità-Depth cm. |
|-----------------|-------|-------|---------------------|----------------------|
| V 25 74 000 | | 150 | 80 | 40 |



Espositore vuoto generico

Generic empty display

| Articolo - Item | €/pc. | H cm. | Larghezza-Width cm. | Profondità-Depth cm. |
|-----------------|-------|-------|---------------------|----------------------|
| O 42 00 001 | | 187 | 91 | 38 |



Espositore per lampadine a led

Display for led bulbs

| Articolo - Item | €/pc. | Mod. | mm. |
|-----------------|-------|---------------------------|----------------|
| L 44 04 625 | | Vuoto-Empty | H500xL305xP140 |
| L 44 00 000 | | Kit completo-Complete kit | H500xL305xP140 |



Modello completo
Complete model

| Complete with: | Pcs. |
|----------------|------|
| L44 12 156 | 2 |
| L44 20 200 | 2 |
| L44 20 215 | 2 |
| L44 10 031B | 2 |
| L44 06 023 | 2 |
| L43 06 023 | 2 |
| L44 09 028 | 2 |
| L43 09 028 | 2 |
| L44 12 030 | 2 |
| L43 12 030 | 2 |
| L44 10 039B | 2 |
| L43 10 039B | 2 |
| L44 10 044B | 2 |
| L43 10 044B | 2 |

ESPOSITORI «T-BRITE» | «T-BRITE» DISPLAYS

Espositore per prodotti di pulizia «T-Brite»

Display for «T-Brite» cleaning products

| Articolo - Item | €/pc. | Mod. | mm. |
|-----------------|-------|-------------|-----------------|
| R 38 04 619 | | Vuoto-Empty | H2050xL970xP460 |



Espositore per prodotti di pulizia «T-Brite»

Display for «T-Brite» cleaning products

| Articolo - Item | €/pc. | Mod. |
|-----------------|-------|-------------|
| R 38 00 001 | | Vuoto-Empty |

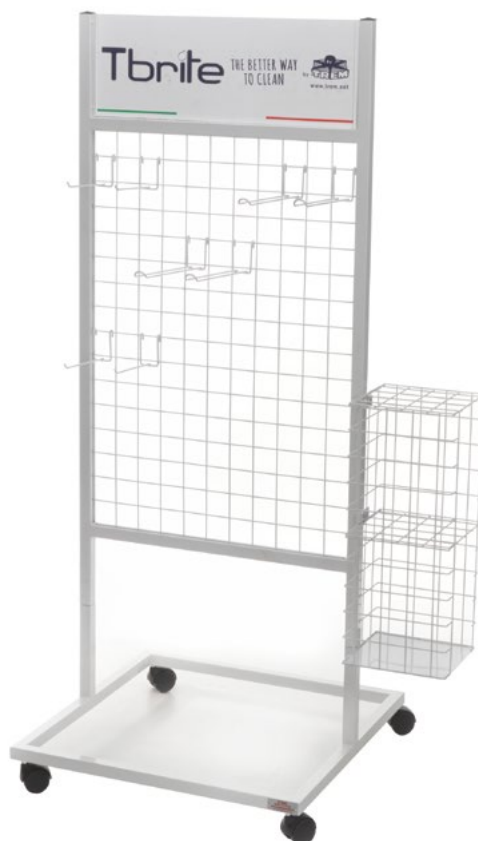

Espositore per luci di via Display for navigation lights

| Articolo - Item | €/pc. | Mod. | ↑ ↓ mm. |
|-----------------|-------|---------------------------|-----------------|
| L 36 04 606 | | Vuoto-Empty | H1560xL760xP420 |
| L 36 00 000 | | Kit completo-Complete kit | H1560xL760xP420 |



Modello completo Complete model

| Completo di Complete with: | Colore corpo Body colour | Colore luce Light colour | Gradi ° | Pcs. | Completo di Complete with: | Colore corpo Body colour | Colore luce Light colour | Gradi ° | Pcs. |
|----------------------------|--------------------------|--------------------------|---------|------|----------------------------|--------------------------|--------------------------|---------|------|
| L 36 80 530 | Nero | ■ | 112,5° | 2 | L 57 80 530 | Nero | ■ | 112,5° | 1 |
| L 36 80 550 | Nero | ■ | 112,5° | 2 | L 57 80 550 | Nero | ■ | 112,5° | 1 |
| L 36 80 560 | Nero | □ | 225° | 2 | L 57 80 560 | Nero | □ | 225° | 1 |
| L 36 80 580 | Nero | □ | 135° | 2 | L 57 80 580 | Nero | □ | 135° | 1 |
| L 36 74 530 | Bianco | ■ | 112,5° | 3 | L 57 74 530 | Bianco | ■ | 112,5° | 2 |
| L 36 74 550 | Bianco | ■ | 112,5° | 3 | L 57 74 550 | Bianco | ■ | 112,5° | 2 |
| L 36 74 560 | Bianco | □ | 225° | 3 | L 57 74 560 | Bianco | □ | 225° | 2 |
| L 36 74 580 | Bianco | □ | 135° | 3 | L 57 74 580 | Bianco | □ | 135° | 2 |
| L 58 80 530 | Nero | ■ | 112,5° | 1 | L 38 01 530 | Nero | □ | 360° | 2 |
| L 58 80 550 | Nero | ■ | 112,5° | 1 | L 41 01 530 | Bianco | □ | 360° | 3 |
| L 58 80 560 | Nero | □ | 225° | 1 | L 41 01 360 | Bianco | □ | 360° | 2 |
| L 58 80 580 | Nero | □ | 135° | 1 | L 74 74 610 | Bianco | ■ | 225° | 2 |
| L 58 74 530 | Bianco | ■ | 112,5° | 6 | L 38 74 360 | Nero | □ | 360° | 2 |
| L 58 74 550 | Bianco | ■ | 112,5° | 6 | L 41 74 360 | Bianco | □ | 360° | 6 |
| L 58 74 560 | Bianco | □ | 225° | 6 | L 41 14 360 | Bianco | □ | 360° | 4 |
| L 58 74 580 | Bianco | □ | 135° | 6 | L 74 74 360 | Bianco | □ | 360° | 1 |
| L 59 74 530 | Bianco | ■ | 112,5° | 2 | | | | | |
| L 59 74 550 | Bianco | ■ | 112,5° | 2 | | | | | |
| L 59 74 560 | Bianco | □ | 225° | 2 | | | | | |
| L 59 74 580 | Bianco | □ | 135° | 2 | | | | | |
| L 76 74 530 | Bianco | ■ | 112,5° | 2 | | | | | |
| L 76 74 550 | Bianco | ■ | 112,5° | 2 | | | | | |
| L 76 74 560 | Bianco | □ | 135° | 2 | | | | | |
| L 76 74 580 | Bianco | □ | 225° | 2 | | | | | |



ESPOSITORI LUCI SUBACQUEE | UNDERWATER LIGHTS DISPLAYS

Espositore per luci subacquee Display for underwater lights «Aqua Line»

| Articolo - Item | €/pc. | Mod. | ↑ ↓ mm. |
|-----------------|-------|---------------------------|----------------|
| L 46 04 618 | | Espositore dimostrativo | H300xL300xP400 |
| L 43 00 000 | | Kit completo-Complete kit | H300xL300xP400 |



Modello completo Complete model

| Complete with: | Pcs. |
|----------------|------|
| L44 06 012 | 4 |
| L44 80 003 | 2 |
| L44 06 006 | 2 |
| L43 06 006 | 2 |
| L44 06 003 | 6 |
| L43 06 003 | 2 |





Espositore per prodotti acqua Display for water products

| Articolo - Item | €/pc. | Mod. | mm. |
|-----------------|-------|---------------------------|-----------------|
| O 22 04 612 | | Vuoto-Empty | H1870xL910xP380 |
| N 01 00 000 | | Kit completo-Complete kit | H1870xL910xP380 |



Kit completo
Complete kit

| Complete with: | Pcs. |
|----------------|------|
| N 01 25 110 | 20 |
| N 01 00 368 | 20 |
| N 01 25 038 | 20 |
| N 01 05 462 | 5 |
| N 01 10 462 | 5 |
| N 01 00 250 | 20 |
| N 01 00 400 | 20 |
| N 01 00 258 | 10 |
| N 01 70 250 | 2 |
| N 01 70 400 | 2 |
| N 01 70 251 | 2 |
| N 01 68 250 | 2 |
| N 01 18 250 | 2 |
| N 01 18 258 | 2 |
| N 01 00 311 | 2 |
| N 01 00 315 | 2 |
| N 01 15 130 | 2 |
| N 01 03 110 | 2 |
| N 01 00 195 | 1 |
| Z 08 24 375 | 1 |
| Z 08 20 090 | 2 |
| N 01 14 201 | 2 |
| N 01 20 201 | 2 |
| N 01 02 212 | 2 |
| N 01 02 251 | 2 |
| Z 08 32 026 | 1 |

ESPOSITORI TELI | COVERS DISPLAYS



Espositore telii «Covy Line»

Display for «Covy Line» covers

| Articolo - Item | €/pc. | Mod. | mm. |
|-----------------|-------|---------------------------|-----------------|
| O 22 00 000 | | Kit completo-Complete kit | H1870xL910xP380 |



Kit completo
Complete kit

| Complete with: | Taglia-Size | Pcs. |
|----------------|--------------|------|
| O 22 85 090 | S | 3 |
| O 22 65 120 | M | 3 |
| O 22 70 140 | L | 3 |
| O 22 90 140 | XL | 3 |
| O 22 24 300 | Tender | 1 |
| O 22 30 360 | Maxi Tender | 1 |
| O 22 18 488 | XXS | 2 |
| O 22 22 488 | XS | 2 |
| O 22 23 488 | S | 2 |
| O 22 24 579 | M | 2 |
| O 22 26 610 | L | 2 |
| O 22 29 650 | XL | 2 |
| O 22 38 710 | XXL | 2 |
| O 22 70 780 | Maxi | 1 |
| O 22 36 300 | Coprimoto | 1 |
| O 22 25 075 | S | 2 |
| O 22 15 087 | M | 2 |
| O 22 18 145 | L | 2 |
| O 22 21 170 | XL | 2 |
| O 22 00 100 | fino a 100HP | 1 |
| O 22 00 101 | oltre 100HP | 1 |
| O 22 25 040 | XXS | 2 |
| O 22 27 048 | XS | 2 |
| O 22 35 063 | M | 2 |
| O 22 40 073 | L | 2 |

Espositore per prodotti «Covy Lux»

Display for «Covy Lux» products

| Articolo - Item | €/pc. | Mod. | mm. |
|-----------------|-------|---------------------------|-----------------|
| O 42 00 000 | | Kit completo-Complete kit | H1870xL910xP380 |



Kit completo
Complete kit

| Complete with: | Taglia-Size | Pcs. |
|----------------|-------------|------|
| O 42 15 087 | M | 2 |
| O 42 18 145 | L | 2 |
| O 42 22 190 | XL | 2 |
| O 42 21 125 | MAXI | 2 |
| O 42 90 140 | L | 2 |
| O 42 99 140 | XL | 2 |
| O 42 23 488 | S | 1 |
| O 42 24 579 | M | 1 |
| O 42 26 610 | L | 1 |
| O 42 29 650 | XL | 1 |
| O 42 14 160 | 160 x 145 | 2 |
| O 42 15 180 | 180 x 150 | 2 |
| O 42 20 170 | 200 x 170 | 2 |
| O 42 33 055 | S | 2 |
| O 42 35 063 | M | 2 |
| O 42 40 073 | L | 2 |
| O 42 45 075 | XL | 2 |



Espositore per prodotti «Covy Line» e «Covy Lux»

Display for «Covy Line» and «Covy Lux» products

| Articolo - Item | €/pc. | Mod. | mm. |
|-----------------|-------|---------------------------|-----------------|
| O 22 42 000 | | Kit completo-Complete kit | H1870xL910xP380 |



Kit completo
Complete kit

| Complete with: | Taglia-Size | Pcs. | Complete with: | Taglia-Size | Pcs. |
|----------------|--------------|------|----------------|-------------|------|
| O 22 25 040 | XXS | 1 | O 42 90 140 | L | 2 |
| O 22 27 048 | XS | 1 | O 42 99 140 | XL | 2 |
| O 22 35 063 | M | 1 | O 42 15 087 | M | 1 |
| O 22 40 073 | L | 1 | O 42 18 145 | L | 1 |
| O 42 14 160 | 160 x 145 | 2 | O 42 22 190 | XL | 1 |
| O 42 15 180 | 180 x 150 | 2 | O 42 21 125 | MAXI | 1 |
| O 42 20 170 | 200 x 170 | 2 | O 42 33 055 | S | 1 |
| O 22 00 100 | fino a 100HP | 1 | O 42 35 063 | M | 1 |
| O 22 00 101 | oltre 100HP | 1 | O 42 40 073 | L | 1 |
| O 22 25 075 | S | 1 | O 42 45 075 | XL | 1 |
| O 22 15 087 | M | 1 | O 42 23 488 | S | 1 |
| O 22 18 145 | L | 1 | O 42 24 579 | M | 1 |
| O 22 85 090 | S | 1 | O 42 26 610 | L | 1 |
| O 22 65 120 | M | 2 | O 42 29 650 | XL | 1 |
| O 22 70 140 | L | 2 | | | |
| O 22 90 140 | XL | 2 | | | |
| O 22 24 579 | M | 1 | | | |
| O 22 26 610 | L | 1 | | | |
| O 22 29 650 | XL | 1 | | | |
| O 22 36 300 | Coprimoto | 1 | | | |



| | | | | | | | | | | | | | | | | | |
|----------|-----|----------|-----|-----------|-----|-----------|-----|-----------|-----|-----------|-----|----------|-----|----------|-----|----------|-----|
| A | | B1822004 | 102 | C1004050 | 34 | D1000014 | 592 | D1749150 | 581 | D3275000 | 593 | E2950340 | 405 | E3940604 | 397 | E5135160 | 94 |
| A2100020 | 42 | B1900070 | 103 | C1005000 | 34 | D1000042 | 116 | D1750063 | 585 | D3277000 | 593 | E2950350 | 405 | E3944180 | 397 | E5139160 | 94 |
| A2206020 | 576 | B1900080 | 103 | C1005000W | 34 | D1001028 | 377 | D1750363 | 586 | D3282000 | 593 | E2950425 | 405 | E4000200 | 396 | E5139250 | 94 |
| A2214000 | 41 | B1900090 | 103 | C1005050 | 34 | D1006039 | 372 | D1755091 | 581 | D3920020 | 593 | E2950430 | 405 | E4000400 | 396 | E5139320 | 94 |
| A2214020 | 41 | B1900100 | 103 | C1006000 | 34 | D1008020 | 378 | D1755191 | 583 | D3950050 | 363 | E2950538 | 405 | E4300180 | 399 | E5148250 | 94 |
| A2216000 | 41 | B1900110 | 103 | C1006000W | 34 | D1011084 | 372 | D1760030 | 587 | D4336000 | 565 | E2950550 | 405 | E4352009 | 400 | E5148320 | 94 |
| A2216020 | 41 | B1900120 | 103 | C1006050 | 34 | D1015035 | 378 | D1760060 | 587 | D4340000 | 565 | E2950563 | 405 | E4400180 | 399 | E5148380 | 94 |
| A2217000 | 41 | B1900130 | 103 | C1008000 | 34 | D1015045 | 378 | D1760070 | 587 | D5312063 | 85 | E2950714 | 405 | E4500180 | 399 | E5203020 | 94 |
| A2217020 | 41 | B1910043 | 103 | C1008000W | 34 | D1018370 | 367 | D1760098 | 584 | D5312064 | 85 | E3405004 | 96 | E4650084 | 400 | E5204040 | 94 |
| A3108060 | 35 | B1910045 | 103 | C1008050 | 34 | D1025030 | 377 | D1760100 | 584 | D5360204 | 85 | E3405044 | 96 | E4652009 | 400 | E5205050 | 94 |
| A3108100 | 35 | B1910080 | 101 | C1010000 | 34 | D1025036 | 378 | D1760313 | 586 | D5360204H | 85 | E3515095 | 400 | E4674050 | 400 | E5205060 | 94 |
| B | | B1910103 | 101 | C1010050 | 34 | D1026020 | 377 | D1760393 | 586 | D5360205 | 85 | E3519080 | 400 | E4679050 | 400 | E5305030 | 94 |
| B0015009 | 115 | B1915080 | 101 | C1012050 | 34 | D1030036 | 378 | D1770074 | 586 | D5380264 | 85 | E3577150 | 400 | E4680050 | 400 | E5305035 | 94 |
| B0040070 | 115 | B1915103 | 101 | C1014050 | 34 | D1030037 | 372 | D1770079 | 586 | D5380265 | 85 | E3582300 | 400 | E4700180 | 399 | E5305040 | 94 |
| B0560110 | 376 | B1930001 | 103 | C1100000 | 35 | D1034025 | 377 | D1771093 | 585 | D5380284 | 84 | E3711068 | 398 | E4800000 | 395 | E5305050 | 94 |
| B0620009 | 376 | B1940001 | 103 | C1304000 | 41 | D1040030 | 378 | D1771113 | 585 | E | | E3725005 | 400 | E4800180 | 399 | E5306020 | 94 |
| B0640010 | 376 | B1943140 | 103 | C1304013 | 41 | D1040050 | 378 | D1772140 | 584 | E0001008 | 112 | E3774252 | 398 | E4800250 | 394 | E5306035 | 94 |
| B0660011 | 376 | B1950001 | 103 | C1304015 | 41 | D1042033 | 93 | D1774004 | 587 | E0002013 | 112 | E3774291 | 398 | E4800750 | 394 | E5306040 | 94 |
| B0702290 | 374 | B1970001 | 103 | C1306000 | 41 | D1074370 | 367 | D1774070 | 587 | E0013020 | 112 | E3774292 | 398 | E4801000 | 394 | E5306050 | 94 |
| B0770028 | 375 | B1980001 | 103 | C1306011 | 40 | D1075355 | 377 | D1774086G | 581 | E0045065 | 112 | E3774295 | 398 | E4801001 | 394 | E5306060 | 94 |
| B0779011 | 376 | B1990001 | 103 | C1308000 | 41 | D1082803 | 377 | D1774086V | 581 | E0300012 | 571 | E3774521 | 398 | E4801002 | 394 | E5402035 | 95 |
| B0779018 | 376 | B1995001 | 103 | C1308012 | 41 | D1082805 | 377 | D1774110 | 587 | E0300050 | 571 | E3780290 | 398 | E4801003 | 395 | E5403040 | 95 |
| B0779028 | 376 | B3825110 | 121 | C1310000 | 41 | D1082807 | 377 | D1774155 | 587 | E0310055 | 571 | E3780291 | 398 | E4801004 | 395 | E5404000 | 95 |
| B0779037 | 376 | B3900001 | 101 | C1310014 | 41 | D1084054 | 372 | D1774170 | 587 | E0390211 | 350 | E3780295 | 398 | E4801005 | 394 | E5405000 | 95 |
| B0779038 | 375 | B3915001 | 101 | C1320008 | 40 | D1206226 | 590 | D1775150 | 581 | E0390301 | 350 | E3800030 | 399 | E4801006 | 395 | E5406000 | 95 |
| B0779042 | 374 | B4030120 | 590 | C1325008 | 40 | D1282226 | 590 | D1775151 | 582 | E0500150 | 350 | E3800095 | 399 | E4801030 | 394 | E5415025 | 95 |
| B0779046 | 376 | B4337010 | 588 | C1414150 | 36 | D1300001 | 111 | D1775152 | 581 | E0541370 | 350 | E3800120 | 399 | E4801100 | 395 | E5528018 | 95 |
| B0779108 | 376 | B5018300 | 96 | C1414250 | 36 | D1310320 | 111 | D1775158 | 582 | E0900001 | 396 | E3800121 | 399 | E4801500 | 395 | E5532011 | 95 |
| B0779109 | 376 | B5112031 | 590 | C1525300 | 36 | D1310321 | 111 | D1775163 | 583 | E0900002 | 396 | E3800125 | 399 | E4801750 | 394 | E5538016 | 95 |
| B0779110 | 376 | B8329722 | 578 | C1525450 | 36 | D1312018 | 111 | D1775165 | 583 | E0900003 | 396 | E3800250 | 399 | E4802007 | 399 | E5546012 | 95 |
| B0779201 | 374 | B8406001 | 116 | C1525600 | 36 | D1319024 | 111 | D1775191 | 583 | E0900004 | 396 | E3800251 | 399 | E4802750 | 394 | E5546027 | 95 |
| B1000890 | 104 | B8406002 | 116 | C1532600 | 36 | D1323023 | 111 | D1775192 | 582 | E0900009 | 396 | E3800400 | 399 | E4803750 | 394 | E5548014 | 95 |
| B1000900 | 104 | B8408001 | 116 | C1708045 | 37 | D1331043 | 111 | D1776046 | 586 | E0908001 | 396 | E3800401 | 399 | E4804004 | 395 | E5548020 | 95 |
| B1000920 | 104 | B8408002 | 116 | C1740032 | 37 | D1343464S | 111 | D1785115 | 371 | E1000500 | 479 | E3830000 | 399 | E4804750 | 395 | E5550000 | 126 |
| B1040910 | 104 | B8410001 | 116 | C1740080 | 37 | D1350555 | 111 | D1785315 | 371 | E1000700 | 479 | E3870030 | 399 | E4805000 | 394 | E5602021 | 126 |
| B1045910 | 104 | B8410002 | 116 | C1750032 | 37 | D1400922 | 591 | D1785815 | 371 | E1002708 | 479 | E3874030 | 399 | E4805001 | 394 | E5604000 | 95 |
| B1400051 | 105 | B9806001 | 116 | C1750034 | 37 | D1400130 | 591 | D1790000 | 320 | E1005009 | 479 | E3874031 | 399 | E4805003 | 395 | E5605000 | 95 |
| B1400200 | 108 | B9808001 | 116 | C2103020 | 34 | D1400160 | 591 | D1791152 | 581 | E1005600 | 479 | E3875031 | 399 | E4805006 | 395 | E5606000 | 95 |
| B1400205 | 108 | B9810001 | 116 | C2505015 | 40 | D1400190 | 591 | D1801075 | 582 | E1006000 | 479 | E3879030 | 399 | E4805030 | 394 | E5608000 | 95 |
| B1402077 | 106 | B9812001 | 116 | C2506010 | 39 | D1400923 | 591 | D1801078 | 582 | E1006002 | 479 | E3879031 | 399 | E4805750 | 395 | E5620074 | 93 |
| B1402150 | 108 | C | | C2506015 | 40 | D1400958 | 591 | D1802075 | 582 | E1006009 | 479 | E3880030 | 399 | E4808030 | 395 | E5620080 | 93 |
| B1402200 | 106 | C0004020 | 35 | C2508012 | 39 | D1500020 | 251 | D2000030 | 568 | E1006013 | 479 | E3880031 | 399 | E4808120 | 395 | E5645074 | 93 |
| B1403077 | 106 | C0004030 | 35 | C2508015 | 40 | D1513017 | 126 | D2000039 | 569 | E1006200 | 479 | E3900151 | 397 | E4808240 | 395 | E5645080 | 93 |
| B1403200 | 108 | C0006030 | 35 | C2604000 | 41 | D1516024 | 126 | D2000042 | 569 | E1006601 | 479 | E3900180 | 397 | E4850065 | 394 | E5645174 | 93 |
| B1420000 | 105 | C0008050 | 35 | C2604015 | 41 | D1519028 | 126 | D2000056 | 569 | E1006609 | 479 | E3940010 | 396 | E4852009 | 400 | E5645180 | 93 |
| B1420002 | 106 | C0010100 | 35 | C2606000 | 41 | D1528019 | 126 | D2000060 | 569 | E1006614 | 479 | E3940015 | 396 | E4952009 | 400 | E5650000 | 126 |
| B1420003 | 106 | C0206035 | 35 | C2608000 | 41 | D1600050 | 401 | D2000071 | 569 | E1006615 | 479 | E3940050 | 404 | E5029013 | 94 | E5655074 | 93 |
| B1420062 | 105 | C0206055 | 35 | C2608019 | 40 | D1605000 | 401 | D2000081 | 568 | E1006900 | 479 | E3940051 | 404 | E5029019 | 94 | E5655174 | 93 |
| B1420200 | 105 | C0304030 | 35 | C2608074 | 40 | D1605002 | 401 | D2002055 | 569 | E1007000 | 479 | E3940052 | 404 | E5029095 | 94 | E5655180 | 93 |
| B1423001 | 107 | C0304040 | 35 | C2620008 | 40 | D1605003 | 401 | D2002171 | 569 | E1007010 | 479 | E3940053 | 404 | E5029127 | 94 | E5704000 | 95 |
| B1423002 | 107 | C0304050 | 35 | C2625008 | 40 | D1610000 | 401 | D2002205 | 569 | E1007067 | 479 | E3940054 | 404 | E5029190 | 94 | E5705000 | 95 |
| B1423101 | 107 | C0304060 | 35 | C2805074 | 40 | D1650079 | 401 | D2002210 | 569 | E1007200 | 479 | E3940055 | 404 | E5029250 | 94 | E5706000 | 95 |
| B1423102 | 107 | C0404020 | 35 | C2805080 | 40 | D1700074 | 371 | D2003185 | 569 | E1007410 | 479 | E3940056 | 404 | E5035013 | 94 | E5708000 | 95 |
| B1423103 | 107 | C0404035 | 35 | C2806080 | 40 | D1700130 | 566 | D2004051 | 569 | E1007900 | 479 | E3940058 | 404 | E5035016 | 94 | E5710000 | 95 |
| B1460090 | 105 | C0404055 | 35 | C3125150 | 36 | D1700155 | 587 | D2006025 | 568 | E1008000 | 479 | E3940060 | 404 | E5035130 | 94 | E5805010 | 94 |
| B1480120 | 105 | C0480028 | 35 | C3125250 | 36 | D1700163 | 370 | D2006026 | 568 | E1008010 | 479 | E3940063 | 404 | E5039019 | 94 | E5805035 | 94 |
| B1590130 | 105 | C0508200 | 35 | C3125400 | 36 | D1700170 | 587 | D2006027 | 568 | E1008100 | 479 | E3940064 | 404 | E5039025 | 94 | E5904000 | 95 |
| B1600100 | 571 | C0508300 | 35 | C3550750 | 360 | D1701070 | 585 | D2006043 | 568 | E1008310 | 479 | E3940066 | 404 | E5039190 | 94 | E5905000 | 95 |
| B1600150 | 571 | C0510300 | 35 | C7505000 | 34 | D1703070 | 585 | D2016015 | 569 | E1008400 | 479 | E3940067 | 404 | E5039250 | 94 | E5906000 | 95 |
| B1619044 | 589 | C0606030 | 35 | C7506000 | 34 | D1712563 | 321 | D2030000 | 570 | E1008410 | 479 | E3940068 | 404 | E5042016 | 94 | E5908000 | 95 |
| B1620038 | 589 | C0608050 | 35 | C7705000 | 34 | D1715001 | 370 | D2122008 | 567 | E1008450 | 479 | E3940069 | 404 | E5042019 | 94 | E5910000 | 95 |
| B1637010 | 588 | C0608075 | 35 | C7706000 | 34 | D1715002 | 370 | D2124009 | 567 | E1008500 | 479 | E3940071 | 404 | E5042025 | 94 | E6000020 | 452 |
| B1637025 | 588 | C0610060 | 35 | C7805000 | 34 | D1715005 | 370 | D2500015 | 126 | E1009010 | 479 | E3940075 | 404 | E5042032 | 94 | E6000032 | 452 |
| B1637037 | 588 | C0610075 | 35 | C7806000 | 34 | D1715007 | 370 | D2600015 | 126 | E1009410 | 479 | E3940077 | 404 | E5042160 | 94 | E6000051 | 452 |
| B1674010 | 588 | C0610100 | 35 | C8003000 | 34 | D1720160 | 321 | D2732030 | 566 | E2800020 | 396 | E3940080 | 404 | E5042250 | 94 | E6000070 | 452 |
| B1675010 | 588 | C0610150 | 35 | C8004000 | 34 | D1722025 | 371 | D2750150 | 566 | E2800200 | 396 | E3940081 | 404 | E5048025 | 94 | E6000089 | 452 |
| B1675037 | 588 | C0705055 | 35 | C8005000 | 34 | D1725055 | 583 | D2775000 | 566 | E2800400 | 396 | E3940083 | 404 | E5048032 | 94 | E6000108 | 452 |
| B1675040 | 589 | C0706075 | 35 | C8006000 | 34 | D1732075 | 370 | D2900000 | 401 | E28 | | | | | | | |

| | | | | | | | | | | | | | | | | | |
|----------|----------|----------|----|----------|-----|----------|-----|-----------|-----|----------|----------|----------|-----|----------|-----|----------|-----|
| E7074075 | 402 | F4712000 | 26 | F9006000 | 20 | K0611003 | 202 | K1307039 | 212 | K3301045 | 219 | L0570413 | 255 | L0610081 | 251 | L0630519 | 261 |
| E7074250 | 402 | F4712007 | 25 | F9008000 | 20 | K0901148 | 199 | K1307040 | 212 | K3301478 | 219 | L0579001 | 256 | L0610089 | 230 | L0631013 | 239 |
| E7075075 | 402 | F4712207 | 25 | F9010000 | 20 | K0902145 | 199 | K1307041 | 212 | K3302143 | 213 | L0579101 | 256 | L0610090 | 228 | L0632003 | 250 |
| E7080075 | 402 | F4714000 | 26 | F9012000 | 20 | K0907700 | 204 | K1307042 | 212 | K3304353 | 219 | L0580413 | 255 | L0610091 | 230 | L0632004 | 250 |
| E7080250 | 402 | F4714009 | 25 | F9106000 | 20 | K0907701 | 199 | K1307044 | 212 | K3307480 | 219 | L0600001 | 250 | L0610136 | 245 | L0632005 | 250 |
| E7082250 | 402 | F4714209 | 25 | F9108000 | 20 | K0907702 | 204 | K1307046 | 212 | K3307481 | 219 | L0600012 | 241 | L0610142 | 245 | | |
| E7275250 | 402 | F4716000 | 26 | F9110000 | 20 | K0907712 | 204 | K1307083 | 213 | K3307484 | 219 | L0600030 | 240 | L0610162 | 245 | L0636007 | 251 |
| E7280075 | 402 | F4716011 | 25 | F9406075 | 18 | K0909012 | 199 | K1307086 | 213 | K3307485 | 219 | L0600080 | 479 | L0610180 | 229 | L0636048 | 239 |
| E7280250 | 402 | F4716211 | 25 | F9406080 | 18 | K1007601 | 204 | K1307087 | 213 | K3308033 | 216 | L0600092 | 228 | L0610192 | 228 | L0637103 | 250 |
| E7282250 | 402 | F4718000 | 26 | F9406082 | 18 | K1007610 | 205 | K1307088 | 213 | K3308134 | 216 | L0600093 | 228 | L0610270 | 252 | L0638080 | 239 |
| E7373075 | 402 | F4718012 | 25 | F9408075 | 18 | K1105101 | 208 | K1307089 | 213 | K3308166 | 216 | L0600130 | 479 | L0610271 | 252 | L0638085 | 239 |
| E7373250 | 402 | F4718212 | 25 | F9408080 | 18 | K1105102 | 208 | K1307136 | 212 | K3308167 | 216 | L0600191 | 240 | L0610272 | 252 | L0638090 | 239 |
| E7374075 | 402 | F4720000 | 26 | F9408082 | 18 | K1105103 | 208 | K1307138 | 212 | K3308171 | 216 | L0600192 | 240 | L0610274 | 252 | L0640200 | 233 |
| E7374250 | 402 | F4720013 | 25 | F9410075 | 18 | K1105104 | 208 | K1307139 | 212 | K3308172 | 216 | L0600244 | 241 | L0610503 | 261 | L0642110 | 239 |
| E7375075 | 402 | F4720213 | 25 | F9410080 | 18 | K1105105 | 208 | K1307140 | 212 | K3374011 | 219 | L0600400 | 230 | L0610519 | 261 | L0642115 | 239 |
| E7375250 | 402 | F4722000 | 26 | F9410082 | 18 | K1105107 | 208 | K1307141 | 212 | K3374016 | 219 | L0600588 | 242 | L0610582 | 263 | L0642120 | 239 |
| E7380075 | 402 | F4724000 | 26 | F9412075 | 18 | K1105122 | 208 | K1307142 | 212 | K3408358 | 217 | L0600640 | 242 | L0610595 | 243 | L0644002 | 250 |
| E7380250 | 402 | F4726000 | 26 | F9412080 | 18 | K1105123 | 208 | K1307146 | 212 | K3408359 | 217 | L0600644 | 242 | L0610599 | 243 | L0644005 | 251 |
| E7382250 | 402 | F5005000 | 19 | F9412082 | 18 | K1105124 | 208 | K1307182 | 212 | K3508235 | 220 | L0600785 | 242 | L0610615 | 253 | L0650505 | 261 |
| E7473075 | 402 | F5006000 | 19 | F9414075 | 18 | K1105125 | 208 | K1307183 | 212 | K3508236 | 220 | L0601033 | 250 | L0610814 | 231 | L0660004 | 244 |
| E7473250 | 402 | F5008000 | 19 | F9414080 | 18 | K1105126 | 208 | K1307184 | 212 | K3508251 | 220 | L0601119 | 253 | L0610815 | 231 | L0660006 | 244 |
| E7475075 | 402 | F5010000 | 19 | F9414082 | 18 | K1105127 | 208 | K1307185 | 212 | K3608003 | 220 | L0601210 | 45 | L0610816 | 231 | L0660008 | 244 |
| E7475250 | 402 | F5012000 | 19 | | | K1105128 | 208 | K1307186 | 212 | K3608005 | 220 | L0601220 | 45 | L0611000 | 251 | L0660011 | 244 |
| E7480075 | 402 | F5105000 | 19 | H1003396 | 274 | K1105129 | 208 | K1307187 | 212 | K3608017 | 220 | L0601331 | 240 | L0611517 | 263 | L0660012 | 244 |
| E7482075 | 402 | F5106000 | 19 | H1008000 | 42 | K1105131 | 208 | K1307188 | 212 | K3608022 | 220 | L0601332 | 241 | L0612000 | 252 | L0660013 | 244 |
| E7531075 | 403 | F5108000 | 19 | H1008237 | 42 | K1105133 | 208 | K1407202 | 215 | K3608240 | 220 | L0601333 | 241 | L0612008 | 240 | L0660014 | 244 |
| E7674075 | 403 | F5110000 | 19 | H1032030 | 42 | K1105135 | 208 | K1407206 | 215 | K3608254 | 220 | L0601335 | 240 | L0612030 | 253 | L0660015 | 244 |
| E7674375 | 403 | F5112000 | 19 | H1032065 | 42 | K1105136 | 208 | K1407210 | 215 | K3609230 | 220 | L0601338 | 241 | L0612054 | 248 | L0660016 | 244 |
| E7679075 | 403 | F5205000 | 19 | H1235000 | 42 | K1105137 | 208 | K1407214 | 215 | K3708237 | 221 | L0601342 | 242 | L0612056 | 248 | L0660017 | 244 |
| E7701075 | 403 | F5206000 | 19 | | | K1105138 | 208 | K1407218 | 215 | K3708247 | 221 | L0601392 | 228 | L0612075 | 257 | L0660018 | 246 |
| E7702075 | 403 | F5208000 | 19 | K0004011 | 198 | K1105139 | 208 | K1407222 | 215 | K3808073 | 221 | L0601611 | 262 | L0612082 | 257 | L0660019 | 246 |
| E7979013 | 403 | F5210000 | 19 | K0004012 | 198 | K1105175 | 209 | K1407233 | 215 | K3808258 | 221 | L0601613 | 262 | L0612100 | 245 | L0660086 | 246 |
| | F | F5212000 | 19 | K0004013 | 198 | K1105176 | 209 | K1407246 | 215 | K3809354 | 221 | L0602110 | 263 | L0612101 | 245 | L0660088 | 246 |
| F0000018 | 39 | F5305082 | 20 | K0004015 | 198 | K1105177 | 209 | K1407260 | 215 | K3901052 | 221 | L0602145 | 45 | L0612120 | 230 | L0660505 | 261 |
| F0000027 | 39 | F5308082 | 20 | K0004018 | 198 | K1105178 | 209 | K1407400 | 214 | | L | L0602348 | 242 | L0612130 | 45 | L0661003 | 250 |
| F0006000 | 74 | F5608000 | 23 | K0005990 | 198 | K1105180 | 209 | K1407402 | 214 | L0012120 | 268 | L0602435 | 243 | L0612180 | 230 | L0661006 | 251 |
| F0100024 | 43 | F6204075 | 18 | K0005991 | 198 | K1105181 | 209 | K1407403 | 214 | L0015013 | 268 | L0602611 | 262 | L0612300 | 232 | L0661103 | 251 |
| F0100060 | 43 | F6204080 | 18 | K0101001 | 203 | K1105182 | 209 | K1407404 | 214 | L0015017 | 268 | L0602613 | 262 | L0612317 | 233 | L0661104 | 251 |
| F0100150 | 39 | F6204082 | 18 | K0202002 | 198 | K1105183 | 209 | K1407425 | 214 | L0015018 | 268 | L0603000 | 245 | L0612350 | 228 | L0661105 | 251 |
| F0100175 | 39 | F6205075 | 18 | K0202003 | 198 | K1105184 | 209 | K1407427 | 214 | L0015023 | 268 | L0603028 | 243 | L0612502 | 274 | L0664004 | 251 |
| F0100210 | 39 | F6205080 | 18 | K0202011 | 198 | K1105185 | 209 | K1407428 | 214 | L0022350 | 268 | L0603603 | 243 | L0612600 | 232 | L0665004 | 250 |
| F0100229 | 39 | F6205082 | 18 | K0202201 | 198 | K1105187 | 209 | K1407429 | 214 | L0030200 | 113 | L0603618 | 261 | L0612612 | 262 | L0665005 | 250 |
| F0132175 | 39 | F6206075 | 18 | K0202202 | 198 | K1105189 | 209 | K1407430 | 214 | L0092100 | 268 | L0604000 | 245 | L0613065 | 229 | L0670002 | 229 |
| F0200110 | 43 | F6206080 | 18 | K0202203 | 198 | K1105190 | 209 | K1508219 | 216 | L0100450 | 113 | L0604020 | 263 | L0613066 | 230 | L0670505 | 261 |
| F0214600 | 74 | F6206082 | 18 | K0202204 | 198 | K1105204 | 208 | K1508221 | 216 | L0100500 | 113 | L0605081 | 251 | L0615012 | 45 | L0674000 | 230 |
| F0218900 | 74 | F6208075 | 18 | K0302408 | 203 | K1105206 | 208 | K1508222 | 216 | L0100800 | 113 | L0605147 | 247 | L0615061 | 251 | L0674016 | 247 |
| F0279803 | 43 | F6208080 | 18 | K0302410 | 203 | K1105208 | 208 | K1508230 | 216 | L0120001 | 113 | L0605519 | 261 | L0615081 | 251 | L0674044 | 246 |
| F0300011 | 43 | F6208082 | 18 | K0302506 | 203 | K1105209 | 208 | K1508233 | 216 | L0200040 | 113 | L0605615 | 253 | L0615191 | 241 | L0674063 | 257 |
| F0379102 | 43 | F6210075 | 18 | K0302512 | 203 | K1105210 | 208 | K1508234 | 216 | L0200108 | 269 | L0606000 | 245 | L0615519 | 261 | L0674064 | 246 |
| F2301050 | 32 | F6210080 | 18 | K0302604 | 203 | K1105212 | 208 | K1508266 | 216 | L0200480 | 113 | L0606001 | 245 | L0615615 | 253 | L0674163 | 257 |
| F2305100 | 32 | F6210082 | 18 | K0309216 | 203 | K1105219 | 208 | K1508267 | 216 | L0212105 | 269 | L0606062 | 248 | L0616020 | 252 | L0674435 | 243 |
| F2315035 | 32 | F6906075 | 22 | K0309217 | 203 | K1105250 | 209 | K1508275 | 216 | L0213008 | 268 | L0606102 | 269 | L0616360 | 248 | L0674516 | 243 |
| F2375100 | 32 | F6906077 | 22 | K0309218 | 203 | K1105251 | 209 | K1508294 | 216 | L0215250 | 113 | L0606606 | 262 | L0617115 | 245 | L0675020 | 257 |
| F2380100 | 32 | F6906082 | 22 | K0502104 | 206 | K1105252 | 209 | K1508295 | 216 | L0233105 | 269 | L0608003 | 239 | L0617540 | 230 | L0675120 | 257 |
| F2400100 | 571 | F6908077 | 22 | K0502107 | 206 | K1105253 | 209 | K1508296 | 216 | L0270502 | 113 | L0608005 | 252 | L0618060 | 251 | L0680013 | 247 |
| F4512007 | 25 | F6910077 | 22 | K0502301 | 207 | K1105254 | 209 | K1602130 | 214 | L0274130 | 269 | L0608020 | 252 | L0619075 | 257 | L0680016 | 250 |
| F4514009 | 25 | F7806000 | 21 | K0502302 | 207 | K1105255 | 209 | K1602132 | 214 | L0300400 | 113 | L0608025 | 250 | L0619082 | 257 | L0682020 | 257 |
| F4516011 | 25 | F7808000 | 21 | K0502303 | 207 | K1105256 | 209 | K1602133 | 214 | L0315250 | 113 | L0608028 | 244 | L0619130 | 248 | L0682063 | 257 |
| F4518012 | 25 | F7810000 | 21 | K0502304 | 206 | K1105257 | 209 | K1602134 | 214 | L0400110 | 113 | L0608044 | 263 | L0620000 | 251 | L0682120 | 257 |
| F4520013 | 25 | F7812000 | 21 | K0502305 | 206 | K1105258 | 209 | K1602135 | 214 | L0500009 | 113 | L0608055 | 252 | L0620012 | 45 | L0682163 | 257 |
| F4610000 | 26 | F7814000 | 21 | K0502306 | 206 | K1105259 | 209 | K1602136 | 214 | L0500413 | 255 | L0608060 | 250 | L0620082 | 251 | L0683002 | 250 |
| F4612000 | 26 | F8006000 | 21 | K0502701 | 206 | K1105260 | 209 | K1602137 | 214 | L0504012 | 256 | L0608150 | 233 | L0620180 | 229 | L0683006 | 250 |
| F4612007 | 25 | F8008000 | 21 | K0502702 | 206 | K1105270 | 208 | K1604135 | 213 | L0510012 | 256 | L0608152 | 263 | L0620519 | 261 | L0683007 | 250 |
| F4612207 | 25 | F8010000 | 21 | K0502708 | 206 | K1205005 | 211 | K1604136 | 213 | L0512003 | 256 | L0608615 | 253 | L0620582 | 263 | L0683008 | 250 |
| F4614000 | 26 | F8012000 | 21 | K0502715 | 207 | K1205021 | 209 | K1604137 | 213 | L0512008 | 256 | L0609055 | 252 | L0622000 | 233 | L0691339 | 246 |
| F4614209 | 25 | F8014000 | 21 | K0502722 | 206 | K1205023 | 205 | K2501229 | 217 | L0512010 | 256 | L0609100 | 248 | L0622030 | 253 | L0691341 | 246 |
| F4616000 | 26 | F8106000 | 21 | K0603000 | 201 | K1205024 | 205 | K2904374G | 218 | L0512016 | 256 | L0610003 | 239 | L0622100 | 232 | L0691342 | 246 |
| F4616011 | 25 | F8108000 | 21 | K0603002 | 201 | K1205025 | 207 | K2904376G | 218 | L0512020 | 256 | L0610024 | | | | | |

| | | | | | | | | | | | | | | | | | |
|----------|-----|-----------|-----|----------|-----|------------|-----|----------|-----|----------|-----|----------|-----|----------|-----|----------|-----|
| L0701312 | 266 | L1141726 | 159 | L2212022 | 169 | L3154047 | 309 | L3274520 | 279 | L3280650 | 286 | L3801101 | 153 | L4380003 | 164 | L4412553 | 182 |
| L0702002 | 254 | L1155000 | 160 | L2212450 | 170 | L3172001 | 308 | L3274521 | 280 | L3280652 | 283 | L3801102 | 155 | L4385003 | 164 | L4412751 | 184 |
| L0702058 | 254 | L1500020 | 223 | L2216110 | 171 | L3174057 | 305 | L3274522 | 280 | L3280653 | 282 | L3801103 | 148 | L4400000 | 596 | L4412753 | 184 |
| L0702078 | 255 | L1500025 | 223 | L2225022 | 169 | L3174075 | 305 | L3274523 | 280 | L3280656 | 278 | L3801230 | 154 | L4400010 | 194 | L4412939 | 189 |
| L0702080 | 254 | L1500220 | 223 | L2225604 | 169 | L3180057 | 305 | L3274530 | 279 | L3280700 | 279 | L3801233 | 149 | L4400075 | 178 | L4413005 | 175 |
| L0702102 | 254 | L1501025 | 226 | L2230105 | 171 | L3180075 | 305 | L3274532 | 279 | L3280718 | 277 | L3801360 | 154 | L4400139 | 191 | L4413085 | 161 |
| L0703002 | 254 | L1501060 | 226 | L2235067 | 167 | L3181030 | 307 | L3274533 | 280 | L3280720 | 277 | L3801363 | 149 | L4400156 | 195 | L4415148 | 191 |
| L0703004 | 254 | L1501101 | 226 | L2250160 | 171 | L3200040 | 122 | L3274534 | 280 | L3280733 | 276 | L3801510 | 154 | L4400158 | 188 | L4416020 | 176 |
| L0703006 | 254 | L1501160 | 226 | L2273099 | 171 | L3200120 | 284 | L3274535 | 280 | L3280734 | 277 | L3801513 | 149 | L4400172 | 190 | L4417055 | 174 |
| L0703058 | 254 | L1501250 | 226 | L2274033 | 171 | L3200300 | 311 | L3274600 | 278 | L3280736 | 276 | L3801530 | 154 | L4400176 | 190 | L4418606 | 187 |
| L0703080 | 254 | L1501341 | 224 | L2274058 | 171 | L3200400 | 285 | L3274601 | 278 | L3280756 | 276 | L3801533 | 149 | L4400181 | 184 | L4418607 | 187 |
| L0703104 | 254 | L1503160 | 226 | L2274601 | 170 | L3200410 | 285 | L3274602 | 282 | L3280760 | 277 | L3801610 | 154 | L4400183 | 184 | L4420053 | 165 |
| L0704080 | 254 | L1503501 | 132 | L2274622 | 170 | L3200533 | 277 | L3274630 | 283 | L3280766 | 276 | L3801613 | 149 | L4400190 | 180 | L4420074 | 165 |
| L0705080 | 254 | L1505006 | 226 | L2280190 | 168 | L3200534 | 277 | L3274631 | 283 | L3280952 | 283 | L3820360 | 155 | L4400191 | 179 | L4420200 | 195 |
| L0705521 | 215 | L1505095 | 227 | L2300049 | 563 | L3208200 | 311 | L3274632 | 284 | L3288061 | 311 | L3874360 | 152 | L4400193 | 186 | L4420215 | 195 |
| L0706078 | 255 | L1505250 | 226 | L2300050 | 563 | L3209000 | 310 | L3274633 | 283 | L3288062 | 311 | L3874363 | 148 | L4400200 | 195 | L4420290 | 183 |
| L0706080 | 254 | L1505251 | 226 | L2300300 | 561 | L3210025 | 286 | L3274652 | 283 | L3400041 | 119 | L3882360 | 152 | L4400211 | 182 | L4422065 | 188 |
| L0707080 | 254 | L1506006 | 226 | L2300301 | 561 | L3210501 | 311 | L3274653 | 282 | L3400043 | 119 | L3900003 | 162 | L4400213 | 180 | L4422077 | 183 |
| L0708080 | 254 | L1506016 | 227 | L2300400 | 561 | L3211011 | 285 | L3274656 | 279 | L3400046 | 119 | L3900065 | 162 | L4400214 | 178 | L4424666 | 187 |
| L0709080 | 254 | L1508025 | 227 | L2300402 | 561 | L3211013 | 285 | L3274700 | 278 | L3400300 | 119 | L3900074 | 155 | L4400215 | 195 | L4427079 | 177 |
| L0709508 | 266 | L1508035 | 227 | L2300500 | 561 | L3211015 | 285 | L3274718 | 277 | L3400350 | 119 | L3900075 | 162 | L4400217 | 182 | L4428602 | 181 |
| L0710080 | 254 | L1508050 | 227 | L2304700 | 562 | L3211017 | 285 | L3274720 | 277 | L3400470 | 119 | L3900082 | 155 | L4400231 | 183 | L4432110 | 190 |
| L0710521 | 215 | L1510006 | 226 | L2304800 | 562 | L3211031 | 285 | L3274733 | 276 | L3401012 | 118 | L3900125 | 162 | L4400252 | 180 | L4432158 | 182 |
| L0711080 | 254 | L1510035 | 227 | L2304900 | 562 | L3211033 | 285 | L3274734 | 277 | L3402012 | 118 | L3900225 | 162 | L4400253 | 180 | L4432172 | 161 |
| L0712001 | 255 | L1510050 | 227 | L2306228 | 562 | L3211035 | 285 | L3274736 | 276 | L3402051 | 119 | L3903240 | 162 | L4400511 | 188 | L4432358 | 180 |
| L0712002 | 255 | L1510070 | 227 | L2307300 | 563 | L3211043 | 285 | L3274756 | 276 | L3402320 | 118 | L3903360 | 162 | L4400520 | 189 | L4432601 | 181 |
| L0712008 | 255 | L1510179 | 223 | L2307301 | 563 | L3211051 | 285 | L3274760 | 277 | L3403012 | 118 | L3903640 | 162 | L4400550 | 190 | L4438170 | 179 |
| L0712078 | 255 | L1512240 | 223 | L2308502 | 563 | L3211055 | 285 | L3274766 | 276 | L3403150 | 118 | L3914360 | 152 | L4400553 | 182 | L4450000 | 191 |
| L0712080 | 254 | L1512254 | 227 | L2308600 | 562 | L3211057 | 285 | L3274952 | 283 | L3404012 | 118 | L3914363 | 148 | L4400926 | 189 | L4454077 | 183 |
| L0713080 | 254 | L1512287 | 223 | L2308601 | 562 | L3225120 | 284 | L3280000 | 277 | L3405620 | 119 | L3920050 | 155 | L4400939 | 189 | L4472032 | 174 |
| L0714080 | 254 | L1513070 | 227 | L2309801 | 562 | L3227120 | 280 | L3280015 | 282 | L3410000 | 119 | L3920074 | 155 | L4400943 | 189 | L4474062 | 185 |
| L0714272 | 266 | L1523036 | 226 | L2310302 | 562 | L3230120 | 286 | L3280018 | 279 | L3415050 | 119 | L3984360 | 152 | L4401006 | 194 | L4474063 | 194 |
| L0715080 | 254 | L1534041 | 226 | L2311100 | 563 | L3230150 | 286 | L3280020 | 282 | L3485000 | 119 | L4000000 | 162 | L4401041 | 176 | L4474165 | 186 |
| L0715255 | 265 | L1567268 | 226 | L2312400 | 563 | L3230170 | 286 | L3280030 | 282 | L3600000 | 597 | L4100100 | 153 | L4401193 | 178 | L4474166 | 186 |
| L0715521 | 215 | L1568025 | 226 | L2315000 | 561 | L3230200 | 286 | L3280032 | 282 | L3600100 | 160 | L4100101 | 153 | L4401198 | 189 | L4474180 | 185 |
| L0716045 | 193 | L1568060 | 226 | L3225203 | 563 | L3230220 | 286 | L3280033 | 281 | L3604606 | 597 | L4100102 | 155 | L4401557 | 179 | L4474182 | 185 |
| L0716078 | 255 | L1568125 | 226 | L2395057 | 381 | L3230250 | 286 | L3280035 | 281 | L3674004 | 158 | L4100103 | 148 | L4401804 | 183 | L4474239 | 179 |
| L0716080 | 254 | L1568156 | 226 | L2503017 | 303 | L3230280 | 286 | L3280040 | 286 | L3674530 | 158 | L4101100 | 153 | L4402036 | 176 | L4474262 | 184 |
| L0717080 | 254 | L1568160 | 226 | L2535135 | 303 | L3230290 | 286 | L3280052 | 281 | L3674532 | 158 | L4101101 | 153 | L4402358 | 188 | L4474263 | 180 |
| L0718078 | 255 | L1568225 | 226 | L2680000 | 123 | L3230320 | 286 | L3280055 | 278 | L3674533 | 158 | L4101102 | 155 | L4402768 | 179 | L4474264 | 180 |
| L0718080 | 254 | L1568256 | 226 | L2680118 | 123 | L3230350 | 286 | L3280059 | 281 | L3674550 | 158 | L4101103 | 148 | L4402769 | 179 | L4474360 | 185 |
| L0719015 | 266 | L1568260 | 226 | L2780000 | 123 | L3230360 | 286 | L3280060 | 282 | L3674552 | 158 | L4101230 | 154 | L4403007 | 184 | L4474601 | 181 |
| L0719080 | 254 | L1580016 | 227 | L2780118 | 123 | L3230380 | 286 | L3280085 | 285 | L3674553 | 150 | L4101233 | 149 | L4403038 | 175 | L4474767 | 185 |
| L0720080 | 254 | L1580025 | 227 | L2880000 | 123 | L3230400 | 286 | L3280120 | 286 | L3674560 | 158 | L4101310 | 154 | L4403175 | 190 | L4474910 | 185 |
| L0720521 | 215 | L1580035 | 227 | L2880118 | 123 | L3230450 | 286 | L3280121 | 284 | L3674563 | 158 | L4101313 | 149 | L4403358 | 188 | L4474926 | 189 |
| L0721001 | 255 | L1580050 | 227 | L2880120 | 123 | L3230470 | 286 | L3280150 | 286 | L3674580 | 158 | L4101360 | 154 | L4403528 | 188 | L4474951 | 190 |
| L0721002 | 255 | L1580070 | 227 | L2900081 | 121 | L3230480 | 286 | L3280155 | 282 | L3674582 | 158 | L4101363 | 149 | L4404016 | 176 | L4475062 | 185 |
| L0721080 | 254 | L1582016 | 227 | L2910050 | 121 | L3230500 | 286 | L3280170 | 286 | L3674583 | 150 | L4101530 | 154 | L4404038 | 175 | L4475085 | 161 |
| L0722080 | 254 | L1582025 | 227 | L2960055 | 121 | L3230520 | 286 | L3280180 | 281 | L3674610 | 158 | L4101533 | 149 | L4404299 | 166 | L4475180 | 185 |
| L0722405 | 267 | L1582035 | 227 | L2960084 | 121 | L3230580 | 286 | L3280184 | 284 | L3674612 | 158 | L4101610 | 154 | L4404609 | 181 | L4475182 | 185 |
| L0723080 | 254 | L1582050 | 227 | L2960177 | 121 | L3230600 | 286 | L3280185 | 284 | L3674613 | 150 | L4101613 | 149 | L4404625 | 596 | L4475262 | 184 |
| L0725007 | 266 | L1582070 | 227 | L3000008 | 122 | L3230650 | 286 | L3280190 | 284 | L3679530 | 158 | L4114360 | 152 | L4405028 | 175 | L4475360 | 185 |
| L0725521 | 215 | L1800046 | 110 | L3000100 | 122 | L3232520 | 279 | L3280200 | 286 | L3679550 | 158 | L4114363 | 148 | L4405070 | 181 | L4475767 | 185 |
| L0727010 | 266 | L1800300 | 110 | L3000150 | 122 | L3232656 | 279 | L3280240 | 284 | L3679580 | 158 | L4120360 | 155 | L4406003 | 164 | L4475910 | 185 |
| L0728014 | 266 | L1800390 | 110 | L3013150 | 122 | L3235500 | 311 | L3280250 | 286 | L3679610 | 158 | L4174360 | 152 | L4406006 | 164 | L4478032 | 161 |
| L0730521 | 215 | L1802003 | 110 | L3100018 | 122 | L3238180 | 286 | L3280300 | 286 | L3680004 | 158 | L4174363 | 148 | L4406012 | 163 | L4480003 | 164 |
| L0731011 | 265 | L1804012 | 110 | L3100054 | 309 | L3240501 | 311 | L3280350 | 286 | L3680530 | 158 | L4182360 | 152 | L4406023 | 194 | L4482169 | 191 |
| L0733047 | 266 | L1806050 | 110 | L3100119 | 306 | L3252660 | 276 | L3280380 | 286 | L3680532 | 158 | L4184360 | 152 | L4406038 | 175 | L4491010 | 194 |
| L0740016 | 266 | L1808000 | 110 | L3100158 | 306 | L3270502 | 311 | L3280400 | 286 | L3680533 | 158 | L4214360 | 152 | L4406070 | 181 | L4491025 | 186 |
| L0740018 | 266 | L1900072 | 109 | L3100160 | 307 | L3274015 | 282 | L3280401 | 282 | L3680550 | 158 | L4214363 | 148 | L4406299 | 166 | L4491054 | 187 |
| L0740521 | 215 | L1900240 | 109 | L3100250 | 308 | L3274018 | 279 | L3280450 | 286 | L3680552 | 158 | L4274360 | 152 | L4406536 | 166 | L4501080 | 303 |
| L0750521 | 215 | L1900500 | 109 | L3100331 | 308 | L3274020 | 282 | L3280500 | 286 | L3680553 | 150 | L4274363 | 148 | L4407020 | 177 | L4503074 | 300 |
| L0750522 | 215 | L1920500 | 109 | L3100335 | 308 | L3274030 | 282 | L3280520 | 279 | L3680560 | 158 | L4282360 | 152 | L4408020 | 177 | L4505030 | 303 |
| L0780022 | 255 | L1944035 | 109 | L3100353 | 306 | L3274032 | 282 | L3280521 | 280 | L3680562 | 158 | L4300000 | 597 | L4408060 | 178 | L4512080 | 300 |
| L0791101 | 264 | L1977002 | 167 | L3101119 | 306 | L3274033 | 281 | L3280522 | 280 | L3680563 | 158 | L4300001 | 163 | L4409028 | 194 | L4515080 | 300 |
| L0808012 | 193 | L1990070 | 109 | L3102125 | 305 | L3274035 | 281 | L3280523 | 280 | L3680580 | 158 | L4304299 | 166 | L4409070 | 181 | L4515174 | 301 |
| L0808024 | 193 | L1990450S | 109 | L3102188 | 308 | L3274052</ | | | | | | | | | | | |

| | | | | | | | | | | | | | | | | | |
|----------|-----|----------|-----|----------|-----|----------|-----|----------|-----|-----------|-----|------------|-----|----------|-----|----------|-----|
| L4600045 | 271 | L5304080 | 298 | L5312230 | 291 | L5316375 | 323 | L5322633 | 291 | L5385427 | 292 | L5874612 | 157 | L7400360 | 144 | L8106055 | 484 |
| L4600057 | 270 | L5305080 | 299 | L5312300 | 291 | L5316633 | 291 | L5323000 | 291 | L5385459 | 292 | L5874613 | 150 | L7400361 | 144 | L8106060 | 484 |
| L4600071 | 270 | L5305100 | 299 | L5312302 | 291 | L5317000 | 291 | L5323045 | 291 | L5385488 | 292 | L5880003 | 155 | L7401010 | 145 | L8106070 | 484 |
| L4600146 | 271 | L5307074 | 298 | L5312304 | 291 | L5317045 | 291 | L5323179 | 291 | L5385519 | 292 | L5880004 | 157 | L7401100 | 145 | L8106080 | 484 |
| L4600230 | 270 | L5307079 | 298 | L5312308 | 291 | L5317062 | 295 | L5323205 | 291 | L5412004 | 38 | L5880530 | 157 | L7401230 | 145 | L8106085 | 484 |
| L4600650 | 272 | L5307080 | 298 | L5312314 | 291 | L5317131 | 294 | L5323230 | 291 | L5416033 | 325 | L5880533 | 150 | L7401310 | 144 | L8110025 | 481 |
| L4600653 | 273 | L5308005 | 291 | L5312330 | 291 | L5317179 | 291 | L5323300 | 291 | L5416079 | 325 | L5880550 | 157 | L7401360 | 144 | L8110030 | 481 |
| L4600820 | 271 | L5308045 | 291 | L5312332 | 291 | L5317205 | 291 | L5323308 | 291 | L5416080 | 325 | L5880553 | 150 | L7401510 | 145 | L8110035 | 481 |
| L4601308 | 273 | L5308074 | 298 | L5312366 | 293 | L5317230 | 291 | L5323330 | 291 | L5416375 | 325 | L5880560 | 157 | L7401530 | 145 | L8110040 | 481 |
| L4602050 | 273 | L5308079 | 298 | L5312633 | 291 | L5317300 | 291 | L5323332 | 291 | L5416607 | 325 | L5880563 | 150 | L7401610 | 145 | L8110045 | 481 |
| L4602240 | 272 | L5308080 | 298 | L5313000 | 291 | L5317302 | 291 | L5323633 | 291 | L5416637 | 325 | L5880580 | 157 | L7474360 | 144 | L8110050 | 481 |
| L4603493 | 273 | L5308179 | 291 | L5313045 | 291 | L5317304 | 291 | L5324000 | 291 | L5416677 | 325 | L5880583 | 150 | L7474530 | 146 | L8110055 | 481 |
| L4604030 | 311 | L5308205 | 291 | L5313062 | 295 | L5317305 | 291 | L5324045 | 291 | L5416687 | 325 | L5880610 | 157 | L7474550 | 146 | L8110060 | 481 |
| L4604618 | 597 | L5308230 | 291 | L5313131 | 294 | L5317308 | 291 | L5324179 | 291 | L5419004 | 38 | L5880613 | 150 | L7474610 | 146 | L8110125 | 481 |
| L4605060 | 270 | L5308300 | 291 | L5313179 | 291 | L5317330 | 291 | L5324205 | 291 | L5424607 | 325 | L5880630 | 159 | L7480530 | 146 | L8110130 | 481 |
| L4606070 | 270 | L5308302 | 291 | L5313205 | 291 | L5317332 | 291 | L5324230 | 291 | L5427375 | 325 | L5974531C | 159 | L7480550 | 146 | L8110135 | 481 |
| L4609000 | 310 | L5308308 | 291 | L5313230 | 291 | L5317366 | 293 | L5324300 | 291 | L5433375 | 325 | L5974532 | 159 | L7480610 | 146 | L8110140 | 481 |
| L4609001 | 310 | L5308314 | 291 | L5313300 | 291 | L5317633 | 291 | L5324308 | 291 | L5433510 | 324 | L5974533 | 149 | L7632530 | 146 | L8110150 | 488 |
| L4609002 | 310 | L5308330 | 291 | L5313302 | 291 | L5318000 | 291 | L5324330 | 291 | L5433606 | 324 | L5974550 | 159 | L7632550 | 146 | L8110625 | 480 |
| L4609311 | 310 | L5308332 | 291 | L5313304 | 291 | L5318011 | 328 | L5324332 | 291 | L5433607 | 325 | L5974551C | 159 | L7632560 | 146 | L8110630 | 480 |
| L4618002 | 272 | L5308633 | 291 | L5313305 | 291 | L5318045 | 291 | L5324633 | 291 | L5434606 | 324 | L5974552 | 159 | L7632580 | 146 | L8110635 | 480 |
| L4618003 | 272 | L5309000 | 291 | L5313308 | 291 | L5318062 | 295 | L5325332 | 291 | L5435606 | 324 | L5974553 | 149 | L7674003 | 146 | L8110640 | 480 |
| L4620003 | 304 | L5309045 | 291 | L5313314 | 291 | L5318131 | 294 | L5326332 | 291 | L5436606 | 324 | L5974560 | 159 | L7674530 | 146 | L8110645 | 480 |
| L4622003 | 304 | L5309074 | 298 | L5313330 | 291 | L5318179 | 291 | L5327332 | 291 | L5437033 | 324 | L5974561C | 159 | L7674550 | 146 | L8110650 | 480 |
| L4622015 | 304 | L5309080 | 298 | L5313332 | 291 | L5318205 | 291 | L5327375 | 323 | L5437079 | 324 | L5974562 | 159 | L7674660 | 146 | L8110655 | 480 |
| L4642004 | 304 | L5309179 | 291 | L5313366 | 293 | L5318230 | 291 | L5327484 | 295 | L5437080 | 324 | L5974563 | 149 | L7674580 | 146 | L8110660 | 480 |
| L4660727 | 270 | L5309205 | 291 | L5313633 | 291 | L5318300 | 291 | L5328332 | 291 | L5437375 | 324 | L5974580 | 159 | L7680003 | 146 | L8113027 | 483 |
| L4674065 | 272 | L5309230 | 291 | L5313701 | 326 | L5318302 | 291 | L5329332 | 291 | L5446510 | 324 | L5974581C | 159 | L7680530 | 146 | L8113035 | 483 |
| L4674160 | 272 | L5309300 | 291 | L5314001 | 291 | L5318304 | 291 | L5330332 | 291 | L5479375 | 325 | L5974582 | 159 | L7680550 | 146 | L8113045 | 483 |
| L4674180 | 272 | L5309302 | 291 | L5314045 | 291 | L5318305 | 291 | L5332332 | 291 | L5479510 | 324 | L5974583 | 149 | L7680560 | 146 | L8113125 | 480 |
| L4674659 | 273 | L5309308 | 291 | L5314062 | 295 | L5318308 | 291 | L5333162 | 328 | L5479607 | 325 | L5974610 | 159 | L7680580 | 146 | L8113135 | 480 |
| L4870030 | 303 | L5309314 | 291 | L5314131 | 294 | L5318330 | 291 | L5333370 | 322 | L5480375 | 325 | L5974611C | 159 | L8000100 | 145 | L8113140 | 480 |
| L4870031 | 303 | L5309330 | 291 | L5314179 | 291 | L5318332 | 291 | L5333375 | 323 | L5480510 | 324 | L5974612 | 159 | L8000360 | 144 | L8113325 | 505 |
| L4870032 | 303 | L5309332 | 291 | L5314205 | 291 | L5318366 | 293 | L5333515 | 323 | L5480607 | 325 | L5974613 | 159 | L8000361 | 144 | L8113335 | 505 |
| L5125038 | 288 | L5309366 | 293 | L5314230 | 291 | L5318633 | 291 | L5333606 | 322 | L5774530 | 156 | L5980530 | 149 | L8001010 | 145 | L8113340 | 505 |
| L5128074 | 287 | L5309633 | 291 | L5314300 | 291 | L5319000 | 291 | L5334332 | 291 | L5774532 | 156 | L5980533 | 149 | L8001100 | 145 | L8114040 | 480 |
| L5128079 | 287 | L5310000 | 291 | L5314302 | 291 | L5319045 | 291 | L5335606 | 322 | L5774550 | 156 | L5980550 | 159 | L8001230 | 145 | L8114045 | 480 |
| L5128080 | 287 | L5310045 | 291 | L5314304 | 291 | L5319062 | 295 | L5336332 | 291 | L5774552 | 156 | L5980553 | 149 | L8001310 | 144 | L8114050 | 480 |
| L5132004 | 288 | L5310062 | 295 | L5314305 | 291 | L5319131 | 294 | L5337093 | 317 | L5774560 | 156 | L5980560 | 159 | L8001360 | 144 | L8114055 | 480 |
| L5132079 | 287 | L5310074 | 298 | L5314308 | 291 | L5319179 | 291 | L5337370 | 322 | L5774580 | 156 | L5980563 | 149 | L8001510 | 145 | L8114075 | 480 |
| L5132080 | 287 | L5310079 | 298 | L5314314 | 291 | L5319205 | 291 | L5338332 | 291 | L5774610 | 156 | L5980580 | 159 | L8001530 | 145 | L8114125 | 481 |
| L5132403 | 288 | L5310080 | 298 | L5314330 | 291 | L5319230 | 291 | L5340067 | 294 | L5779530 | 156 | L5980583 | 149 | L8001610 | 145 | L8114130 | 488 |
| L5132404 | 288 | L5310131 | 294 | L5314332 | 291 | L5319300 | 291 | L5340615 | 323 | L5779550 | 156 | L5980610 | 159 | L8074360 | 144 | L8115016 | 480 |
| L5135074 | 287 | L5310179 | 291 | L5314366 | 293 | L5319305 | 291 | L5350100 | 299 | L5779560 | 156 | L5980613 | 149 | L8100018 | 484 | L8115020 | 480 |
| L5135079 | 287 | L5310205 | 291 | L5314633 | 291 | L5319308 | 291 | L5350800 | 299 | L5779580 | 156 | L6074530 | 156 | L8100022 | 484 | L8115024 | 480 |
| L5135080 | 287 | L5310230 | 291 | L5315000 | 291 | L5319330 | 291 | L5352072 | 326 | L5779610 | 156 | L6074550 | 156 | L8100025 | 484 | L8115025 | 480 |
| L5139074 | 287 | L5310284 | 479 | L5315039 | 328 | L5319332 | 291 | L5362100 | 299 | L5780012 | 159 | L6074560 | 156 | L8100028 | 484 | L8115033 | 480 |
| L5139080 | 287 | L5310300 | 291 | L5315045 | 291 | L5319633 | 291 | L5362557 | 479 | L5780013 | 159 | L6074580 | 156 | L8100030 | 484 | L8115037 | 480 |
| L5152000 | 288 | L5310302 | 291 | L5315062 | 295 | L5320001 | 291 | L5362558 | 479 | L5780530 | 156 | L6074610 | 156 | L8100032 | 484 | L8115040 | 480 |
| L5173060 | 288 | L5310308 | 291 | L5315131 | 294 | L5320045 | 291 | L5362559 | 479 | L5780550 | 156 | L6080530 | 156 | L8100035 | 484 | L8115045 | 480 |
| L5173061 | 288 | L5310314 | 291 | L5315179 | 291 | L5320062 | 295 | L5362560 | 479 | L5780560 | 156 | L6080550 | 156 | L8100038 | 484 | L8115038 | 483 |
| L5174061 | 288 | L5310330 | 291 | L5315205 | 291 | L5320131 | 294 | L5362561 | 479 | L5780580 | 156 | L6080560 | 156 | L8100040 | 484 | L8119042 | 483 |
| L5300002 | 296 | L5310332 | 291 | L5315230 | 291 | L5320179 | 291 | L5362562 | 479 | L5780610 | 156 | L6080580 | 156 | L8100045 | 484 | L8119046 | 483 |
| L5300012 | 296 | L5310366 | 293 | L5315300 | 291 | L5320205 | 291 | L5362563 | 479 | L5832530 | 157 | L6080610 | 156 | L8100050 | 484 | L8119134 | 481 |
| L5300035 | 296 | L5310633 | 291 | L5315302 | 291 | L5320230 | 291 | L5365095 | 295 | L5832533 | 150 | L6232002 | 161 | L8100055 | 484 | L8119139 | 481 |
| L5300047 | 296 | L5311000 | 291 | L5315304 | 291 | L5320300 | 291 | L5371066 | 293 | L5832550 | 157 | L6274002 | 161 | L8100154 | 488 | L8119149 | 481 |
| L5300051 | 296 | L5311045 | 291 | L5315305 | 291 | L5320305 | 291 | L5374083 | 290 | L5832553 | 150 | L6400193 | 379 | L8104010 | 488 | L8119236 | 481 |
| L5300054 | 296 | L5311062 | 295 | L5315308 | 291 | L5320308 | 291 | L5374090 | 290 | L5832560 | 157 | L6400601 | 382 | L8104012 | 488 | L8119343 | 484 |
| L5300100 | 299 | L5311131 | 294 | L5315314 | 291 | L5320330 | 291 | L5374160 | 328 | L5832563 | 150 | L6401220 | 379 | L8104014 | 488 | L8119442 | 484 |
| L5300150 | 297 | L5311179 | 291 | L5315330 | 291 | L5320332 | 291 | L5374161 | 328 | L5832580 | 157 | L6402490 | 274 | L8104016 | 488 | L8119446 | 484 |
| L5300160 | 296 | L5311205 | 291 | L5315332 | 291 | L5320633 | 291 | L5374162 | 328 | L5832583 | 150 | L6412062 | 382 | L8104602 | 488 | L8119559 | 480 |
| L5300232 | 296 | L5311228 | 290 | L5315366 | 293 | L5321000 | 291 | L5374163 | 328 | L5832610 | 157 | L6412063 | 382 | L8104603 | 488 | L8120005 | 486 |
| L5300300 | 297 | L5311230 | 291 | L5315633 | 291 | L5321045 | 291 | L5374228 | 290 | L5832613 | 150 | L6412156 | 274 | L8104604 | 488 | L8120007 | 486 |
| L5300305 | 296 | L5311300 | 291 | L5316000 | 291 | L5321179 | 291 | L5379370 | 322 | L5874003 | 155 | L6412180 | 274 | L8104605 | 488 | L8120009 | 486 |
| L5300366 | 297 | L5311302 | 291 | L5316033 | 323 | L5321205 | 291 | L5379375 | 323 | L5874004 | 157 | L6412260 | 383 | L8105070 | 484 | L8120011 | 486 |
| L5300427 | 297 | L5311308 | 291 | L5316045 | 291 | L5321230 | 291 | L5379515 | 323 | L5874530 | 157 | L6412910 | 382 | L8105075 | 484 | L8120012 | 486 |
| L5300488 | 297 | L5311314 | 291 | L5316062 | 295 | L5321300 | 291 | L5379606 | 322 | L5874531C | 157 | L6470225</ | | | | | |

| | | | | | | | | | | | | | | | | | |
|----------|-----|----------|-----|----------|-----|----------|----|----------|-----|----------|-----|-----------|-----|----------|-----|----------|-----|
| L8120316 | 488 | L8145202 | 498 | L8240131 | 504 | M0308090 | 59 | M1308004 | 59 | M2640240 | 88 | M3525070 | 82 | M3638350 | 331 | N0101212 | 419 |
| L8120320 | 487 | L8145203 | 495 | L8240132 | 505 | M0310100 | 59 | M1308014 | 66 | M2640900 | 90 | M3525075 | 86 | M3638500 | 331 | N0101462 | 411 |
| L8120404 | 487 | L8145303 | 494 | L8240133 | 504 | M0310105 | 59 | M1308040 | 58 | M2642020 | 91 | M3525355 | 329 | M3640500 | 331 | N0102015 | 391 |
| L8120412 | 486 | L8145304 | 494 | L8240135 | 504 | M0405050 | 69 | M1308045 | 66 | M2642250 | 90 | M3525400 | 329 | M3645900 | 331 | N0102050 | 461 |
| L8120413 | 486 | L8145305 | 494 | L8240308 | 504 | M0406060 | 69 | M1308810 | 59 | M2644250 | 89 | M3525600 | 329 | M3650500 | 331 | N0102060 | 461 |
| L8120414 | 485 | L8145310 | 496 | L8240739 | 505 | M0407070 | 69 | M1310004 | 59 | M2645003 | 90 | M3525700 | 329 | M3650600 | 331 | N0102212 | 419 |
| L8120420 | 486 | L8145311 | 494 | L8242304 | 489 | M0408080 | 69 | M1310016 | 66 | M2645004 | 90 | M3527040 | 86 | M3655700 | 331 | N0102251 | 418 |
| L8125510 | 482 | L8145312 | 494 | L8242307 | 490 | M0410100 | 69 | M1310022 | 59 | M2648225 | 91 | M3528600 | 329 | M3660900 | 331 | N0102411 | 413 |
| L8125511 | 482 | L8145319 | 499 | L8242308 | 490 | M0500080 | 69 | M1310060 | 66 | M2649260 | 92 | M3529550 | 329 | M3705380 | 331 | N0102415 | 459 |
| L8125514 | 482 | L8145320 | 495 | L8243003 | 510 | M0500100 | 69 | M1310130 | 58 | M2649290 | 92 | M3530057 | 82 | M3710250 | 331 | N0103028 | 461 |
| L8125515 | 482 | L8145323 | 497 | L8243004 | 511 | M0504040 | 69 | M1312023 | 66 | M2650000 | 92 | M3530065 | 79 | M3710380 | 331 | N0103050 | 461 |
| L8125518 | 483 | L8145505 | 495 | L8243005 | 495 | M0505050 | 69 | M1312070 | 66 | M2650001 | 90 | M3530100 | 86 | M3710381 | 331 | N0103110 | 414 |
| L8125530 | 483 | L8145514 | 496 | L8243013 | 495 | M0506060 | 69 | M1312812 | 59 | M2650003 | 90 | M3530120 | 83 | M3715430 | 331 | N0103258 | 408 |
| L8125532 | 483 | L8146001 | 506 | L8243014 | 496 | M0507070 | 69 | M1314025 | 66 | M2650025 | 91 | M3532000 | 330 | M3718250 | 331 | N0103408 | 408 |
| L8125533 | 483 | L8146003 | 506 | L8243117 | 496 | M0508080 | 69 | M1314056 | 66 | M2650095 | 91 | M3532001 | 330 | M3718355 | 331 | N0103412 | 407 |
| L8125540 | 483 | L8146004 | 506 | L8243118 | 497 | M0510100 | 69 | M1316032 | 66 | M2650103 | 90 | M3532002 | 330 | M3720600 | 331 | N0103629 | 457 |
| L8125560 | 483 | L8146006 | 506 | L8243119 | 496 | M0512120 | 69 | M1316080 | 66 | M2674045 | 88 | M3532003 | 330 | M3725355 | 331 | N0103711 | 456 |
| L8125570 | 481 | L8146015 | 506 | L8243120 | 497 | M0514140 | 69 | M1318032 | 66 | M2674079 | 89 | M3532004 | 330 | M3725430 | 331 | N0104250 | 407 |
| L8125580 | 482 | L8146016 | 506 | L8243121 | 498 | M0607050 | 68 | M1320038 | 66 | M2674179 | 89 | M3532005 | 330 | M3725601 | 331 | N0104311 | 419 |
| L8125581 | 482 | L8146022 | 507 | L8243122 | 497 | M0607070 | 68 | M1506000 | 573 | M2674230 | 91 | M3532006 | 330 | M3730600 | 331 | N0105024 | 456 |
| L8125582 | 482 | L8146023 | 507 | L8243125 | 499 | M0607085 | 68 | M1507000 | 573 | M2680079 | 89 | M3532007 | 330 | M3735381 | 331 | N0105026 | 422 |
| L8140000 | 503 | L8146024 | 507 | L8243350 | 494 | M0607095 | 68 | M1508000 | 573 | M2680179 | 89 | M3532009 | 330 | M3735430 | 331 | N0105074 | 423 |
| L8140004 | 505 | L8146025 | 509 | L8243968 | 511 | M0607135 | 68 | M1513058 | 573 | M2680272 | 91 | M3532011 | 330 | M3735600 | 331 | N0105082 | 456 |
| L8140010 | 502 | L8146105 | 507 | L8243983 | 511 | M0610100 | 69 | M1800020 | 66 | M2708380 | 92 | M3532012 | 330 | M3745430 | 331 | N0105182 | 456 |
| L8140012 | 505 | L8146115 | 508 | L8243991 | 510 | M0610101 | 69 | M1902000 | 76 | M2712420 | 572 | M3532013 | 330 | M3750601 | 331 | N0105250 | 407 |
| L8140020 | 502 | L8146116 | 507 | L8244001 | 501 | M0632050 | 68 | M1908000 | 76 | M2714500 | 572 | M3532095 | 83 | M4306060 | 59 | N0105462 | 411 |
| L8140025 | 503 | L8146117 | 508 | L8244040 | 512 | M0632075 | 68 | M1903000 | 76 | M3205050 | 69 | M3532125 | 83 | M4308085 | 59 | N0106012 | 459 |
| L8140027 | 502 | L8146118 | 507 | L8245017 | 497 | M0710110 | 68 | M1904000 | 76 | M3206060 | 69 | M3533072 | 326 | M4310100 | 59 | N0106115 | 460 |
| L8140028 | 502 | L8146301 | 508 | L8245310 | 496 | M0905020 | 65 | M1904908 | 76 | M3207070 | 69 | M3533072N | 326 | N | | N0106402 | 456 |
| L8140030 | 503 | L8146302 | 508 | L8245311 | 494 | M1002000 | 38 | M1906000 | 76 | M3208080 | 69 | M3535365 | 329 | N0010027 | 514 | N0106799 | 457 |
| L8140082 | 505 | L8146303 | 508 | L8245312 | 494 | M1002002 | 76 | M1908000 | 76 | M3210100 | 69 | M3536057 | 79 | N0028040 | 514 | N0106910 | 463 |
| L8140127 | 503 | L8146304 | 508 | L8245320 | 495 | M1003000 | 38 | M2006582 | 67 | M3500058 | 82 | M3537035 | 81 | N0074030 | 514 | N0107074 | 423 |
| L8140128 | 503 | L8146305 | 488 | L8245514 | 496 | M1003002 | 76 | M2008582 | 67 | M3500070 | 82 | M3537076 | 79 | N0074043 | 514 | N0107079 | 456 |
| L8140129 | 503 | L8146306 | 509 | L8246001 | 506 | M1004000 | 38 | M2010582 | 67 | M3500102 | 83 | M3538035 | 82 | N0079305 | 514 | N0107081 | 456 |
| L8140130 | 504 | L8147013 | 491 | L8246004 | 506 | M1004002 | 76 | M2012042 | 67 | M3500113 | 66 | M3538550 | 329 | N0100000 | 598 | N0107539 | 456 |
| L8140131 | 504 | L8147301 | 488 | L8246006 | 506 | M1005000 | 38 | M2013087 | 67 | M3500115 | 83 | M3540040 | 79 | N0100016 | 446 | N0108004 | 461 |
| L8140132 | 505 | L8147302 | 489 | L8246015 | 506 | M1005002 | 76 | M2014055 | 67 | M3500199 | 82 | M3540070 | 80 | N0100020 | 446 | N0108030 | 422 |
| L8140133 | 504 | L8147303 | 489 | L8246022 | 507 | M1006000 | 76 | M2105020 | 65 | M3500210 | 83 | M3542600 | 329 | N0100025 | 446 | N0108104 | 461 |
| L8140135 | 504 | L8147305 | 489 | L8246023 | 507 | M1006002 | 38 | M2106031 | 65 | M3500218 | 87 | M3542700 | 329 | N0100027 | 457 | N0108494 | 460 |
| L8140136 | 504 | L8147306 | 490 | L8246024 | 507 | M1006031 | 76 | M2108040 | 65 | M3500365 | 331 | M3542900 | 329 | N0100028 | 461 | N0108784 | 461 |
| L8140308 | 504 | L8147310 | 491 | L8246060 | 512 | M1008000 | 38 | M2110050 | 65 | M3501040 | 81 | M3544080 | 81 | N0100030 | 457 | N0109004 | 461 |
| L8141010 | 488 | L8147311 | 491 | L8246105 | 507 | M1010000 | 38 | M2112060 | 65 | M3501070 | 82 | M3550032 | 86 | N0100035 | 457 | N0109104 | 461 |
| L8141553 | 493 | L8147314 | 489 | L8246115 | 508 | M1012000 | 38 | M2116080 | 65 | M3501102 | 83 | M3550095 | 87 | N0100036 | 457 | N0110024 | 456 |
| L8142001 | 490 | L8147315 | 491 | L8246233 | 511 | M1014000 | 38 | M2400005 | 572 | M3501202 | 87 | M3550365 | 329 | N0100051 | 463 | N0110026 | 422 |
| L8142002 | 491 | L8147337 | 489 | L8246234 | 512 | M1016000 | 38 | M2400008 | 572 | M3501490 | 80 | M3550850 | 329 | N0100052 | 463 | N0110074 | 423 |
| L8142010 | 491 | L8148501 | 500 | L8246250 | 512 | M1018000 | 38 | M2400009 | 572 | M3501500 | 81 | M3552565 | 80 | N0100053 | 463 | N0110082 | 456 |
| L8142012 | 490 | L8148502 | 499 | L8246301 | 508 | M1020000 | 38 | M2400010 | 572 | M3501720 | 81 | M3552570 | 80 | N0100055 | 463 | N0110182 | 456 |
| L8142019 | 490 | L8148504 | 499 | L8246302 | 508 | M1022000 | 38 | M2400016 | 572 | M3502720 | 81 | M3552576 | 80 | N0100060 | 463 | N0110258 | 408 |
| L8142304 | 489 | L8148505 | 499 | L8246303 | 508 | M1024000 | 38 | M2415003 | 572 | M3504200 | 329 | M3552577 | 80 | N0100064 | 463 | N0110285 | 479 |
| L8142307 | 490 | L8148507 | 500 | L8246304 | 508 | M1026000 | 38 | M2418002 | 572 | M3505244 | 329 | M3552585 | 81 | N0100065 | 463 | N0110408 | 408 |
| L8142308 | 490 | L8148510 | 499 | L8247013 | 491 | M1028000 | 38 | M2424025 | 572 | M3506091 | 81 | M3555700 | 329 | N0100067 | 463 | N0110462 | 411 |
| L8143001 | 498 | L8148512 | 499 | L8247301 | 488 | M1030000 | 38 | M2431003 | 572 | M3508053 | 83 | M3557076 | 79 | N0100068 | 463 | N0110672 | 460 |
| L8143005 | 495 | L8148514 | 500 | L8247303 | 489 | M1105000 | 38 | M2440004 | 572 | M3508209 | 330 | M3560030 | 80 | N0100070 | 412 | N0110784 | 461 |
| L8143012 | 496 | L8149204 | 498 | L8247314 | 489 | M1106000 | 38 | M2500020 | 576 | M3508210 | 330 | M3560040 | 80 | N0100073 | 412 | N0111004 | 463 |
| L8143013 | 495 | L8149212 | 498 | L8248004 | 510 | M1108000 | 38 | M2500025 | 576 | M3508244 | 329 | M3560165 | 52 | N0100086 | 411 | N0111038 | 416 |
| L8143014 | 496 | L8149214 | 498 | L8248006 | 510 | M1110000 | 38 | M2563525 | 576 | M3508280 | 329 | M3565045 | 80 | N0100088 | 411 | N0111051 | 463 |
| L8143016 | 494 | L8150801 | 492 | L8248510 | 499 | M1112000 | 38 | M2563526 | 576 | M3508355 | 329 | M3565065 | 79 | N0100090 | 412 | N0111537 | 225 |
| L8143117 | 496 | L8150802 | 493 | L8248512 | 499 | M1114000 | 38 | M2600004 | 88 | M3508550 | 329 | M3570585 | 329 | N0100116 | 471 | N0111701 | 429 |
| L8143118 | 497 | L8150803 | 492 | L8248514 | 500 | M1116000 | 38 | M2600006 | 88 | M3508600 | 329 | M3570685 | 329 | N0100151 | 433 | N0111838 | 392 |
| L8143119 | 496 | L8150804 | 493 | L8249204 | 498 | M1119000 | 38 | M2600215 | 88 | M3509200 | 329 | M3570950 | 329 | N0100180 | 224 | N0112003 | 455 |
| L8143120 | 497 | L8150805 | 492 | L8249212 | 498 | M1120000 | 38 | M2600290 | 92 | M3509244 | 329 | M3574072N | 326 | N0100195 | 417 | N0112004 | 451 |
| L8143121 | 498 | L8150806 | 493 | L8249214 | 498 | M1124000 | 38 | M2600540 | 89 | M3510030 | 86 | M3575037 | 80 | N0100210 | 419 | N0112005 | 451 |
| L8143122 | 497 | L8150807 | 492 | L8250801 | 492 | M1204095 | 65 | M2602280 | 90 | M3510040 | 81 | M3579072N | 326 | N0100250 | 410 | N0112006 | 451 |
| L8143125 | 499 | L8150808 | 492 | L8250802 | 493 | M1205018 | 65 | M2603340 | 90 | M3511210 | 331 | M3590032 | 86 | N0100258 | 410 | N0112008 | 451 |
| L8143201 | 497 | L8150812 | 493 | L8250804 | 493 | M1206013 | 65 | M2608274 | 91 | M3511260 | 331 | M3590275 | 82 | N0100311 | 415 | N0112012 | 422 |
| L8143235 | 495 | L8150814 | 493 | L8250805 | 492 | M1206014 | 65 | M2612761 | 89 | M3511355 | 329 | M3592253 | 83 | N0100315 | 415 | N0112018 | 391 |
| L8143350 | 494 | L8240000 | 503 | L8250806 | 493 | M1206022 | 65 | M2612762 | 89 | M3512034 | 326 | M3595050 | 84 | N0100368 | 411 | N0112020 | 451 |
| L8144001 | 501 | L8240002 | 491 | L8250807 | 492 | M1208016 | 65 | M2612763 | 89 | | | | | | | | |

| | | | | | | | | | | | | | | | | | |
|----------|-----|----------|-----|-----------|-----|-----------|-----|----------|-----|----------|-----|-----------|-----|----------|-----|-----------|-----|
| N0112200 | 418 | N0115205 | 420 | N0131130 | 422 | N0174048 | 423 | N0530008 | 108 | N1030061 | 48 | N1874030 | 142 | N2134596 | 129 | N2738563 | 467 |
| N0112204 | 451 | N0115305 | 392 | N0132025 | 447 | N0174063 | 412 | N0530009 | 108 | N1100003 | 48 | N1874085 | 142 | N2140027 | 129 | N2738662 | 467 |
| N0112212 | 451 | N0116015 | 459 | N0132053 | 328 | N0174065 | 406 | N0530010 | 108 | N1100004 | 48 | N1880297 | 453 | N2140031 | 129 | N2750662 | 467 |
| N0112213 | 451 | N0116020 | 446 | N0132060 | 413 | N0174066 | 406 | N0530074 | 36 | N1100006 | 48 | N1903100 | 115 | N2140150 | 129 | N2774050 | 465 |
| N0112241 | 413 | N0116784 | 461 | N0132070 | 412 | N0174411 | 406 | N0530075 | 36 | N1100008 | 48 | N1906100 | 115 | N2140600 | 125 | N2800500 | 465 |
| N0112250 | 410 | N0118038 | 414 | N0132080 | 447 | N0175116 | 451 | N0530080 | 36 | N1100010 | 48 | N1910009 | 114 | N2150060 | 124 | N2800005 | 465 |
| N0112252 | 410 | N0118138 | 446 | N0132250 | 407 | N0179070 | 412 | N0540074 | 36 | N1200004 | 48 | N1912150 | 115 | N2150200 | 129 | N2801582 | 450 |
| N0112386 | 451 | N0118250 | 409 | N0132258 | 408 | N0179110 | 411 | N0542030 | 60 | N1200006 | 48 | N1915009 | 114 | N2160000 | 128 | N2806457 | 450 |
| N0112600 | 429 | N0118252 | 409 | N0132408 | 408 | N0180025 | 446 | N0550074 | 36 | N1200008 | 48 | N2000035 | 124 | N2170100 | 125 | N2808038 | 112 |
| N0113038 | 416 | N0118258 | 409 | N0133003 | 462 | N0180032 | 468 | N0550075 | 36 | N1200010 | 48 | N2000050 | 575 | N2201000 | 127 | N2812045 | 112 |
| N0113271 | 470 | N0118401 | 409 | N0133004 | 462 | N0180038 | 446 | N0607090 | 47 | N1200012 | 48 | N2000090 | 575 | N2201008 | 127 | N2813017 | 450 |
| N0113281 | 470 | N0118402 | 409 | N0133014 | 462 | N0180047 | 445 | N0630050 | 550 | N1306053 | 47 | N2003010 | 575 | N2202000 | 127 | N2815120 | 464 |
| N0114005 | 478 | N0118408 | 409 | N0133060 | 413 | N0180077 | 445 | N0700624 | 332 | N1308070 | 47 | N2005012 | 575 | N2202008 | 127 | N2816781 | 464 |
| N0114016 | 468 | N0118521 | 433 | N0133065 | 406 | N0180092 | 445 | N0709033 | 327 | N1310110 | 47 | N2006025 | 575 | N2203000 | 127 | N2816791 | 464 |
| N0114034 | 476 | N0118523 | 433 | N0133066 | 406 | N0182116 | 451 | N0709074 | 327 | N1313140 | 47 | N2008000 | 575 | N2203008 | 127 | N2819782 | 464 |
| N0114038 | 415 | N0119098 | 417 | N0133250 | 408 | N0184212 | 471 | N0709079 | 327 | N1350000 | 47 | N2008016 | 575 | N2204000 | 127 | N2819792 | 464 |
| N0114078 | 477 | N0119160 | 417 | N0133314 | 470 | N0195074 | 412 | N0709080 | 327 | N1360000 | 47 | N2011020 | 575 | N2204008 | 127 | N2822026 | 450 |
| N0114089 | 474 | N0119784 | 461 | N0133336 | 470 | N0195180 | 412 | N0712033 | 327 | N1370000 | 47 | N2012010 | 575 | N2205000 | 127 | N2823040 | 447 |
| N0114151 | 474 | N0120002 | 412 | N0133337 | 470 | N0195250 | 408 | N0712074 | 327 | N1380000 | 47 | N2013013 | 575 | N2205008 | 127 | N2823082 | 450 |
| N0114153 | 474 | N0120045 | 413 | N0133339 | 470 | N0195400 | 408 | N0712079 | 327 | N1403045 | 98 | N2020030 | 124 | N2206000 | 127 | N2823090 | 450 |
| N0114169 | 478 | N0120060 | 413 | N0133380 | 462 | N0200030 | 520 | N0712080 | 327 | N1404075 | 97 | N2206008 | 127 | N2206008 | 127 | N2823092 | 450 |
| N0114185 | 470 | N0120077 | 422 | N0133400 | 408 | N0200150 | 520 | N0715074 | 327 | N1435060 | 97 | N2207000 | 127 | N2207000 | 127 | N2823150 | 447 |
| N0114201 | 418 | N0120084 | 422 | N0133401 | 462 | N0200240 | 519 | N0715080 | 327 | N1445074 | 98 | N2207008 | 127 | N2207008 | 127 | N2829033 | 450 |
| N0114205 | 478 | N0120092 | 422 | N0133410 | 462 | N0200450 | 519 | N0715084 | 327 | N1445075 | 98 | N2210140 | 124 | N2208000 | 127 | N2830040 | 447 |
| N0114228 | 475 | N0120095 | 422 | N0133450 | 462 | N0200900 | 519 | N0715405 | 332 | N1455030 | 97 | N2210130 | 125 | N2208008 | 127 | N2830080 | 450 |
| N0114250 | 410 | N0120108 | 422 | N0133462 | 411 | N0206074 | 58 | N0719155 | 327 | N1455075 | 97 | N2210145 | 125 | N2209000 | 127 | N2830150 | 447 |
| N0114337 | 475 | N0120112 | 422 | N0133471 | 462 | N0206075 | 58 | N0725518 | 332 | N1460035 | 97 | N2210203 | 125 | N2212000 | 127 | N2832050 | 465 |
| N0114349 | 478 | N0120182 | 456 | N0133503 | 462 | N0206077 | 58 | N0733162 | 327 | N1465040 | 97 | N2210213 | 125 | N2213000 | 127 | N2833000 | 466 |
| N0114368 | 471 | N0120201 | 418 | N0134001 | 413 | N0206082 | 58 | N0733187 | 327 | N1465075 | 97 | N2210215 | 125 | N2214000 | 127 | N2834680 | 450 |
| N0114370 | 470 | N0120300 | 412 | N0134095 | 460 | N0206085 | 58 | N0733222 | 327 | N1468074 | 98 | N2210304 | 124 | N2215000 | 127 | N2835143 | 447 |
| N0114371 | 470 | N0121016 | 468 | N0134251 | 420 | N0208074 | 58 | N0747021 | 332 | N1468075 | 98 | N22103045 | 125 | N2216000 | 127 | N2838032 | 465 |
| N0114372 | 471 | N0122001 | 455 | N0135014 | 422 | N0208075 | 58 | N0747082 | 332 | N1475045 | 97 | N22103060 | 124 | N2217000 | 127 | N2838033 | 465 |
| N0114373 | 471 | N0122003 | 455 | N0135038 | 422 | N0208077 | 58 | N0750125 | 333 | N1515077 | 97 | N22104130 | 125 | N2218000 | 127 | N2838034 | 466 |
| N0114400 | 478 | N0122004 | 463 | N0135090 | 423 | N0208082 | 58 | N0760135 | 333 | N1515377 | 98 | N22104145 | 125 | N2219000 | 127 | N2838074 | 465 |
| N0114400 | 475 | N0122015 | 447 | N0135148 | 422 | N0208085 | 58 | N0763063 | 332 | N1555001 | 97 | N22106950 | 129 | N2220000 | 127 | N2838080 | 465 |
| N0114443 | 477 | N0122022 | 471 | N0135163 | 418 | N0210074 | 58 | N0774162 | 327 | N1574000 | 98 | N22108130 | 125 | N2221000 | 127 | N2838168 | 467 |
| N0114471 | 470 | N0122030 | 457 | N0138000C | 451 | N0210075 | 58 | N0774187 | 327 | N1575000 | 98 | N22108145 | 125 | N2222000 | 127 | N2838348 | 467 |
| N0114488 | 470 | N0122045 | 457 | N0138012 | 451 | N0210077 | 58 | N0774222 | 327 | N1575077 | 97 | N22109130 | 125 | N2223000 | 127 | N2838543 | 467 |
| N0114500 | 474 | N0122055 | 457 | N0138015 | 410 | N0210082 | 58 | N0774400 | 332 | N1660004 | 99 | N22109145 | 125 | N2301010 | 127 | N2838662 | 467 |
| N0114528 | 475 | N0122070 | 457 | N0138050 | 461 | N0210085 | 58 | N0779162 | 327 | N1700320 | 100 | N2211130 | 125 | N2302010 | 127 | N2842080 | 450 |
| N0114546 | 225 | N0122077 | 422 | N0138120 | 225 | N0212074 | 58 | N0779187 | 327 | N1725000 | 100 | N2211145 | 125 | N2303010 | 127 | N2850074 | 465 |
| N0114553 | 468 | N0122080 | 447 | N0138250 | 408 | N0212075 | 58 | N0779222 | 327 | N1725320 | 100 | N2212016 | 126 | N2304010 | 127 | N2850662 | 467 |
| N0114554 | 471 | N0122082 | 456 | N0138257 | 407 | N0212077 | 58 | N0780162 | 327 | N1725520 | 100 | N2212130 | 125 | N2305010 | 127 | N2880004 | 447 |
| N0114559 | 471 | N0122083 | 422 | N0138380 | 224 | N0212082 | 58 | N0780187 | 327 | N1730040 | 100 | N2212145 | 125 | N2306010 | 127 | N2880050 | 465 |
| N0114564 | 471 | N0122088 | 422 | N0138400 | 408 | N0212085 | 58 | N0780222 | 327 | N1760000 | 100 | N2214040 | 124 | N2307010 | 127 | N2916002 | 464 |
| N0114568 | 471 | N0122092 | 422 | N0138784 | 461 | N0218005 | 520 | N0780400 | 332 | N1774126 | 366 | N2214060 | 124 | N2308010 | 127 | N2916135 | 464 |
| N0114573 | 469 | N0122110 | 422 | N0140000 | 224 | N0218030 | 520 | N0800027 | 360 | N1774164 | 366 | N2215040 | 129 | N2309010 | 127 | N2916790 | 464 |
| N0114614 | 470 | N0122120 | 452 | N0140100 | 577 | N0222030 | 423 | N0800045 | 360 | N1775000 | 100 | N2215050 | 129 | N2312010 | 127 | N2918080 | 464 |
| N0114615 | 478 | N0122123 | 422 | N0141030 | 447 | N0222045 | 423 | N0800063 | 360 | N1780017 | 366 | N2215120 | 124 | N2313010 | 127 | N2919784 | 464 |
| N0114621 | 476 | N0122133 | 422 | N0141080 | 447 | N0224040 | 520 | N0800065 | 360 | N1780126 | 366 | N2215200 | 126 | N2314010 | 127 | N2919794 | 464 |
| N0114645 | 470 | N0123013 | 471 | N0141250 | 225 | N0229050 | 520 | N0800120 | 360 | N1780164 | 366 | N22120130 | 124 | N2315010 | 127 | N2932033C | 465 |
| N0114650 | 474 | N0123296 | 471 | N0143260 | 225 | N0230060 | 423 | N0800125 | 360 | N1785140 | 370 | N22120150 | 128 | N2316010 | 127 | N2932050 | 465 |
| N0114672 | 460 | N0124032 | 458 | N0144000 | 455 | N0232130 | 520 | N0802153 | 360 | N1800030 | 142 | N22120201 | 128 | N2317010 | 127 | N2932050C | 465 |
| N0114686 | 475 | N0124052 | 328 | N0144160 | 455 | N0232131 | 520 | N0802464 | 360 | N1810116 | 453 | N22120300 | 125 | N2318010 | 127 | N2932074C | 465 |
| N0114703 | 474 | N0124600 | 429 | N0144180 | 455 | N0271118 | 519 | N0812153 | 361 | N1812118 | 453 | N22120322 | 128 | N2319010 | 127 | N2933050 | 465 |
| N0114733 | 476 | N0124750 | 429 | N0144220 | 455 | N0300450 | 517 | N0812464 | 361 | N1812318 | 453 | N22122020 | 128 | N2320010 | 127 | N2933050C | 465 |
| N0114740 | 477 | N0125018 | 459 | N0147037 | 447 | N0306001M | 58 | N0817648 | 360 | N1815521 | 453 | N22122040 | 124 | N2321010 | 127 | N2935085 | 466 |
| N0114750 | 475 | N0125025 | 391 | N0147080 | 447 | N0306005 | 58 | N0818647 | 360 | N1816622 | 453 | N22122060 | 129 | N2322010 | 127 | N2938032 | 465 |
| N0114768 | 471 | N0125034 | 410 | N0147550 | 224 | N0306025 | 58 | N0832113 | 361 | N1818325 | 453 | N22122080 | 129 | N2323010 | 127 | N2938033 | 465 |
| N0114773 | 469 | N0125038 | 411 | N0148080 | 445 | N0306050 | 58 | N0922028 | 529 | N1819526 | 453 | N22122130 | 125 | N2501010 | 127 | N2938033C | 465 |
| N0114777 | 477 | N0125075 | 413 | N0150000 | 423 | N0306101M | 58 | N0922074 | 529 | N1820016 | 453 | N22122145 | 125 | N2502010 | 127 | N2938074C | 465 |
| N0114848 | 476 | N0125110 | 411 | N0150063 | 461 | N0308001M | 58 | N0925000 | 529 | N1820030 | 453 | N22124130 | 125 | N2503010 | 127 | N2938074C | 465 |
| N0114857 | 476 | N0126018 | 447 | N0150090 | 423 | N0308025 | 58 | N0925015 | 529 | N1820627 | 453 | N22124145 | 125 | N2504010 | 127 | N2938080 | 465 |
| N0114865 | 471 | N0126080 | 447 | N0150220 | 460 | N0308050 | 58 | N0927035 | 529 | N1825016 | 453 | N22125000 | 128 | N2505010 | 127 | N2938348 | 467 |
| N0114866 | 469 | N0128094 | 422 | N0150784 | 461 | N0308151M | 58 | N0934045 | 529 | N1825030 | 453 | N22125010 | 126 | N2506010 | 127 | N2938503 | 467 |
| N0114869 | 471 | N0128105 | 422 | N0156040 | 446 | N0310001M | 58 | N0934074 | 529 | N1825533 | 453 | N22125130 | 125 | N2507010 | 127 | N2938662 | 467 |
| N0114871 | 470 | N0128112 | 422 | N0160350 | 460 | N0310025 | 58 | N0938011 | 529 | N1825634 | 453 | N22125145 | 125 | N2508010 | 127 | N2950074 | |

| | | | | | | | | | | | | | | | | | |
|-----------|-----|----------|-----|----------|-----|-----------|-----|----------|-----|----------|-----|----------|-----|----------|-----|----------|-----|
| N3000250 | 62 | N3200198 | 60 | N3510403 | 55 | N3732050 | 49 | N4318500 | 77 | N5427030 | 125 | O0700250 | 515 | O1041503 | 359 | O2070140 | 549 |
| N3005160 | 62 | N3200210 | 60 | N3510458 | 52 | N3732075 | 49 | N4322045 | 78 | N5427045 | 125 | O0700275 | 515 | O1041507 | 359 | O2200000 | 598 |
| N3006080 | 62 | N3222110 | 573 | N3510505 | 52 | N3732100 | 49 | N4322065 | 78 | N5428030 | 125 | O0720032 | 515 | O1041531 | 362 | O2200100 | 348 |
| N3008042 | 64 | N3304079 | 39 | N3510510 | 53 | N3732150 | 49 | N4322085 | 78 | N5428045 | 125 | O0725040 | 515 | O1041532 | 362 | O2200101 | 348 |
| N3008090 | 62 | N3310000 | 573 | N3510590 | 52 | N3732200 | 49 | N4325055 | 73 | N5430045 | 125 | O0745003 | 515 | O1041540 | 359 | O2200105 | 347 |
| N3008155 | 61 | N3313000 | 573 | N3511012 | 46 | N3732300 | 49 | N4325300 | 77 | N5430046 | 125 | O0800012 | 518 | O1041542 | 359 | O2200121 | 347 |
| N3008215 | 64 | N3316000 | 573 | N3511037 | 51 | N3733050 | 49 | N4325500 | 77 | N5431030 | 125 | O0800080 | 355 | O1041543 | 359 | O2203150 | 340 |
| N3010042 | 64 | N3340050 | 44 | N3511512 | 46 | N3733075 | 49 | N4331400 | 78 | N5434030 | 124 | O0803033 | 549 | O1045610 | 364 | O2203170 | 340 |
| N3010100 | 62 | N3340100 | 44 | N3511524 | 46 | N3733100 | 49 | N4331550 | 78 | N5434045 | 124 | O0804080 | 355 | O1048370 | 359 | O2203185 | 340 |
| N3010250 | 63 | N3408082 | 67 | N3512046 | 51 | N3733150 | 49 | N4332030 | 78 | N5437030 | 125 | O0808025 | 358 | O1050075 | 363 | O2203200 | 340 |
| N3012100 | 62 | N3408090 | 67 | N3512090 | 51 | N3733200 | 49 | N4332050 | 78 | N5470100 | 125 | O0808026 | 358 | O1050076 | 363 | O2203225 | 340 |
| N3012205 | 62 | N3408102 | 67 | N3512406 | 55 | N3750010 | 49 | N4332085 | 78 | N5474030 | 124 | O0808027 | 358 | O1055120 | 365 | O2204612 | 598 |
| N3013150 | 63 | N3408122 | 67 | N3512412 | 50 | N3750016 | 49 | N4333305 | 77 | N5477030 | 124 | O0808031 | 358 | O1060075 | 363 | O2215087 | 343 |
| N3013200 | 63 | N3410065 | 67 | N3513020 | 50 | N3750020 | 49 | N4333457 | 77 | N5477045 | 124 | O0809001 | 358 | O1070060 | 365 | O2216240 | 345 |
| N3013250 | 63 | N3410101 | 67 | N3514002 | 50 | N3828430 | 133 | N4333600 | 78 | N5482060 | 124 | O0809002 | 358 | O1070160 | 365 | O2218145 | 343 |
| N3014016 | 63 | N3410120 | 67 | N3514025 | 55 | N3874246 | 78 | N4333610 | 77 | N5662247 | 573 | O0809003 | 358 | O1074060 | 365 | O2218488 | 345 |
| N3014020 | 63 | N3412075 | 67 | N3514047 | 51 | N3879246 | 78 | N4335077 | 71 | N5800066 | 389 | O0809006 | 358 | O1074160 | 365 | O2221125 | 343 |
| N3014025 | 63 | N3412120 | 67 | N3514100 | 50 | N3879250 | 78 | N4340170 | 78 | N5800131 | 388 | O0809008 | 358 | O1075034 | 364 | O2221170 | 343 |
| N3014160 | 63 | N3412130 | 67 | N3514209 | 54 | N3902120 | 60 | N4340172 | 78 | N5800211 | 388 | O0809290 | 358 | O1075052 | 364 | O2221360 | 345 |
| N3014200 | 63 | N3414150 | 67 | N3514250 | 50 | N3902150 | 60 | N4340300 | 78 | N5801004 | 350 | O0809450 | 358 | O1090220 | 362 | O2222190 | 343 |
| N3015265 | 62 | N3435012 | 76 | N3515094 | 51 | N3909001 | 56 | N4340302 | 78 | N5801034 | 350 | O0810239 | 517 | O1106040 | 42 | O2222360 | 345 |
| N3020006 | 62 | N3443014 | 76 | N3515400 | 55 | N3922160 | 54 | N4340457 | 77 | N5802034 | 350 | O0810479 | 517 | O1120000 | 351 | O2222488 | 345 |
| N3020310 | 62 | N3465018 | 76 | N3515410 | 56 | N3968004 | 56 | N4340610 | 77 | N5802045 | 350 | O0811284 | 358 | O1323114 | 353 | O2223488 | 345 |
| N3032016 | 63 | N3500210 | 50 | N3516038 | 55 | N4000350 | 519 | N4340762 | 77 | N5803035 | 350 | O0811285 | 358 | O1330125 | 353 | O2224300 | 345 |
| N3032020 | 63 | N3500260 | 50 | N3518003 | 50 | N4013000 | 574 | N4340915 | 77 | N5804034 | 350 | O0813062 | 354 | O1330400 | 353 | O2224579 | 345 |
| N3032025 | 63 | N3500321 | 50 | N3518127 | 57 | N4016060 | 574 | N4342200 | 77 | N5805000 | 350 | O0815390 | 517 | O1330600 | 353 | O2225040 | 344 |
| N3032050 | 465 | N3501082 | 57 | N3519203 | 44 | N4020060 | 574 | N4342300 | 77 | N5805096 | 74 | O0817114 | 356 | O1400181 | 315 | O2225070 | 348 |
| N3032200 | 63 | N3501083 | 57 | N3519304 | 44 | N4025000 | 527 | N4342500 | 77 | N5806034 | 350 | O0817116 | 356 | O1403000 | 315 | O2225075 | 343 |
| N3032250 | 63 | N3501084 | 57 | N3520155 | 53 | N4030000 | 527 | N4342800 | 77 | N5810004 | 350 | O0819239 | 517 | O1404080 | 317 | O2226610 | 345 |
| N3033050 | 465 | N3501087 | 57 | N3520203 | 55 | N4030070 | 519 | N4343305 | 77 | N5812025 | 351 | O0820479 | 517 | O1405000 | 312 | O2227048 | 344 |
| N3038032 | 465 | N3501523 | 53 | N3520408 | 55 | N4035000 | 527 | N4343407 | 77 | N5814005 | 350 | O0826062 | 354 | O1405100 | 318 | O2229650 | 345 |
| N3038074 | 465 | N3501524 | 53 | N3520495 | 55 | N4100140 | 574 | N4343460 | 77 | N5814007 | 350 | O0826090 | 518 | O1407000 | 315 | O2230360 | 345 |
| N3038080 | 465 | N3501526 | 57 | N3520511 | 53 | N4120075 | 574 | N4344220 | 77 | N5817004 | 350 | O0826110 | 356 | O1410205 | 321 | O2233055 | 344 |
| N3038148 | 467 | N3501527 | 57 | N3522004 | 50 | N4130120 | 519 | N4344305 | 77 | N5817007 | 350 | O0828078 | 517 | O1410911 | 321 | O2235063 | 344 |
| N3038662 | 467 | N3501528 | 57 | N3525304 | 44 | N4135075 | 574 | N4344407 | 77 | N5874250 | 388 | O0829479 | 517 | O1411000 | 313 | O2236300 | 345 |
| N3044033 | 84 | N3501540 | 53 | N3525404 | 55 | N4141639 | 574 | N4344460 | 77 | N5875066 | 389 | O0836034 | 354 | O1411002 | 313 | O2238710 | 345 |
| N3044074 | 84 | N3501542 | 53 | N3525457 | 44 | N4222042 | 70 | N4344600 | 77 | N5880210 | 388 | O0836038 | 354 | O1411040 | 316 | O2240040 | 348 |
| N3045000 | 84 | N3503000 | 46 | N3525512 | 53 | N4222043 | 70 | N4508045 | 573 | N5885066 | 389 | O0836040 | 356 | O1411042 | 316 | O2240073 | 344 |
| N3045150 | 62 | N3503010 | 46 | N3530204 | 55 | N4222048 | 71 | N4510090 | 573 | N5886250 | 388 | O0836062 | 355 | O1411100 | 318 | O2242000 | 599 |
| N3045200 | 62 | N3503011 | 46 | N3530592 | 56 | N4222049 | 71 | N4514180 | 573 | N5889066 | 389 | O0836080 | 355 | O1411102 | 318 | O2245075 | 344 |
| N3050018 | 85 | N3505027 | 51 | N3534160 | 53 | N4222050 | 72 | N5308000 | 134 | N5890150 | 388 | O0836094 | 354 | O1412000 | 320 | O2255115 | 346 |
| N3050060 | 87 | N3505058 | 51 | N3541084 | 57 | N4222054 | 70 | N5345080 | 44 | N5890152 | 388 | O0836095 | 518 | O1412074 | 314 | O2260090 | 344 |
| N3050356 | 64 | N3506033 | 51 | N3550020 | 56 | N4222056 | 70 | N5354030 | 44 | N5908100 | 75 | O0836110 | 356 | O1418210 | 320 | O2265120 | 346 |
| N3050662 | 467 | N3506034 | 51 | N3550221 | 53 | N4222061 | 70 | N5360100 | 44 | N5909075 | 75 | O0840020 | 549 | O1420054 | 313 | O2267065 | 348 |
| N3052606 | 61 | N3506070 | 53 | N3552113 | 57 | N4222062 | 70 | N5401030 | 125 | N6006200 | 75 | O0900077 | 518 | O1420254 | 313 | O2270140 | 346 |
| N3052608 | 61 | N3507033 | 51 | N3552155 | 54 | N4222066 | 72 | N5401045 | 125 | N6008240 | 75 | O0938008 | 518 | O1421000 | 313 | O2270780 | 345 |
| N3052616 | 61 | N3507036 | 51 | N3560004 | 54 | N4222073 | 72 | N5402030 | 125 | N6010270 | 75 | O0940100 | 518 | O1421002 | 313 | O2285090 | 346 |
| N3052618 | 61 | N3507040 | 51 | N3560005 | 54 | N4222076 | 70 | N5402045 | 125 | N6200500 | 369 | O100268 | 362 | O1421042 | 316 | O2290140 | 346 |
| N3056066 | 84 | N3507074 | 51 | N3560113 | 57 | N4222096 | 72 | N5403030 | 125 | N6200700 | 369 | O1000541 | 363 | O1421100 | 318 | O2299140 | 346 |
| N3057040 | 87 | N3507150 | 55 | N3561125 | 57 | N4222522 | 71 | N5403045 | 125 | N6263572 | 369 | O1000610 | 364 | O1421102 | 318 | O2400070 | 339 |
| N3059200 | 63 | N3507350 | 51 | N3564242 | 54 | N4222523 | 71 | N5404030 | 125 | N6263573 | 369 | O1000880 | 363 | O1421354 | 320 | O2400073 | 317 |
| N3059200C | 63 | N3508031 | 51 | N3566127 | 57 | N4222602 | 70 | N5404045 | 125 | N6411000 | 75 | O1000898 | 363 | O1422040 | 321 | O2400295 | 339 |
| N3060000 | 84 | N3508076 | 51 | N3570320 | 53 | N4222652 | 70 | N5405030 | 125 | N6415000 | 75 | O1003070 | 365 | O1422325 | 320 | O2405025 | 340 |
| N3074050 | 465 | N3508603 | 54 | N3575150 | 54 | N4225041 | 71 | N5405045 | 125 | N6419000 | 75 | O1003550 | 364 | O1426024 | 319 | O2405030 | 340 |
| N3075250 | 63 | N3509221 | 50 | N3575205 | 56 | N4225042 | 70 | N5407030 | 125 | N6423000 | 75 | O1005120 | 365 | O1426025 | 319 | O2405040 | 340 |
| N3080050 | 465 | N3509222 | 50 | N3575340 | 56 | N4225043 | 70 | N5407045 | 125 | N6704055 | 75 | O1007005 | 236 | O1426040 | 319 | O2405050 | 340 |
| N3080186 | 82 | N3510040 | 51 | N3586125 | 57 | N4225044 | 71 | N5408030 | 125 | N6706130 | 75 | O1007007 | 236 | O1426056 | 319 | O2420108 | 338 |
| N3100060 | 60 | N3510080 | 51 | N3590240 | 52 | N4225050 | 72 | N5408045 | 125 | N6708130 | 75 | O1007010 | 236 | O1427040 | 319 | O2422100 | 338 |
| N3100080 | 60 | N3510107 | 57 | N3600095 | 133 | N4225054 | 70 | N5409030 | 125 | N6812506 | 45 | O1007534 | 365 | O1429040 | 319 | O2422101 | 338 |
| N3100110 | 60 | N3510111 | 57 | N3600200 | 133 | N4225055 | 72 | N5409045 | 125 | N6812507 | 45 | O1010000 | 359 | O1431430 | 314 | O2422102 | 338 |
| N3100145 | 60 | N3510115 | 57 | N3700045 | 49 | N4225056 | 70 | N5410030 | 125 | N6812706 | 45 | O1010703 | 362 | O1432720 | 586 | O2422116 | 338 |
| N3100150 | 64 | N3510117 | 57 | N3700085 | 49 | N4225058 | 72 | N5410045 | 125 | N6812708 | 45 | O1011703 | 362 | O1438000 | 312 | O2425030 | 334 |
| N3100180 | 60 | N3510119 | 57 | N3700110 | 49 | N4225061 | 70 | N5411030 | 125 | | | O1012004 | 364 | O1438040 | 316 | O2425100 | 338 |
| N3100198 | 60 | N3510121 | 57 | N3700150 | 49 | N4225061C | 71 | N5411045 | 125 | O0016013 | 594 | O1013005 | 236 | O1438100 | 318 | O2430025 | 339 |
| N3100200 | 64 | N3510123 | 57 | N3700200 | 49 | N4225062 | 70 | N5412030 | 125 | O0020006 | 594 | O1013007 | 236 | O1438310 | 321 | O2430035 | 334 |
| N3100210 | 60 | N3510129 | 57 | N3700300 | 49 | N4225063 | 72 | N5412045 | 125 | O0028100 | 357 | O1013010 | 236 | O1450000 | 312 | O2430106 | 338 |
| N3100215 | 64 | N3510131 | 57 | N3708962 | 48 | N4225066 | 72 | N5413030 | 125 | O0040080 | 594 | O1015000 | 359 | O1457040 | 319 | O2430600 | 339 |
| N3101150 | 60 | N3510133 | 57 | N3710075 | 49 | N4225073 | 72 | N5415030 | 125 | O0050130 | 357 | O1024022 | 364 | O1474481 | 314 | O2432015 | 338 |
| N3112300 | | | | | | | | | | | | | | | | | |

| | | | | | | | | | | | | | | | | | | |
|----------|-----|----------|----------|----------|----------|-----------|----------|----------|----------|----------|----------|----------|----------|----------|----------|-----------|----------|-----|
| O2714185 | 334 | O4020048 | 349 | P0203256 | 449 | P0395089 | 439 | P1125002 | 142 | P1644050 | 425 | R1628180 | 522 | S0825465 | 73 | S2444073 | 87 | |
| O2714200 | 334 | O4020049 | 349 | P0203258 | 449 | P0395095 | 438 | P1125003 | 142 | P1680062 | 299 | R1635080 | 527 | S0825610 | 73 | S2501651 | 537 | |
| O2714215 | 334 | O4020057 | 349 | P0203260 | 449 | P0395101 | 438 | P1126070 | 142 | P1801100 | 135 | R1635160 | 522 | S0831008 | 73 | S2504008 | 537 | |
| O2714230 | 334 | O4020068 | 349 | P0206620 | 432 | P0532034 | 139 | P1126074 | 142 | P1801101 | 135 | R1635180 | 522 | S0928003 | 543 | S2655130 | 545 | |
| O2714245 | 334 | O4020106 | 349 | P0208035 | 430 | P0532043 | 139 | P1126077 | 142 | P1801102 | 135 | R1679150 | 522 | S0928004 | 543 | S2755200 | 545 | |
| O2800170 | 340 | O4020128 | 349 | P0210101 | 427 | P0602195 | 141 | P1180120 | 577 | P1802102 | 135 | R1680150 | 522 | S0928005 | 543 | S2755230 | 545 | |
| O2800185 | 340 | O4113023 | 349 | P0210292 | 432 | P0602215 | 141 | P1235048 | 137 | P1803070 | 135 | R2025030 | 522 | S1025003 | 543 | S2825090 | 536 | |
| O2800200 | 340 | O4113033 | 349 | P0210301 | 427 | P0602230 | 141 | P1245062 | 137 | P1804090 | 135 | R2025110 | 522 | S1100003 | 542 | S2831220 | 534 | |
| O2800225 | 340 | O4113034 | 349 | P0212000 | 432 | P0602250 | 141 | P1255073 | 137 | P1805082 | 135 | R2025125 | 522 | S1100004 | 542 | S2832160 | 533 | |
| O2800230 | 337 | O4113036 | 349 | P0212010 | 430 | P0630000 | 140 | P1265088 | 137 | P1806110 | 135 | R2028110 | 521 | S1100260 | 547 | S2832200 | 534 | |
| O2802135 | 337 | O4113044 | 349 | P0212015 | 430 | P0632170 | 140 | P1285105 | 137 | P1813540 | 135 | R2050130 | 521 | S1100300 | 547 | S2835830 | 537 | |
| O2802150 | 337 | O4113045 | 349 | P0212028 | 430 | P0632180 | 140 | P1301100 | 135 | P1815650 | 135 | R2225030 | 527 | S1103030 | 544 | S2885120 | 536 | |
| O2802155 | 337 | O4113048 | 349 | P0212031 | 430 | P0632185 | 140 | P1301101 | 135 | P1820750 | 135 | R2525080 | 527 | S1103050 | 544 | S2890120 | 536 | |
| O2802175 | 337 | O4113057 | 349 | P0212052 | 430 | P0632215 | 140 | P1301102 | 135 | P1825850 | 135 | R2600140 | 523 | S1103076 | 542 | S3000010 | 548 | |
| O2803170 | 337 | O4113068 | 349 | P0212110 | 429 | P0632230 | 140 | P1302102 | 135 | P1835048 | 137 | R2700213 | 521 | S1123003 | 542 | S3000275 | 515 | |
| O2803185 | 337 | O4200000 | 599 | P0212120 | 425 | P0635000 | 140 | P1303070 | 135 | P1835110 | 135 | R2700244 | 521 | S1130003 | 544 | S3007025 | 546 | |
| O2803200 | 337 | O4200001 | 595 | P0212126 | 427 | P0642250 | 140 | P1304090 | 135 | P1845062 | 137 | R2719220 | 521 | S1130004 | 544 | S3007060 | 546 | |
| O2803225 | 337 | O4213130 | 347 | P0212189 | 428 | P0642305 | 140 | P1305082 | 135 | P1855073 | 137 | R2731150 | 521 | S1228003 | 541 | S3007080 | 546 | |
| O2804150 | 337 | O4214145 | 347 | P0212202 | 432 | P0650000 | 140 | P1306110 | 135 | P1865088 | 137 | R2777210 | 521 | S1228004 | 541 | S3007600 | 548 | |
| O2804170 | 337 | O4214160 | 347 | P0212205 | 432 | P0703500 | 141 | P1412045 | 136 | P1885105 | 137 | R2934000 | 527 | S1400004 | 541 | S3010600 | 548 | |
| O2804185 | 337 | O4215087 | 343 | P0212605 | 429 | P0703580 | 141 | P1415058 | 136 | P2030070 | 134 | R2936000 | 527 | S1400006 | 541 | S3101003 | 539 | |
| O2804200 | 337 | O4215180 | 347 | P0212606 | 429 | P0705510 | 141 | P1418060 | 136 | P2030110 | 134 | R2940000 | 527 | S1509003 | 544 | S3101004 | 539 | |
| O2804225 | 337 | O4218145 | 343 | P0212610 | 429 | P0705630 | 141 | P1421062 | 136 | P2045170 | 134 | R2946000 | 527 | S1509004 | 544 | S3101245 | 539 | |
| O2812145 | 334 | O4219215 | 347 | P0212615 | 429 | P0722030 | 140 | P1424070 | 136 | P2060182 | 134 | R2954000 | 527 | S1509005 | 544 | S3102210 | 539 | |
| O2813155 | 334 | O4220170 | 347 | P0212756 | 429 | P0725025 | 140 | P1430090 | 136 | P2209077 | 137 | R3045000 | 528 | S1609003 | 544 | S3103003 | 538 | |
| O2813170 | 334 | O4220230 | 347 | P0215012 | 432 | P0822063 | 134 | P1510030 | 137 | P2215077 | 137 | R3050000 | 528 | S1609004 | 544 | S3103004 | 538 | |
| O2813190 | 334 | O4220250 | 347 | P0215106 | 432 | P0975015 | 138 | P1512045 | 136 | P2312045 | 136 | R3050001 | 528 | S1610240 | 120 | S3103245 | 538 | |
| O2844165 | 337 | O4221125 | 343 | P0218027 | 448 | P0975015S | 139 | P1512100 | 139 | P2315058 | 136 | R3150012 | 528 | S1611340 | 120 | S3103300 | 539 | |
| O2844180 | 337 | O4221170 | 343 | P0218510 | 431 | P0975042 | 138 | P1515043 | 137 | P2318060 | 136 | R3150014 | 528 | S1630005 | 120 | S3103330 | 538 | |
| O2844190 | 337 | O4222190 | 343 | P0218515 | 431 | P0975045 | 138 | P1515058 | 136 | P2321062 | 136 | R3150025 | 528 | S1630006 | 120 | S3103392 | 539 | |
| O2844210 | 337 | O4222488 | 345 | P0218547 | 458 | P0975048 | 138 | P1518060 | 136 | P2324070 | 136 | R3180025 | 528 | S1630007 | 120 | S3104315 | 539 | |
| O2844225 | 337 | O4223488 | 345 | P0218548 | 458 | P0975051 | 138 | P1520055 | 137 | P2330090 | 136 | R3235000 | 529 | S1630008 | 120 | S3104330 | 538 | |
| O2902120 | 335 | O4224300 | 345 | P0219001 | 459 | P0975058 | 138 | P1521062 | 136 | R | R3310043 | 528 | R3310043 | 528 | S1630009 | 120 | S3180003 | 539 |
| O2902130 | 336 | O4224579 | 345 | P0219050 | 448 | P0975059 | 138 | P1524070 | 136 | R0025130 | 524 | R3310076 | 528 | S1703139 | 540 | S3180004 | 539 | |
| O2902135 | 336 | O4225040 | 344 | P0219637 | 448 | P0975060 | 138 | P1525068 | 137 | R0025135 | 523 | R3414001 | 528 | S1705199 | 540 | S3185315 | 538 | |
| O2902140 | 335 | O4225075 | 343 | P0223018 | 448 | P0975062 | 138 | P1527027 | 139 | R0025165 | 523 | R3414002 | 528 | S1800045 | 536 | S4700075 | 117 | |
| O2902150 | 336 | O4226610 | 345 | P0224170 | 427 | P0975063 | 138 | P1530080 | 137 | R0030060 | 525 | R3445140 | 528 | S1800050 | 537 | S47210661 | 117 | |
| O2902155 | 336 | O4227048 | 344 | P0224235 | 427 | P0975063S | 139 | P1530082 | 136 | R0030100 | 351 | R3458320 | 528 | S1800070 | 537 | S47210751 | 117 | |
| O2903170 | 336 | O4227280 | 347 | P0224540 | 458 | P0975064 | 138 | P1530090 | 136 | R0030120 | 525 | R3800001 | 596 | S1825070 | 537 | S4734070 | 117 | |
| O2903185 | 336 | O4229315 | 347 | P0224543 | 458 | P0975070 | 138 | P1535100 | 136 | R0030135 | 524 | R3800072 | 386 | S1825071 | 537 | S47340721 | 116 | |
| O2903200 | 336 | O4229650 | 345 | P0224756 | 429 | P0975073 | 138 | P1535101 | 136 | R0030150 | 351 | R3800078 | 387 | S1837000 | 536 | S4900200 | 534 | |
| O2903225 | 336 | O4230360 | 345 | P0225050 | 448 | P0975080 | 138 | P1535110 | 136 | R0035130 | 524 | R3800166 | 385 | S1843001 | 536 | S6153200 | 530 | |
| O2904170 | 336 | O4233055 | 344 | P0236701 | 427 | P0975080S | 139 | P1600035 | 428 | R0074120 | 525 | R3800274 | 386 | S1880150 | 537 | S6153201 | 530 | |
| O2904185 | 336 | O4235063 | 344 | P0242115 | 447 | P0975082 | 138 | P1600055 | 428 | R0074121 | 525 | R3800400 | 385 | S1900000 | 545 | S6153230 | 530 | |
| O2904200 | 336 | O4236300 | 345 | P0245720 | 431 | P0975088 | 138 | P1600062 | 299 | R0075120 | 525 | R3802068 | 386 | S1900027 | 545 | S6153260 | 530 | |
| O2904225 | 336 | O4238710 | 345 | P0246035 | 449 | P0975091 | 138 | P1600110 | 428 | R0075121 | 525 | R3802166 | 384 | S1900048 | 545 | S6231200 | 531 | |
| O2920104 | 340 | O4240073 | 344 | P0250035 | 431 | P0975100 | 138 | P1600750 | 428 | R0082120 | 525 | R3803381 | 384 | S1902027 | 545 | S6231201 | 531 | |
| O2944165 | 336 | O4245075 | 344 | P0250055 | 431 | P0975100S | 139 | P1605050 | 428 | R0082121 | 525 | R3804038 | 385 | S1903073 | 548 | S6331230 | 531 | |
| O2944180 | 336 | O4260090 | 344 | P0250075 | 431 | P0975105 | 138 | P1606075 | 383 | R0130180 | 523 | R3804135 | 385 | S1911800 | 538 | S6331231 | 531 | |
| O2944190 | 336 | O4265120 | 346 | P0250100 | 431 | P0975110 | 138 | P1606100 | 383 | R0130210 | 523 | R3804150 | 385 | S1911804 | 538 | S6331260 | 531 | |
| O2944210 | 336 | O4270140 | 346 | P0255097 | 448 | P0975230 | 138 | P1606302 | 430 | R0330180 | 523 | R3805068 | 386 | S1922003 | 540 | T | | |
| O2944225 | 336 | O4270780 | 345 | P0280000 | 458 | P0975310 | 138 | P1610105 | 383 | R0330210 | 523 | R3806068 | 386 | S1922004 | 540 | T0106030 | 28 | |
| O2974120 | 335 | O4285090 | 346 | P0284125 | 433 | P0975310S | 139 | P1611110 | 428 | R0336240 | 523 | R3807068 | 386 | S1922623 | 548 | T0108030 | 28 | |
| O2974140 | 335 | O4290140 | 346 | P0288050 | 433 | P0975400 | 138 | P1611604 | 383 | R0430061 | 525 | R3808005 | 391 | S1925003 | 548 | T0108031 | 28 | |
| O2975120 | 335 | O4299140 | 346 | P0332001 | 435 | P0975400S | 139 | P1612011 | 424 | R0430112 | 524 | R3812070 | 392 | S1928004 | 540 | T0108040 | 28 | |
| O2975140 | 335 | P | P0340002 | 435 | P0975490 | 138 | P1612023 | 425 | R0430120 | 524 | R3820000 | 387 | S1945003 | 545 | T0110030 | 28 | | |
| O3125003 | 73 | P0000050 | 459 | P0340003 | 435 | P0975490S | 139 | P1612030 | 424 | R0430210 | 525 | R3820031 | 387 | S1955040 | 545 | T0110031 | 28 | |
| O3130003 | 73 | P0000100 | 459 | P0350005 | 435 | P0975600 | 138 | P1612035 | 425 | R0535200 | 524 | R3820066 | 389 | S2000022 | 548 | T0200230 | 100 | |
| O3222003 | 73 | P0000120 | 112 | P0350006 | 435 | P0980015 | 138 | P1612040 | 424 | R0625000 | 527 | R3825115 | 389 | S2000025 | 73 | T0200480 | 100 | |
| O3225310 | 73 | P0000130 | 112 | P0350007 | 435 | P0980051 | 138 | P1612080 | 383 | R0628000 | 527 | R3825250 | 387 | S2000060 | 546 | T0202309 | 96 | |
| O3230015 | 73 | P0000250 | 112 | P0350008 | 435 | P0980063 | 138 | P1612105 | 426 | R0810055 | 526 | R3830120 | 526 | S2000080 | 572 | T0206230 | 99 | |
| O3902135 | 336 | P0010000 | 390 | P0350009 | 435 | P0980080 | 138 | P1612106 | 426 | R0810120 | 526 | R3832440 | 384 | S2000300 | 548 | T0208022 | 99 | |
| O3903185 | 336 | P0015380 | 390 | P0350010 | 435 | P0980100 | 138 | P1612107 | 426 | R0810140 | 526 | R3860001 | 392 | S2004065 | 547 | T0208030 | 96 | |
| O3903200 | 336 | P0020033 | 565 | P0350011 | 435 | P0982015 | 138 | P1612150 | 426 | R0828180 | 527 | R3912035 | 528 | S2007055 | 546 | T0208045 | 99 | |
| O3904150 | 336 | P0023000 | 390 | P0357012 | 436 | P0982042 | 138 | P1612200 | 426 | R0832210 | 527 | S | S2025120 | 546 | T0208300 | 99 | | |
| O3904170 | 336 | P0024225 | 390 | P0357014 | 436 | P0982051 | 138 | P1612207 | 426 | R0900060 | 526 | S0025003 | 541 | S2034080 | 547 | T0232030 | 99 | |
| O3904185 | 336 | P0025000 | 390 | P0362032 | 438 | P0982063 | 138 | P1612208 | 426 | R0900140 | 60</ | | | | | | | |

| | | | | | | | | | | | | | |
|-----------|-----|----------|-----|----------|----|----------|-----|----------|-----|----------|-----|-----------|-----|
| T0910001R | 29 | T3006071 | 19 | T5110000 | 27 | T8708030 | 28 | Z0670003 | 130 | Z1808420 | 440 | Z2046503 | 238 |
| T0910180R | 29 | T3006075 | 19 | T5110075 | 27 | T8710030 | 28 | Z0670005 | 130 | Z1812000 | 443 | Z2056016 | 234 |
| T0912001R | 29 | T3008071 | 19 | T5112000 | 27 | T8710050 | 28 | Z0800015 | 560 | Z1812035 | 443 | Z2056032 | 234 |
| T0912180R | 29 | T3008075 | 19 | T5112075 | 27 | T9004000 | 33 | Z0800233 | 560 | Z1812355 | 440 | Z2070041 | 234 |
| T0914001R | 29 | T3010071 | 19 | T5112078 | 26 | T9006000 | 33 | Z0800320 | 552 | Z1812363 | 440 | Z2074012 | 258 |
| T0914180R | 29 | T3010075 | 19 | T5112209 | 25 | T9008300 | 96 | Z0800350 | 552 | Z1813150 | 393 | Z2074060 | 260 |
| T0916001R | 29 | T3012071 | 19 | T5114000 | 27 | T9402000 | 31 | Z0800351 | 552 | Z1814031 | 393 | Z2074075 | 260 |
| T0916180R | 29 | T3012075 | 19 | T5114075 | 27 | T9402030 | 31 | Z0800614 | 556 | Z1814040 | 443 | Z2074086 | 260 |
| T1003074 | 22 | T3014071 | 19 | T5114078 | 26 | T9403000 | 31 | Z0801190 | 557 | Z1824035 | 443 | Z2074095 | 258 |
| T1003075 | 22 | T3014075 | 19 | T5114212 | 25 | T9403020 | 31 | Z0801220 | 556 | Z1824040 | 443 | Z2074113 | 260 |
| T1004000 | 32 | T3305000 | 21 | T5116000 | 27 | T9502000 | 31 | Z0801320 | 553 | Z1825003 | 441 | Z2074120 | 258 |
| T1004010 | 29 | T3306000 | 21 | T5116075 | 27 | T9502030 | 31 | Z0801321 | 553 | Z1832025 | 443 | Z2074121 | 258 |
| T1004020 | 32 | T3308000 | 21 | T5116078 | 26 | T9503000 | 31 | Z0801323 | 554 | Z1845019 | 443 | Z2074160 | 260 |
| T1004074 | 22 | T3310000 | 21 | T5116212 | 25 | T9503020 | 31 | Z0801327 | 555 | Z1845038 | 443 | Z2074230 | 258 |
| T1004075 | 22 | T3312000 | 21 | T5118000 | 27 | T9602000 | 31 | Z0801328 | 555 | Z1870701 | 442 | Z2074275 | 258 |
| T1004080 | 22 | T3314000 | 21 | T5118075 | 27 | T9603000 | 31 | Z0801330 | 555 | Z2000010 | 238 | Z2075074 | 258 |
| T1005000 | 32 | T3605000 | 21 | T5120000 | 27 | T9603020 | 31 | Z0801332 | 555 | Z2000025 | 238 | Z2075086 | 258 |
| T1005074 | 22 | T3606000 | 21 | T5120075 | 27 | T9702000 | 31 | Z0801350 | 555 | Z2000237 | 253 | Z2079012 | 258 |
| T1005075 | 22 | T3608000 | 21 | T5122000 | 27 | T9703000 | 31 | Z0801370 | 555 | Z2000450 | 263 | Z2079060 | 260 |
| T1005080 | 22 | T3610000 | 21 | T5122075 | 27 | T9703020 | 31 | Z0801371 | 555 | Z2001000 | 237 | Z2079075 | 260 |
| T1006000 | 32 | T3612000 | 21 | T5124000 | 27 | | | Z0801400 | 554 | Z2001005 | 237 | Z2079086 | 260 |
| T1006010 | 29 | T3614000 | 21 | T5124075 | 27 | | | Z0801487 | 555 | Z2001013 | 236 | Z2079120 | 258 |
| T1006074 | 22 | T3705000 | 21 | T5126075 | 27 | V2537970 | 333 | Z0801701 | 554 | Z2001090 | 239 | Z2079121 | 258 |
| T1006075 | 22 | T3706000 | 21 | T5128075 | 27 | V2540360 | 333 | Z0801710 | 554 | Z2001100 | 237 | Z2081012 | 240 |
| T1006080 | 22 | T3708000 | 21 | T5208000 | 27 | V2550450 | 333 | Z0801710 | 554 | Z2001100 | 237 | Z2081012 | 240 |
| T1008000 | 32 | T3710000 | 21 | T5210000 | 27 | V2560500 | 333 | Z0803220 | 556 | Z2001105 | 237 | Z2082016 | 238 |
| T1008010 | 29 | T3712000 | 21 | T5212000 | 27 | V2565550 | 333 | Z0807013 | 564 | Z2001205 | 237 | Z2082018 | 238 |
| T1008074 | 22 | T3714000 | 21 | T5212209 | 25 | V2574000 | 595 | Z0807018 | 564 | Z2002000 | 237 | Z2082022 | 238 |
| T1008075 | 22 | T3802000 | 23 | T5214000 | 27 | V2574045 | 333 | Z0807019 | 564 | Z2002090 | 239 | Z2082024 | 238 |
| T1008080 | 22 | T3802030 | 31 | T5214212 | 25 | V2574442 | 333 | Z0807021 | 564 | Z2003015 | 238 | Z2082030 | 237 |
| T1010000 | 32 | T3802200 | 31 | T5216000 | 27 | V2578680 | 333 | Z0808420 | 558 | Z2004217 | 236 | Z2082035 | 238 |
| T1010010 | 29 | T3803000 | 23 | T5216212 | 25 | V2588044 | 333 | Z0808823 | 559 | Z2004513 | 262 | Z2082043 | 239 |
| T1010074 | 22 | T3803020 | 31 | T5218000 | 27 | | | Z0811356 | 553 | Z2004514 | 262 | Z2082103 | 237 |
| T1010075 | 22 | T3803200 | 31 | T5220000 | 27 | X0000210 | 579 | Z0814334 | 558 | Z2005092 | 238 | Z2082113 | 237 |
| T1012000 | 32 | T3804000 | 23 | T5220010 | 24 | X0000265 | 579 | Z0814604 | 558 | Z2005197 | 236 | Z2082181 | 238 |
| T1012074 | 22 | T3805000 | 23 | T5220012 | 24 | X0000350 | 579 | Z0815300 | 421 | Z2006513 | 262 | Z2086060 | 260 |
| T1012075 | 22 | T3806000 | 23 | T5220016 | 24 | X0000400 | 579 | Z0818134 | 559 | Z2006514 | 262 | Z2086086 | 260 |
| T1106000 | 33 | T3808000 | 23 | T5220012 | 25 | X0000525 | 579 | Z0818334 | 559 | Z2007013 | 236 | Z2086095 | 258 |
| T1108000 | 33 | T3810000 | 23 | T5222000 | 27 | X0000600 | 578 | Z0818420 | 558 | Z2008180 | 238 | Z2086120 | 258 |
| T1108300 | 33 | T3815000 | 23 | T5224000 | 27 | X0000700 | 578 | Z0818634 | 559 | Z2008270 | 238 | Z2086121 | 258 |
| T1110000 | 33 | T3825000 | 23 | T5226000 | 27 | X0013092 | 578 | Z0820090 | 421 | Z2010015 | 235 | Z2086160 | 260 |
| T1112000 | 33 | T3902050 | 32 | T5228000 | 27 | X0025650 | 578 | Z0824375 | 421 | Z2010025 | 235 | Z2086230 | 258 |
| T1114000 | 33 | T3903050 | 32 | T5230000 | 27 | X0040123 | 579 | Z0825200 | 566 | Z2010511 | 263 | Z2086275 | 258 |
| T1500000 | 31 | T3904040 | 32 | T5232000 | 27 | X0053592 | 579 | Z0829000 | 421 | Z2011513 | 262 | Z2095074 | 258 |
| T1618075 | 30 | T3905030 | 32 | T5708074 | 29 | | | Z0830000 | 421 | Z2011514 | 262 | Z2095079 | 258 |
| T1618080 | 30 | T4035060 | 590 | T6075000 | 33 | Z0000080 | 369 | Z0830020 | 567 | Z2012013 | 236 | Z2095086 | 258 |
| T1620062 | 30 | T4210006 | 24 | T6175000 | 33 | Z0000150 | 368 | Z0830060 | 567 | Z2012286 | 258 | Z2204003 | 380 |
| T1620074 | 30 | T4212006 | 24 | T6275000 | 33 | Z0000200 | 368 | Z0830238 | 421 | Z2013007 | 236 | Z2211230 | 379 |
| T1620075 | 30 | T4708030 | 28 | T6904000 | 32 | Z0000220 | 368 | Z0830330 | 421 | Z2016001 | 235 | Z2212115 | 380 |
| T1620080 | 30 | T4808030 | 28 | T6905000 | 32 | Z0000250 | 369 | Z0832026 | 421 | Z2016002 | 235 | Z2214126 | 380 |
| T1706000 | 32 | T4810030 | 28 | T7500000 | 31 | Z0000280 | 368 | Z0832030 | 421 | Z2016011 | 235 | Z2223026 | 380 |
| T1708000 | 32 | T4912075 | 26 | T7503000 | 31 | Z0000390 | 590 | Z0881432 | 557 | Z2016032 | 234 | Z2223028 | 380 |
| T1710000 | 32 | T4914075 | 26 | T7503020 | 31 | Z0018302 | 366 | Z0881433 | 557 | Z2016045 | 234 | Z2226125 | 380 |
| T1712000 | 32 | T4916075 | 26 | T7504000 | 31 | Z0018370 | 367 | Z0881624 | 556 | Z2016110 | 234 | Z2233118 | 381 |
| T1906000 | 33 | T4918075 | 26 | T7504013 | 31 | Z0064695 | 366 | Z0891913 | 565 | Z2020074 | 259 | Z2233206 | 381 |
| T1908000 | 33 | T4920075 | 26 | T7603000 | 31 | Z0074115 | 367 | Z1400024 | 133 | Z2020079 | 259 | Z2240045 | 449 |
| T2000025 | 595 | T4922075 | 26 | T7603020 | 31 | Z0074370 | 367 | Z1400025 | 133 | Z2020086 | 259 | Z2254057 | 449 |
| T2212000 | 33 | T4924075 | 26 | T7604000 | 31 | Z0080040 | 368 | Z1406033 | 450 | Z2021074 | 259 | Z2274118 | 381 |
| T2214000 | 33 | T5000001 | 595 | T7604013 | 31 | Z0080114 | 368 | Z1479035 | 133 | Z2021086 | 259 | Z2274206 | 381 |
| T2216000 | 33 | T5006000 | 27 | T7625022 | 31 | Z0080115 | 367 | Z1574190 | 351 | Z2022074 | 260 | Z2279118 | 381 |
| T2308010 | 33 | T5008000 | 27 | T7803000 | 31 | Z0105025 | 369 | Z1800018 | 442 | Z2022079 | 260 | Z2279140 | 380 |
| T2410000 | 33 | T5008008 | 24 | T7803020 | 31 | Z0105100 | 369 | Z1800019 | 442 | Z2022086 | 260 | Z2279206 | 381 |
| T2412075 | 33 | T5010000 | 27 | T7804000 | 31 | Z0500001 | 596 | Z1800021 | 442 | Z2023074 | 259 | Z2280118 | 381 |
| T2414075 | 33 | T5010011 | 24 | T7825022 | 31 | Z0600006 | 132 | Z1800023 | 442 | Z2024074 | 259 | Z2280206 | 381 |
| T2416000 | 33 | T5012000 | 27 | T8203000 | 31 | Z0600130 | 132 | Z1800024 | 442 | Z2024086 | 259 | Z2287093 | 449 |
| T2506000 | 32 | T5012209 | 25 | T8204000 | 31 | Z0602700 | 133 | Z1800028 | 442 | Z2025016 | 234 | Z4300165 | 86 |
| T2508000 | 32 | T5014000 | 27 | T8204013 | 31 | Z0604200 | 132 | Z1800029 | 442 | Z2025079 | 259 | | |
| T2510000 | 32 | T5014212 | 25 | T8225022 | 31 | Z0618544 | 132 | Z1800031 | 442 | Z2025086 | 259 | | |
| T2512000 | 32 | T5016000 | 27 | T8606174 | 30 | Z0620006 | 130 | Z1800032 | 442 | Z2026074 | 259 | 460215005 | 445 |
| T2604000 | 32 | T5016212 | 25 | T8606175 | 30 | Z0620007 | 130 | Z1800040 | 443 | Z2026086 | 259 | 461215234 | 445 |
| T2606000 | 32 | T5018000 | 27 | T8606180 | 30 | Z0620040 | 130 | Z1800044 | 442 | Z2027074 | 259 | 469050112 | 445 |
| T2608000 | 32 | T5020000 | 27 | T8608174 | 30 | Z0620050 | 130 | Z1800100 | 393 | Z2027086 | 259 | OT1400181 | 320 |
| T2610000 | 32 | T5022000 | 27 | T8608175 | 30 | Z0620700 | 130 | Z1800436 | 441 | Z2030074 | 259 | | |
| T2612000 | 32 | T5024000 | 27 | T8608180 | 30 | Z0621015 | 131 | Z1801000 | 393 | Z2031079 | 259 | | |
| T2705000 | 32 | T5026000 | 27 | T8610274 | 30 | Z0630008 | 131 | Z1803825 | 442 | Z2032014 | 235 | | |
| T2706000 | 32 | T5028000 | 27 | T8610275 | 30 | Z0630021 | 131 | Z1804000 | 393 | Z2032032 | 234 | | |
| T2708000 | 32 | T5030000 | 27 | T8610280 | 30 | Z0630022 | 131 | Z1808001 | 442 | Z2032110 | 234 | | |
| T2710000 | 32 | T5032000 | 27 | T8612274 | 30 | Z0630037 | 131 | Z1808011 | 441 | Z2033079 | 260 | | |
| T2912000 | 33 | T5106075 | 27 | T8612275 | 30 | Z0630038 | 131 | Z1808026 | 393 | Z2034074 | 260 | | |
| T2914000 | 33 | T5108075 | 27 | T8612280 | 30 | Z0630200 | 131 | Z1808041 | 440 | Z2034079 | 260 | | |
| | | | | | | Z0630700 | 131 | Z1808055 | 443 | Z2040403 | 236 | | |

IL FUTURO È ELETTRICO

THE FUTURE IS
ELECTRIC



**Scegli le passerelle
a movimentazione elettrica**

Choose your
servo-assisted gangway

(pag. 535)



- + ECONOMICA
INEXPENSIVE
- + PULITA
CLEAN
- + ECOLOGICA
ECOLOGICAL
- + LEGGERA
LIGHT
- + FACILE DA INSTALLARE
EASY INSTALLATION
- + ELEGANTE
STYLISH
- + MODERNA
MODERN

MEZZI DI SALVATAGGIO E DOTAZIONI DI SICUREZZA PER LE IMBARCAZIONI DA DIPORTO
Regolamento di sicurezza 5/10/1999

| MEZZI COLLETTIVI DI SALVATAGGIO | senza alcun limite | entro 50 miglia | entro 12 miglia | entro 6 miglia | entro 3 miglia | entro 1 miglio | entro 300 metri | fiumi torrenti corsi d'acqua |
|---|--------------------|-----------------|-----------------|----------------|----------------|----------------|-----------------|------------------------------|
| Zattera di salvataggio (per tutte le persone a bordo) | • | • | | | | | | |
| Zattera di salvataggio aperta (per tutte le persone a bordo) | | | • | | | | | |
| MEZZI INDIVIDUALI DI SALVATAGGIO | | | | | | | | |
| Giubbotto di salvataggio (per ogni persona a bordo) | • | • | • | • | • | • | | • |
| Salvagente anulare con cima | 1 • | 1 • | 1 • | 1 • | 1 • | 1 • | | 1 • |
| Boetta luminosa | 1 • | 1 • | 1 • | 1 • | | | | |
| DOTAZIONI | | | | | | | | |
| Bussola e tabella di deviazioni (a) | • | • | • | | | | | |
| Orologio | • | • | | | | | | |
| Barometro | • | • | | | | | | |
| Binocolo | • | • | | | | | | |
| Carte nautiche della zona di navigazione | • | • | | | | | | |
| Strumento di carteggio | • | • | | | | | | |
| Fuochi a mano a luce rossa | 4 • | 3 • | 2 • | 2 • | 2 • | | | |
| Razzi a paracadute a luce rossa | 4 • | 3 • | 2 • | 2 • | | | | |
| Boette fumogene | 3 • | 2 • | 2 • | 2 • | 1 • | | | |
| Valigetta pronto soccorso (b) | • | • | | | | | | |
| Fanali regolamentari (c) | • | • | • | • | • | | | |
| Apparecchi di segnalazione sonora | • | • | • | • | • | | | |
| STRUMENTAZIONE DI BORDO | | | | | | | | |
| Strumento di radioposizionamento (GPS) | • | • | | | | | | |
| Apparato VHF fisso | • | • | • | | | | | |
| Riflettore Radar | • | • | | | | | | |
| E.P.I.R.B. (Emergency Position Indicating Radio Beacon) | • | | | | | | | |
| ULTERIORI DOTAZIONI DI SICUREZZA PER LE UNITÀ SENZA MARCATURA CE | | | | | | | | |
| Pompa o altro attrezzo di esaurimento | • | • | • | • | • | • | | |
| Mezzi antincendio-estintori: come indicato nella tabella (all. A) annessa al D.M. 21/01/1994 n. 232 (e) | • | • | • | • | • | • | | |

Note:

- le tabelle di deviazione sono obbligatorie solo per le imbarcazioni da diporto.
- è consentito l'uso di cartografia elettronica conforme al decreto del Comandante Generale del Corpo delle Capitanerie di porto 10 luglio 2002 pubblicato nella Gazzetta Ufficiale, Serie Generale, nr. 193 del 19 agosto 2002
- secondo la tabella D allegata al Decreto del Ministero della Sanità n. 279 del 28 maggio 1988.
- nel caso di navigazione diurna fino a dodici miglia dalla costa i fanali regolamentari possono essere sostituiti con una torcia di sicurezza a luce bianca.
- per le unità aventi una lunghezza superiore a metri 12 è obbligatorio anche il fischio e la campana (la campana può essere sostituita da un dispositivo sonoro portatile).
- i natanti, indipendentemente dalla potenza del motore, devono avere a bordo solo un estintore.

Per le imbarcazioni, il numero degli estintori e la capacità estinguente sono stabiliti alla lett. B della tabella 1 annessa al citato D.M. 146/2008.

Allegato a - estintori di cui all'articolo 21 lettera p

A. IMBARCAZIONI E NAVI DA DIPORTO ABILITATE A NAVIGAZIONE "ENTRO 50 MIGLIA DALLA COSTA" E "SENZA ALCUN LIMITE"

| Potenza totale installata P (kW) | Potenza Hp | Numero e capacità estinguente degli estintori | | |
|----------------------------------|------------|---|------------------------------------|--|
| | | In plancia o posto guida | In prossimità dell'apparato motore | In ciascuno degli altri locali o gruppi di locali tra loro adiacenti |
| P < 18,4 | 25 | 1 da 13 B | - | |
| 18,4 < P < 74 | 25 < 100 | | 1 da 21 B | |
| 74 < P < 147 | 100 < 200 | | 2 da 13 B | |
| 147 < P < 294 | 200 < 500 | | 1 da 21 B e 1 da 13 B | |
| 294 < P < 368 | oltre 500 | | 1 da 34 B e 1 da 21 B | |
| P > 368 | | | 2 da 34 B | |

B. IMBARCAZIONI ABILITATE A NAVIGAZIONE "ENTRO 6 MIGLIA DALLA COSTA" E "NATANTI SENZA MARCATURA CE ABILITATE A NAVIGAZIONE ENTRO 12 MIGLIA DALLA COSTA". NECESSITANO DI N. 1 ESTINTORE COME DA TABELLA QUI SOTTO RIPORTATA.

| Potenza totale installata P (kW) | Potenza Hp | Capacità estinguente portatile |
|----------------------------------|------------|--------------------------------|
| P < 18,4 | 25 | 13 B |
| 18,4 < P < 147 | 25 < 200 | 21 B |
| P > 147 | oltre 200 | 34 B |

- Note:**
- nelle tabelle precedenti il numero che precede la lettera "b" indica la capacità estinguente dell'estintore in accordo alle unificazioni internazionali. maggiore e' il numero, maggiore e' la capacità estinguente; la capacità indicata nelle tabelle e' la minima richiesta. la lettera "b" indica invece la designazione della classe di fuoco che l'estintore e' idoneo a spegnere.
 - sulle unità da diporto possono essere sistemati anche estintori omologati per le classi di fuoco "a" o "c" purché omologati anche per la classe di fuoco "b".
 - la verifica periodica degli estintori senza manometro per la nautica da diporto non e' necessaria. il controllo consiste nell'accertamento del buono stato di conservazione.

LEGENDA | ICONS

PREZZO UNITARIO IVA ESCLUSA
prezzo conoscitivo per consentire al negoziante la vendita al dettaglio

COD. ARTICOLO

CONFEZIONE DI VENDITA

ARTICOLO PRODOTTO O PROGETTATO DA TREM

| Articolo - Item | €/pc. | €/Box |
|-----------------|-------|-------|
| C 25 05 015 | 0,40 | 20,00 |
| C 25 06 015 | 0,80 | 40,00 |
| C 25 08 015 | 1,20 | 60,00 |

50 made by TREM

PREZZO DI VENDITA TREM IVA ESCLUSA



BOBINE DA REELS OF



N. PEZZI IN SACCHETTO N. OF PCS. IN A BAG



N. PEZZI IN SCATOLA N. OF PCS. IN A BOX



N. PEZZI IN BLISTER N. OF PCS. IN A BLISTER



PESO DELLA CONFEZIONE PACKING WEIGHT



DIMENSIONI SIZE



CARICO DI ROTTURA BREAKING LOAD



ARTICOLO PRODOTTO O PROGETTATO DA TREM ITEM MADE OR DESIGNED BY TREM



NOVITÀ 2020 NEW ITEM 2020



A NORMA CE CE APPROVED



GALLEGGIABILITÀ BUOYANCY RATE

ORDINI

Si invita la Gentile Clientela (per evitare malintesi) a conferire ordini scritti specificando:

Codice Cliente — Codice Articolo — Descrizione Articolo.

L'importo minimo per ordine è di € 150,00 netti. Ordini di importo inferiore non vengono evasi.

PAGAMENTI

La prima fornitura: anticipato o contrassegno con addebito. Forniture successive verranno evase alle condizioni concordate (purché vengano forniti elementi di informazione atti a garantire la solvibilità). Le eventuali R.B. respinte annulleranno eventuali ordini in corso. Trascorso il termine stabilito per il pagamento, decorreranno gli interessi commerciali.

PREZZI

I prezzi indicati sono consigliati al pubblico **IVA ESCLUSA**.

I prezzi indicati sono da ritenersi puramente indicativi e non contrattuali e possono differire da quelli applicati dai nostri rivenditori per molteplici ragioni.

I prezzi non sono impegnativi e possono subire variazioni fino al momento della spedizione.

DISPONIBILITÀ

Alcuni prodotti e/o servizi presentati nel catalogo potrebbero non essere disponibili.

FOTOGRAFIE E COLORI

Le fotografie e le informazioni indicate nel presente catalogo non fanno parte dell'ambito contrattuale e non potranno in nessun caso essere considerate per eventuali reclami.

I colori riprodotti nelle fotografie sono da ritenersi puramente indicativi.

La pubblicazione e l'utilizzo del materiale fotografico di proprietà TR.EM. deve essere autorizzato dal nostro responsabile commerciale a mezzo lettera sottoscritta dallo stesso.

SALDI ORDINI

Le quantità di ordini a saldo verranno spedite **SALVO ORDINE CONTRARIO**, appena possibile, od unitamente ad un nuovo ordine ai prezzi di listino in vigore per importi non inferiori a € 150,00.

IMBALLO E ASSICURAZIONE

Addebito del 1% del fatturato per imballo e assicurazione a valore totale della merce trasportata.

SPEDIZIONI

Le merci sono vendute franco nostro magazzino di Osteria Grande (Bologna). Tutte le spedizioni sono comunque assicurate da noi contro i rischi di furto o smarrimento anche parziale. Per rendere operante tale assicurazione, la ricezione dal vettore di spedizioni con colli mancanti, o danneggiati, o aperti, deve essere fatta «con riserva». Il mezzo di trasporto può essere quello indicato dal Cliente. In mancanza di precise istruzioni in merito effettueremo la spedizione con il mezzo più conveniente. Eventuali ritardi nelle consegne non potranno giustificare richieste di rimborso di pagamenti di danni. Le spedizioni verranno inoltre effettuate nei quantitativi minimi di confezione.

CAMPIONI

Saranno sempre addebitati al prezzo del listino in vigore.

ATTENZIONE:

Le caratteristiche tecniche ed estetiche degli articoli sono indicative e possono essere variate in qualsiasi momento e non possono essere considerate per eventuali reclami.

PRICES

Those are per our latest Price List operative on the moment of the ordering. Our prices are, however, subject to alteration without notice.

Minimum order: EURO 500.

PACKAGING

Packaging is free of charge only if ordered goods do match with the packaging units shown in our catalogue. Any ordered quantity different from the minimum packaging planned for in the catalogue will cause an increase of 2% of the goods price, due to additional internal charges for handling it.

DELIVERY

Prices quoted are valid for goods sold Ex Works. Our customers must indicate the name and address of the forwarding agent they choose. If not, shipment will be made through the usual TR.EM. forwarder. However, on demand, we can supply free your town, debiting a competitive rate on your invoice.

INSURANCE

Goods will be insured by the seller warehouse, debiting the rate to the buyer. To enforce this insurance, when receiving goods through a forwarding agent where some packages are missing, damaged or open, please accept them "under reserve" only.

PAYMENT

By opening of irrevocable Letter of Credit on our Bank of Bologna.

SAMPLES

You will be charged for.

DESPATCH

The term of delivery and the quantities of the articles written on our Confirmation are not binding. In any case we will not be forced to pay a penalty in case of delayed or partial delivery. All differences will be settled by Bologna Courts.

PROPERTY RESERVE

Goods remains our property up to the complete payment of their price.

RESPONSIBILITY

TR.EM. srl will replace defective items only after they have been given back to be analysed, and only when the defect has been acknowledged as such.

The purchaser or the user is obliged to see whether each item is or is not suited to its relevant use. In no case shall the responsibility of TR.EM.srl exceed the cost of replacing the product.

REGOLAMENTO RESI MERCE

Vi informiamo che da oggi non saranno più autorizzati resi privi di modulo di autorizzazione (pag. 611):

Tutti i resi di merce per sostituzione, assistenza e riparazione, dovranno essere preventivamente autorizzati dalla TR.EM.

Il reso dovrà avvenire nel seguente modo:

FASE 1

La richiesta dovrà avvenire in forma scritta per mezzo del modulo presente a pag. 611. La parte in rosso è quella che dovrà completare il cliente, quella in verde il nostro ufficio vendite.

FASE 2

Se la vostra richiesta verrà accolta TR.EM. vi reinvierà il modulo compilato e firmato con allegato un numero di reso.

FASE 3

Tale numero dovrà essere riportato sul collo e sulla bolla.

Alla bolla dovrà essere allegato il modulo reinviatovi, approvato dall'ufficio vendite TR.EM.

LA MERCE RESA E PRIVA DI TALE NUMERO E DI MODULO VERRA' RESPINTA.

I reclami inoltrati trascorsi 8gg dalla consegna non verranno accettati. Nel caso di reso per sostituzione, verrà addebitato un importo pari al 15% del valore della merce più Euro 10,00 per spese contabili, salvo i maggiori oneri dell'eventuale ripristino che saranno esposti al costo.

REGULATORY FOR GOODS RETURN

We inform you that we will not accept any goods returned without RMA (pag. 611).

All the returning goods must to be previously authorized by TREM.

The authorization must be as:

STEP 1

The Customer have to ask by email or fax the authorization sending the RMA module page 611. The red part must to be filled from the Customer, the green part must to be filled from TREM.

STEP 2

If the request will be authorized TREM will send you back the RMA module filled and signed with the RMA number.

STEP 3

The RMA number must to be indicated on the documents and package. Please attach it also to the paper documents.

THE RETURNING GOODS WITHOUT RMA MODULE WILL BE SENT BACK TO YOU.

All the claims sent after 8 days after purchasing date will not be accepted. In case of acceptance of goods return, the corresponding sum due will be decreased by 15% as a compensation of the movement expenses, excluding then any possible additional cost due to the requirement of a new package.



TREM s.r.l. Via Friuli, 5 - 40060 Osteria Grande - Bologna - Italy

Tel. 39-051 69 50 511
e-mail: info@trem.net

Fax: 39-051 94 56 18
internet: www.trem.net

AUTORIZZAZIONE AL RESO MERCI N° / 2020

AUTORIZZATO DA:

CLIENTE:

COD. CLIENTE:

| ARTICOLO | Q.Ta | MOTIVO DEL RESO |
|----------|------|-----------------|
| | | |
| | | |
| | | |
| | | |

DDT/FATTURA N° DEL

CON LA PRESENTE SI AUTORIZZA IL RESO DELLA SUDETTA MERCE; **È INDISPENSABILE ALLEGARE COPIA DI TALE AUTORIZZAZIONE ALLA DDT**, AL FINE DELL'ACCETTAZIONE AL NS. MAGAZZINO.

SENZA LA PRESENTE AUTORIZZAZIONE IL RESO NON SARÀ ACCETTATO!

La merce dovrà ritornare completa della relativa documentazione, di tutti gli accessori e nel proprio imballaggio originale o comunque in un imballaggio di qualità equivalente.

TRASPORTO: il materiale sarà trasportato alle seguenti condizioni

- VS CURA (Porto Franco) NS CURA (Porto Assegnato con nostro corriere convenzionato) ALTRO (SPECIFICARE)

NOTE:

ATTENZIONE:

- Nel caso di reso non dovuto a ns. errore spedizione verrà addebitato un importo pari al 15% del valore della merce, più Euro 10 per spese contabili.
- La validità della presente è di 10 giorni a far data dalla presente. Decorso questo termine non sarà più accettato dal nostro magazzino (salvo diversi accordi presi).

Osteria Grande, lì:

TREM srl

Il tuo partner di
fiducia per tutte le
soluzioni di
pittura.

hempelyacht.it



INTERNATIONAL SALES TEAM

- 
Export Manager
 Mr. Matteo Belletti ☎ +39 348 0014743
- 
Orders & Payments Management
 Mrs. Sonia Scheda ☎ +39 051 6950507
- 
Orders & Shipment Management
 Mrs. Cristina Mandrioli ☎ +39 051 6950541
- 
Sales Assistant
 Mrs. Simona Pirazzini ☎ +39 051 6950554

info: export@trem.net | web: www.trem.net
 fax : +39 051 945618

SIAMO PRESENTI IN OLTRE 60 PAESI
 WE EXPORT IN MORE THAN 60 COUNTRIES

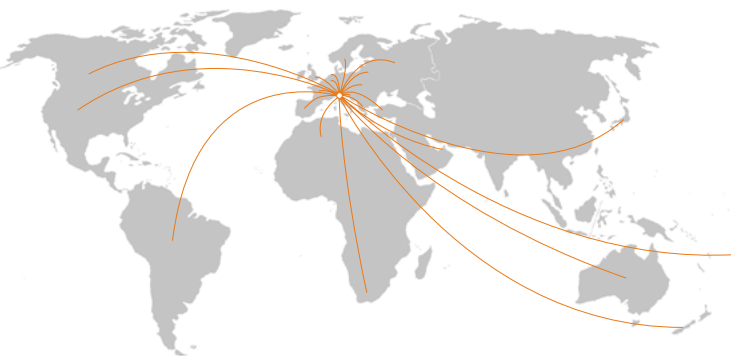

UFFICIO CONTABILITÀ E AMMINISTRAZIONE

Responsabile Amministrativo
 Luisa Ferrante
amministrazione@trem.net ☎ +39 051 6950549

UFFICIO STAMPA E MARKETING

Responsabile Ufficio Stampa e Marketing
 Yamila De Meo
marketing@trem.net ☎ +39 051 6950514

ITALIAN SALES TEAM

- Direttore commerciale Italia e ricerca prodotto**
 Davide Bertuzzi Marzaduri ☎ +39 051 6950542
- Responsabile ricevimento ordini e gestione spedizioni**
 Francesca Bombardini ☎ +39 051 6950513
- Ricevimento ordini**
 Simona Bianconi ☎ +39 051 6950540
- Gestione spedizioni e ricevimento ordini**
 Erika Biancoli ☎ +39 051 6950508

info: commerciale@trem.net | web: www.trem.net

 WhatsApp: 340 2747740



RETE DI VENDITA ITALIA

TOSCANA

Piergherardo Pacenti ☎ +39 335 6085871
pacentipiergherardo@gmail.com
 fax 0564 451713 ☎ +39 0564 451713

LIGURIA-CÔTE D'AZUR, CORSE (FRANCE)

Roberto Guaragno ☎ +39 335 1039709
roberto.guaragno@gmail.com
☎ +39 010 6456134

TRENTINO ALTO ADIGE - VENETO - FRIULI V.G.

Dario Bracco ☎ +39 335 6026711
nautica@dariobracco.it

PIEMONTE - LOMBARDIA - EMILIA (PIACENZA)

Francesco Brambilla ☎ +39 335 5456092
francesco.brambilla@fastwebnet.it
 fax 02 89072563 ☎ +39 02 89072563

EMILIA - ROMAGNA MARCHE - ABRUZZO - MOLISE

Giuseppe Ballarini ☎ +39 335 284009
gb.ballarinigiuseppe@gmail.com
 fax 0721 390150

LAZIO

Andrea Guadagnini ☎ +39 337 755872
guada.rap@alice.it
 fax 06 91014444

SARDEGNA

Ennio Fozzi ☎ +39 333 1891710
ennio-fozzi@tiscali.it
 fax 178 6011352

CAMPANIA

Dario Alfano ☎ +39 345 3077944
darioalfano@alice.it

PUGLIA - BASILICATA

Francesco Caforio ☎ +39 338 8624715
fcaforio@gmail.com

SICILIA - CALABRIA

Giuseppe Caccamo ☎ +39 348 6036031
info@giuseppecaccamo.com
 fax 095 495869 ☎ +39 095 4032150